

PART NUMBER	REV	FIRST USED
1385350-1	E	122500-1
1385350-2	D	565435-5

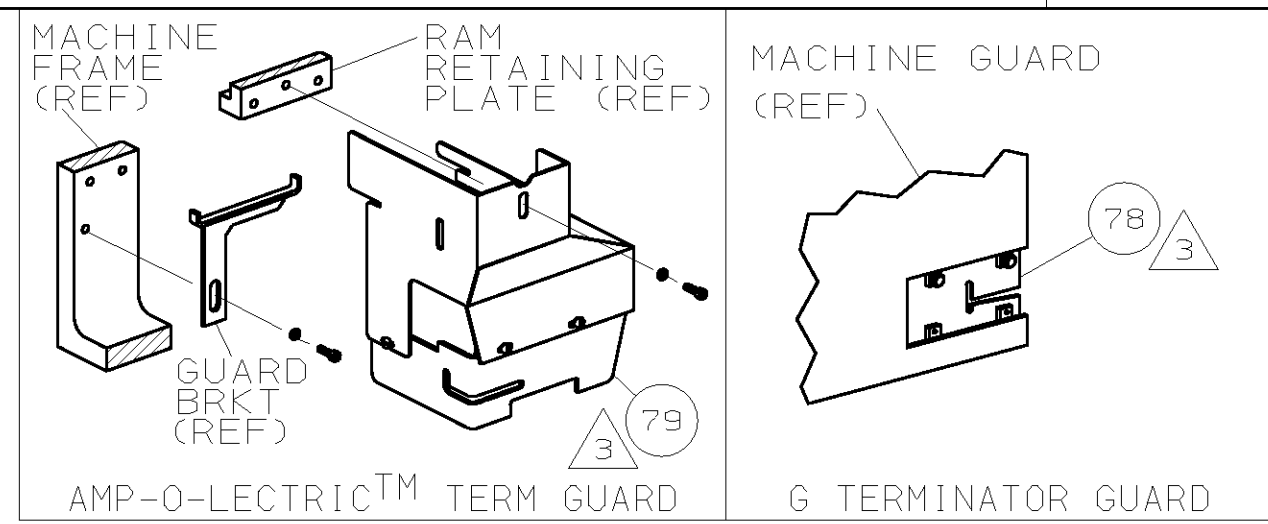

AMP PN		MFR PN		FCI TERMINAL AMP CRIMP SPECS	
1572039		AFF-1640-37			
PAD LTR	CRIMP HEIGHT		WIRE SIZE		
A	.085 ±.002 [2.16 ±0.05mm]		16		
B	.079 ±.002 [2.01 ±0.05mm]		18		
C	.076 ±.002 [1.93 ±0.05mm]		20		
D	NOT		USED		
CRIMP	SIZE	TYPE	RANGE		
WIRE	.110 [2.79mm]	F	20-16		
INSUL	.155 [3.94mm]	F	-		
WIRE STRIP LENGTH	TERM APPL SPEC	FEED	APPL INSTRUCTION	SET UP GAGE	LAYOUT
.207-.224	NONE	1.306	408-8039	458638-1	L2603

QTY	REV	U/M	DWG SIZE	PART NO	DESCRIPTION	ITEM NO
-1				LEADMAKER & BENCH MODEL G	AIR FEED	
-2				BENCH MODEL K	AIR FEED	
1	1			B	1-460277-9	AIR FEED ASSY (2 INCH)
1				C	692655-5	AIR FEED VALVE ASSY
REF				A	24042-2	VALVE, SHUT OFF
REF				C	692655-6	AIR FEED VALVE ASSY
1				B	1-460277-5	AIR FEED ASSY (2 INCH)
2	2			A	3-21000-8	SCR,SHC (10-32x2.00)AIR ASSY
-	1			A	980285-2	ELBOW, SWIVEL 1/8 NPT - 1/4 T
-	1			A	23238-1	QUICK DISCONNECT
-	12.00	IN		A	27319-4	TUBING, POLY-FLO Ø.25
1	1			C	454220-1	CAP, RAM
1	1			D	453736-1	HOUSING
1	1			B	460680-1	FEED FINGER ASSY
-	1			A	22374-7	VALVE, QUICK EXHAUST
-	1			A	22304-1	NIPPLE, HEX 1/8 NPT
1	1			A	690191-1	PLUG, NYLON
1	1			C	455674-1	RAM
1	1			A	690125-1	WASHER, LAMINATED
1	1			A	690124-1	WASHER, RAM
1	1			A	7-21002-9	BOLT, CRIMPER (5/16-24x1.00)
1	1			A	23241-6	BALL, STEEL
1	1			A	690170-1	SPRING, COMPRESSION
1	1			C	690142-1	DISC, INSULATION
1	1			D	354777-1	WIRE DISC, PLASTIC
1	1			A	22480-5	WASHER, SPRING
1	1			B	690212-1	POST, RAM
1	1			B	3-690451-2	SPACER, STRIPPER
1	1			A	240639-1	STRIPPER
1	1			D	455676-2	PLATE, BASE
2	2			A	22354-8	DRAG, STUD
1	1			B	455678-1	PLATE, STRIP GUIDE
2	2			A	2-22281-5	SPRING, DRAG
1	1			A	464451-1	ARM, STOCK DRAG
1	1			A	1-464452-1	DRAG, STOCK
1	1			B	5-458030-4	GUIDE, STRIP (REAR)
1	1			C	5-458031-4	GUIDE, STRIP (FRONT)
1	1			C	4-240641-7	SPACER, SLUG BLADE
1	1			B	240644-1	PLATE, REAR SHEAR
1	1			B	690482-7	PLATE, FRONT SHEAR
1	1			D	5-356038-7	ANVIL
1	1			B	690474-7	BLADE, SLUG
1	1			C	6-240641-8	SPACER, SLUG BLADE
1	1			B	238009-1	SPACER, BLOCK CRIMPER
1	1			C	1-456134-2	CRIMPER, INSULATION
1	1			B	455888-4	SPACER, CRIMPER
1	1			C	4-456408-3	CRIMPER, WIRE

QTY	REV	U/M	DWG SIZE	PART NO	DESCRIPTION	ITEM NO
2	2			C	7-354778-9	PIN, WIRE DISC (.2890)C
2	2			C	7-354778-5	PIN, WIRE DISC (.2870)B
2	2			C	6-354778-3	PIN, WIRE DISC (.2810)A
1	1			A	986950-1	WASHER, FLAT PRECISION
1	1			A	217238-1	GENERAL INSTRUCTION PACKAGE
1	1			-	4088039	EF APPL INST 408-8039
2	2			A	21024-5	WASHER, LOCK (#10)AIR ASSY
4	4			A	21024-4	WASHER, LOCK (NO.8)SHEAR BL
2	2			A	21018-4	NUT, HEX (4-40) DRAG
2	2			A	21022-2	NUT, HEX 5L (8-32)DRAG STUD
2	2			A	2-21006-6	SCR, SKT SET (4-40x.62)DRAG
1	1			A	21009-2	SCR, SKT SET (1/4-20x.25)RAM
2	2			A	21017-2	SCR, DRIVE (#2x.19) ID PLATE
1	1			B	461264-1	PLATE, IDENTIFICATION
2	2			A	2-21002-2	SCR, BHC (8-32x.50)STRIPPER
4	4			A	2-21002-9	SCR, BHC (10-32x.75)CAP
1	1			A	22733-8	SCR, BHC (8-32x.38 LW) ANVIL
4	4			A	3-21002-3	SCR, BHC (1/4-20x.50)ST 6D PL
3	3			A	2-22733-8	SCR, BHC (1/4-20x.62)H5G
4	4			A	1-21000-3	SCR, SHC (4-40x.25)DRAG
2	2			A	3-21000-0	SCR, SHC (8-32x.88)SLUG BLADE
4	4			A	2-21000-6	SCR, SHC (8-32x.38)STRIP GUIDE
2	2			A	3-21000-8	SCR, SHC (10-32x.88)SHEAR PL
1				A	455750-8	GUARD ASSY
-	REF			A	679532-1	INSERT, GUARD
1	1			A	690603-1	SPRING, ASSIST
1	1			A	23030-1	SCR, SKT CAP (6-32x.25)CP DSC

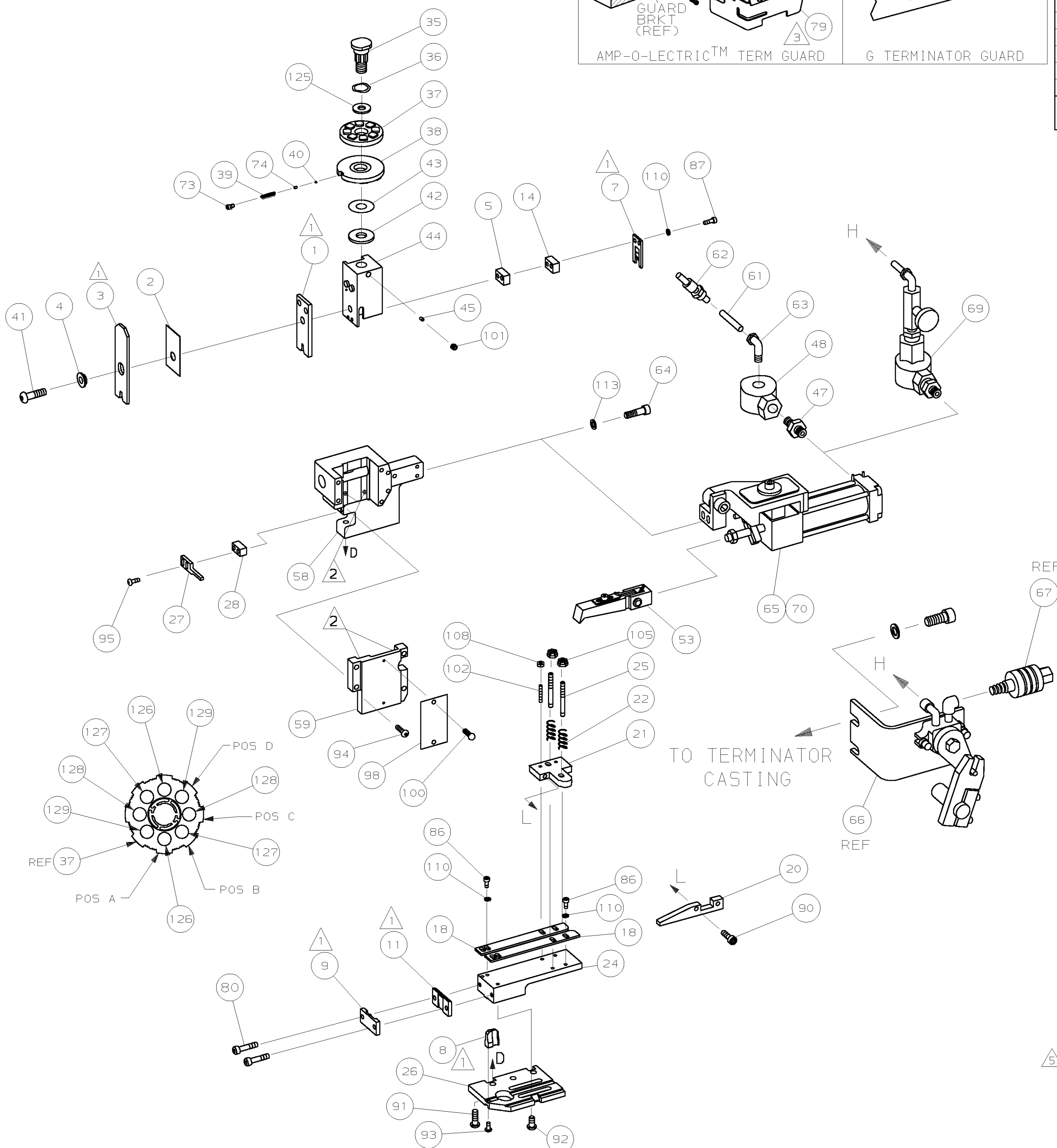

- 1 RECOMMENDED SPARE PARTS.
- 2 GREASE LIGHTLY.
- 3 GUARD MUST BE IN PLACE WHEN OPERATING APPLICATOR IN A BENCH MACHINE.
- 4 SEE DRAWING FOR COMPONENTS
- 5 ITEM 78 USED WITH G TERMINATOR ONLY.

THIS DRAWING IS A CONTROLLED DOCUMENT.

RELEASED FOR PUBLICATION BY AMP INCORPORATED. ALL RIGHTS RESERVED.

THIS DRAWING IS UNRELEASED. © COPYRIGHT 2001

LOC A DIST 66

QTY	REV	U/M	DWG SIZE	PART NO	DESCRIPTION	ITEM NO
-2	-1					

DIMENSIONS IN INCHES. DO NOT SCALE PRINT. TOLERANCES UNLESS OTHERWISE SPECIFIED:
 2 PLC DEC ±.25
 3 PLC DEC ±.125
 4 PLC DEC ±.0625
 ANGLES ±.5
 SURF TEXTURE: ✓
 REMOVE BURRS, BREAK SHARP EDGES R.015 MAX

MATL: - HT TR: - FIN: -

DR: B.HIGMAN 04DEC01 APP: T.ELBIN 04DEC01
 CHK: - REL: -

NAME: END FEED HDM APPLICATOR MACHINE REF: MINI APPL
 SCALE: - DWG NO: 1385350 SHEET: 1 OF 1 REV: E

AMP Incorporated Harrisburg, PA 17105-3608

00779 CUSTOMER AND ASSEMBLY DRAWING