



Introducing
Board-to-Board
Screw Down Jumper Assembly

Board-to-Board Screw Down Jumper Assembly

KEY FEATURES

- 2 position connection assembly
- Connector assembly attachment to adjacent printed circuit board via screw to heat sink fully seats electrical contacts against printed circuit board pads
- Connector assembly fits onto 16.50 mm [.650] wide printed circuit board
- 7.0mm [.276] printed circuit board spacing
- Registration features in connector assembly align with printed circuit board cutouts
- #6 screw (not included) used to secure connector assembly to tapped hole in heat sink or base
- #6 screw should be zinc plated or have equivalent protective coating to prevent corrosion
- Customer supplied #6 screw
- Tube packaged assemblies
- RoHS compliant

DESCRIPTIONS

The board-to-board, screw down jumper assembly provides the electrical connection between two adjacent printed circuit boards in a string of printed circuit boards.

APPLICATIONS

T8-T12 fluorescent retrofit LED bulbs
LED lighting strips
LED lighting controls
Channel lettering

ELECTRICAL

Operating Current : 5 AMPS
Operating Voltage : 250VAC/250VDC
Dielectric Withstanding Voltage : 1500 VAC

MATERIALS

Contacts : Tin plated copper alloy
Housing : UL 94 V0 Thermoplastic
ETL Recognized, File No. 3178692CRT-001 to UL (1977)

MECHANICAL

Operating Temperature : -40°C to 105°C
Mating Cycles : 10
Screw down torques : 0.11 Nm [0.97 Lb-In] max

STANDARDS AND SPECS

114-13260 : Screw Down Jumper Assembly Application Specification
108-2392 : Screw Down Jumper Assembly Product Specification

PRODUCT OFFERING

2106154-1 : Screw Down Jumper Assembly

Board-to-Board Screw Down Jumper Assembly

PRODUCT DIMENSIONS

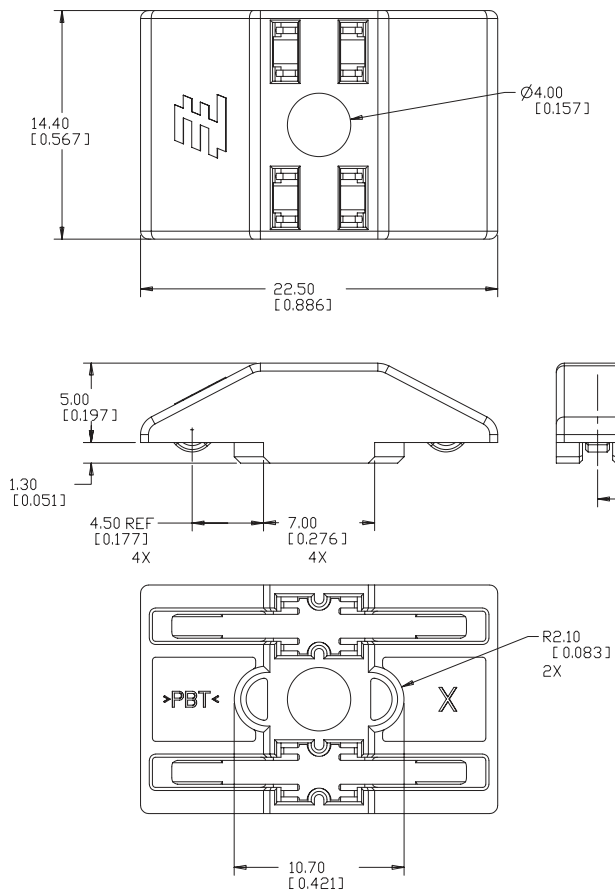

Recommended PC Board Layout

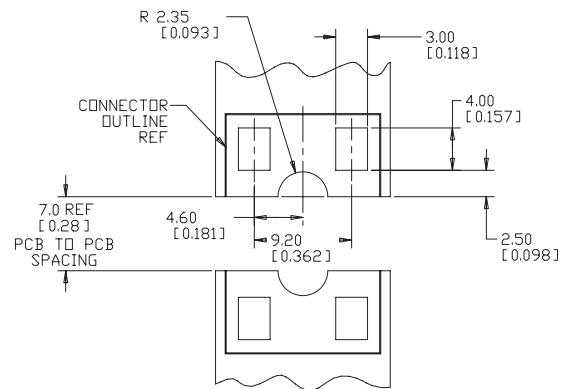

FOR MORE INFORMATION

www.tycoelectronics.com/lighting

Technical Support

Internet:	www.tycoelectronics.com/help
USA:	+1 (800) 522-6752
Canada:	+1 (905) 470-4425
Mexico & Central America:	+ 52(0) 55-1106-0814
South America:	+55 (0) 11-2103-6000
Germany:	+49 (0) 6251-133-1999
UK:	+ 44 (0) 8706-080208
France:	+33 (0) 1-3420-8686
Netherlands:	+31 (0) 73-6246-999
China:	+86 (0) 400-820-6015

Part numbers in this brochure are RoHS Compliant*, unless marked otherwise.

*as defined www.tycoelectronics.com/leadfree

Tyco Electronics Corporation

Harrisburg, PA

tycoelectronics.com

©2009 Tyco Electronics Corporation All Rights Reserved.

5-1773455-2 3M CGX 12/2009

TE (logo) and Tyco Electronics are trademarks of the Tyco Electronics group of companies and its licensors.

Other products, logos, and Company names mentioned herein may be trademarks of their respective owners.

While Tyco Electronics has made every reasonable effort to ensure the accuracy of the information in this catalog, Tyco Electronics does not guarantee that it is error-free, nor does Tyco Electronics make any other representation, warranty or guarantee that the information is accurate, correct, reliable or current. Tyco Electronics reserves the right to make any adjustments to the information contained herein at any time without notice. Tyco Electronics expressly disclaims all implied warranties regarding the information contained herein, including, but not limited to, any implied warranties of merchantability or fitness for a particular purpose. The dimensions in this catalog are for reference purposes only and are subject to change without notice. Specifications are subject to change without notice. Consult Tyco Electronics for the latest dimensions and design specifications.



Tyco Electronics
Our commitment. Your advantage.