

TLE9564QX

BLDC Motor System IC



1 Overview

Features

- Low-drop voltage regulator 5 V, 250 mA for main supply
- Three half-bridge gate drivers for external N-channel MOSFETs
- Adaptive MOSFET gate control:
 - Regulation of the MOSFET switching time
 - Reduced switching losses in PWM mode
 - High efficient constant gate charge
- Control of reverse battery protection MOSFET
- One low-side capable current sense amplifier (CSA) with configurable gain for protection and diagnosis
- LIN Transceivers LIN2.2/SAE J2602 with programmable TXD time-out feature and LIN flash mode
- Configurable wake-up sources
- Three high-side outputs 7 Ω typ.
- Six PWM inputs
 - High-side and low-side PWM capable
 - Active free-wheeling
 - Up to 25 kHz PWM frequency
- 32 bit serial peripheral interface (SPI) with cyclic redundancy check (CRC)
- Very low quiescent current consumption in Stop Mode and Sleep Mode
- Periodic cyclic sense and cyclic wake in Normal Mode, Stop Mode and Sleep Mode
- Reset and interrupt output
- Drain-source monitoring and open-load detection
- Configurable time-out and window watchdog
- Overtemperature and short circuit protection features
- Leadless power package with support of optical lead tip inspection
- Green Product (RoHS compliant)

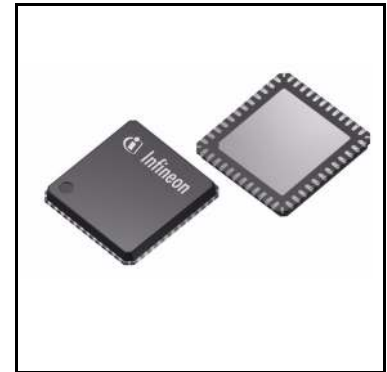

Overview

Potential applications

- Auxiliary pumps (fuel, water, etc.)
- Blower motor
- Engine cooling fan
- Sunroof module
- Transfer case

Product validation

Qualified for automotive applications. Product validation according to AEC-Q100.

Description

The TLE9564QX is a multifunctional system IC with integrated power supply, communication interfaces, multiple half-bridges and support features in an exposed pad PG-VQFN-48 power package. The device is designed for various motor control automotive applications.

To support these applications, the BLDC Motor System IC provides the main functions, such as a 5 V low-dropout voltage regulator, one LIN transceiver, three half-bridges for BDLC motor control, one current sense amplifier and one 32 bit serial peripheral interface (SPI).

The device includes diagnostic and supervision features, such as drain-source monitoring and open-load detection, short circuit protection, configurable time-out and window watchdog, as well as overtemperature protection.

Type	Package	Marking
TLE9564QX	PG-VQFN-48	TLE9564QX

Table of Contents

1	Overview	1
2	Block Diagram	7
3	Pin Configuration	8
3.1	Pin Assignment	8
3.2	Pin Definitions and Functions	8
3.3	Hints for not functional pins	10
4	General Product Characteristics	11
4.1	Absolute Maximum Ratings	11
4.2	Functional Range	13
4.3	Thermal Resistance	14
4.4	Current Consumption	14
5	System Features	18
5.1	Short State Machine Description	18
5.2	Device Configuration	19
5.3	Block Description of State Machine	21
5.4	State Machine Modes Description	22
5.4.1	Init Mode	22
5.4.2	Normal Mode	22
5.4.3	Stop Mode	23
5.4.4	Sleep Mode	24
5.4.5	Restart Mode	25
5.4.6	Fail-Safe Mode	26
5.4.7	Software Development Mode	27
5.5	Transition Between States	27
5.5.1	Transition into Init Mode	28
5.5.2	Init Mode -> Normal Mode	28
5.5.3	Normal Mode -> Stop Mode	28
5.5.4	Normal Mode -> Sleep Mode	29
5.5.5	Stop Mode -> Normal Mode	29
5.5.6	Sleep Mode -> Restart Mode	30
5.5.7	Restart Mode -> Normal Mode	30
5.5.8	Fail-Safe Mode -> Restart Mode	30
5.6	Reaction on Detected Faults	31
5.6.1	Stay in Current State	31
5.6.2	Transition into Restart Mode	31
5.6.3	Transition into Fail-Safe Mode	33
5.7	Wake Features	33
5.7.1	Cyclic Sense	34
5.7.1.1	Configuration and Operation of Cyclic Sense	34
5.7.1.2	Cyclic Sense in Low-power Mode	38
5.7.2	Cyclic Wake	38
5.7.3	Internal Timers	39
5.8	VS Supply Multiplexing	40
6	Voltage Regulator 1	41
6.1	Block Description	41

6.2	Functional Description	42
6.3	Electrical Characteristics	43
7	High-Side Switch	45
7.1	Block Description	45
7.2	Functional Description	45
7.2.1	Under Voltage Switch Off	45
7.2.2	Over Voltage Switch Off	46
7.2.3	Over Current Detection and Switch Off	46
7.2.4	Open Load Detection	46
7.2.5	PWM, Timer and SYNC Function	46
7.3	Electrical Characteristics	48
8	LIN Transceiver	49
8.1	Block Description	49
8.1.1	LIN Specifications	49
8.2	Functional Description	50
8.2.1	LIN OFF Mode	50
8.2.2	LIN Normal Mode	50
8.2.3	LIN Receive Only Mode	51
8.2.4	LIN Wake Capable Mode	51
8.2.5	TXD Time-out Feature	52
8.2.6	Bus Dominant Clamping	53
8.2.7	Under-Voltage Detection	53
8.2.8	Slope Selection	53
8.2.9	Flash Programming via LIN	53
8.3	Electrical Characteristics	54
9	High-Voltage Wake Input	59
9.1	Block Description	59
9.2	High-Voltage Wake Function	60
9.2.1	Functional Description	60
9.2.2	Wake Input Configuration	60
9.2.3	Wake configuration for Cyclic Sense	61
9.2.4	Wake configuration for Synchronization	61
9.3	Electrical Characteristics	62
10	Interrupt Function	63
10.1	Block and Functional Description	63
10.2	Electrical Characteristics	66
11	Gate Drivers	67
11.1	MOSFET control	67
11.2	Static activation	68
11.2.1	Static activation of a high-side MOSFET	69
11.2.2	Static activation of a low-side MOSFET	72
11.2.3	Turn-off of the high-side and low-side MOSFETs of a half-bridge	72
11.3	PWM operation	73
11.3.1	Determination of the active and freewheeling MOSFET	73
11.3.2	Configurations in PWM mode	73
11.3.3	PWM operation with 3 PWM inputs	76

11.3.3.1	Control signals with active free-wheeling (AFW _x = 1)	77
11.3.3.2	Control signals with passive free-wheeling (AFW _x = 0)	82
11.3.3.3	Time modulation of pre-charge and pre-discharge times	86
11.3.3.4	Operation at high and low duty cycles	89
11.3.3.5	Measurements of the switching times	89
11.3.4	PWM operation with 6 PWM inputs	90
11.3.5	Status bits for regulation of turn-on and turn-off delay times	95
11.3.6	Gate driver current	97
11.4	Passive discharge	102
11.5	Slam mode	103
11.6	Parking braking mode	103
11.7	Charge pump	104
11.8	Frequency modulation	105
11.9	Electrical characteristics gate driver	106
12	Supervision Functions	114
12.1	Reset Function	114
12.1.1	Reset Output Description	114
12.1.2	Soft Reset Description	115
12.2	Watchdog Function	116
12.2.1	Time-Out Watchdog	117
12.2.2	Window Watchdog	118
12.2.3	Watchdog Setting Check Sum	118
12.2.4	Watchdog during Stop Mode	119
12.2.5	Watchdog Start in Stop Mode due to Bus Wake	119
12.3	VSINT Power On Reset	120
12.4	VSINT Under- and Overvoltage	121
12.4.1	VSINT Undervoltage	121
12.4.2	VSINT Overvoltage	121
12.5	VS Under- and Overvoltage	122
12.5.1	VS Undervoltage	122
12.5.2	VS Overvoltage	122
12.6	VS Under- Overvoltage for high-side	123
12.6.1	VS Undervoltage for high-side	123
12.6.2	VS Overvoltage for high-side	123
12.7	VCC1 Over-/ Undervoltage and Undervoltage Prewarning	124
12.7.1	VCC1 Undervoltage and Undervoltage Prewarning	124
12.7.2	VCC1 Overvoltage	125
12.8	VCC1 Short Circuit Diagnostics	125
12.9	Thermal Protection	126
12.9.1	Individual Thermal Shutdown	126
12.9.2	Temperature Prewarning	126
12.9.3	Thermal Shutdown	126
12.10	Bridge driver	128
12.10.1	Bridge driver supervision with activated charge pump	128
12.10.1.1	Drain-source voltage monitoring	128
12.10.1.2	Cross-current protection and drain-source overvoltage blank time	129
12.10.1.3	OFF-state diagnostic	130

12.10.1.4	Charge pump undervoltage	131
12.10.1.5	Switching parameters of MOSFETs in PWM mode	131
12.10.2	Low-side drain-source voltage monitoring during braking	131
12.10.3	VS or VSINT Overvoltage braking	132
12.11	Current sense amplifier	132
12.11.1	Unidirectional and bidirectional operation	132
12.11.2	Gain configuration	133
12.11.3	Overcurrent Detection	133
12.11.4	CSO output capacitor	135
12.12	Electrical Characteristics	136
13	Serial Peripheral Interface	144
13.1	SPI Block Description	144
13.2	Failure Signalization in the SPI Data Output	145
13.3	SPI Programming	147
13.3.1	CRC	148
13.4	SPI Bit Mapping	150
13.4.1	Register Banking	151
13.5	SPI control registers	153
13.5.1	Device Control Registers	155
13.5.2	Control registers bridge driver	174
13.6	SPI status information registers	195
13.6.1	Device Status Registers	196
13.6.2	Status registers bridge driver	206
13.6.3	Family and product information register	218
13.7	Electrical Characteristics	219
14	Application Information	221
14.1	Application Diagrams	221
14.2	ESD Tests	224
14.2.1	ESD according to IEC61000-4-2	224
14.2.2	ESD according to SAE J2962	224
14.3	Thermal Behavior of Package	225
14.4	Further Application Information	225
15	Package Outlines	226
16	Revision History	227

Block Diagram

2 Block Diagram

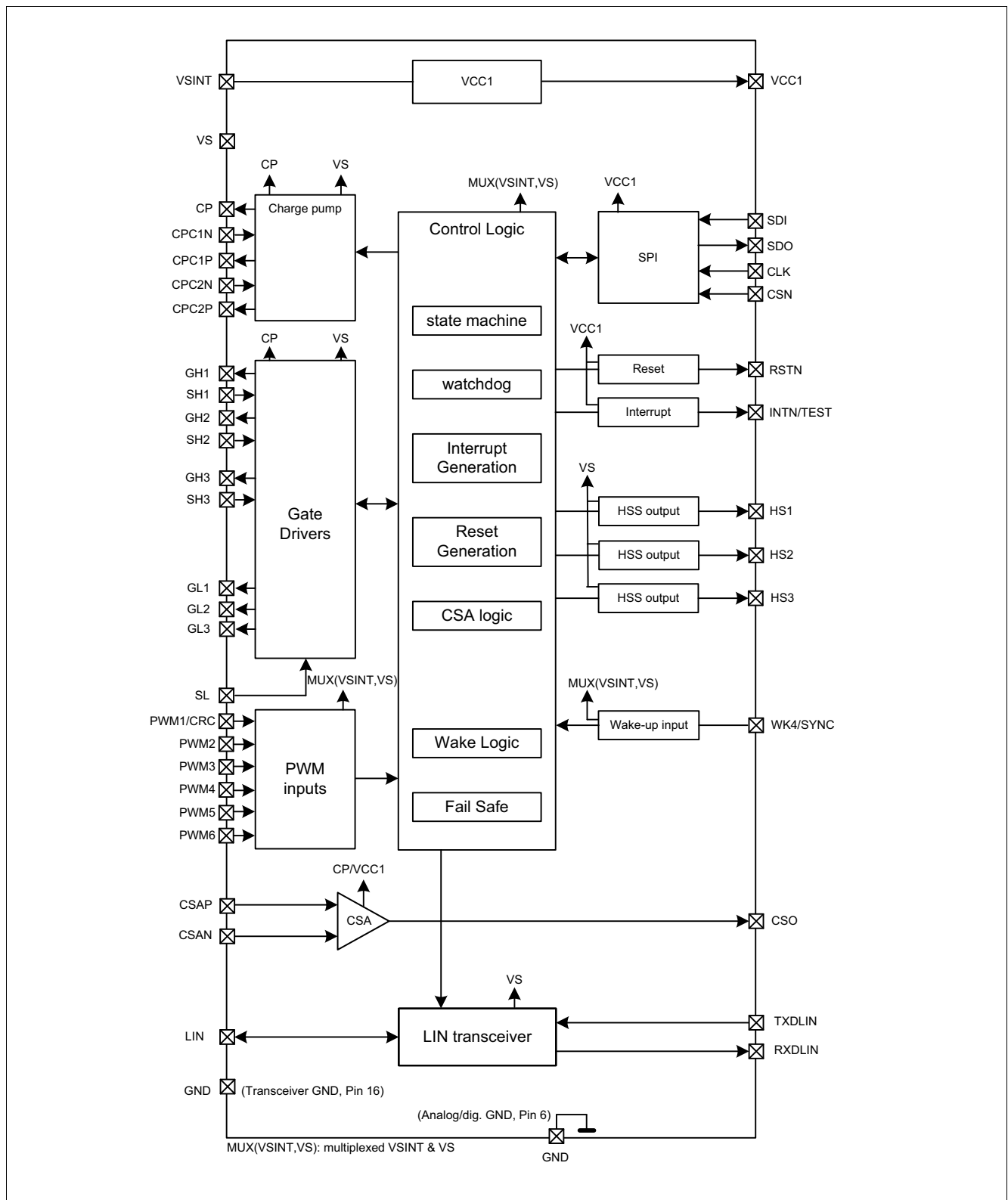

Figure 1 Block Diagram

Pin Configuration

3 Pin Configuration

3.1 Pin Assignment

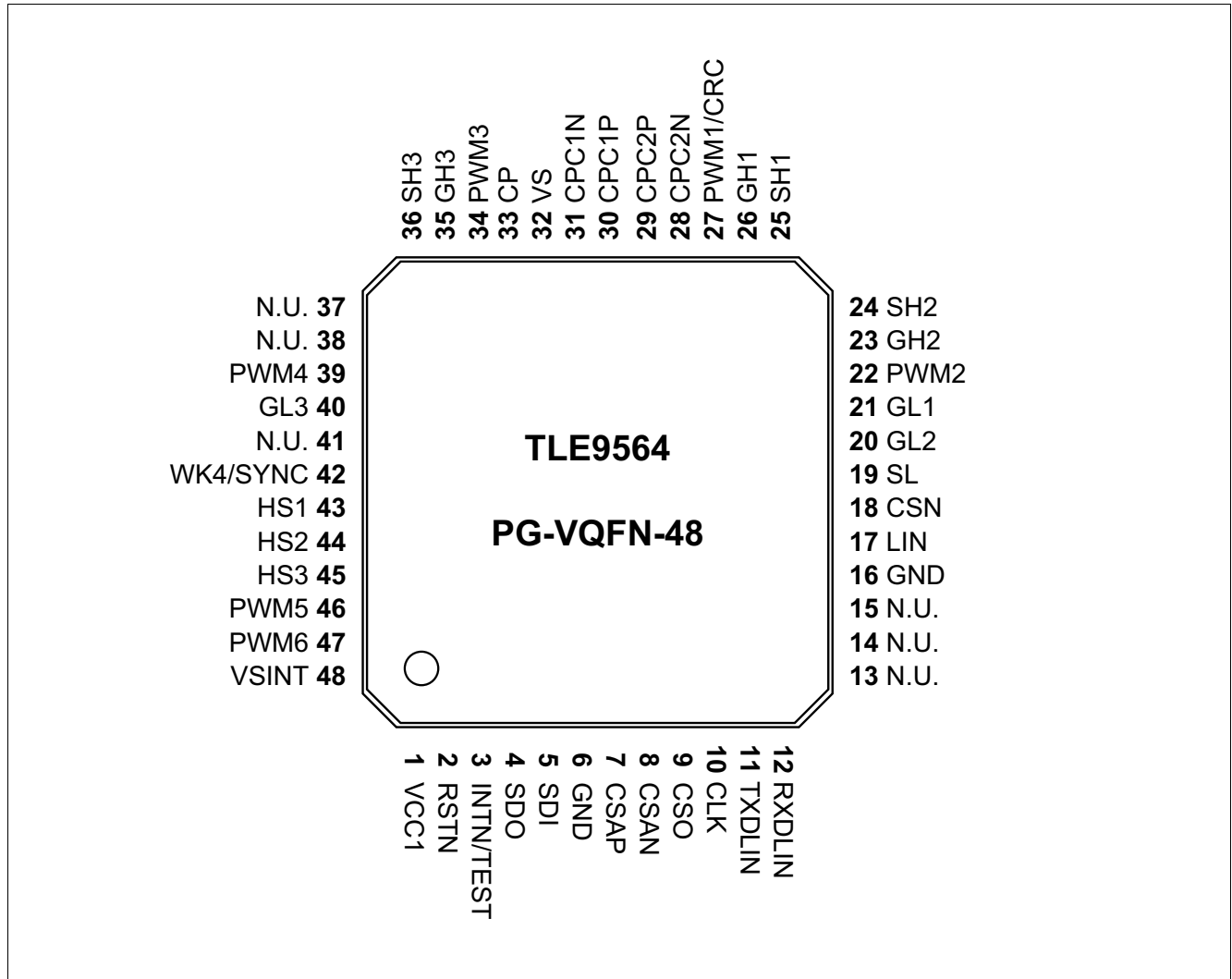

Figure 2 Pin Configuration

3.2 Pin Definitions and Functions

Pin	Symbol	Function
1	VCC1	Voltage Regulator. Output voltage 1
2	RSTN	Reset Output. Active LOW, internally passive pull-up with open-drain output
3	INTN/TEST	Interrupt Output. Active LOW output, push-pull structure TEST. Connect to GND (via pull-down) to activate Software Development Mode
4	SDO	SPI Data Output to Microcontroller (=MISO). Push-pull structure
5	SDI	SPI Data Input from Microcontroller (=MOSI). Internal pull-down
6	GND	Ground. Analog/digital ground
7	CSAP	Not Inverting input of Current Sense Amplifier.

Pin Configuration

Pin	Symbol	Function
8	CSAN	Inverting input of Current Sense Amplifier.
9	CSO	Current Sense Amplifier Output.
10	CLK	SPI Clock Input. Internal passive pull-down
11	TXDLIN	Transmit LIN. Internal passive pull-up
12	RXDLIN	Receive LIN. Push-pull structure
13	N.U.	Not used.
14	N.U.	Not used.
15	N.U.	Not used.
16	GND	Ground. Transceiver ground (, LIN)
17	LIN	LIN Bus.
18	CSN	SPI Chip Select Not input. Internal passive pull-up
19	SL	Source Low Side.
20	GL2	Gate Low Side 2.
21	GL1	Gate Low Side 1.
22	PWM2	PWM input 2. Internal passive pull-up
23	GH2	Gate High Side 2.
24	SH2	Source High Side 2.
25	SH1	Source High Side 1.
26	GH1	Gate High Side 1.
27	PWM1/CRC	PWM input 1. Internal passive pull-down CRC. Connect to GND (via pull-down) to activate CRC functionality
28	CPC2N	Negative connection to Charge Pump Capacitor 2.
29	CPC2P	Positive connection to Charge Pump Capacitor 2.
30	CPC1P	Positive connection to Charge Pump Capacitor 1.
31	CPC1N	Negative connection to Charge Pump Capacitor 1.
32	VS	Supply voltage for HSx, LIN, Bridge Drivers and Charge pump. Connected to the battery voltage after reverse protection.
33	CP	Charge Pump output voltage.
34	PWM3	PWM input 3. Internal passive pull-down
35	GH3	Gate High Side 3.
36	SH3	Source High Side 3.
37	N.U.	Not used.
38	N.U.	Not used.
39	PWM4	PWM input 4. Internal passive pull-down
40	GL3	Gate Low Side 3.
41	N.U.	Not used.
42	WK4/SYNC	Wake-up input 4/Sync.
43	HS1	High Side output 1.
44	HS2	High Side output 2.

Pin Configuration

Pin	Symbol	Function
45	HS3	High Side output 3.
46	PWM5	PWM input 5. Internal passive pull-down
47	PWM6	PWM input 6. Internal passive pull-down
48	VSINT	Voltage regulator and main supply voltage. Connected to the battery voltage after reverse protection
Cooling Tab	GND	Cooling Tab - Exposed Die Pad; For cooling purposes only, do not use as an electrical ground ¹⁾

1) The exposed die pad at the bottom of the package allows better power dissipation of heat from the device via the PCB. The exposed die pad is not connected to any active part of the IC. However, it should be connected to GND for the best EMC performance.

Note: The GND pin as well as the Cooling Tab must be connected to one common GND potential.

3.3 Hints for not functional pins

It must be ensured that the correct configurations are also selected, i.e. in case functions are not used that they are disabled via SPI. Unused pins should be handled as follows:

- **N.U.:** not used; internally bonded for testing purpose; leave open.
- **RSVD:** must be connected to GND.

General Product Characteristics

4 General Product Characteristics

4.1 Absolute Maximum Ratings

Table 1 Absolute Maximum Ratings¹⁾

$T_j = -40^\circ\text{C}$ to $+150^\circ\text{C}$; all voltages with respect to ground, positive current flowing into pin (unless otherwise specified)

Parameter	Symbol	Values			Unit	Note or Test Condition	Number
		Min.	Typ.	Max.			
Voltages							
Supply Voltage VS	$V_{S, \max}$	-0.3	-	28	V	-	P_4.1.1
Supply Voltage VS	$V_{S, \max}$	-0.3	-	40	V	Load Dump	P_4.1.2
Supply Voltage VSINT	$V_{SINT, \max}$	-0.3	-	28	V	-	P_4.1.3
Supply Voltage VSINT	$V_{SINT, \max}$	-0.3	-	40	V	Load Dump	P_4.1.4
Voltage Regulator 1	$V_{CC1, \max}$	-0.3	-	5.5	V		P_4.1.7
Charge Pump Output Pin (CP)	$V_{CP, \max}$	$V_S - 0.8$	-	$V_S + 17$	V	$I_{CP} > -200 \mu\text{A}$ if CP is disabled	P_4.1.8
CPC1P, CPC2P	$V_{CPCxP, \max}$	-0.3	-	$V_S + 17$	V		P_4.1.38
CPC1N, CPC2N	$V_{CPCxN, \max}$	-0.3	-	$V_S + 0.3$	V		P_4.1.39
Bridge Driver Gate High Side (GHx)	$V_{GHx, \max}$	-8.0	-	40	V	-	P_4.1.11
Bridge Driver Gate Low Side (GLx)	$V_{GLx, \max}$	-8.0	-	24	V	-	P_4.1.12
Voltage difference between GHx-SHx and between GLx-SLx	V_{GS}	-0.3	-	16	V	-	P_4.1.13
Bridge Driver Source High (SHx)	$V_{SHx, \max}$	-8.0	-	40	V	-	P_4.1.14
Bridge Driver Source Low Side SL	$V_{SL, \max}$	-8.0	-	6.0	V	-	P_4.1.15
Current Sense Amplifier inputs (CSAP, CSAN)	$V_{CSx, \max}$	-8.0	-	+8.0	V	-	P_4.1.16
Current Sense Amplifier Output CSO	$V_{CSx, \max}$	-0.3	-	$V_{CC1} + 0.3$	V	-	P_4.1.17
Differential input voltage range CSAPx - CSANx	$V_{CSA, \text{Diff}}$	-8.0	-	8.0	V	-	P_4.1.18
Wake Input WKx	$V_{WKx, \max}$	-0.3	-	40	V	-	P_4.1.19
High Side HSx	$V_{HSx, \max}$	-0.3	-	$V_{S, \max} + 0.3$	V	-	P_4.1.20
LIN bus	$V_{LIN, \max}$	-27	-	40	V	-	P_4.1.21

General Product Characteristics

Table 1 Absolute Maximum Ratings¹⁾ (cont'd)

$T_j = -40^{\circ}\text{C}$ to $+150^{\circ}\text{C}$; all voltages with respect to ground, positive current flowing into pin (unless otherwise specified)

Parameter	Symbol	Values			Unit	Note or Test Condition	Number
		Min.	Typ.	Max.			
PWM1/CRC, PWM2, PWM3, PWM4, PWM 5, PWM6 Input Pins	$V_{\text{PWM1-2-3-4-5-6, max}}$	-0.3	–	40	V	–	P_4.1.25
Logic Input Pins (SDI, CLK,)	$V_{\text{I, max}}$	-0.3	–	$V_{\text{CC1}} + 0.3$	V	–	P_4.1.28
CSN	V_{CSN}	-0.3	–	40	V	–	P_4.1.29
Logic Output Pins (SDO, RSTN, INTN, , RXDLIN)	$V_{\text{O, max}}$	-0.3	–	$V_{\text{CC1}} + 0.3$	V	–	P_4.1.30

Temperatures

Junction Temperature	T_j	-40	–	150	$^{\circ}\text{C}$	–	P_4.1.32
Storage Temperature	T_{stg}	-55	–	150	$^{\circ}\text{C}$	–	P_4.1.33

ESD Susceptibility

ESD Resistivity	$V_{\text{ESD,11}}$	-2	–	2	kV	HBM ²⁾	P_4.1.34
ESD Resistivity to GND, LIN	$V_{\text{ESD,12}}$	-8	–	8	kV	HBM ²⁾³⁾	P_4.1.35
ESD Resistivity to GND	$V_{\text{ESD,21}}$	-500	–	500	V	CDM ⁴⁾	P_4.1.36
ESD Resistivity Pin 1, 12,13,24,25,36,37,48 (corner pins) to GND	$V_{\text{ESD,22}}$	-750	–	750	V	CDM ⁴⁾	P_4.1.37

1) Not subject to production test, specified by design.

2) ESD susceptibility, HBM according to ANSI/ESDA/JEDEC JS-001 (1.5 k Ω , 100 pF).

3) For ESD “GUN” Resistivity (according to IEC61000-4-2 “gun test” (150 pF, 330 Ω)), is shown in Application Information and test report will be provided from IBEE.

4) ESD susceptibility, Charged Device Model “CDM” EIA/JESD22-C101 or ESDA STM5.3.1.

Notes

1. Stresses above the ones listed here may cause permanent damage to the device. Exposure to absolute maximum rating conditions for extended periods may affect device reliability.
2. Integrated protection functions are designed to prevent IC destruction under fault conditions described in the data sheet. Fault conditions are considered as “outside” normal operating range. Protection functions are not designed for continuous repetitive operation.

General Product Characteristics

4.2 Functional Range

Table 2 Functional Range¹⁾

Parameter	Symbol	Values			Unit	Note or Test Condition	Number
		Min.	Typ.	Max.			
Supply Voltage	$V_{SINT,func}$	$V_{POR,f}$	–	28	V	2)	P_4.2.1
Bridge Supply Voltage	$V_{S,func}$	6.0	–	28	V	–	P_4.2.2
LIN Bus Voltage	$V_{S_LIN,func}$	6	–	18	V	3)	P_4.2.3
Junction Temperature	T_j	-40	–	150	°C	–	P_4.2.6

- 1) Not subject to production test, specified by design.
- 2) Including Power-On Reset, Over- and Undervoltage Protection.
- 3) Parameter specification according to ISO 17987-4: rev 2016.

Note: Within the functional range the IC operates as described in the circuit description. The electrical characteristics are specified within the conditions given in the related electrical characteristics table.

Device Behavior Outside of Specified Functional Range

- $28\text{ V} < V_{SINT,func} < 40\text{ V}$: Device will still be functional including the state machine; the specified electrical characteristics might not be ensured anymore. The V_{CC1} is working properly, however, a thermal shutdown might occur due to high power dissipation. HSx switches might be turned OFF depending on HSx_OV configurations. The specified SPI communication speed is ensured; the absolute maximum ratings are not violated, however the device is not intended for continuous operation of $V_{SINT} > 28\text{ V}$ and a thermal shutdown might occur due to high power dissipation. The device operation at high junction temperatures for long periods might reduce the operating life time.

Note: $18\text{ V} < V_S < 28\text{ V}$: The LIN transceiver is still functional. However, the communication might fail due to out-of-LIN-spec operation.

Note: $V_{S,uv} < V_S < 6\text{ V}$: The LIN transceiver is still functional. However, the communication might fail due to out-of-LIN-spec operation.

- $V_{POR,f} < V_{SINT} < 5.5\text{ V}$ (given the fact that the device was powered up correctly before with $V_{SINT} > 5.5\text{ V}$): Device will still be functional; the specified electrical characteristics might not be ensured anymore:
 - The voltage regulator will enter the low-drop operation mode.
 - A reset could be triggered depending on the Vrthx settings.
 - The LIN transmitter will be disabled if $V_{S,uv}$ is reached. .
 - HSx switch behavior will depend on the respective configuration:
HS_UV_SD_DIS = '0' (default): HSx will be turned OFF for $V_S < V_{S,UVD}$ and will stay OFF.
HS_UV_SD_DIS = '1': HSx stays on as long as possible. An unwanted overcurrent shut down may occur. OC shut down bit set and the respective HSx switch will stay OFF.
 - The specified SPI communication speed is ensured.

Note: $V_{S,uv} < V_S < 6.0\text{ V}$: the charge pump might be deactivated due to a charge pump undervoltage detection, resulting in a turn-off of the external MOSFETs.

General Product Characteristics

4.3 Thermal Resistance

Table 3 Thermal Resistance¹⁾

Parameter	Symbol	Values			Unit	Note or Test Condition	Number
		Min.	Typ.	Max.			
Junction to Soldering Point	$R_{th(JSP)}$	–	7.2	–	K/W	Exposed Pad	P_4.3.1
Junction to Ambient	$R_{th(JA)}$	–	27	–	K/W	²⁾	P_4.3.2

1) Not subject to production test, specified by design.

2) Specified $R_{th(JA)}$ value is according to Jedec JESD51-2,-5,-7 at natural convection on FR4 2s2p board for a power dissipation of 1.5 W; the product (chip+package) was simulated on a 76.2 x 114.3 x 1.5 mm³ with 2 inner copper layers (2 x 70 μm Cu, 2 x 35 μm C); where applicable a thermal via array under the exposed pad contacted the first inner copper layer and 300 mm² cooling areas on the top layer and bottom layers (70 μm).

4.4 Current Consumption

Table 4 Current Consumption

Current consumption values are specified at $T_j = 25^\circ\text{C}$, $V_{SINT} = V_S = 13.5\text{ V}$, all outputs open (unless otherwise specified)

Parameter	Symbol	Values			Unit	Note or Test Condition	Number
		Min.	Typ.	Max.			
Normal Mode							
Normal Mode current consumption	I_{Normal}	–	4.5	5.5	mA	¹⁾ $V_{SINT} = 5.5\text{ V to }28\text{ V}$; $T_j = -40^\circ\text{C to }+150^\circ\text{C}$; LIN=CP=off	P_4.4.1
Stop Mode							
Stop Mode current consumption (low active peak threshold)	$I_{Stop_1,25}$	–	50	65	μA	¹⁾²⁾ CSA=LIN=off; WKx=HSx=CP=off; Cyclic Wak./Sen.=off Watchdog = off; no load on V_{CC1} ; I_PEAK_TH = 0 _B	P_4.4.2
Stop Mode current consumption (low active peak threshold)	$I_{Stop_1,85}$	–	55	80	μA	¹⁾²⁾³⁾ $T_j = 85^\circ\text{C}$; CSA=LIN=off; WKx=HSx=CP=off; Cyclic Wak./Sen.=off Watchdog = off; no load on V_{CC1} ; I_PEAK_TH = 0 _B	P_4.4.3
Stop Mode current consumption (high active peak threshold)	$I_{Stop_2,25}$	–	70	95	μA	¹⁾²⁾ CSA=LIN=off; WKx=HSx=CP=off; Cyclic Wak./Sen.=off Watchdog = off; no load on V_{CC1} ; I_PEAK_TH = 1 _B	P_4.4.4

General Product Characteristics

Table 4 Current Consumption (cont'd)

Current consumption values are specified at $T_j = 25^\circ\text{C}$, $V_{\text{SINT}} = V_S = 13.5\text{ V}$, all outputs open (unless otherwise specified)

Parameter	Symbol	Values			Unit	Note or Test Condition	Number
		Min.	Typ.	Max.			
Stop Mode current consumption (high active peak threshold)	$I_{\text{Stop}_2,85}$	–	75	105	μA	¹⁾²⁾³⁾ $T_j = 85^\circ\text{C}$; CSA=LIN=off; Cyclic Wak./Sen.=off; Watchdog = off; no load on V_{CC1} ; I_PEAK_TH = 1 _B	P_4.4.5

Sleep Mode

Sleep Mode current consumption	$I_{\text{Sleep},25}$	–	18	30	μA	¹⁾ CSA=LIN=off; WKx=HSx=CP=off; Cyclic Wak./Sen.= off	P_4.4.6
Sleep Mode current consumption	$I_{\text{Sleep},85}$	–	28	40	μA	¹⁾³⁾ $T_j = 85^\circ\text{C}$; CSA=LIN=off; WKx=HSx=CP=off; Cyclic Wak./Sen.=off	P_4.4.7

Feature Incremental Current Consumption

Current consumption for LIN module, recessive state	$I_{\text{LIN,rec}}$	–	1.0	1.2	mA	³⁾⁴⁾ Normal/Stop Mode; LIN Normal Mode; $T_j = -40^\circ\text{C}$ to $+150^\circ\text{C}$; $V_{\text{TXDLIN}} = V_{\text{CC1}}$; no RL on LIN	P_4.4.8
Current consumption for LIN module, dominant state	$I_{\text{LIN,dom}}$	–	1.5	1.7	mA	³⁾⁴⁾ Normal/Stop Mode; LIN Normal Mode; $T_j = -40^\circ\text{C}$ to $+150^\circ\text{C}$; $V_{\text{TXDLIN}} = \text{GND}$; no RL on LIN	P_4.4.9
Current consumption for LIN module, Receive Only Mode, Normal Mode	$I_{\text{LIN,Rec_onlyN}}$	–	0.1	0.2	mA	³⁾⁴⁾ Normal Mode; LIN Receive Only Mode; $V_{\text{TXDLIN}} = V_{\text{CC1}}$ no RL on LIN	P_4.4.10
Current consumption for LIN wake capability	$I_{\text{LIN,wake},25}$	–	0.2	2	μA	⁴⁾ Stop/Sleep Mode; LIN wake capable;	P_4.4.11
Current consumption for LIN wake capability	$I_{\text{LIN,wake},85}$	–	2	3	μA	³⁾⁴⁾ Stop/Sleep Mode; $T_j = 85^\circ\text{C}$; LIN wake capable;	P_4.4.12
Current consumption for each WK input	$I_{\text{WK,wake},25}$	–	0.2	2	μA	¹⁾⁵⁾⁶⁾⁷⁾ Sleep Mode; WK wake capable; no activity on WK pin;	P_4.4.22

General Product Characteristics

Table 4 Current Consumption (cont'd)

Current consumption values are specified at $T_j = 25^\circ\text{C}$, $V_{\text{SINT}} = V_S = 13.5\text{ V}$, all outputs open (unless otherwise specified)

Parameter	Symbol	Values			Unit	Note or Test Condition	Number
		Min.	Typ.	Max.			
Current consumption for each WK input	$I_{\text{WK,wake,85}}$	–	0.5	3	μA	¹⁾³⁾⁵⁾⁶⁾⁷⁾ Sleep Mode; $T_j = 85^\circ\text{C}$; WK wake capable; no activity on WK pin;	P_4.4.23
Current consumption for first High-Side in Stop Mode	$I_{\text{Stop,HS,25}}$	–	250	375	μA	³⁾⁵⁾⁸⁾¹⁰⁾⁹⁾ Stop Mode; HS with 100% duty cycle (no load);	P_4.4.24
Current consumption for first High-Side in Stop Mode	$I_{\text{Stop,HS,85}}$	–	250	375	μA	³⁾⁵⁾⁸⁾¹⁰⁾⁹⁾ Stop Mode; $T_j = 85^\circ\text{C}$; HS with 100% duty cycle (no load);	P_4.4.25
Current consumption for cyclic sense function	$I_{\text{Stop,CS25}}$	–	20	26	μA	⁵⁾⁸⁾¹⁰⁾¹¹⁾ Stop Mode; WD = off;	P_4.4.26
Current consumption for cyclic sense function	$I_{\text{Stop,CS85}}$	–	24	32	μA	³⁾⁵⁾⁸⁾¹⁰⁾¹¹⁾ Stop Mode; $T_j = 85^\circ\text{C}$; WD = off;	P_4.4.27
Current consumption for watchdog active in Stop Mode	$I_{\text{Stop,WD25}}$	–	18	23	μA	³⁾¹²⁾ Stop Mode; Watchdog running;	P_4.4.28
Current consumption for watchdog active in Stop Mode	$I_{\text{Stop,WD85}}$	–	19	25	μA	³⁾¹²⁾ Stop Mode; $T_j = 85^\circ\text{C}$; Watchdog running;	P_4.4.29
Current Sense Amplifier	I_{CSA1}	–	–	4	mA	¹²⁾ CSA_OFF = 0 _B ; VCSP = VCSAP = VCSAN = 0 V; CSO_CAP = 0 _B ; CCSO = 330 pF	P_4.4.31
Current Sense Amplifier	I_{CSA2}	–	–	10	mA	¹²⁾ CSA_OFF = 0 _B ; VCSP = VCSAP = VCSAN = 0 V; CSO_CAP = 1 _B ; CCSO = 2.2 nF	P_4.4.36
Current consumption in parking braking mode (LSx ON)	I_{parking}	–	10	14	μA	³⁾¹²⁾ Stop Mode or Sleep Mode; $T_j < 85^\circ\text{C}$; PARK_BRK_EN = 1 _B	P_4.4.32
Current consumption Over voltage braking mode (LSx OFF)	$I_{\text{OV,LS_OFF}}$	–	7	10	μA	³⁾¹²⁾ Stop Mode or Sleep Mode; $T_j < 85^\circ\text{C}$; OV_BRK_EN = 1 _B	P_4.4.34
Current consumption in VS for Charge Pump and Bridge Driver	$I_{\text{CP,BD}}$	–	30	40	mA	Normal Mode; $T_j = -40^\circ\text{C}$ to $+150^\circ\text{C}$; CPEN = 1; All HB OFF	P_4.4.35

1) Measured at V_{SINT} .

General Product Characteristics

- 2) If the load current on V_{CC1} will exceed the configured V_{CC1} active peak threshold, the current consumption will increase by typ. 2.9 mA to ensure optimum dynamic load behavior. See also [Chapter 6](#).
- 3) Not subject to production test, specified by design.
- 4) Additional current will be drawn from V_S .
- 5) Current consumption adders of features defined for Stop Mode also apply for Sleep Mode and vice versa. Wake input signals are stable (i.e. not toggling), cyclic wake/sense & watchdog are OFF (unless otherwise specified).
- 6) No pull-up or pull-down configuration selected.
- 7) The specified WKx current consumption adder for wake capability applies regardless how many WK inputs are activated.
- 8) Additional current will be drawn from V_S and V_{SINT} .
- 9) Typical adder of additional high-side switch activation 200 μ A.
- 10) HSx used for cyclic sense, Timerx with 20ms period, 0.1 ms on-time, no load.
In general the current consumption adder for cyclic sense in Stop Mode can be calculated with below equation:
$$I_{\text{Stop,CS_typ}} = 18 \mu\text{A} + (I_{\text{Stop,HS,25}} \times t_{\text{on}}/T_{\text{Per}})$$
where the 18 uA is the base current consumption of the digital cyclic sense/wake functionality.
- 11) Also applies to cyclic wake but without adder from HS biasing contribution.
- 12) Additional current will be drawn from V_{SINT} .

Notes

1. *There is no additional current consumption contribution in Normal Mode due to PWM generators or Timers.*
2. *The quiescent current consumption in Stop Mode and Sleep Mode will increase for $V_{SINT} < 9$ V.*

5 System Features

This chapter describes the system features and behavior of the TLE9564QX:

- State machine
- Device configuration
- State machine modes and mode transitions
- Wake-up features such as cyclic sense and cyclic wake

5.1 Short State Machine Description

The BLDC Motor System IC offers six operating modes:

- Init Mode: Power-up of the device and after a soft reset.
- Normal Mode: The main operating mode of the device.
- Stop Mode: The first-level power saving mode with the main voltage regulator VCC1 enabled.
- Sleep Mode: The second-level power saving mode with VCC1 disabled.
- Restart Mode: An intermediate mode after a wake event from Sleep Mode or Fail-Safe Mode or after a failure (e.g. WD failure, VCC1 under voltage reset) to bring the microcontroller into a defined state via a reset.
- Fail-Safe Mode: A safe-state mode after critical failures (e.g. Temperature shutdown) to bring the system into a safe state and to ensure a proper restart of the system.

A special mode, called Software Development Mode, is available during software development or debugging of the system. All above mentioned operating modes can be accessed in this mode. However, the watchdog is still running, but no reset to the microcontroller is applied. Watchdog failures are indicated over INTN pin instead.

However, the watchdog reset signaling can be reactivated again in Software Development Mode. The Watchdog will start always with the Long Open Windows (t_{low}).

The BLDC Motor System IC is controlled via a 32-bit SPI interface (refer to [Chapter 13](#) for detailed information). The configuration as well as the diagnosis is handled via the SPI.

The device offers various supervision features to support functional safety requirements. Refer to [Chapter 12](#) for more information.

System Features

5.2 Device Configuration

Two features on the BLDC Motor System IC can be configured by hardware:

- The selection of the normal device operation or the Software Development Mode.
- Enabling/disabling the CRC on the SPI interface.

The configurations are done monitoring the follow pins:

- INTN/TEST
- PWM1/CRC

The hardware configuration can be done typically at device power-up, where the device is in Init Mode or (only in case of CRC setting) in Restart Mode.

Software development Mode configuration detail

After the RSTN is released, the INTN/TEST pin is internally pulled HIGH with a weak pull-up resistor. Therefore the default configuration is the device in normal operation.

In order to configure the Software Development Mode, the following conditions have to be fulfilled:

- Init Mode from power-up
- $VCC1 > V_{rtx}$
- **POR**=1
- RSTN = HIGH

The Software Development Mode is configured using the following scheme:

- Only one external pull-down on INTN/TEST pin followed by an arbitrary SPI command, the device latches the Software Development Mode.
- External pull-up or no pull-down on INTN/TEST pin enable the device in normal operation.
- To enter Software Development Mode, a pull-down resistor to GND might be used.

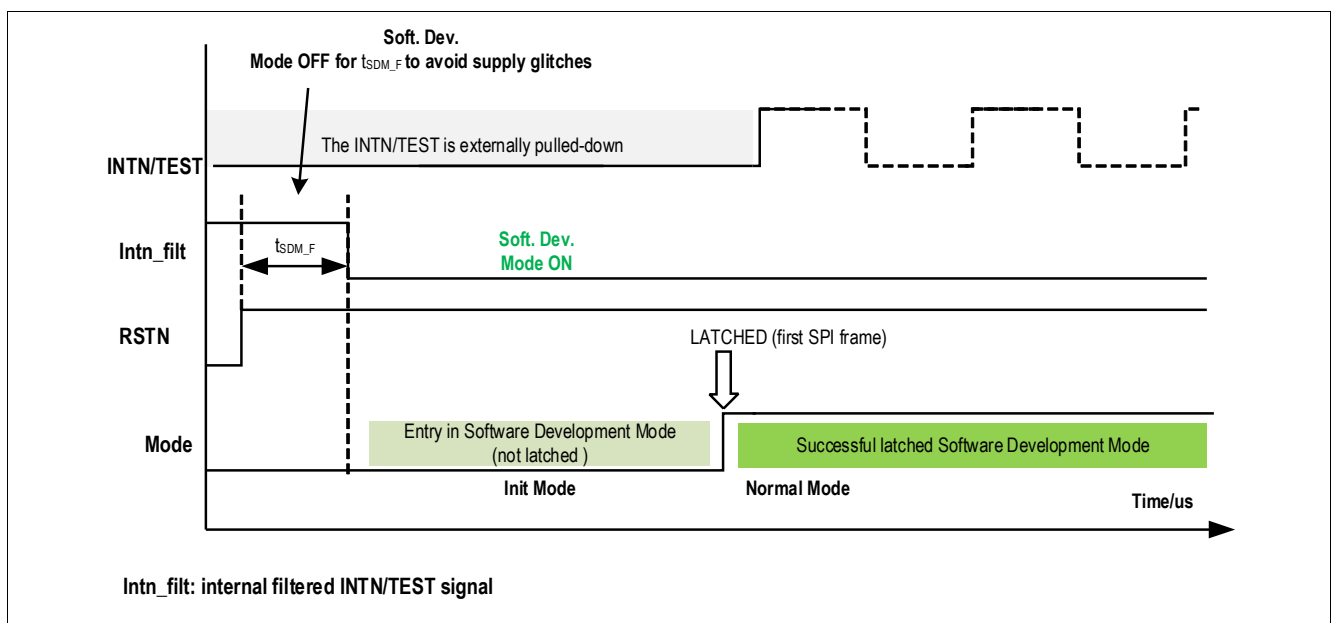

Figure 3 Software Development Mode Selection Timing

Intn_filt is a filtered signal from INTN/TEST, with the filter time t_{SMD_F} (P_11.2.7). Intn_filt starts (at the rising edge if RSNT) with the value 1.

System Features

Note: If during monitoring the INTN/TEST pin for Software Development Mode entry, the device changes the mode without SPI command, the device will not enter/stay in Software Development Mode.

CRC configuration detail

The CRC is configured using the following scheme:

- Pull-down on PWM1/CRC enable the CRC.
- No external components on PWM1/CRC disables the CRC.

In order to configure the CRC, the follow conditions have to be full filled:

- Init Mode (from power-up) or Restart Mode
- $VCC1 > V_{rtx}$
- **POR**=1
- **RSTN** = LOW

The configuration selection is done during the reset delay time t_{RD1} with a continuous filter time of t_{CFG_F} and the configuration (depending on the voltage level at PWM1/CRC) is latched at the rising edge of RSTN.

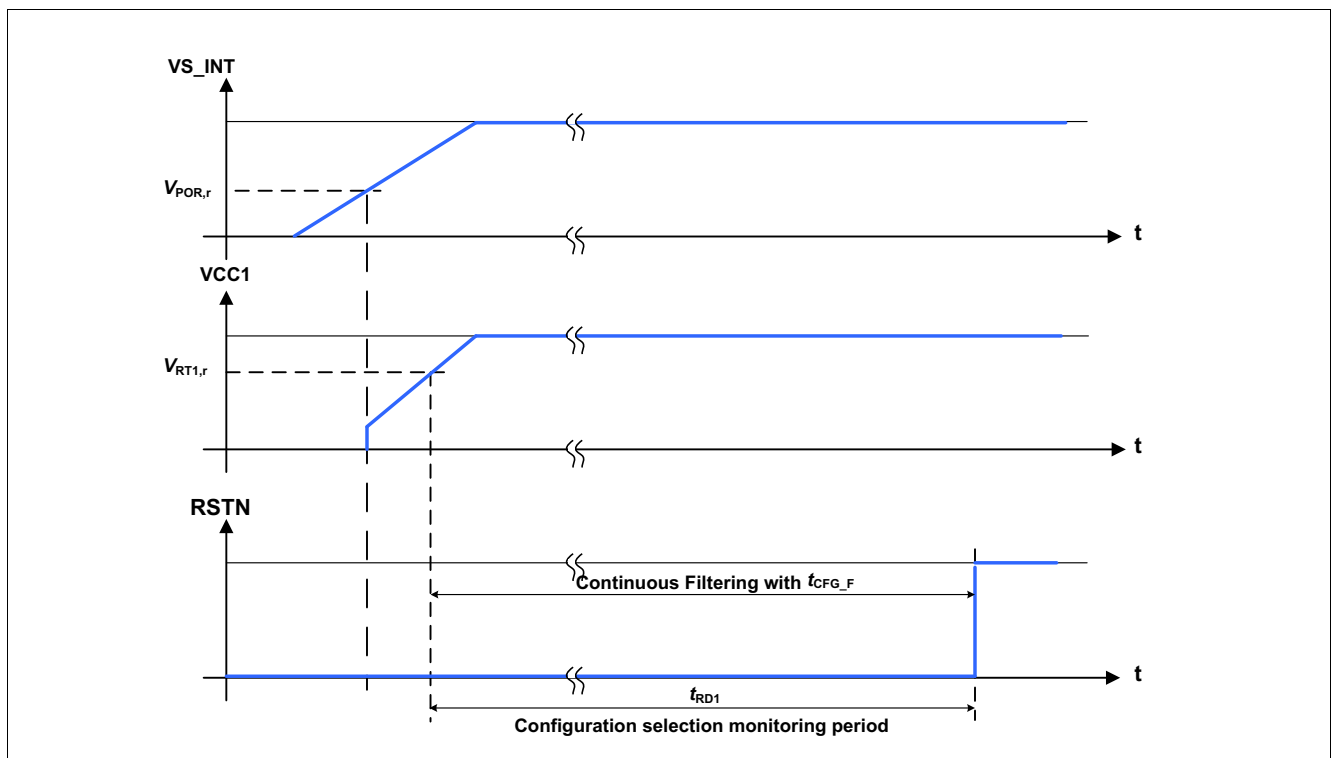

Figure 4 CRC configuration Selection Timing Diagram at the device power-up.

In case of mismatch between CRC setting between the device and μC (**CRC_STAT**), the device can accept two recovery SPI commands (static patterns).

The pattern 67AA AA0E_H (addr + rw_bit = 67 ; data = AAAA ; CRC = 0E) enables the CRC.

The pattern E7AA AAC3_H (addr + rw_bit = E7 ; data = AAAA ; CRC = C3) disables the CRC.

The patterns shall be send only in Normal Mode.

For additional details about the CRC setting and configuration, refer also to **Chapter 13.3.1**.

System Features

5.3 Block Description of State Machine

The state machine describes the different states of operation, the device may get into. The following figure shows the state machine flow diagram.

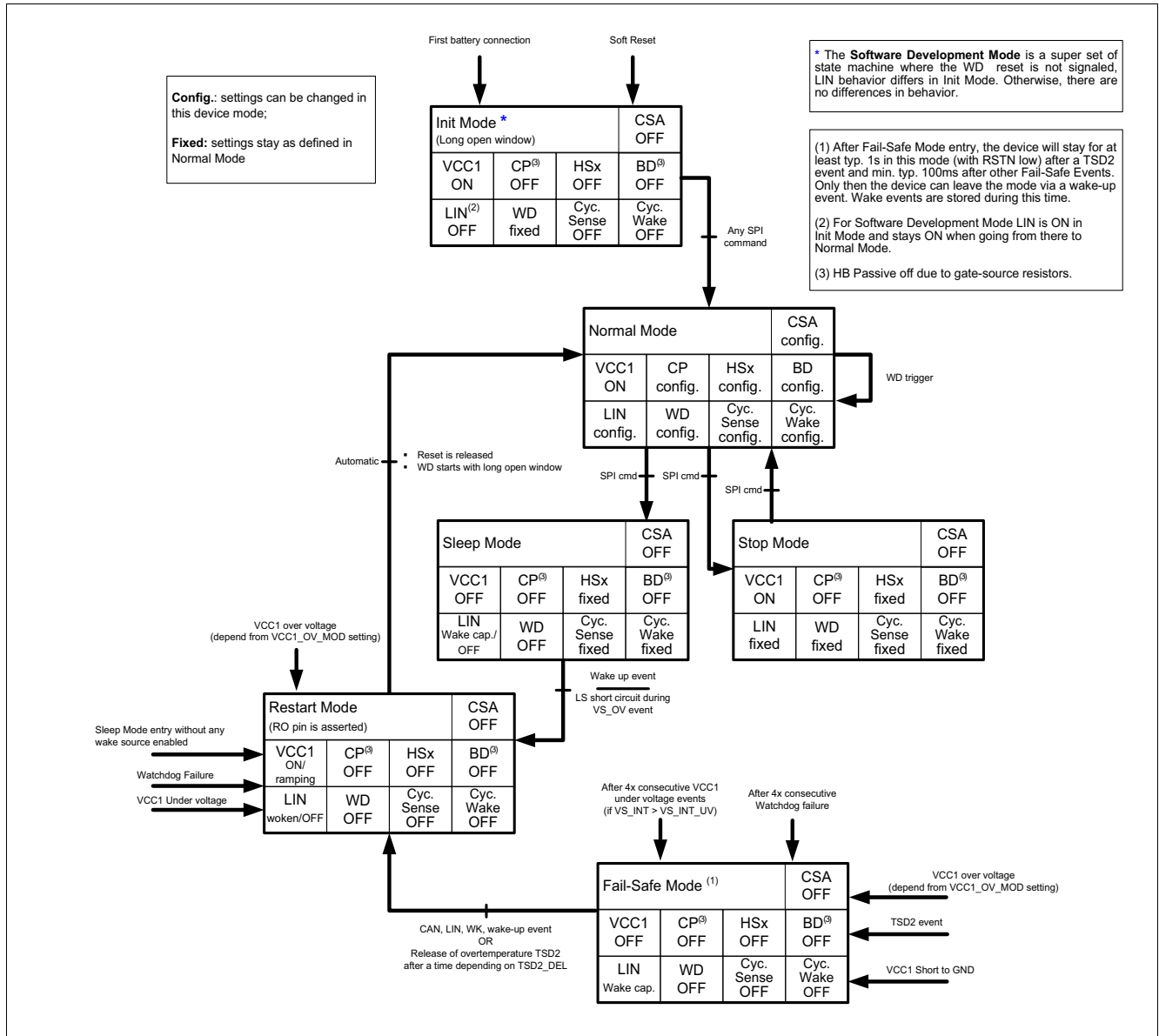

Figure 5 State Diagram showing the operating modes

Description:

- ON /OFF:= Indicate if the module is enabled or disabled either via SPI or from the device itself
- config:= Settings can be changed in this mode
- fixed:= Settings stay as defined in Normal Mode or Init Mode
- active/inactive:= Indicate if the device activates/deactivates one specific feature
- Wake capable:= Transceiver that is capable to detect one wake-up events
- woken:= Transceiver that has detected one wake-up event

System Features

5.4 State Machine Modes Description

5.4.1 Init Mode

The device starts up in Init Mode after crossing the power-on reset $V_{POR,r}$ threshold (see also [Chapter 12.3](#)) and the watchdog will start with a long open window (t_{LW}) after RSTN is released (High level).

In Init Mode, the device waits for the microcontroller to finish its startup and initialization sequence.

Init Mode (Long open window)			CSA OFF
VCC1 ON	CP OFF	HSx OFF	BD OFF
LIN OFF	WD fixed	Cyc. Sense OFF	Cyc. Wake OFF

Figure 6 Init Mode

Table 5 Init Mode Settings

Part/Function	Value	Description
VCC1	ON	• The VCC1 is ON
WD	fixed	• Watchdog is fixed and set with a long open window (t_{LW})
HSx	OFF	• All HSx are OFF
BD	OFF	• Bridge Drivers is OFF
CP	OFF	• Charge Pump is OFF
CSA	OFF	• Current Sense Amplifier is OFF
LIN	OFF	• LIN transceiver is OFF ¹⁾
Cyc Sense	OFF	• Cycle Sense is OFF
Cyc Wake	OFF	• Cycle Wake is OFF

1) Exception: The LIN transceiver is ON during Software Development Mode

5.4.2 Normal Mode

The Normal Mode is the standard operating mode for the device. The VCC1 is active and all features are configurable. Supervision and monitoring features are enabled.

System Features

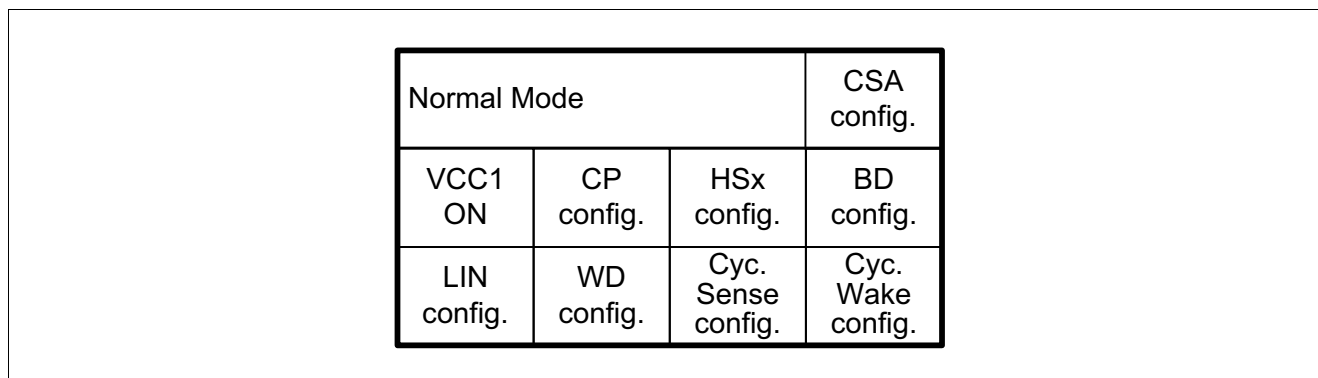

Figure 7 Normal Mode

Table 6 Normal Mode Settings

Part/Function	Value	Description
VCC1	ON	<ul style="list-style-type: none"> VCC1 is active
WD	config	<ul style="list-style-type: none"> Watchdog may be configured by SPI
HSx	config	<ul style="list-style-type: none"> The High Side Switches may be configured and switched ON or OFF by SPI
BD/CP	config	<ul style="list-style-type: none"> The Bridge Drivers and Charge Pump may be configured and switched ON or OFF by SPI
CSA	config	<ul style="list-style-type: none"> Current Sense Amplifier may be configurable and switched ON or OFF by SPI
LIN	config	<ul style="list-style-type: none"> LIN may be configurable and switched ON or OFF by SPI
Cyc. Sense	config	<ul style="list-style-type: none"> Cyclic sense may be configured with the HSx, WKx inputs and Timer1 or Timer2 or SYNC (WK4)
Cyc. Wake	config	<ul style="list-style-type: none"> Cyclic wake can be configured with the Timer1 or Timer 2

5.4.3 Stop Mode

The Stop Mode is the first level technique to reduce the overall current consumption by setting the voltage regulator VCC1 into a low-power mode.

Note: All settings have to be done before entering Stop Mode.

In Stop Mode any kind of SPI WRITE commands are ignored and the **SPI_FAIL** bit is set, except for changing to Normal Mode, triggering a device Soft Reset, refreshing the watchdog as well as for reading and clearing the SPI status registers.

*Note: A wake-up event on , LIN, WKx, Low-Side short circuit detection in parking braking mode or overvoltage brake detection, could generate an interrupt on pin INTN (based on INTN masking configuration; refer to **Chapter 10**) however, no change of the device mode will occur.*

System Features

Stop Mode			CSA OFF
VCC1 ON	CP OFF	HSx fixed	BD OFF
LIN fixed	WD fixed	Cyc. Sense fixed	Cyc. Wake fixed

Figure 8 Stop Mode

Table 7 Stop Mode Settings

Part/Function	Value	Description
VCC1	ON	• VCC1 is ON
WD	fixed	• Watchdog is fixed as configured in Normal Mode
HSx	fixed	• HSx are fixed as configured in Normal Mode
BD/CP	OFF	• The Bridge Drivers and Charge Pump are OFF
CSA	OFF	• Current Sense Amplifier is OFF
LIN	fixed	• LIN fixed as configured in Normal Mode
Cyc. Sense	fixed	• Cyclic sense fixed as configured in Normal Mode
Cyc. Wake	fixed	• Cyclic wake is fixed as configured in Normal Mode

Note: In Stop Mode, it is possible to activate the Low-Side of Bridge Drivers (e.g. in case of parking braking mode or overvoltage brake detection). Refer to [Chapter 12.10](#) for additional details.

5.4.4 Sleep Mode

The Sleep Mode is the second level technique to reduce the overall current consumption to a minimum needed to react on wake-up events or for the device to perform autonomous actions (e.g. cyclic sense).

Note: All settings have to be done before entering Sleep Mode.

Sleep Mode			CSA OFF
VCC1 OFF	CP OFF	HSx fixed	BD OFF
LIN Wake cap./ OFF	WD OFF	Cyc. Sense fixed	Cyc. Wake fixed

Figure 9 Sleep Mode

System Features

Table 8 Sleep Mode Settings

Part/Function	Value	Description
VCC1	OFF	• VCC1 is OFF
WD	OFF	• Watchdog is OFF
HSx	fixed	• HSx are fixed as configured in Normal Mode
BD/CP	OFF	• The Bridge Drivers and Charge Pump are OFF
CSA	OFF	• Current Sense Amplifier is OFF
LIN	Wake Cap/ OFF	• LIN fixed as configured (Wake Capable or OFF)
Cyc. Sense	fixed	• Cyclic sense fixed as configured in Normal Mode
Cyc. Wake	fixed	• Cyclic wake is fixed

Note: In Sleep Mode, it is possible to activate the Low-Side's of Bridge Drivers (e.g. in case of parking braking mode or overvoltage braking). Refer to [Chapter 12.10](#) for additional details.

5.4.5 Restart Mode

The Restart Mode is a transition state where the RSNT pin is asserted.

<table border="1"> <tr> <td colspan="3">Restart Mode (RO pin is asserted)</td> <td>CSA OFF</td> </tr> <tr> <td>VCC1 ON/ ramping</td> <td>CP OFF</td> <td>HSx OFF</td> <td>BD OFF</td> </tr> <tr> <td>LIN woken/ OFF</td> <td>WD OFF</td> <td>Cyc. Sense OFF</td> <td>Cyc. Wake OFF</td> </tr> </table>				Restart Mode (RO pin is asserted)			CSA OFF	VCC1 ON/ ramping	CP OFF	HSx OFF	BD OFF	LIN woken/ OFF	WD OFF	Cyc. Sense OFF	Cyc. Wake OFF
Restart Mode (RO pin is asserted)			CSA OFF												
VCC1 ON/ ramping	CP OFF	HSx OFF	BD OFF												
LIN woken/ OFF	WD OFF	Cyc. Sense OFF	Cyc. Wake OFF												

Figure 10 Restart Mode

Table 9 Restart Mode Settings

Part/Function	Value	Description
VCC1	ON/ ramping	• VCC1 is ON or ramping up
WD	OFF	• WD will be disabled if it was activated before
HSx	OFF	• HSx will be disabled if it was activated before
BD/CP	OFF	• The Bridge Drivers and Charge Pump are OFF
CSA	OFF	• Current Sense Amplifier is OFF
LIN	Woken/ wake capable/ OFF	• LIN may woken (in case of wake-up event on the Bus) or wake capable or OFF

System Features

Table 9 Restart Mode Settings (cont'd)

Part/Function	Value	Description
Cyc. Sense	OFF	• Cyclic sense will be disabled if it was activated before
Cyc. Wake	OFF	• Cyclic wake will be disabled if it was activated before

5.4.6 Fail-Safe Mode

The purpose of this mode is to bring the system in a safe status after a failure condition by turning OFF the VCC1 supply and powering off the microcontroller. After a wake event the system is then able to restart again.

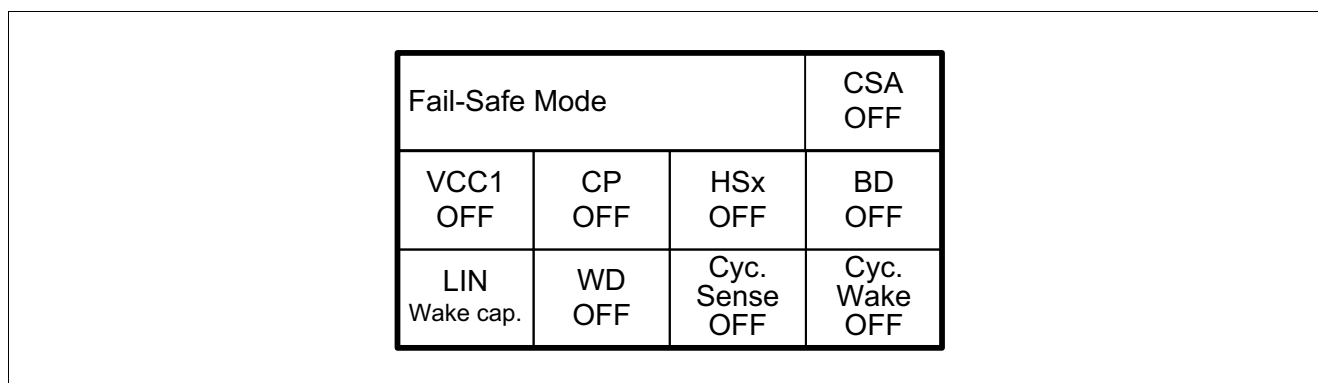

Figure 11 Fail-Safe Mode

Table 10 Fail-Safe Mode Settings

Part/Function	Value	Description
VCC1	OFF	• VCC1 is switched OFF
WD	OFF	• WD is switched OFF
HSx	OFF	• HSx are switched OFF
BD/CP	OFF	• The Bridge Drivers and Charge Pump are OFF
CSA	OFF	• Current Sense Amplifier is OFF
LIN	Wake Cap	• LIN is forced to be Wake capable
Cyc. Sense	OFF	• Cyclic sense is switched OFF
Cyc. Wake	OFF	• Cyclic wake is switched OFF

Note

- In Fail-Safe Mode, the default wake sources , LIN and WKx (if configured as wake inputs) are activated automatically and all wake event bits will be cleared.
- The Fail-Safe Mode will be maintained until a wake event on the default wake sources occurs. To avoid any fast toggling behavior a filter time of typ. 100ms ($t_{FS,min}$) is implemented. Wake events during this time will be stored and will automatically lead to entering Restart Mode after the filter time.
 In case of an VCC1 overtemperature shutdown (TSD2) the Restart Mode will be reached automatically after a filter time of typ. 1s (t_{TSD2}) without the need of a wake event once the device temperature has fallen below the TSD2 threshold.
- The parking braking mode is automatically disabled in Fail-Safe Mode.

System Features

5.4.7 Software Development Mode

The Software Development Mode is a dedicated device configuration especially useful for software development.

Compared to the default device user mode operation, this mode is a super set of the state machine. The device will start also in Init Mode and it is possible to use all the modes and functions with following differences:

- Restart Mode or Fail-Safe Mode (depending on the configuration) is not reached due to watchdog failure but the other reasons to enter these modes are still valid.
- , LIN default value in Init Mode and entering Normal Mode from Init Mode is ON instead of OFF.

Table 11 Normal Mode Settings (Software Development Mode active)

Part/Function	Default State	Description
VCC1	ON	• VCC1 is active
WD	ON	• WD is on, but will not trigger transition to Fail-Safe Mode or Restart Mode
HSx	OFF	• The High Side Switches may be configured and switched ON or OFF by SPI
BD/CP	OFF	• The Bridge Drivers and Charge Pump may be configured and switched ON or OFF by SPI
LIN	ON	• LIN may be configurable and switched ON or OFF by SPI
Cyc. Sense	OFF	• Can be configured
Cyc. Wake	OFF	• Can be configured

Software Development Mode entry

For timing and configuration details, refer to [Chapter 5.2](#).

Note

- After Init Mode, the pull-up is released as the INTN/TEST pin acts as output then to drive the INTN signal.
- If the device enters Fail-Safe Mode due to VCC1 short circuit to GND during the Init Mode, the Software Development Mode will not be entered and can only be reached at the next power-up of the device after the VCC1 short circuit is removed.
- The absolute maximum ratings of the pin INTN must be observed. To increase the robustness of this pin during debugging or programming a series resistor between INTN and the connector can be added.

Watchdog in Software Development Mode

The Watchdog is enabled in Software Development Mode as default state. One INTN event is generated due to wrong watchdog trigger.

It is possible to deactivate the integrated Watchdog module using the [WD_SDM_DISABLE](#) bit. After disabling the Watchdog, no INTN events are generated and the [WD_FAIL](#) bit will also not be set anymore in case of a trigger failure. It is also possible only to mask / unmask the INTN event of the WD in Software Development Mode by using the bit [WD_SDM](#). In case of unmasking, a WD trigger fail will only lead to [WD_FAIL](#) bit set.

5.5 Transition Between States

This chapter describes the transition between the modes triggered by power-up, SPI commands or wake-up events.

System Features

5.5.1 Transition into Init Mode

The device goes into Init Mode in case of a power-up or after sending a soft-reset in Normal or Stop Mode.

Prerequisites:

- Power OFF
- Device in Normal Mode or Stop Mode with follow conditions:
 - $VSINT > VPOR,r$
 - RSTN High

Triggering Events:

- A Soft Reset command (**MODE** = '11'). All SPI registers will be changed to their respective Soft Reset values.

Note

- In case of Soft Reset command, a hardware RSTN event can be generated depending on the configuration. An external Reset will be generated in case of **SOFT_RESET_RO** = 0_B. In case of **SOFT_RESET_RO** = 1_B, no RSTN hardware event is generated in case of Soft Reset.
- At power-up, the SPI bit **VCC1_UV** will not be set as long as VCC1 is below the VRT,x threshold and if VSINT is below the VSINT,UV threshold. The RSTN pin will be kept LOW as long as VCC1 is below the selected VRT1,r threshold. The reset delay counter will start after VRT1,r threshold is reached. After the first threshold crossing of $VCC1 > V_{RT1,R}$ and RSTN transition from low to high, all subsequent undervoltage events will lead to Restart Mode.
- Wake events are ignored during Init Mode and will be lost.
- The bit **VSINT_UV** will only be updated in Init Mode once RSTN resumes a high level.

5.5.2 Init Mode -> Normal Mode

This transition moves the device in the mode where all configurations are accessible via SPI command.

Prerequisites:

- $VSINT > VPOR,r$
- Init Mode
- RSTN High

Triggering Events:

- Any valid SPI command (from SPI protocol point of view) will bring the device to Normal Mode (i.e. any register can be written, cleared and read) during the long open window where the watchdog has to be triggered (refer also [Chapter 13.2](#)). The CRC is not taken into account for this transition.
- For example:
 - A SPI Sleep Mode command will still bring the device into Normal Mode. However, as this is an invalid state transition, the SPI bit **SPI_FAIL** is set.
 - Any invalid SPI command (from content point of view) will still bring the device into Normal Mode. The SPI bit **SPI_FAIL** is set.

Note

- It is recommended to use the first SPI command to trigger and to configure the watchdog.

5.5.3 Normal Mode -> Stop Mode

This transition is intended as first measure to reduce the current consumption. All the device features needed in Stop Mode shall be configured in Normal Mode.

System Features

Prerequisites:

- VCC1>Vrtx
- Device in Normal Mode

Triggering Events:

- State transition is only initiated by specific SPI command.

Note

- An interrupt is triggered on the pin INTN when Stop Mode is entered and not all wake source signalization flags were cleared.
- If high-side switches are kept enabled during Stop Mode, then the device current consumption will increase.
- It is not possible to switch directly from Stop Mode to Sleep Mode. Doing so will also set the **SPI_FAIL** flag and will bring the device into Restart Mode.

5.5.4 Normal Mode -> Sleep Mode

This transition is intended to reduce as much as possible the current consumption keeping active only wake-up sources. All wake-up sources configurations shall be done in Normal Mode.

Prerequisites:

- VCC1>Vrtx
- Device in Normal Mode
- All wake source signalization flags were cleared (including the LSxDISOV_BRK bit)
- At least one wake-up source activated

Triggering Events:

- State transition is only initiated by specific SPI command.

Note

- If the HSx outputs are kept enabled during Sleep Mode, then the device current consumption will increase (see [Chapter 4.4](#)).
- The Cyclic Sense function will not work properly anymore in case of a failure event (e.g. overcurrent, over temperature, reset) because the configured HSx and Timers will be disabled.
- If **VCC1_UV** or **VCC1_OV** (with Config to go to Restart Mode) occurs at the border of the Sleep Mode entry: The device will go immediately into Restart Mode.
- If **TS2** or **VCC1_OV** (with Config to go to Fail-Safe Mode) occurs at the border of the Sleep Mode entry: The device will enter immediately Fail-Safe Mode.
- As soon as the Sleep Mode command is sent, the Reset will go low.
- It is not possible to switch all wake sources off in Sleep Mode. Doing so will set the **SPI_FAIL** flag and will bring the device into Restart Mode.

5.5.5 Stop Mode -> Normal Mode

This transition is intended to set the device in Normal Mode where all the device integrated features are available and configurable.

Prerequisites:

- VCC1>Vrtx

System Features

- Device in Stop Mode

Triggering Events:

- State transition is only initiated by SPI command.

Note

- None

5.5.6 Sleep Mode -> Restart Mode

This transition is the consequence of a detection of wake-up event by the device. This transition is used to ramp up VCC1 after a wake in a defined way.

Prerequisites:

- Device in Sleep Mode
- At least one wake-up source active

Triggering Events:

- A wake-up event on , LIN, WKx, Cyclic Sense, Cyclic Wake.
- Bridge driver low-side short circuit detected during overvoltage braking or in parking braking mode.

Note

- It is not possible to switch off all wake sources in Sleep Mode. Doing so will set the **SPI_FAIL** flag and will bring the device into Restart Mode.
- RSTN is pulled low during Restart Mode.
- The Restart Mode entry is signalled in the SPI register **DEV_STAT**.
- The wake-up events are flagged in **WK_STAT** register or **DSOV** register.

5.5.7 Restart Mode -> Normal Mode

From Restart Mode, the device goes automatically to Normal Mode.

Prerequisites:

- Device in Sleep Mode or Fail-Safe Mode

Triggering Events:

- Automatic
- Reset is released

Note

- The watchdog timer will start with a long open window starting from the moment of the rising edge of RSTN and the watchdog period setting in the register **WD_CTRL** will be changed to the respective default value.

5.5.8 Fail-Safe Mode -> Restart Mode

This transition is similar to device from Sleep Mode to Restart Mode and consequence of a detection of wake-up event by the device. This transition is used to ramp up VCC1 after a wake in a defined way.

Prerequisites:

- Device in Fail-Safe Mode

Triggering Events:

System Features

- A wake-up event on , LIN, WKx, TSD2 (released over temperature TDS2 after t_{TSD2}).
- Bridge Driver Low Side short circuit detected during VS/VSINT overvoltage braking mode or in parking braking mode.

Note: After leaving Fail-Safe Mode, the **FAILURE** bit in **DEV_STAT** register is set.

5.6 Reaction on Detected Faults

The device can react at some critical events either signalling the specific failure or changing the device mode. The chapter describes actions taken from the device in case of critical events in particular related the device mode change.

5.6.1 Stay in Current State

The following failures will not trigger any device mode changes, but will indicate the failures by an INTN event (depending from the Interrupt Masking) and in dedicated status registers:

- Failures on LIN
- Failures in Bridge Driver and/or Charge Pump
- Failures on HSx

5.6.2 Transition into Restart Mode

The Restart Mode can be entered in case of failure as shown in following figure.

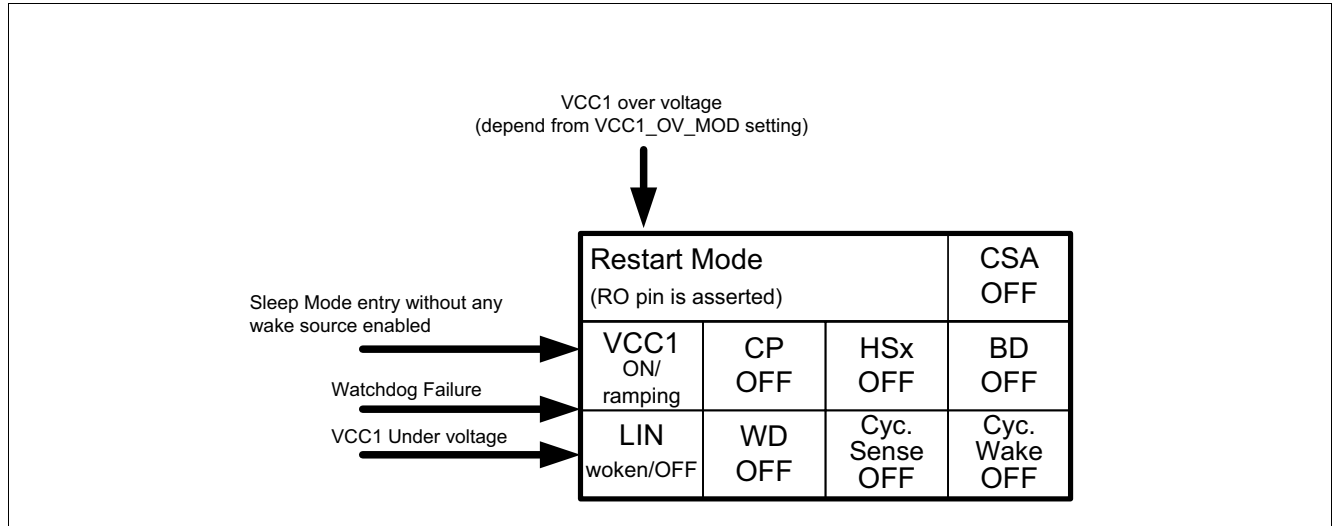

Figure 12 Move into Restart Mode

Prerequisites

- In case of wake-up event from Sleep Mode or Fail Safe Mode
- In case of Normal Mode
- In case of Stop Mode

Trigger Events

- VCC1 Undervoltage in case of Normal Mode or Stop Mode.
- Watchdog trigger failure in case of Normal Mode or Stop Mode.
- VCC1 Overvoltage (based on **VCC1_OV_MOD**) in case of Normal Mode or Stop Mode.

System Features

- Sleep Mode entry without any wake-up sources enabled in Normal Mode or Stop Mode.

Note

- None

System Features

5.6.3 Transition into Fail-Safe Mode

The Fail-Safe Mode can be entered in case of critical event as shown in the following figure.

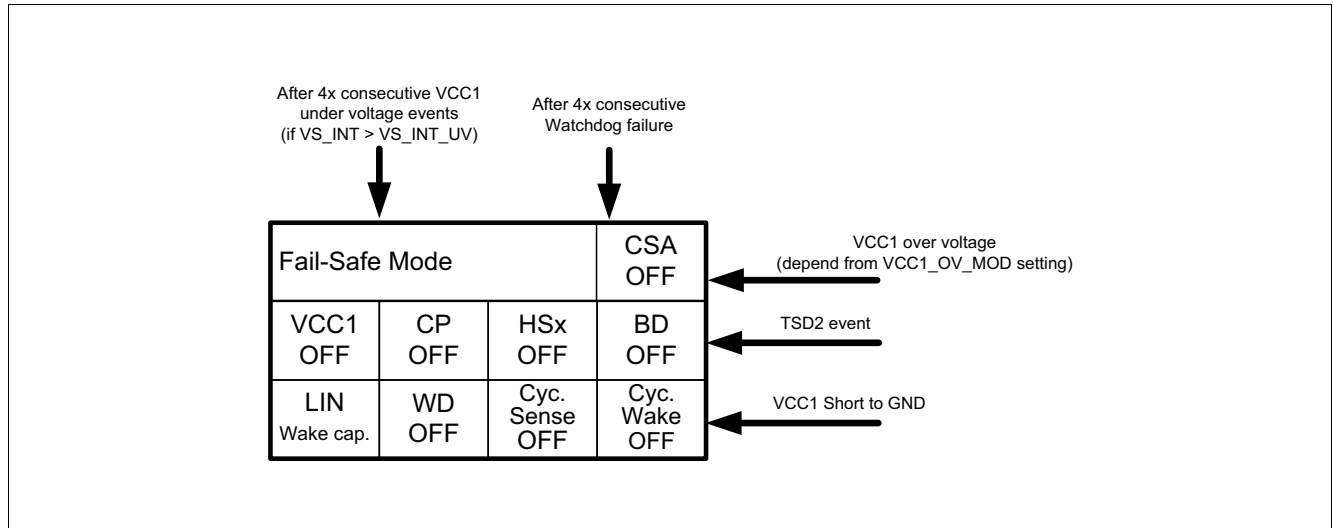

Figure 13 Move into Fail-Safe Mode

Prerequisites:

- Critical events on VCC1
- Watchdog trigger failures

Trigger Events:

- Device thermal shutdown (TSD2) (see also [Chapter 12.9.3](#)).
- VCC1 is shorted to GND (see also [Chapter 12.8](#)).
- VCC1 over voltage (based on [VCC1_OV_MOD](#)).
- 4 consecutive Watchdog trigger failure.
- 4 consecutive VCC1 under voltage events.

5.7 Wake Features

Following wake sources are implemented in the device:

- Static Sense: WKx inputs are permanently active as wake sources.
- Cyclic Sense: WKx inputs only active during on-time of cyclic sense period. Internal timers are activating HSx during on-time for sensing the WKx inputs.
- Cyclic Wake: wake controlled by internal timers, wake inputs are not used for cyclic wake.
- LIN wake: Wake-up via Bus messages (refer to [Chapter 8.2.4](#)).

Note:

Differences of 'cyclic sense' and 'cyclic wake':

In both cases a timer is active. With 'cyclic sense' one of the high-side drivers is switched on periodically and supplies some external circuits connected to the WK inputs. For the design, this means that the WK input states are only sampled at the end of the selected HS on-phase which is set by the corresponding SPI settings for GPIO HS and the timer. 'Cyclic wake' means that the timer is a wake source and thus generates periodic interrupts as long as it is enabled.

System Features

5.7.1 Cyclic Sense

The cyclic sense feature is intended to reduce the quiescent current of the device and the application. In the cyclic sense configuration, one high-side driver is switched on periodically controlled by **TIMER_CTRL** or WK4/SYNC pin. One high-side driver supplies external circuitries e.g. switches and/or resistor arrays, which are connected to one wake input WKx (see **Figure 14**). Any edge change of the WKx input signal during the on-time of the cyclic sense period causes a wake event. Depending on the device mode, either the INTN is pulled low (Normal Mode and Stop Mode) or the device is woken enabling the VCC1 (after Sleep Mode).

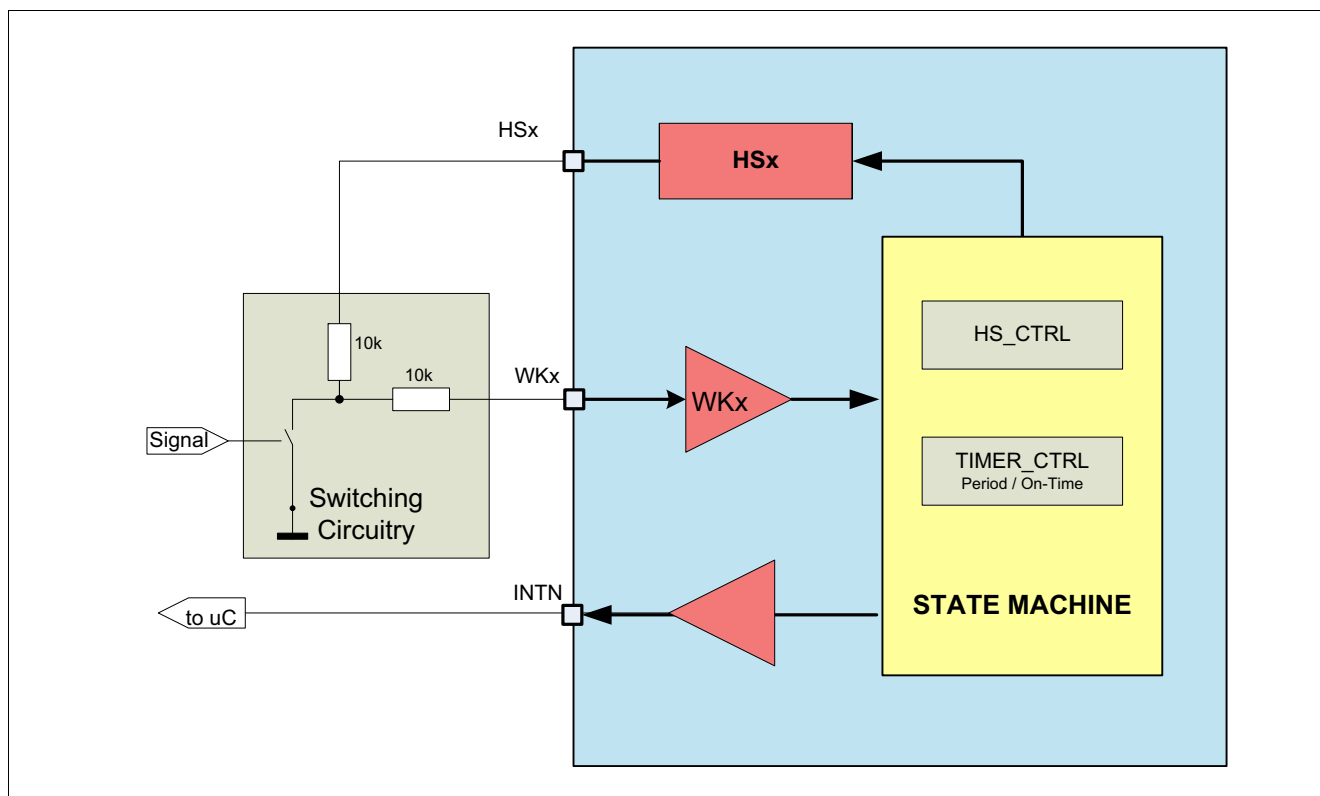

Figure 14 Cyclic Sense Working Principle

5.7.1.1 Configuration and Operation of Cyclic Sense

The correct sequence to configure the cyclic sense is shown in **Figure 15**. All the configurations have to be performed before the on-time is set in the **TIMER_CTRL** registers. The settings “OFF / LOW” and “OFF / HIGH” define the voltage level of the respective HS driver before the start of the cyclic sense. The intention of this selection is to avoid an unintentional wake due to a voltage level change at the start of the cyclic sense.

Cyclic Sense will start as soon as the respective on-time has been selected independently from the assignment of the HS and filter configuration. The correct configuration sequence is as follows:

- Configure the initial level.
- Mapping of a Timer to the respective HSx outputs.
- Configuring the respective filter timing and WK pins.
- Configuring the timer period and on-time.

System Features

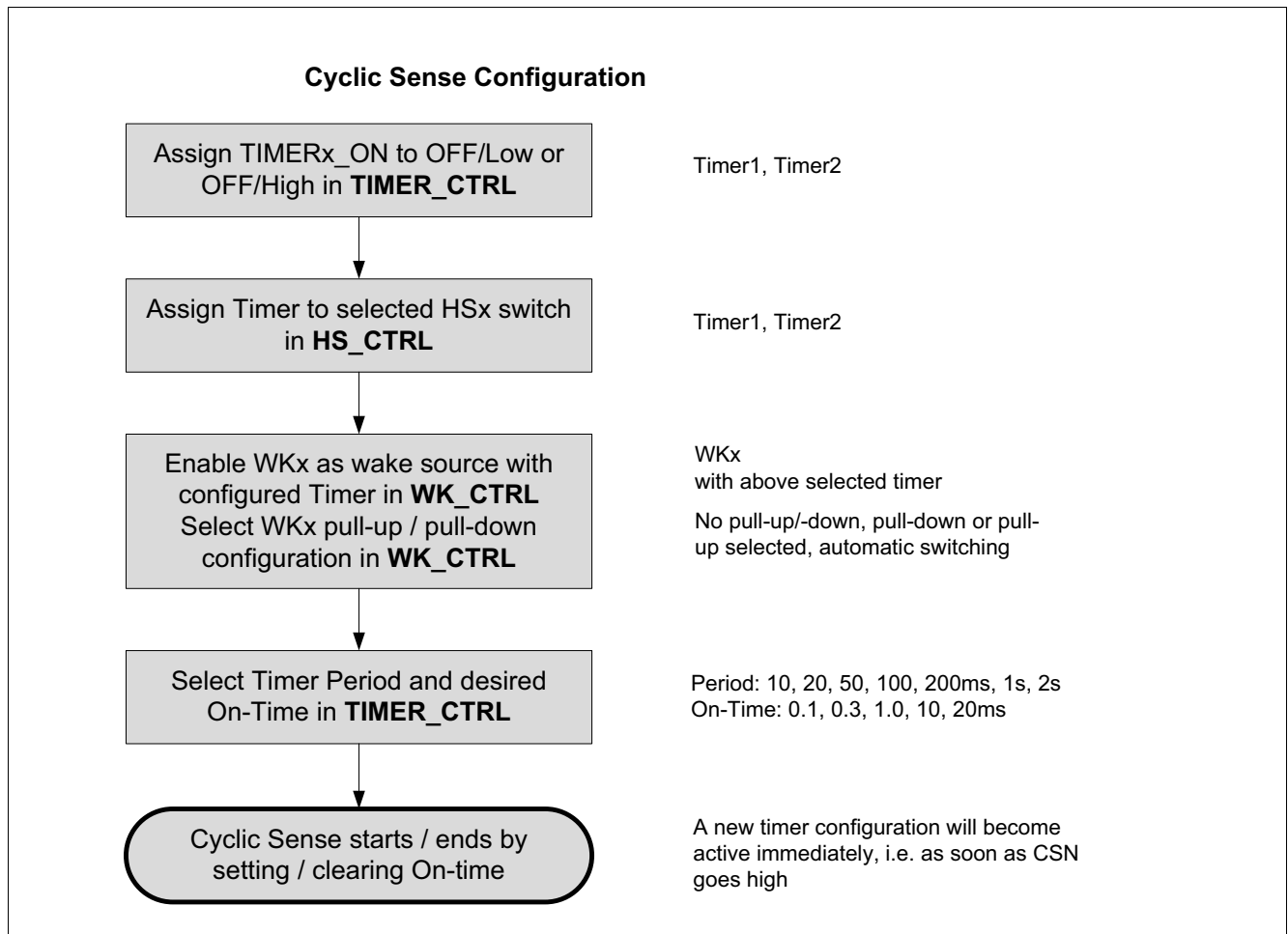

Figure 15 Cyclic Sense: Configuration and Sequence

System Features

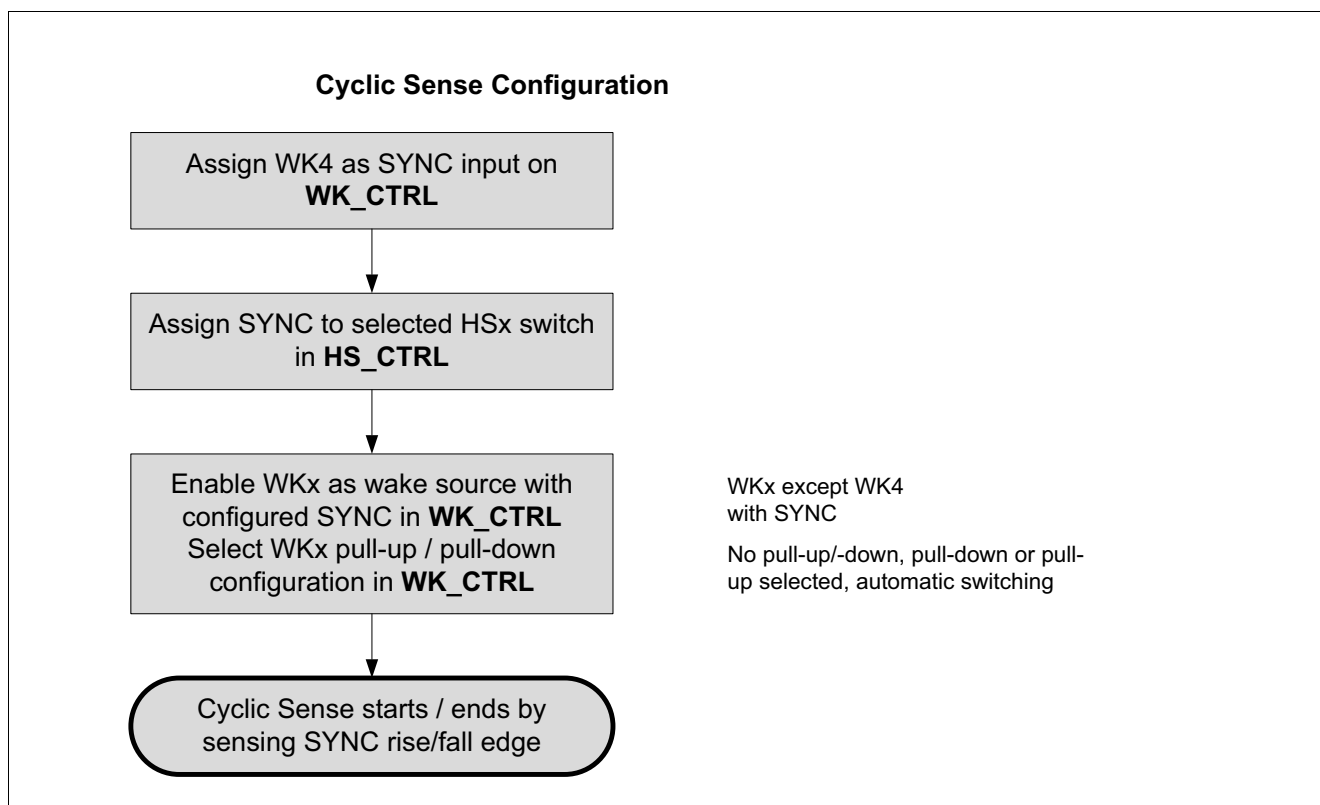

Figure 16 Cyclic Sense: Configuration and Sequence in case of SYNC usage

Note

- All configurations of period and on-time can be selected. However, recommended on-times for cyclic sense are 0.1ms, 0.3ms and 1ms for quiescent current saving reasons. The **SPI_FAIL** will be set if the on-time is longer than the period.
- If the sequence is not ensured before entering Sleep Mode, then the cyclic sense function might not work properly, e.g. an interrupt could be missed or an unintentional interrupt could be triggered. However, if cyclic sense is the only wake source and it is not configured properly, then Restart Mode will be entered immediately because no valid wake source was set.
- During the HSx on phase in cyclic-sensing, the WKx level is sampled only once (one sample point). In case, a level change will appear during HSx on phase, but before the sampling, as the sampling will happen at the end of the on time, the level change will not be detected and has to wait for the next sensing-cycle.

A wake event caused by cyclic-sensing will also set the corresponding bit WKx_WU.

During Cyclic Sense, **WK_LVL_STAT** is updated only with the sampled voltage levels of the WKx pin in Normal Mode or Stop Mode.

The functionality of the sampling and different scenarios are depicted in **Figure 17** to **Figure 19**. The behavior in Stop Mode and Sleep Mode is identical except that in Normal Mode and Stop Mode INTN will be triggered to signal a change of WKx input level and in Sleep Mode, VCC1 will power-up instead. A wake event will be triggered regardless if the bit WKx_WU is already set.

System Features

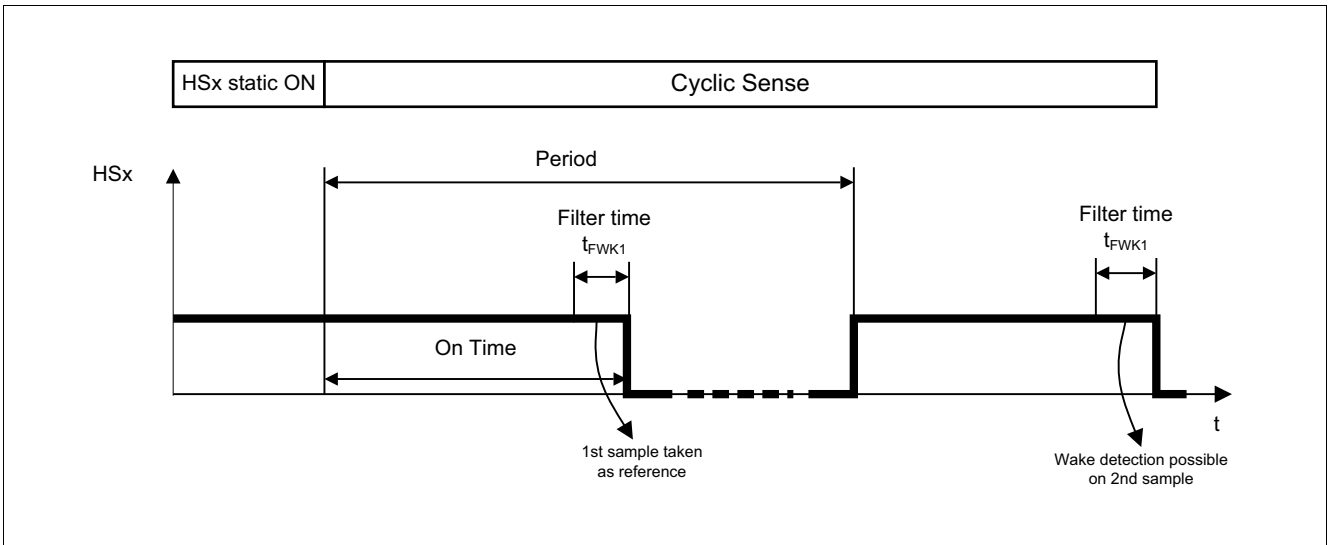

Figure 17 Cyclic Sense Timing

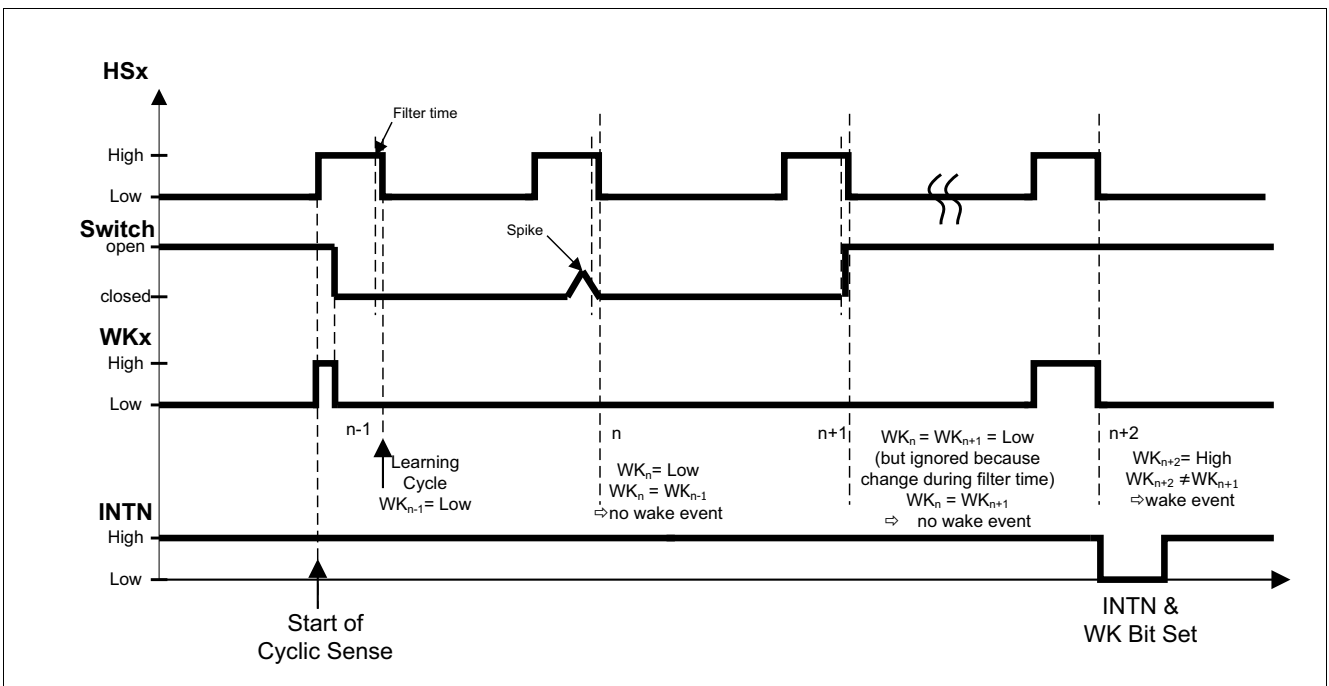

Figure 18 Cyclic Sense Example Timing for Stop Mode, HSx starts LOW, GND based WKx input

System Features

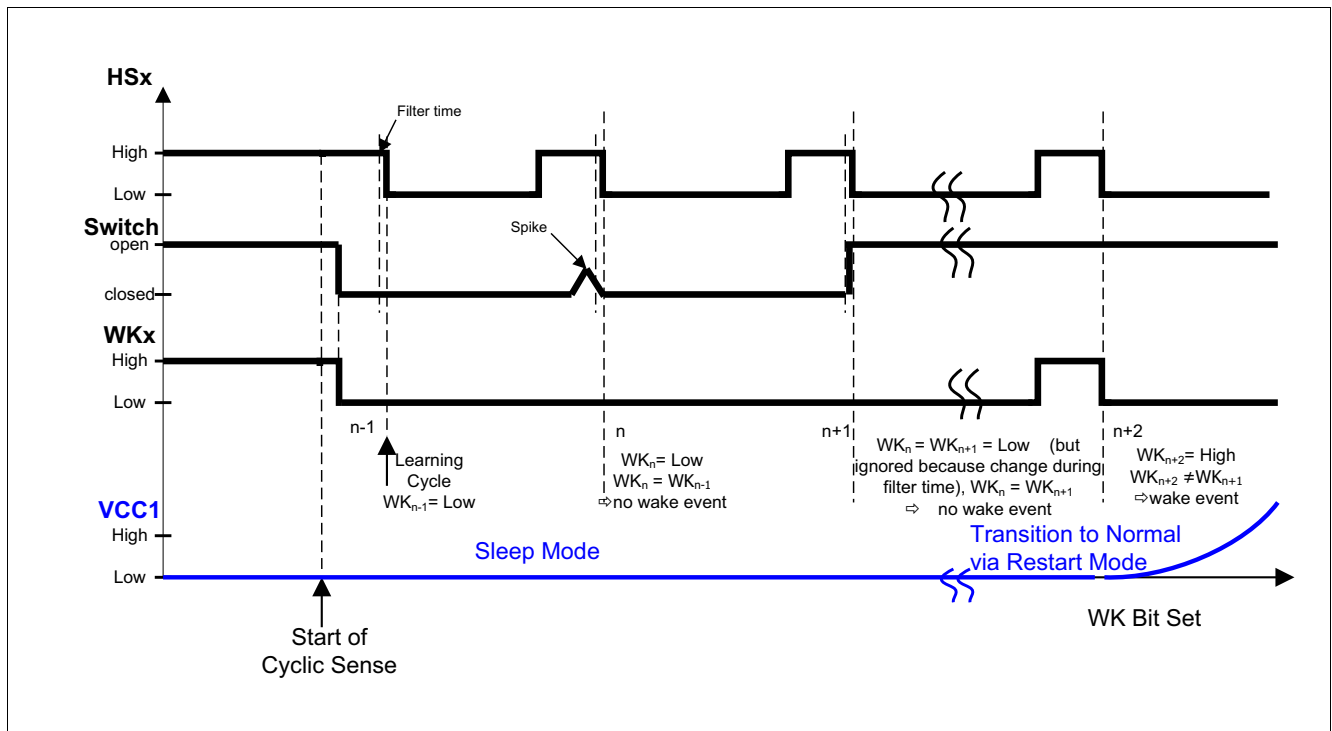

Figure 19 Cyclic Sense Example Timing for Sleep Mode, HSx starts with ON, GND based WKx input

The cyclic sense function will be disabled in case of following conditions:

- in case Fail-Safe Mode is entered, the HSx switch will be disabled and the WKx pin will be changed to static sensing. An unintended wake-up event could be triggered when the WKx input is changed to static sensing.
- In Normal Mode, Stop Mode, or Sleep Mode in case of an overcurrent, or overtemperature, or under- or overvoltage event, the respective HS switch will be disabled.

5.7.1.2 Cyclic Sense in Low-power Mode

If cyclic sense is intended for Stop Mode or Sleep Mode, it is necessary to activate cyclic sense in Normal Mode before going to the low-power mode. A wake event due to cyclic sense will set the bit WKx_WU. In Stop Mode a wake event will trigger an interrupt, in Sleep Mode the wake event will send the device via Restart Mode to Normal Mode.

Before returning to Sleep Mode, the wake status registers **WK_STAT** and **DSOV** must be cleared. Trying to go to Sleep Mode with uncleared wake flags will lead to a direct wake-up from Sleep Mode by going via Restart Mode to Normal Mode and triggering of RSTN.

5.7.2 Cyclic Wake

For the cyclic wake feature one timer is configured as internal wake-up source and will periodically trigger an interrupt on INTN in Normal Mode and Stop Mode. During Sleep Mode, the timer triggers and wakes up the device again. The device enters via Restart Mode the Normal Mode.

The correct sequence to configure the cyclic wake is shown in **Figure 20**. The sequence is as follows:

System Features

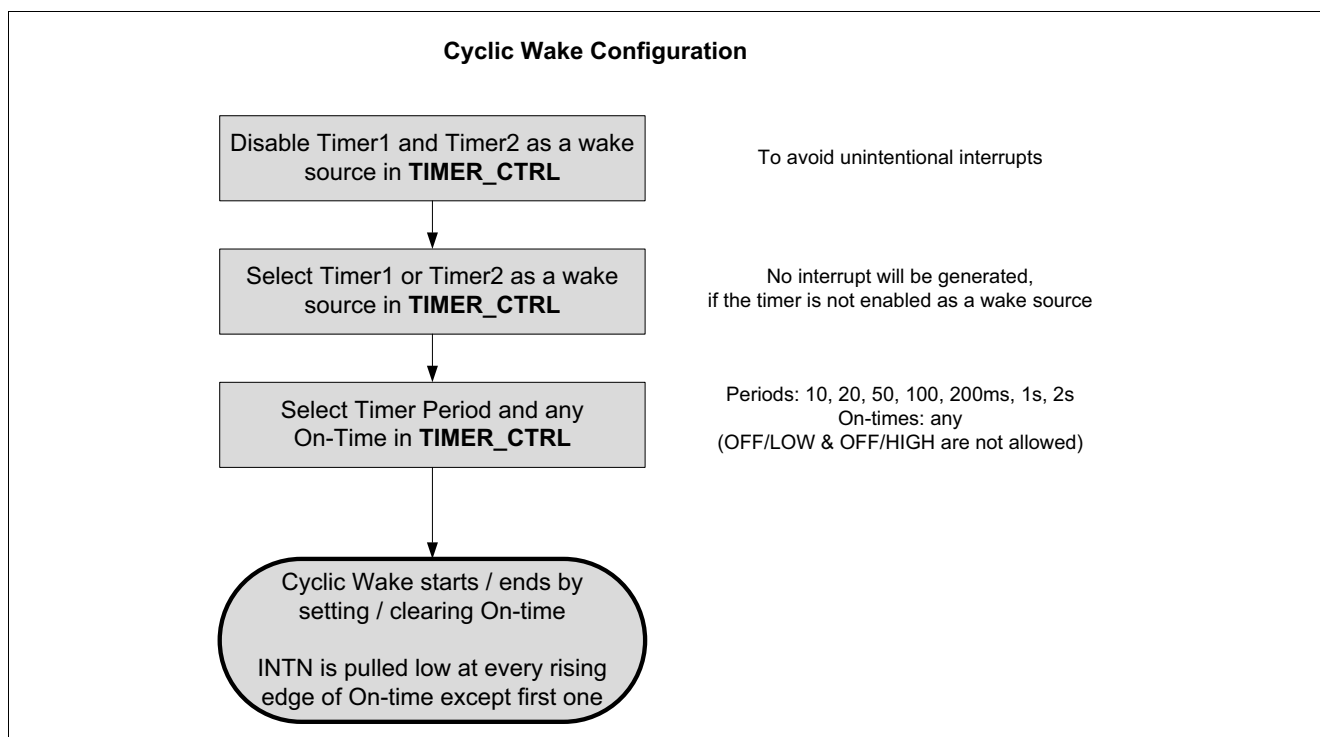

Figure 20 Cyclic Wake: Configuration and Sequence

Note: The on-time is only used to enable the cyclic wake function regardless of the value of the on time, i.e. the on time value has no meaning to the cyclic wake function as long as it is not '000' or '110' or '111'.

As in cyclic sense, the cyclic wake function will start as soon as the on-time is configured. An interrupt is generated for every start of the on-time except for the very first time when the timer is started.

5.7.3 Internal Timers

Two integrated timers can be used to control the below features:

- Cyclic Wake, i.e. to wake up the microcontroller periodically in Normal Mode, Stop Mode and Sleep Mode.
- Cyclic Sense, i.e. to perform cyclic sensing using the wake input WKx and the HSx by mapping the timer accordingly via the **HS_CTRL** register.

5.8 VS Supply Multiplexing

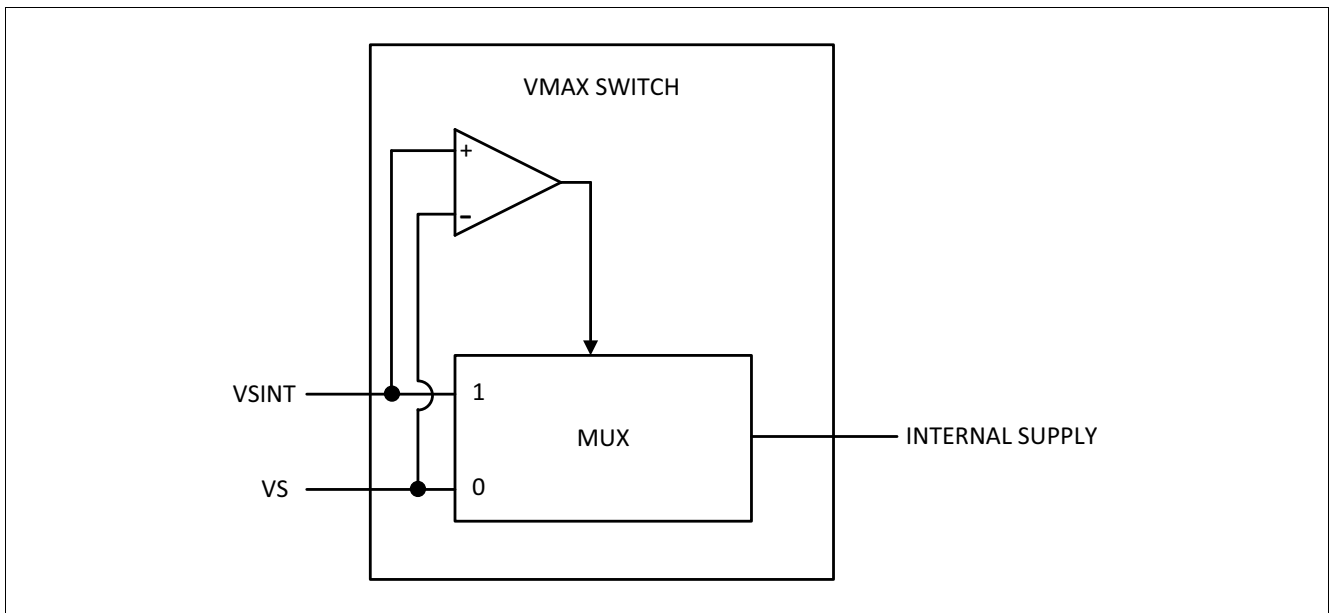

Figure 21 VS Supply Multiplexing

The internal supply voltage is multiplexed from VSINT and VS, choosing continuously the larger of both. In case of transient low VBAT, the buffered supply voltage takes over the internal supply, avoiding loss of power.

Note: Only the internal digital logic of the device is supplied by the VMAX SWITCH. In case of a power loss of either VS or VSINT, the internal register values will not be lost.

6 Voltage Regulator 1

6.1 Block Description

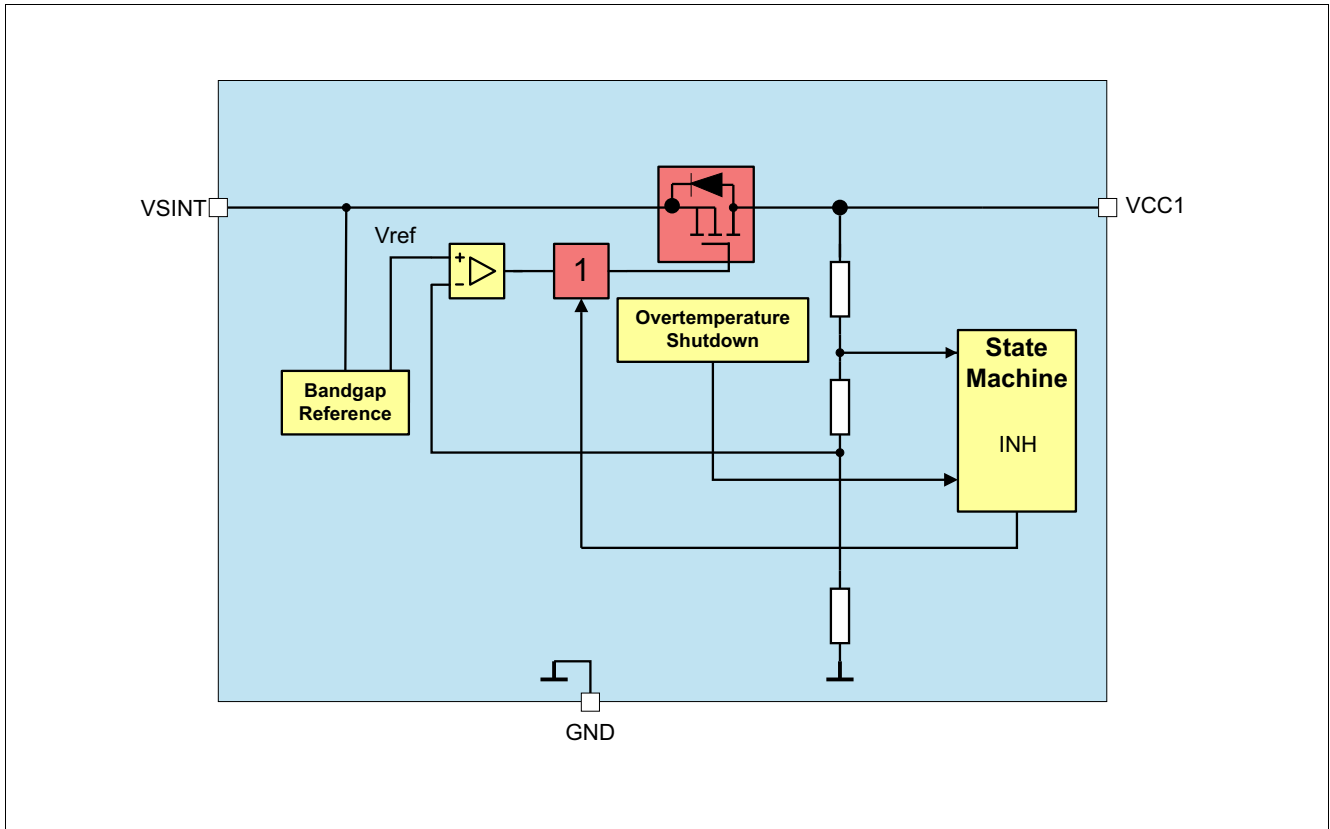

Figure 22 Module Block Diagram

Functional Features

- 5 V low-drop voltage regulator.
- Undervoltage monitoring with adjustable reset level and VCC1 undervoltage prewarning (refer to [Chapter 12.7](#) and [Chapter 12.8](#) for more information).
- Short circuit detection and switch off with undervoltage fail threshold, device enters Fail-Safe Mode.
- Effective capacitance must be $\geq 1 \mu\text{F}$ at nominal voltage output for stability. A $2.2 \mu\text{F}$ ceramic capacitor (MLCC) is recommended for best transient response.
- Output current capability up to $I_{VCC1,lim}$.

Voltage Regulator 1

6.2 Functional Description

The Voltage Regulator 1 (=VCC1) is “ON” in Normal Mode and Stop Mode and is disabled in Sleep Mode and in Fail-Safe Mode. The regulator can provide an output current up to $I_{VCC1,lim}$.

For low-quiescent current reasons, the output voltage tolerance is decreased in Stop Mode because only the less accurate low-power mode regulator will be active for small loads. If the load current on VCC1 exceeds the selected threshold ($I_{VCC1,peak1,r}$ or $I_{VCC1,peak2,r}$) then the high-power mode regulator will be also activated to support an optimum dynamic load behavior. The current consumption will then increase (approx. 2.8 mA additional quiescent current). The device mode stays unchanged.

If the load current on VCC1 falls below the selected threshold ($I_{VCC1,peak1,f}$ or $I_{VCC1,peak2,f}$), then the low-quiescent current mode is resumed again by disabling the high-power mode regulator.

Both regulators (low-power mode and high-power mode) are active in Normal Mode.

Two different active peak thresholds can be selected via SPI:

- **I_PEAK_TH** = ‘0’ (default): the lower VCC1 active peak threshold 1 is selected with lowest quiescent current consumption in Stop Mode.
- **I_PEAK_TH** = ‘1’: the higher VCC1 active peak threshold 2 is selected with an increased quiescent current consumption in Stop Mode.

Voltage Regulator 1

6.3 Electrical Characteristics

Table 12 Electrical Characteristics

$V_{SINT} = 5.5\text{ V to }28\text{ V}$; $T_j = -40^\circ\text{C to }+150^\circ\text{C}$; all voltages with respect to ground, positive current flowing into pin (unless otherwise specified).

Parameter	Symbol	Values			Unit	Note or Test Condition	Number
		Min.	Typ.	Max.			
Output Voltage including Line and Load Regulation	$V_{CC1,out1}$	4.9	5.0	5.1	V	¹⁾ Normal Mode; $10\ \mu\text{A} < I_{VCC1} < 150\ \text{mA}$;	P_6.3.1
Output Voltage including Line and Load Regulation (Full Load Current Range)	$V_{CC1,out2}$	4.9	5.0	5.1	V	¹⁾ Normal Mode; $6\ \text{V} < V_{SINT} < 28\ \text{V}$; $10\ \mu\text{A} < I_{VCC1} < 250\ \text{mA}$	P_6.3.2
Output Voltage including Line and Load Regulation (Higher Accuracy Range)	$V_{CC1,out3}$	4.95	–	5.05	V	²⁾ Normal Mode; $20\ \text{mA} < I_{VCC1} < 80\ \text{mA}$; $8\ \text{V} < V_{SINT} < 18\ \text{V}$; $25^\circ\text{C} < T_j < 150^\circ\text{C}$	P_6.3.3
Output Voltage including Line and Load Regulation (low-power mode)	$V_{CC1,out4}$	4.9	5.05	5.2	V	Stop Mode; $10\ \mu\text{A} < I_{VCC1} < I_{VCC1,peak}$	P_6.3.4
Output Drop Voltage	$V_{CC1,d1}$	–	200	400	mV	$I_{VCC1} = 50\ \text{mA}$, $V_{SINT} = 5\ \text{V}$	P_6.3.9
Output Drop Voltage	$V_{CC1,d2}$	–	300	500	mV	$I_{VCC1} = 150\ \text{mA}$, $V_{SINT} = 5\ \text{V}$	P_6.3.10
VCC1 Active Peak Threshold 1 (Transition threshold between low-power and high-power mode regulator)	$I_{VCC1,lpeak1,r}$	–	3.25	5.0	mA	²⁾ I_{CC1} rising; $V_{SINT} = 13.5\ \text{V}$; $I_PEAK_TH = '0'$	P_6.3.17
VCC1 Active Peak Threshold 1 (Transition threshold between high-power and low-power mode regulator)	$I_{VCC1,lpeak1,f}$	1.2	1.7	–	mA	²⁾ I_{CC1} falling; $V_{SINT} = 13.5\ \text{V}$; $I_PEAK_TH = '0'$	P_6.3.18
VCC1 Active Peak Threshold 2 (Transition threshold between low-power and high-power mode regulator)	$I_{VCC1,lpeak2,r}$	6	–	20	mA	²⁾ I_{CC1} rising; $V_{SINT} = 13.5\ \text{V}$; $I_PEAK_TH = '1'$	P_6.3.19
VCC1 Active Peak Threshold 2 (Transition threshold between high-power and low-power mode regulator)	$I_{VCC1,lpeak2,f}$	5	–	15	mA	²⁾ I_{CC1} falling; $V_{SINT} = 13.5\ \text{V}$; $I_PEAK_TH = '1'$	P_6.3.20
Overcurrent Limitation	$I_{VCC1,lim}$	260	360	500	mA	current following out of pin, $V_{CC1} = 0\ \text{V}$ ²⁾	P_6.3.21

Voltage Regulator 1

Table 12 Electrical Characteristics (cont'd)

$V_{SINT} = 5.5 \text{ V to } 28 \text{ V}$; $T_j = -40^\circ\text{C to } +150^\circ\text{C}$; all voltages with respect to ground, positive current flowing into pin (unless otherwise specified).

Parameter	Symbol	Values			Unit	Note or Test Condition	Number
		Min.	Typ.	Max.			
Minimum Output Capacitance for stability	$C_{VCC1,min}$	1 ³⁾	–	–	μF	2)	P_6.3.22
Maximum Output Capacitance	$C_{VCC1,max}$	–	–	47	μF	2)	P_6.3.23

- 1) In Stop Mode, the specified output voltage tolerance applies when I_{VCC1} has exceeded the selected active peak threshold ($I_{VCC1,peak1,r}$ or $I_{VCC1,peak2,r}$) but with increased current consumption.
- 2) Not subject to production test, specified by design.
- 3) Value is meant to be an effective value at rated output voltage level.

7 High-Side Switch

7.1 Block Description

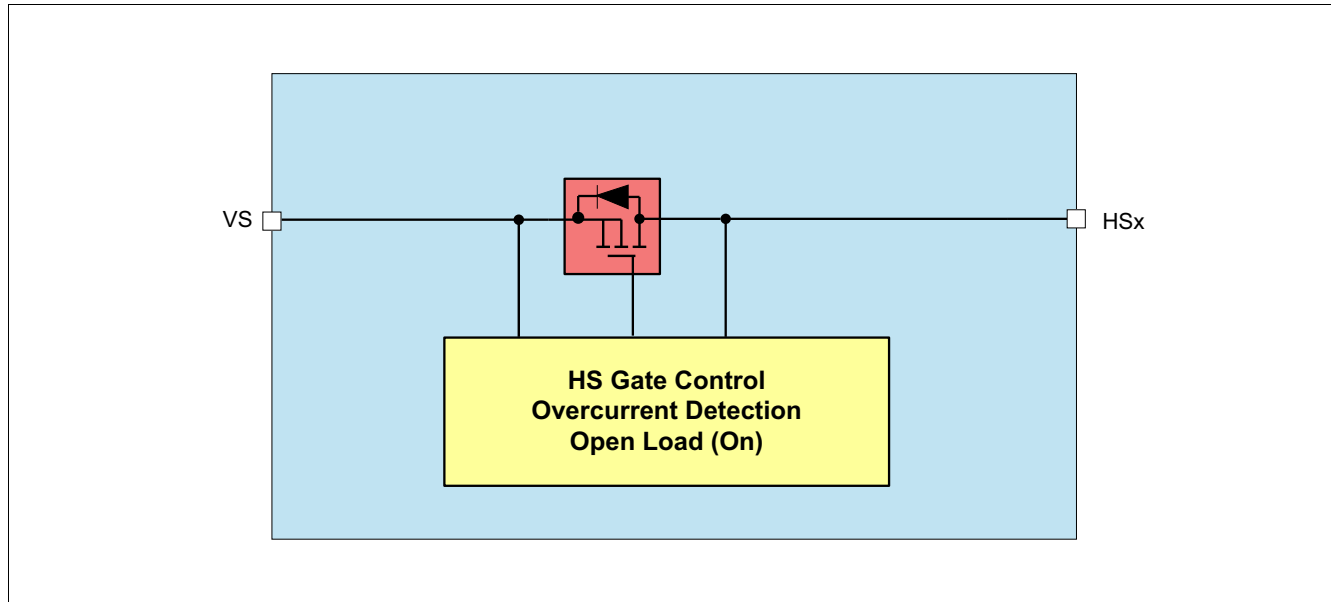

Figure 23 High-Side Module Block Diagram

Features

- All HSx supplied by VS
- Under voltage switch off configurable via SPI.
- Dedicated over voltage switch off per each HSx in Normal Mode- configurable via SPI.
- Overvoltage switch off in Stop Mode and Sleep Mode- configurable via SPI.
- Overcurrent detection and switch off.
- Open load detection in ON-state.
- PWM capability with internal or external timers configurable via SPI.
- Switch recovery after removal of OV or UV condition configurable via SPI.

7.2 Functional Description

The High-Side switches can be used for control of LEDs, as supply for the wake inputs and for other loads (except inductive load). The High-Side outputs can be controlled either directly via SPI by the integrated timers or by the integrated PWM generators or by external sync signal (using WK4/SYNC pin).

The high-side outputs are supplied by VS pin. The topology supports improved cranking condition behavior. The configuration of the High-Sides (Permanent On, PWM, cyclic sense, etc.) drivers must be done in Normal Mode. The configuration is taken over in Stop Mode or Sleep Mode and cannot be modified. When entering Restart Mode or Fail-Safe Mode the HSx outputs are disabled.

7.2.1 Under Voltage Switch Off

All HS drivers in on-state are switched off in case of under voltage on VS. The feature can be disabled by setting the SPI bit [HS_UV_SD_DIS](#).

High-Side Switch

After release of under voltage condition, the HSx switch goes back to programmed state in which it was configured via SPI. This behavior is only valid if the bit **HS_UV_REC** is set. Otherwise the switches will stay off and the respective SPI control bits are cleared.

The under voltage is signaled in the bit **HS_UV**, no other error bits are set.

7.2.2 Over Voltage Switch Off

The HS drivers in on-state are switched off in case of over voltage on VS.. In Normal Mode the HSx can be kept in on-state above the VS overvoltage threshold if the HSx_OV_SDN_DIS bit is set.

In Stop Mode or Sleep Modes all HS drivers can be kept in on-state if **HS_OV_SDS_DIS** bit is set.

When the HSx are configured to switch off in case of over voltage condition, after release of over voltage condition, the HS switch goes back to programmed state in which it was configured via SPI. This behavior is only valid if the respective bit HSx_OV_REC is set. Otherwise the switch will stay off and the respective SPI control bits are cleared. This configuration is available for each HSx.

The over voltage is signaled in the bit **HS_OV**, no other error bits are set.

7.2.3 Over Current Detection and Switch Off

If the load current exceeds the over current shutdown threshold for a time longer then the over current shutdown filter time the output is switched off.

The over current condition and the switch off is signaled with the respective HSx_OC_OT bit in the register **HS_OL_OC_OT_STAT**. The HSx configuration is then reset to 000 by the device. To activate the High-Side again the HSx configuration has to be set to ON (001) or be programmed to a timer function. It is recommended to clear the over current bit before activation the High-Side switch, as the bits are not cleared automatically by the device.

7.2.4 Open Load Detection

Open load detection on the High-Side outputs is done during on state of the output. If the current in the activated output falls below the open load detection current threshold, the open load is detected and signaled via the respective bit HS1_OL, HS2_OL, HS3_OL, or HS4_OL in the register **HS_OL_OC_OT_STAT**. The High-Side output stays activated.. If the open load condition disappears the Open Load bit in the SPI can be cleared. The bits are not cleared automatically by the device.

7.2.5 PWM, Timer and SYNC Function

Each integrated HSx can be configured in different ways, in particular:

- Static OFF
- Static ON
- Timer 1
- Timer 2
- Internal generator PWM1
- Internal generator PWM2
- Internal generator PWM3
- Internal generator PWM4
- SYNC (via WK4)

Note: PWMx mentioned in this chapter refer to the internal PWM generators, which are configured by the registers **HS_CTRL** and **PWM_CTRL**. They can be used to control the internal high-side switches HSx.

High-Side Switch

Note: PWMx mentioned in this chapter **do not refer** to the PWMx pins. The PWMx pins are used for the PWM operation of the bridge drivers, to control the external MOSFETs.

Static configuration (ON/OFF)

This configuration set the HSx permanently ON or OFF. This configuration is available in Normal Mode, Stop Mode and Sleep Mode.

The configuration shall be done via SPI.

Timer configuration (TIMER1 or TIMER2)

Two Timers are dedicated to control the ON phase of dedicated HS outputs.

The Timers are mapped to the dedicated HS outputs. Period and the duty cycle can be independently configured with via SPI.

PWM configuration (PWM1..PWM4)

Several internal PWM generators are dedicated to generate a PWM signal on the HSx output, e.g. for brightness adjustment or compensation of supply voltage fluctuation. The PWM generators are mapped to the dedicated HS outputs, and the duty cycle can be independently configured with a 10-bit resolution via SPI (**PWM_CTRL**). Two different frequencies can be selected independently for every PWM generator in the register **PWM_CTRL**.

In order to assign and configure the PWMx to specific HSX, the follow steps have to be followed:

- Configure duty cycle and frequency for respective PWM generator in **PWM_CTRL**.
- Assign PWM generator to respective HS switch(es) in **HSx_CTRL**.
- The PWM generation will start right after the HSx is assigned to the PWM generator (**HS_CTRL**).

Note: The min. on-time during PWM is limited by the actual on- and off-time of the respective HS switch, e.g. the PWM setting '00 0000 0001' could not be realized.

SYNC configuration (using WK4)

Another possible configuration is to use the WK4 (set as SYNC pin) and mapped to one dedicated HSx output.

The configuration of the WK4/SYNC bit is done using the **WK_EN** bits. If the **WK_EN**=10_B (SYNC selected), all bits in WK4 bank are ignored and wake-up capability on WK4 is not available.

Only after the WK4/SYNC configuration, the HSx can be configured for SYNC usage (HSx = 1000_B).

High-Side Switch

7.3 Electrical Characteristics

Table 13 Electrical Characteristics

$V_{SINT} = 5.5\text{ V to }28\text{ V}$; $T_j = -40^\circ\text{C to }+150^\circ\text{C}$; all voltages with respect to ground, positive current flowing into pin (unless otherwise specified)

Parameter	Symbol	Values			Unit	Note or Test Condition	Number
		Min.	Typ.	Max.			
Output HS1, HS2, HS3, HS4							
Static Drain-Source ON Resistance HSx	$R_{ON,HS25}$	–	7	–	Ω	$I_{ds} = 60\text{ mA}$, $T_j < 25^\circ\text{C}$	P_7.3.1
Static Drain-Source ON Resistance HSx	$R_{ON,HS150}$	–	11.5	16	Ω	$I_{ds} = 60\text{ mA}$, $T_j < 150^\circ\text{C}$	P_7.3.2
Leakage Current HSx / per channel	$I_{leak,HS}$	–	–	2	μA	¹⁾ $0\text{ V} < V_{HSx} < V_{S,HS}$; $T_j < 85^\circ\text{C}$	P_7.3.3
Output Slew Rate (rising)	$SR_{raise,HS}$	0.8	–	2.5	$\text{V}/\mu\text{s}$	¹⁾ 20 to 80% $V_S = 6\text{ to }18\text{ V}$ $R_L = 220\ \Omega$	P_7.3.4
Output Slew Rate (falling)	$SR_{fall,HS}$	-2.5	–	-0.8	$\text{V}/\mu\text{s}$	¹⁾ 80 to 20% $V_S = 6\text{ to }18\text{ V}$ $R_L = 220\ \Omega$	P_7.3.5
Switch-on time HSx	$t_{ON,HS}$	3	–	30	μs	CSN = HIGH to $0.8 \times V_S$; $R_L = 220\ \Omega$; $V_S = 6\text{ to }18\text{ V}$	P_7.3.6
Switch-off time HSx	$t_{OFF,HS}$	3	–	30	μs	CSN = HIGH to $0.2 \times V_S$; $R_L = 220\ \Omega$; $V_S = 6\text{ to }18\text{ V}$	P_7.3.7
Short Circuit Shutdown Current	$I_{SD,HS}$	150	245	300	mA	$V_S = 6\text{ to }20\text{ V}$	P_7.3.8
Short Circuit Shutdown Filter Time	$t_{SD,HS}$	12	16	22	μs	²⁾	P_7.3.9
Open Load Detection Current	$I_{OL,HS}$	0.4	–	2	mA	hysteresis included	P_7.3.10
Open Load Detection hysteresis	$I_{OL,HS,hys}$	–	0.45	–	mA	¹⁾	P_7.3.11
Open Load Detection Filter Time	$t_{OL,HS}$	160	220	270	μs	²⁾	P_7.3.12

1) Not subject to production test, specified by design.

2) Not subject to production test, tolerance defined by internal oscillator tolerance.

8 LIN Transceiver

8.1 Block Description

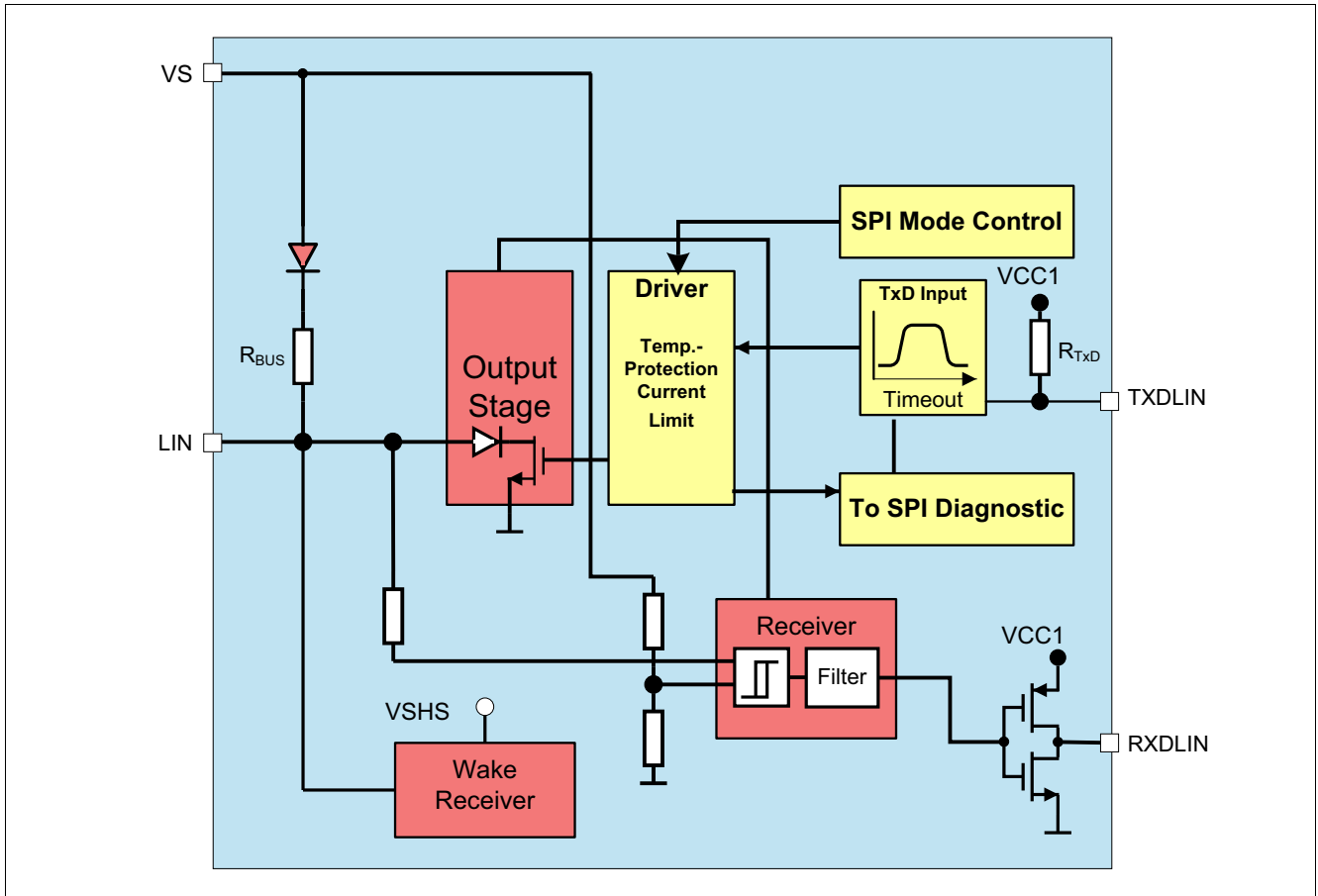

Figure 24 Block Diagram

8.1.1 LIN Specifications

The LIN network is standardized by international regulations.

The device is compliant to:

- ISO17987-4: rev. 2016
- SAE-J2602-2

LIN Transceiver

8.2 Functional Description

The LIN Bus is a single wire, bi-directional bus, used for in-vehicle networks. The LIN transceivers implemented inside the TLE9564QX are the interface between the microcontroller and the physical LIN Bus. The digital output data from the microcontroller are driven to the LIN bus via the TXDLIN pin on the TLE9564QX. The transmit data stream on the TXDLIN is converted to a LIN bus signal with optimized slew rate to minimize the EME level of the LIN network. The RXDLIN sends back the information from the LIN bus to the microcontroller. The receiver has an integrated filter network to suppress noise on the LIN Bus and to increase the EMI (Electro Magnetic Immunity) level of the transceiver.

Two logical states are possible on the LIN Bus according to the LIN specification.

Every LIN network consists of a master node and one or more slave nodes. To configure the TLE9564QX for master node applications, a resistor in the range of 1 kΩ and a reverse diode must be connected between the LIN bus and the power supply VS.

The different transceiver modes can be controlled via the SPI LIN bits.

Figure 25 shows the possible transceiver mode transitions when changing the devicemode.

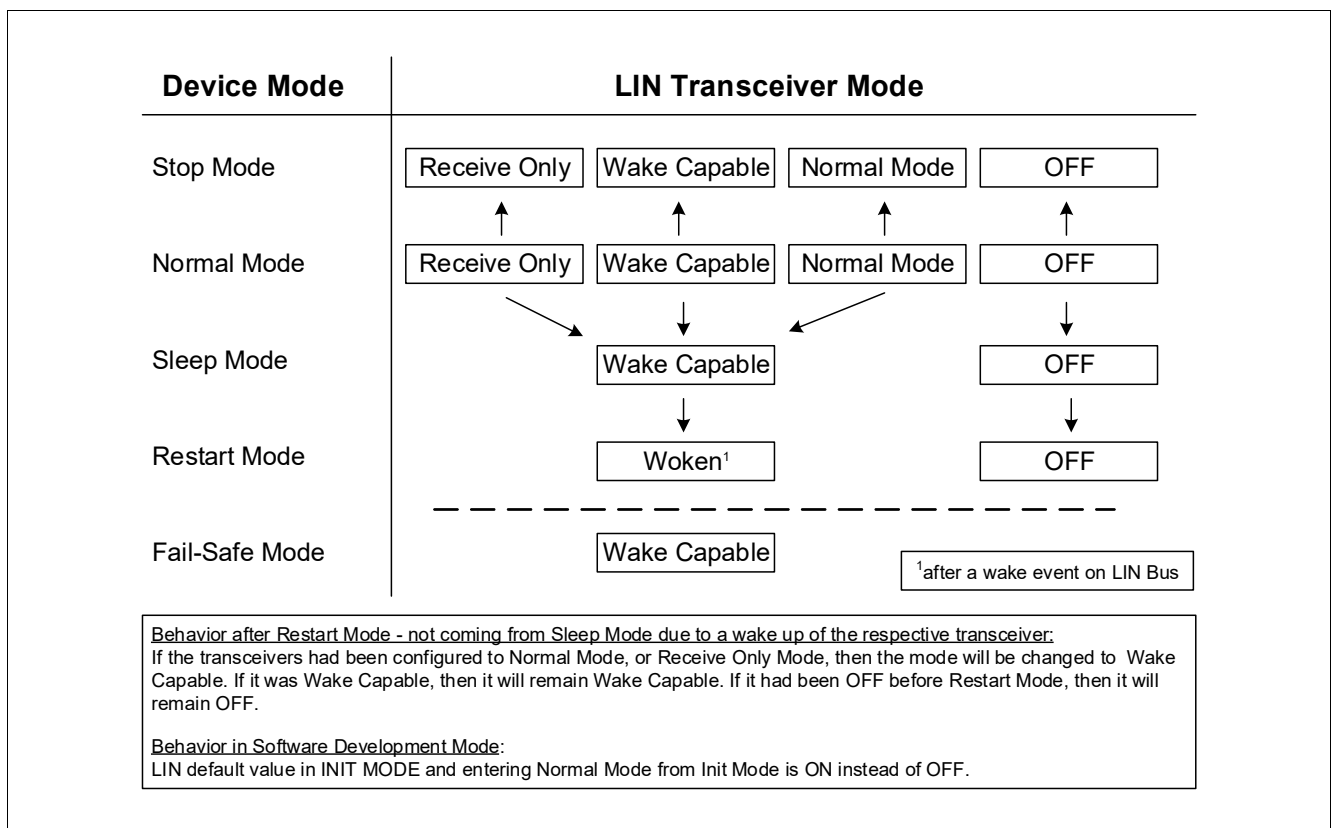

Figure 25 LIN Mode Control Diagram

8.2.1 LIN OFF Mode

The LIN OFF Mode is the default mode after power-up of the device. It is available in all device modes and is intended to completely stop LIN activities or when LIN communication is not needed. In LIN OFF Mode, a wake-up event on the bus will be ignored.

8.2.2 LIN Normal Mode

The LIN Transceiver is enabled via SPI in Normal Mode. LIN Normal Mode is designed for normal data transmission/reception within the LIN network. The mode is available in Normal Mode and in Stop Mode.

LIN Transceiver

Transmission

The signal from the microcontroller is applied to the TXDLIN input of the device. The bus driver switches the LIN output stage to transfer this input signal to the LIN bus line.

Enabling Sequence

The LIN transceiver requires an enabling time $t_{LIN,EN}$ before a message can be sent on the bus. This means that the TXDLIN signal can only be pulled LOW after the enabling time. If this is not ensured, then the TXDLIN needs to be set back to high (=recessive) until the enabling time is completed.

Only the next dominant bit will be transmitted on the bus.

Figure 26 shows different scenarios and explanations for LIN enabling.

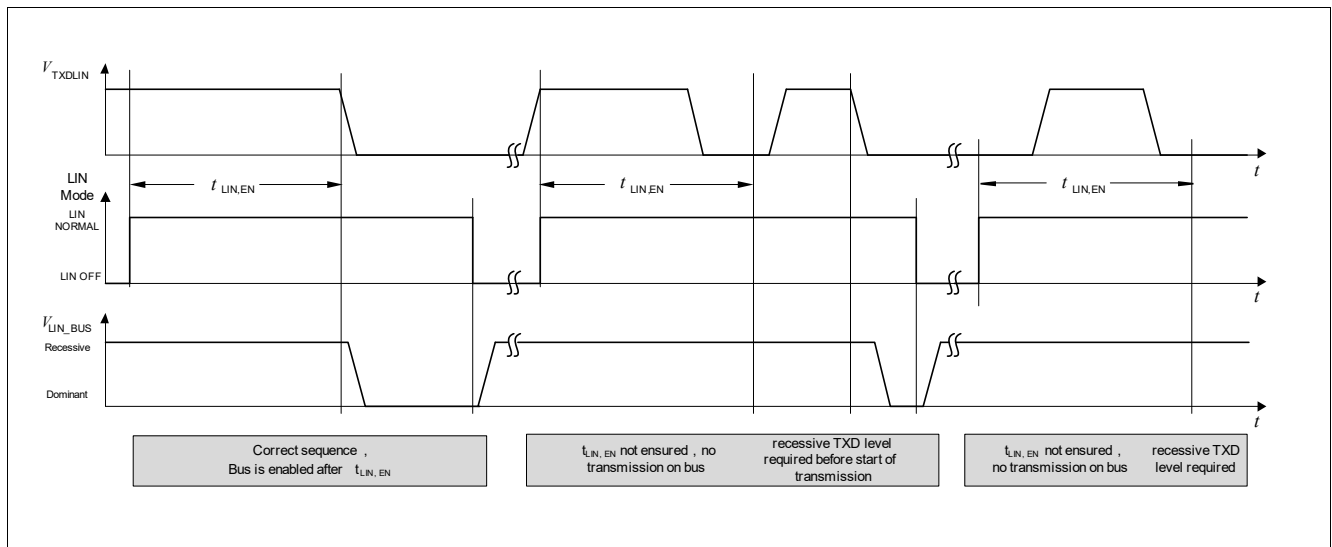

Figure 26 LIN Transceiver Enabling Sequence

Reduced Electromagnetic Emission

To reduce electromagnetic emissions (EME), the bus driver controls LIN slopes symmetrically. The configuration of the different slopes is described in **Chapter 8.2.8**.

Reception

Analog LIN bus signals are converted into digital signals at RXDLIN via the differential input receiver.

8.2.3 LIN Receive Only Mode

In LIN Receive Only Mode (RXD only), the driver stage is de-activated but reception is still possible. This mode is accessible by an SPI command and is available in Normal Mode and Stop Mode.

8.2.4 LIN Wake Capable Mode

This mode can be used in Stop Mode, Sleep Mode, Restart Mode and Normal Mode by programming via SPI and it is used to monitor bus activities. It is automatically accessed in Fail-Safe Mode. A wake up is detected, if a recessive to dominant transition on the LIN bus is followed by a dominant level of longer than $t_{WK,Bus}$ followed by a dominant to recessive transition. The dominant to recessive transition will cause a wake up of the LIN transceiver.

LIN Transceiver

A wake-up results in different behavior of the device, as described in below **Table 14**. As a signalization to the microcontroller, the RXDLIN pin is set LOW and will stay LOW until the LIN transceiver is changed to any other mode. After a wake-up event the transceiver can be switched to LIN Normal Mode for communication.

Table 14 Action due to a LIN BUS Wake-up

Mode	Mode after Wake	VCC1	INTN	RXDLIN
Normal Mode	Normal Mode	ON	LOW	LOW
Stop Mode	Stop Mode	ON	LOW	LOW
Sleep Mode	Restart Mode	Ramping Up	HIGH	LOW
Restart Mode	Restart Mode	ON	HIGH	LOW
Fail-Safe Mode	Restart Mode	Ramping up	HIGH	LOW

Rearming the transceiver for wake capability

After a BUS wake-up event, the transceiver is woken. However, the LIN transceiver mode bits will still show wake capable (=‘01’) so that the RXDLIN signal will be pulled low.

There are two possibilities how the LIN transceiver’s wake capable mode is enabled again after a wake event:

- The LIN transceiver mode must be toggled, i.e. switched to LIN Normal Mode, LIN Receive Only Mode or LIN OFF Mode, before switching to LIN Wake Capable Mode again.
- Rearming is done automatically when the device is changed to Stop Mode, Sleep Mode or Fail-Safe Mode to ensure wake-up capability.

Wake-Up in Stop Mode and Normal Mode

In Stop Mode, if a wake-up is detected, it is signaled by the INTN output and in the **WK_STAT** SPI register. It is also signaled by RXDLIN put to LOW. The same applies for the Normal Mode. The microcontroller should set the device to Normal Mode, there is no automatic transition to Normal Mode.

For functional safety reasons, the watchdog will be automatically enabled in Stop Mode after a Bus wake event in case it was disabled before (if bit **WD_EN_WK_BUS** was configured to HIGH before).

Wake-Up in Sleep Mode

One wake-up event on the LIN Bus from Sleep or Fail-Safe Mode automatically transfers the device into the Restart Mode and from there to Normal Mode. The corresponding RXD pin in set to LOW. The microcontroller is able to detect the low signal on RXD and to read the wake source out of the **WK_STAT** register via SPI. No interrupt is generated when coming out of Sleep or Fail-Safe Mode. The microcontroller can now switch the LIN transceiver into LIN Normal Mode via SPI to start communication.

8.2.5 TXD Time-out Feature

If the TXDLIN signal is dominant for the time $t > t_{TXD_LIN_TO}$, the TXD time-out function deactivates the LIN transmitter output stage temporarily. The transceiver remains in recessive state. The TXD time-out function prevents the LIN bus from being blocked by a permanent LOW signal on the TXDLIN pin, caused by a failure. The failure is stored in the SPI flag **LIN_FAIL**. The LIN transmitter stage is activated again after the dominant time-out condition is removed. The transceiver configuration stays unchanged.

LIN Transceiver

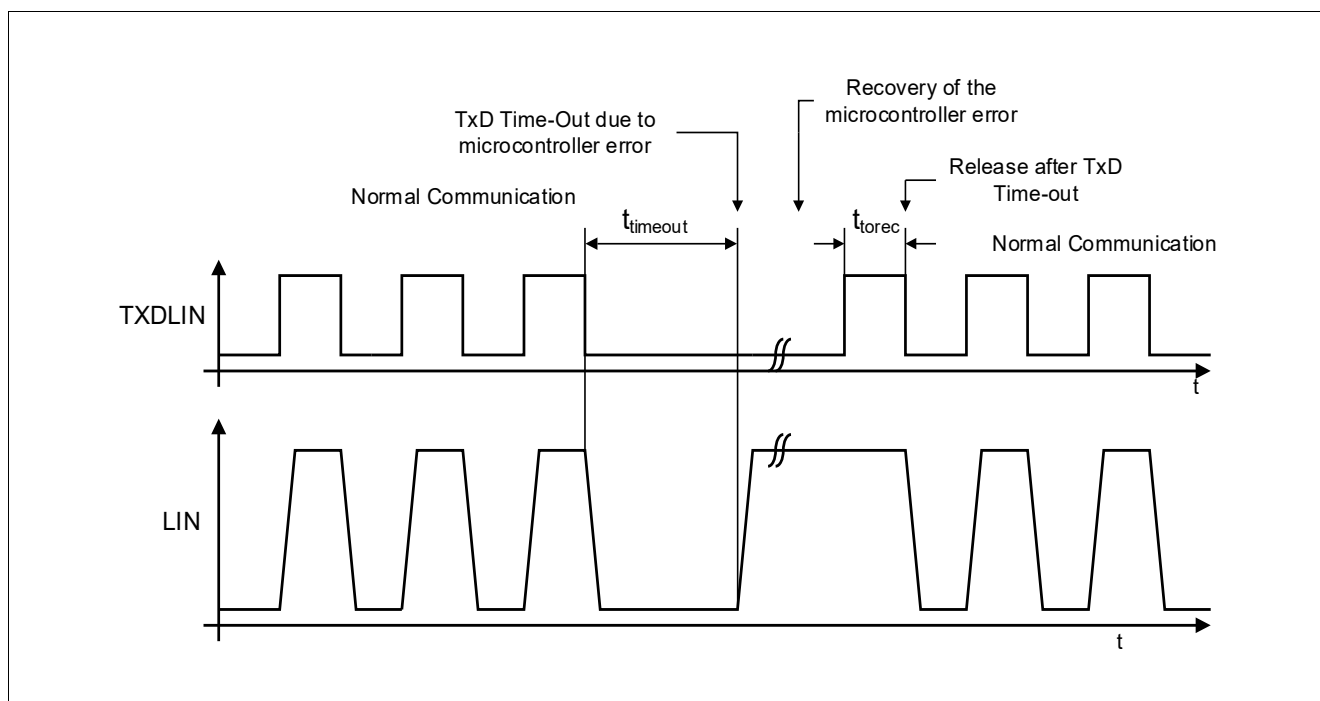

Figure 27 TXD Time-Out Function

8.2.6 Bus Dominant Clamping

If the LIN bus signal is dominant for a time $t > t_{BUS_LIN_TO}$ in LIN Normal Mode and LIN Receive Only Mode, then a bus dominant clamping is detected and the SPI bit **LIN_FAIL** is set. The transceiver configuration stays unchanged.

8.2.7 Under-Voltage Detection

In case the supply voltage is dropping below the VS undervoltage detection threshold ($V_S < V_{s,uv}$), the TLE9564QX disables the output and receiver stages. If the power supply reaches a higher level than the undervoltage detection threshold ($V_S > V_{s,uv}$), the TLE9564QX continues with normal operation. The transceiver configuration stays unchanged.

8.2.8 Slope Selection

The LIN transceiver offers a LIN Low-Slope Mode for 10.4 kBaud communication and a LIN Normal-Slope Mode for 20 kBaud communication. The only difference is the behavior of the transmitter. In LIN Low-Slope Mode, the transmitter uses a lower slew rate to further reduce the EME compared to Normal-Slope Mode. This complies with SAE J2602 requirements. By default, the device works in LIN Normal-Slope Mode. The selection of LIN Low-Slope Mode is done by an SPI bit **LIN_LSM** and will become effective as soon as CSN goes 'HIGH'. Only the LIN Slope is changed. The selection is accessible in Normal Mode only.

8.2.9 Flash Programming via LIN

The device allows LIN flash programming, e.g. of another LIN Slave with a communication of up to 115 kBaud. This feature is enabled by de-activating the slope control mechanism via a SPI command (bit **LIN_FLASH**) and will become effective as soon as CSN goes 'HIGH'. The SPI bit can be set in Normal Mode.

Note: It is recommended to perform flash programming only at nominal supply voltage $V_S = 13.5 V$ to ensure stable data communication.

LIN Transceiver

8.3 Electrical Characteristics

Table 15 Electrical Characteristics

$V_{SHS} = 5.5\text{ V to }18\text{ V}$, $T_j = -40^\circ\text{C to }+150^\circ\text{C}$, $R_L = 500\ \Omega$, all voltages with respect to ground, positive current flowing into pin (unless otherwise specified)

Parameter	Symbol	Values			Unit	Note or Test Condition	Number
		Min.	Typ.	Max.			
Receiver Output (RXD pin)							
HIGH Level Output Voltage	$V_{RXD,H}$	$0.8 \times V_{CC1}$	–	–	V	$I_{RXD} = -2\text{ mA}$; $V_{Bus} = V_S$	P_9.3.1
LOW Level Output Voltage	$V_{RXD,L}$	–	–	$0.2 \times V_{CC1}$	V	$I_{RXD} = 2\text{ mA}$; $V_{Bus} = 0\text{ V}$	P_9.3.2
Transmission Input (TXD pin)							
HIGH Level Input Voltage	$V_{TXD,H}$	–	–	$0.7 \times V_{CC1}$	V	Recessive State	P_9.3.3
TXD Input Hysteresis	$V_{TXD,hys}$	–	$0.12 \times V_{CC1}$	–	V	¹⁾	P_9.3.4
LOW Level Input Voltage	$V_{TXD,L}$	$0.3 \times V_{CC1}$	–	–	V	Dominant State	P_9.3.5
TXD Pull-up Resistance	R_{TXD}	20	40	80	k Ω	$V_{TXD} = 0\text{ V}$	P_9.3.6
LIN Bus Receiver (LIN Pin)							
Receiver Threshold Voltage, Recessive to Dominant Edge	$V_{Bus,rd}$	$0.4 \times V_S$	$0.45 \times V_S$	–	V		P_9.3.7
Receiver Dominant State	$V_{Bus,dom}$	–	–	$0.4 \times V_S$	V	LIN 2.2 Param. 17	P_9.3.8
Receiver Threshold Voltage, Dominant to Recessive Edge	$V_{Bus,dr}$	–	$0.55 \times V_S$	$0.60 \times V_S$	V		P_9.3.9
Receiver Recessive State	$V_{Bus,rec}$	$0.6 \times V_S$	–	–	V	LIN 2.2 Param 18	P_9.3.10
Receiver Center Voltage	$V_{Bus,c}$	$0.475 \times V_S$	$0.5 \times V_S$	$0.525 \times V_S$	V	LIN 2.2 Param 19 $6\text{ V} < V_S < 18\text{ V}$	P_9.3.11
Receiver Hysteresis	$V_{Bus,hys}$	$0.07 \times V_S$	$0.1 \times V_S$	$0.175 \times V_S$	V	$V_{bus,hys} = V_{bus,dr} - V_{bus,rd}$ LIN 2.2 Param 20	P_9.3.12
Wake-up Threshold Voltage	$V_{Bus,wk}$	$0.40 \times V_S$	$0.5 \times V_S$	$0.6 \times V_S$	V	–	P_9.3.13
Dominant Time for Bus Wake-up	$t_{WK,Bus}$	30	–	150	μs	²⁾	P_9.3.14

LIN Transceiver

Table 15 Electrical Characteristics (cont'd)

$V_{SHS} = 5.5\text{ V to }18\text{ V}$, $T_j = -40^\circ\text{C to }+150^\circ\text{C}$, $R_L = 500\ \Omega$, all voltages with respect to ground, positive current flowing into pin (unless otherwise specified)

Parameter	Symbol	Values			Unit	Note or Test Condition	Number
		Min.	Typ.	Max.			
LIN Bus Transmitter (LIN Pin)							
Bus Serial Diode Voltage Drop	V_{serdiode}	0.4	0.7	1.0	V	¹⁾ $V_{\text{TXD}} = \text{VCC1}$; LIN 2.2 Param 21	P_9.3.15
Bus Recessive Output Voltage	$V_{\text{BUS,ro}}$	$0.8 \times V_S$	–	V_S	V	$V_{\text{TXD}} = \text{HIGH Level}$	P_9.3.16
Bus Short Circuit Current	$I_{\text{BUS,sc}}$	40	100	150	mA	$V_{\text{BUS}} = 18\text{ V}$; LIN 2.2 Param 12	P_9.3.20
Leakage Current Loss of Ground	$I_{\text{BUS,lk1}}$	-1000	-450	20	μA	$V_S = 12\text{ V} = \text{GND}$; $0\text{ V} < V_{\text{BUS}} < 18\text{ V}$; LIN 2.2 Param 15	P_9.3.21
Leakage Current Loss of Battery	$I_{\text{BUS,lk2}}$	–	–	20	μA	$V_S = 0\text{ V}$; $V_{\text{BUS}} = 18\text{ V}$; LIN 2.2 Param 16	P_9.3.22
Leakage Current Driver Off	$I_{\text{BUS,lk3}}$	-1	–	–	mA	$V_S = 18\text{ V}$; $V_{\text{BUS}} = 0\text{ V}$; LIN 2.2 Param 13	P_9.3.23
Leakage Current Driver Off	$I_{\text{BUS,lk4}}$	–	–	20	μA	$V_S = 8\text{ V}$; $V_{\text{BUS}} = 18\text{ V}$; LIN 2.2 Param 14	P_9.3.24
Bus Pull-up Resistance	R_{BUS}	20	30	47	k Ω	Normal Mode LIN 2.2 Param 26	P_9.3.25
LIN Input Capacitance	C_{BUS}		20	25	pF	¹⁾	P_9.3.26
Receiver propagation delay bus dominant to RXD LOW	$t_{\text{d(L),R}}$	–	1	6	μs	$V_{\text{CC}} = 5\text{ V}$; $C_{\text{RXD}} = 20\text{ pF}$; LIN 2.2 Param 31	P_9.3.27
Receiver propagation delay bus recessive to RXD HIGH	$t_{\text{d(H),R}}$	–	1	6	μs	$V_{\text{CC}} = 5\text{ V}$; $C_{\text{RXD}} = 20\text{ pF}$; LIN 2.2 Param 31	P_9.3.28
Receiver delay symmetry	$t_{\text{sym,R}}$	-2	–	2	μs	$t_{\text{sym,R}} = t_{\text{d(L),R}} - t_{\text{d(H),R}}$; LIN 2.2 Param 32	P_9.3.29
LIN Transceiver Enabling Time	$t_{\text{LIN,EN}}$	8	13	18	μs	²⁾ CSN = HIGH to first valid transmitted TXD dominant	P_9.3.30
Bus Dominant Time Out	$t_{\text{BUS_LIN_TO}}$	–	20	–	ms	¹⁾²⁾	P_9.3.31
TXD Dominant Time Out	$t_{\text{TXD_LIN_TO}}$	–	20	–	ms	¹⁾²⁾ $V_{\text{TXD}} = 0\text{ V}$	P_9.3.32
TXD Dominant Time Out Recovery Time	t_{torec}	–	10	–	μs	¹⁾²⁾	P_9.3.33

LIN Transceiver

Table 15 Electrical Characteristics (cont'd)

$V_{SHS} = 5.5\text{ V to }18\text{ V}$, $T_j = -40^\circ\text{C to }+150^\circ\text{C}$, $R_L = 500\ \Omega$, all voltages with respect to ground, positive current flowing into pin (unless otherwise specified)

Parameter	Symbol	Values			Unit	Note or Test Condition	Number
		Min.	Typ.	Max.			
Duty Cycle D1 (For worst case at 20 kbit/s) LIN 2.2 Normal Slope	D1	0.396	–	–		³⁾ $TH_{Rec}(max) = 0.744 \times V_S$; $TH_{Dom}(max) = 0.581 \times V_S$; $V_S = 7.0 \dots 18\text{ V}$; $t_{bit} = 50\ \mu\text{s}$; $D1 = t_{bus_rec(min)}/2 t_{bit}$; LIN 2.2 Param 27	P_9.3.34
Duty Cycle D2 (for worst case at 20 kbit/s) LIN 2.2 Normal Slope	D2	–	–	0.581		³⁾ $TH_{Rec}(min.) = 0.422 \times V_S$; $TH_{Dom}(min.) = 0.284 \times V_S$; $V_S = 7.6 \dots 18\text{ V}$; $t_{bit} = 50\ \mu\text{s}$; $D2 = t_{bus_rec(max)}/2 t_{bit}$; LIN 2.2 Param 28	P_9.3.35
Duty Cycle D3 (for worst case at 10.4 kbit/s) SAE J2602 Low Slope	D3	0.417	–	–		³⁾ $TH_{Rec}(max) = 0.778 \times V_S$; $TH_{Dom}(max) = 0.616 \times V_S$; $V_S = 7.0 \dots 18\text{ V}$; $t_{bit} = 96\ \mu\text{s}$; $D3 = t_{bus_rec(min)}/2 t_{bit}$; LIN 2.2 Param 29	P_9.3.36
Duty Cycle D4 (for worst case at 10.4 kbit/s) SAE J2602 Low Slope	D4	–	–	0.590		³⁾ $TH_{Rec}(min.) = 0.389 \times V_S$; $TH_{Dom}(min.) = 0.251 \times V_S$; $V_S = 7.6 \dots 18\text{ V}$; $t_{bit} = 96\ \mu\text{s}$; $D4 = t_{bus_rec(max)}/2 t_{bit}$; LIN 2.2 Param 30	P_9.3.37

- 1) Not subject to production test, specified by design.
- 2) Not subject to production test, tolerance defined by internal oscillator tolerance.
- 3) Bus load conditions concerning LIN Specification 2.2 C_{LIN} , $R_{LIN} = 1\text{ nF}$, $1\text{ k}\Omega$ / 6.8 nF , $660\ \Omega$ / 10 nF , $500\ \Omega$.

LIN Transceiver

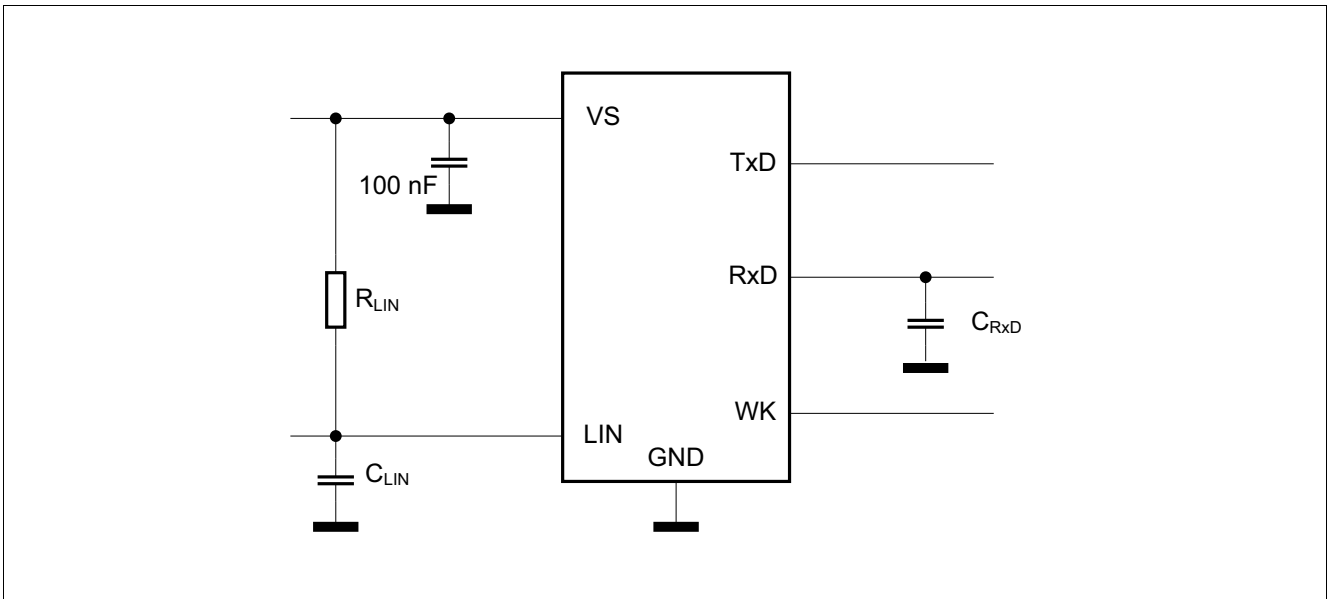

Figure 28 Simplified Test Circuit for Dynamic Characteristics

LIN Transceiver

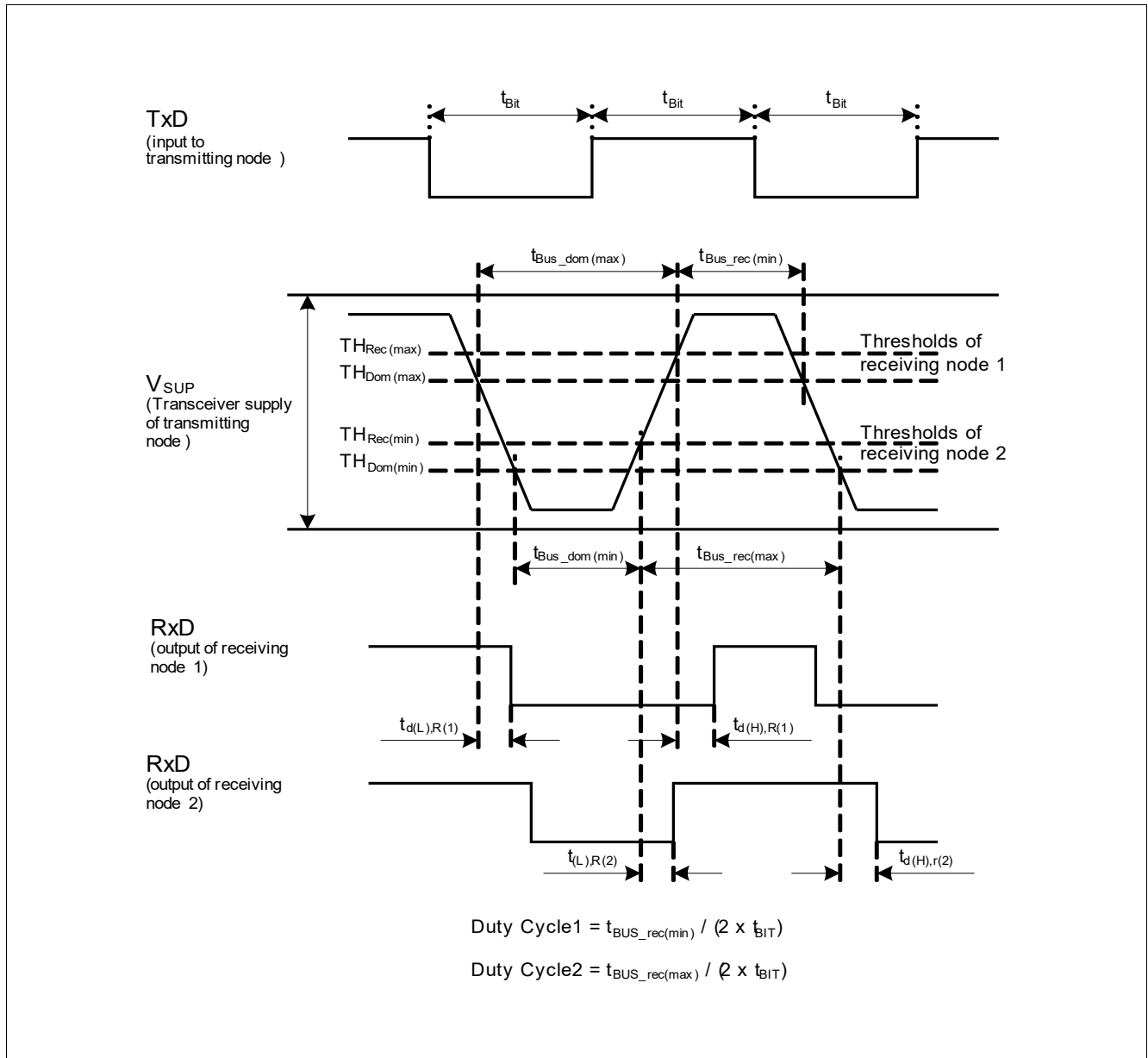

Figure 29 Timing Diagram for Dynamic Characteristics

9 High-Voltage Wake Input

9.1 Block Description

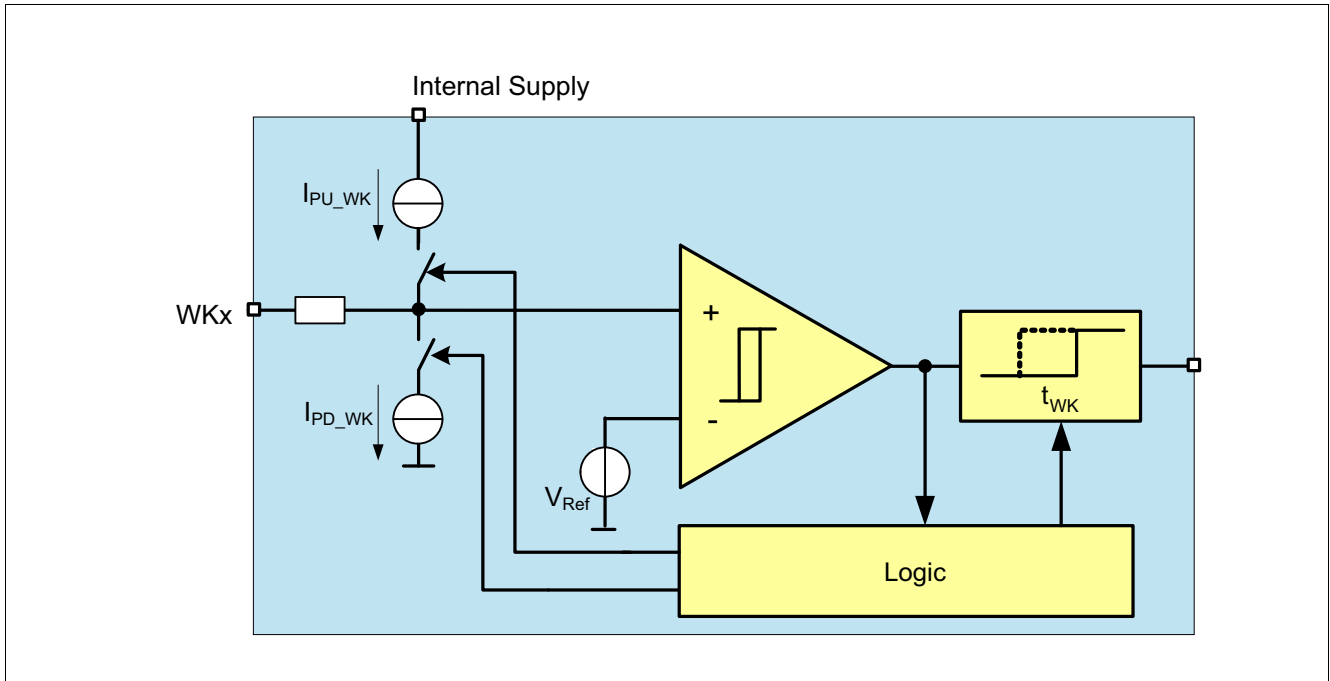

Figure 30 Wake Input Block Diagram

Features

- High-Voltage inputs with a 3 V (typ.) threshold voltage.
- Wake-up capability for power saving modes.
- Edge sensitive wake feature low to high and high to low.
- Pull-up and Pull-down current sources, configurable via SPI.
- Selectable configuration for static sense or cyclic sense.
- In Normal Mode and Stop Mode the level of the WKx pin can be read via SPI unless WK4 is configured as SYNC.
- Synchronization with HSx via WK4 (for cyclic sense).

9.2 High-Voltage Wake Function

9.2.1 Functional Description

The wake inputs pin are edge-sensitive inputs with a switching threshold of typically 3 V. Both transitions, high to low and low to high, result in a signalization by the device. The signalization occurs either in triggering the interrupt in Normal Mode and Stop Mode or by a wake up of the device in Sleep Mode and Fail-Safe Mode.

Two different wake detection modes can be selected via SPI:

- Static sense: WK inputs are always active.
- Cyclic sense: WK inputs are only active for a certain time period (see [Chapter 5.7.1](#)).

A filter time t_{FWKx} is implemented to avoid an unintentional wake-up due to transients or EMC disturbances in static sense configuration.

The filter time (t_{FWKx}) is triggered by a level change crossing the switching threshold and a wake signal is recognized if the input level will not cross again the threshold during the selected filter time.

[Figure 31](#) shows a typical wake-up timing and filtering of transient pulses.

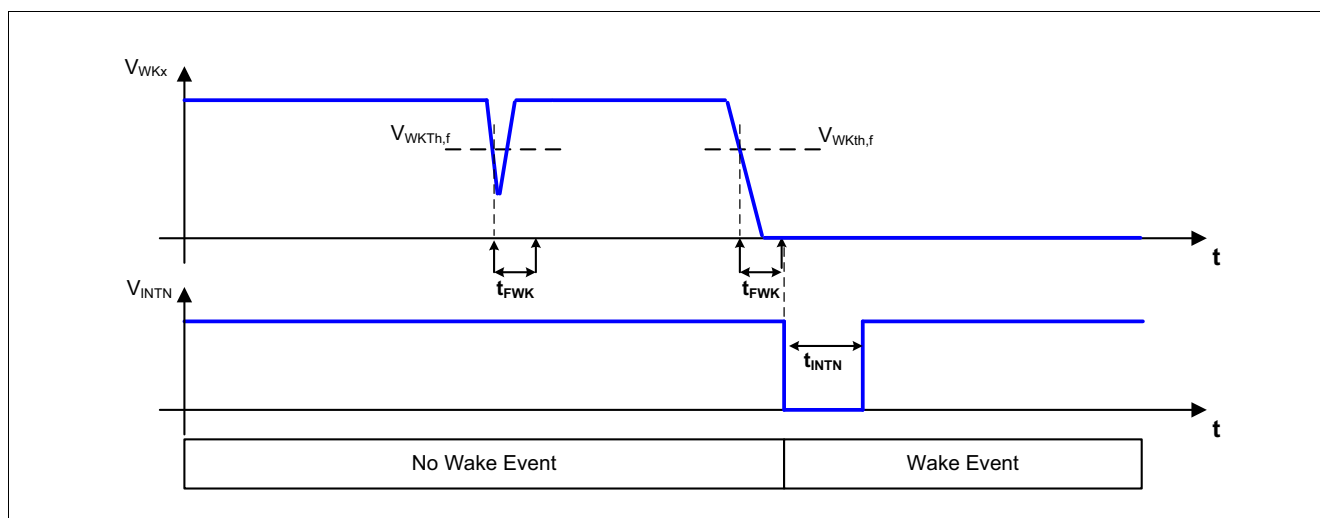

Figure 31 Wake-up Filter Timing for Static Sense

The wake-up capability for the WKx pin can be enabled or disabled via SPI command.

A wake event via the WKx pin can always be read in the register [WK_STAT](#).

The actual voltage level of the WKx pin (low or high) can always be read in Normal Mode, Stop Mode and Init Mode in the register [WK_LVL_STAT](#). During Cyclic Sense, the register shows the sampled levels of the respective WKx pin.

9.2.2 Wake Input Configuration

To ensure a defined and stable voltage levels at the internal comparator input it is possible to configure integrated current sources via the SPI register [WK_CTRL](#).

High-Voltage Wake Input

Table 16 Pull-Up / Pull-Down Resistor

WKx_PUPD_ 1	WKx_PUPD_ 0	Current Sources	Note
0	0	no current source	WK input is floating if left open (default setting)
0	1	pull-down	WK input internally pulled to GND
1	0	pull-up	WK input internally pulled to internal 5V supply
1	1	Automatic switching	If a high level is detected at the WK input the pull-up source is activated, if low level is detected the pull down is activated.

Note: If a WK input is not used, the respective WK input must be tied to GND on board to avoid unintended floating state of the pin.

One additional configuration is related the filter time of each Wake-up module. The bits **WK_FILT** permit to set the filter time in static sensing or in cyclic sensing.

Note: When the device mode is changed to normal (from INIT), in case of static sense, if the WK pin is set, the WK_STAT register is set in this time (also the interrupt pin).

9.2.3 Wake configuration for Cyclic Sense

The wake-up inputs can also be used for cyclical sensing signals during low-power modes. For this function the WKx input performs a cyclic sensing of the voltage level during the on-time of specific HSx. A transition of the voltage level will trigger a wake-up event. See also **Chapter 5.7.1** for more details.

9.2.4 Wake configuration for Synchronization

The WK4 pin can be configured as SYNC input for driving the HSx.

Prerequisite to configure the WK4 as SYNC input is that the WK4 has to be OFF.

The configuration of the WK4/SYNC bit is done using the **WK_EN** bits. if the **WK_EN=10_B** (SYNC selected), all bits in WK4 bank are ignored and wake-up capability on WK4 is not available.

Note: If WKx is the only wake source available and is configured with cyclic sense with SYNC (WKx_FILT = 100), trying to go to Sleep Mode is not possible (restart mode is entered) - because SYNC is driven by the microcontroller which is not supplied in Sleep Mode.

High-Voltage Wake Input

9.3 Electrical Characteristics

Table 17 Electrical Characteristics

$V_{SINT} = 5.5\text{ V to }28\text{ V}$; $T_j = -40^\circ\text{C to }+150^\circ\text{C}$; all voltages with respect to ground, positive current flowing into pin (unless otherwise specified)

Parameter	Symbol	Values			Unit	Note or Test Condition	Number
		Min.	Typ.	Max.			
WK4 Input Pin Characteristics							
Wake-up/monitoring threshold voltage falling	$V_{WKx_th,f}$	2.5	3	3.5	V	without external serial resistor R_S	P_10.3.1
Wake-up/monitoring threshold voltage rising	$V_{WKx_th,r}$	3	3.5	4	V	without external serial resistor R_S	P_10.3.2
Threshold hysteresis	$V_{WKx_th,hys}$	0.4	0.6	0.85	V	without external serial resistor R_S	P_10.3.3
WK pin Pull-up Current	I_{PU_WKx}	-20	-10	-3	μA	$V_{WKx} = 4\text{ V}$	P_10.3.4
WK pin Pull-down Current	I_{PD_WKx}	3	10	20	μA	$V_{WKx} = 2.5\text{ V}$	P_10.3.5
Input leakage current	$I_{LK,lx}$	-2		2	μA	$0\text{ V} < V_{WKx} < 40\text{ V}$; Pull-up / Pull-down disabled	P_10.3.6

WK4 as SYNC input pin

LOW input voltage threshold	$WK4_{SYNC_th,L}$	$0.3 \times V_{CC1}$	-	-	V		P_10.3.11
HIGH input voltage threshold	$WK4_{SYNC_th,H}$	-	-	$0.7 \times V_{CC1}$	V		P_10.3.12
Pull-down resistance on WK/SYNC	R_{SYNC}	20	40	80	k Ω	$V_{SYNC} = 1\text{ V}$	P_10.3.13

Timing

Wake-up filter time 1	t_{FWK1}	12	16	22	μs	1)	P_10.3.16
Wake-up filter time 2	t_{FWK2}	50	64	80	μs	1)	P_10.3.17

1) Not subject to production test, tolerance defined by internal oscillator tolerance.

Interrupt Function

10 Interrupt Function

10.1 Block and Functional Description

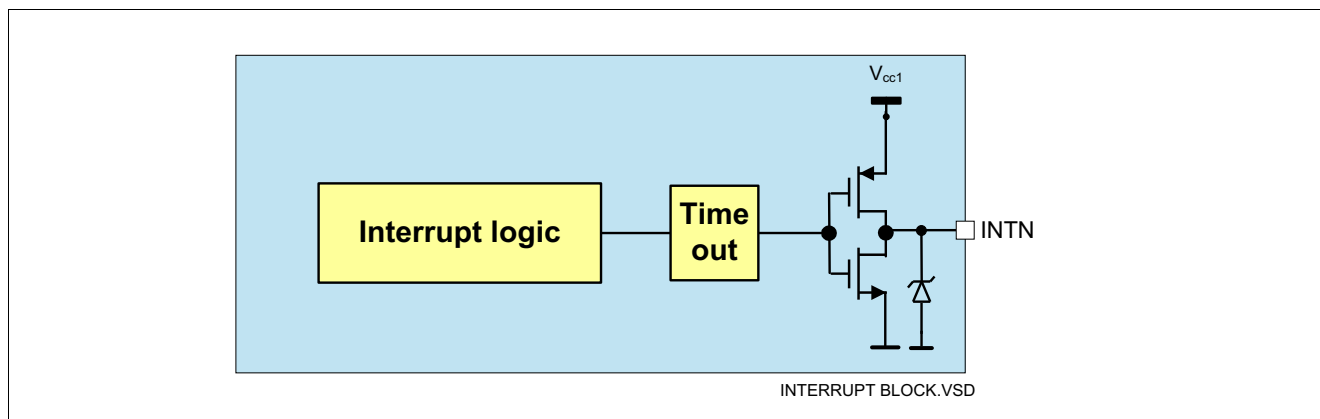

Figure 32 Interrupt Block Diagram

The interrupt is used to signalize special events in real time to the microcontroller. The interrupt block is designed as a push/pull output stage as shown in [Figure 32](#). An interrupt is triggered and the INTN pin is pulled low (active low) for t_{INTN} in Normal Mode and Stop Mode and it is released again once t_{INTN} is expired. The minimum high-time of INTN between two consecutive interrupts is t_{INTND} . An interrupt does not cause a device mode change.

Two different interrupt generation methods are implemented:

- Interrupt Mask: One dedicated register (INT_MASK) is intended to enable or disable set of interrupt sources. The interrupt sources follow the SPI Status Information Field.
In details:
 - SUPPLY_STAT: “OR” of all bits on SUP_STAT register except POR, VCC1_UV, VCC1_SC, VCC1_OV
 - TEMP_STAT: “OR” of all bits on THERM_STAT register except TSD2
 - BUS_STAT: “OR” of all bits on BUS_STAT register
 - HS_STAT: “OR” of all bits on HS_OL_OC_OT_STAT register
 - BD_STAT: “OR” of all bits on DSOV register
 - SPI_CRC_FAIL: or between SPI_FAIL and CRC_FAIL bits on DEV_STAT register.
- Wake-up events: all wake-up events stored in the wake status SPI register WK_STAT only in case the corresponding input was configured as wake-up source.
The wake-up sources are:
 - via LIN
 - via WK pin
 - via TIMERx (cyclic wake)
 - via LSx_DSOV_BRK if any of the brake-feature is enabled

The methods are both available at the same time.

Note: The errors which will cause Restart or Fail-Safe Mode (VCC1_UV, VCC1_SC, VCC1_OV, TSD2) are the exceptions of an INTN generation. Also the bit POR will not generate interrupts. If the above mentioned bits are not cleared after the device is back in Normal Mode or Stop Mode, the INTN is periodically generated (Register based cyclic interrupt generation).

Interrupt Function

Note: Periodical interrupts are only generated by CRC fail and SPI fail from DEV_STAT register.

Note: During Restart Mode the SPI is blocked and the microcontroller is in reset. Therefore the INTN will not be in Restart Mode, which is the same behavior in Fail-Safe Mode or Sleep Mode.

In addition to this behavior, INTN will be triggered when Stop Mode is entered and not all wake source bits were cleared in the WK_STAT register and also the LSx_DSOV_BRK bits in the DSOV register..

The SPI status registers are updated at every falling edge of the INTN pulse. All interrupt events are stored in the respective register until the register is cleared via SPI command. A second SPI read after reading out the respective status register is optional but recommended to verify that the interrupt event is not present anymore. The interrupt behavior is shown in **Figure 33**.

The INTN pin is also used during Init Mode to select the Software Development Mode entry. See **Chapter 5.2** for further information.

In case of pending INTN event (SPI Status registers are not cleared after INTN event), additional periodical INTN events are generated as shown in **Figure 34**.

The periodical INTN events generation can be disabled via SPI command using **INTN_CYC_EN** bit.

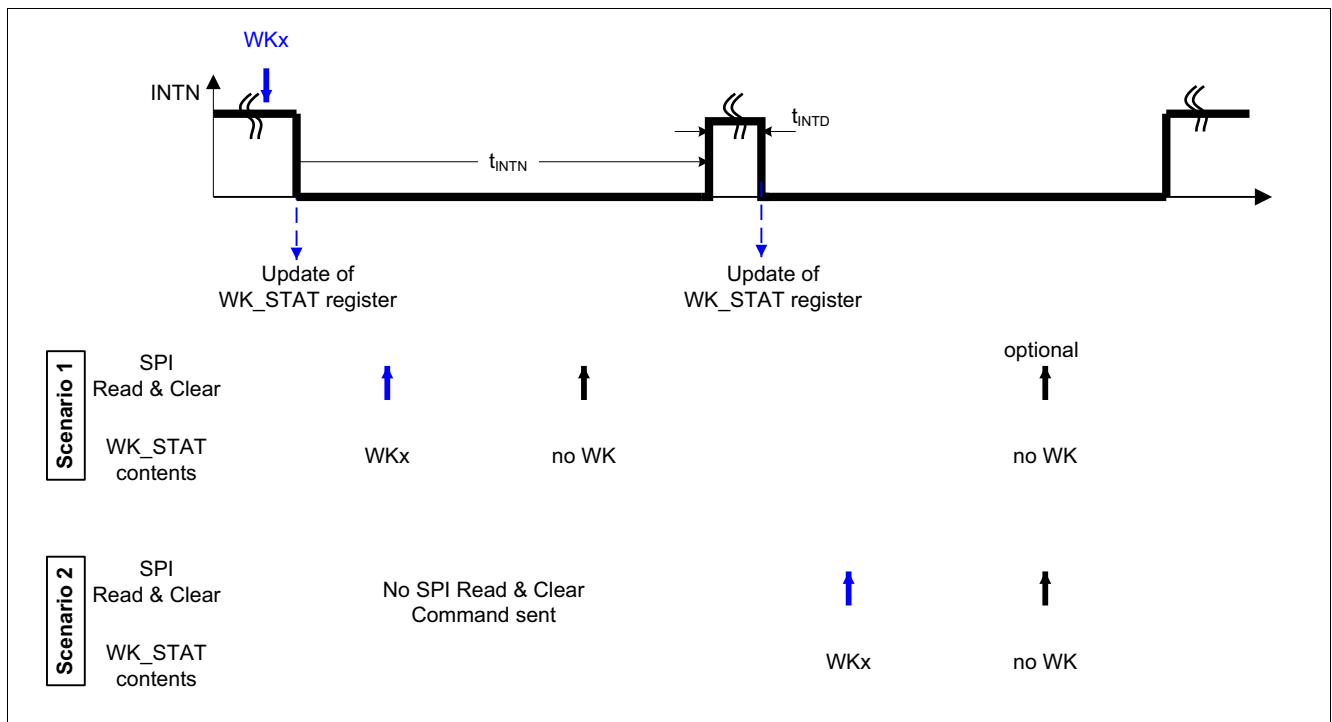

Figure 33 Interrupt Signalization Behavior

Note: For two or more interrupt events at the same time, when INTN pin is low the same time, it will not start multiple toggling.

Interrupt Function

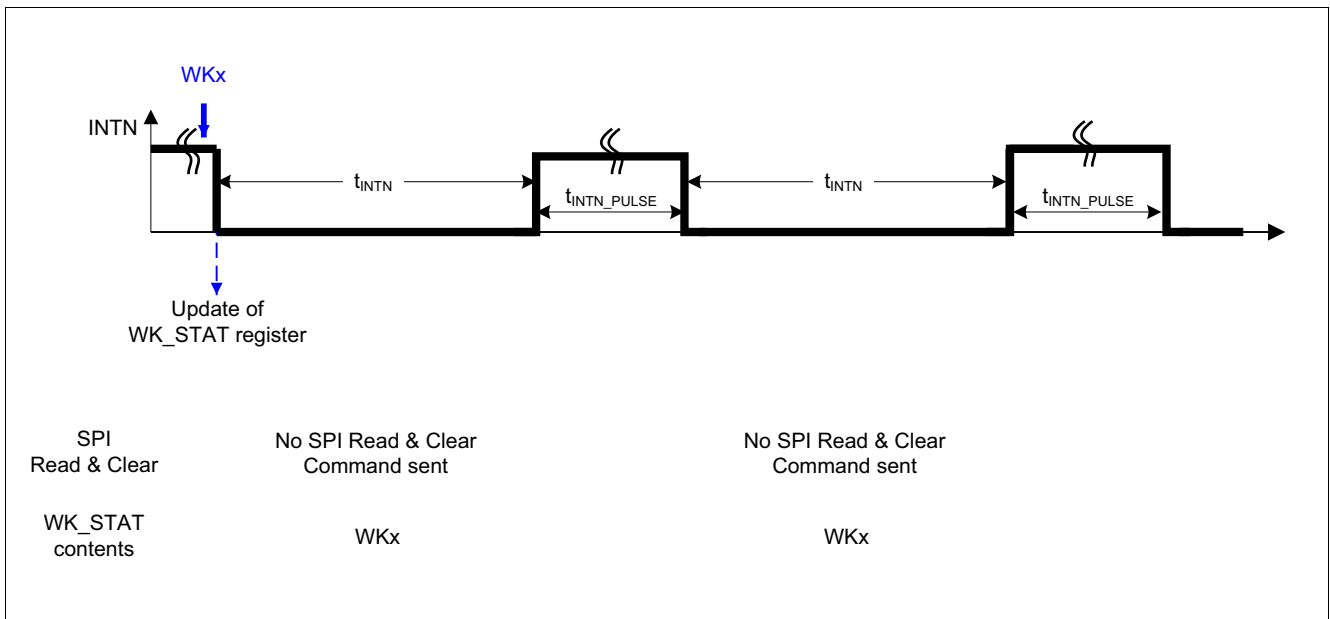

Figure 34 Interrupt Signalization Behavior in case of pending INTN events

Interrupt Function

10.2 Electrical Characteristics

Table 18 Electrical Characteristics

$V_{SINT} = 5.5\text{ V to }28\text{ V}$; $T_j = -40^\circ\text{C to }+150^\circ\text{C}$; Normal Mode; all voltages with respect to ground; positive current defined flowing into pin; unless otherwise specified.

Parameter	Symbol	Values			Unit	Note or Test Condition	Number
		Min.	Typ.	Max.			
Interrupt Output; Pin INTN							
INTN High Output Voltage	$V_{INTN,H}$	$0.8 \times V_{CC1}$	–	–	V	¹⁾ $I_{INTN} = -2\text{ mA}$; INTN = off	P_11.2.1
INTN Low Output Voltage	$V_{INTN,L}$	–	–	$0.2 \times V_{CC1}$	V	¹⁾ $I_{INTN} = 2\text{ mA}$; INTN = on	P_11.2.2
INTN Pulse Width	t_{INTN}	80	100	120	μs	²⁾	P_11.2.3
INTN Pulse Minimum Delay Time	t_{INTND}	80	100	120	μs	²⁾ between consecutive pulses	P_11.2.4
Pulse in case of pending INTN	t_{INTN_PULSE}	4	5	6	ms	²⁾ between consecutive pulses	P_11.2.5
SDM Select; Pin INTN							
Config Pull-up Resistance	R_{SDM}	30	60	100	k Ω	$V_{INTN} = 5\text{ V}$	P_11.2.6
Config Select Filter Time	t_{SDM_F}	50	64	80	μs	²⁾	P_11.2.7

1) Output Voltage Value also determines device configuration during Init Mode.

2) Not subject to production test, tolerance defined by internal oscillator tolerance.

11 Gate Drivers

The TLE9564QX integrates six floating gate drivers capable of controlling a wide range of N-channel MOSFETs. They are configured as three high-sides and three low-sides, building three half-bridges.

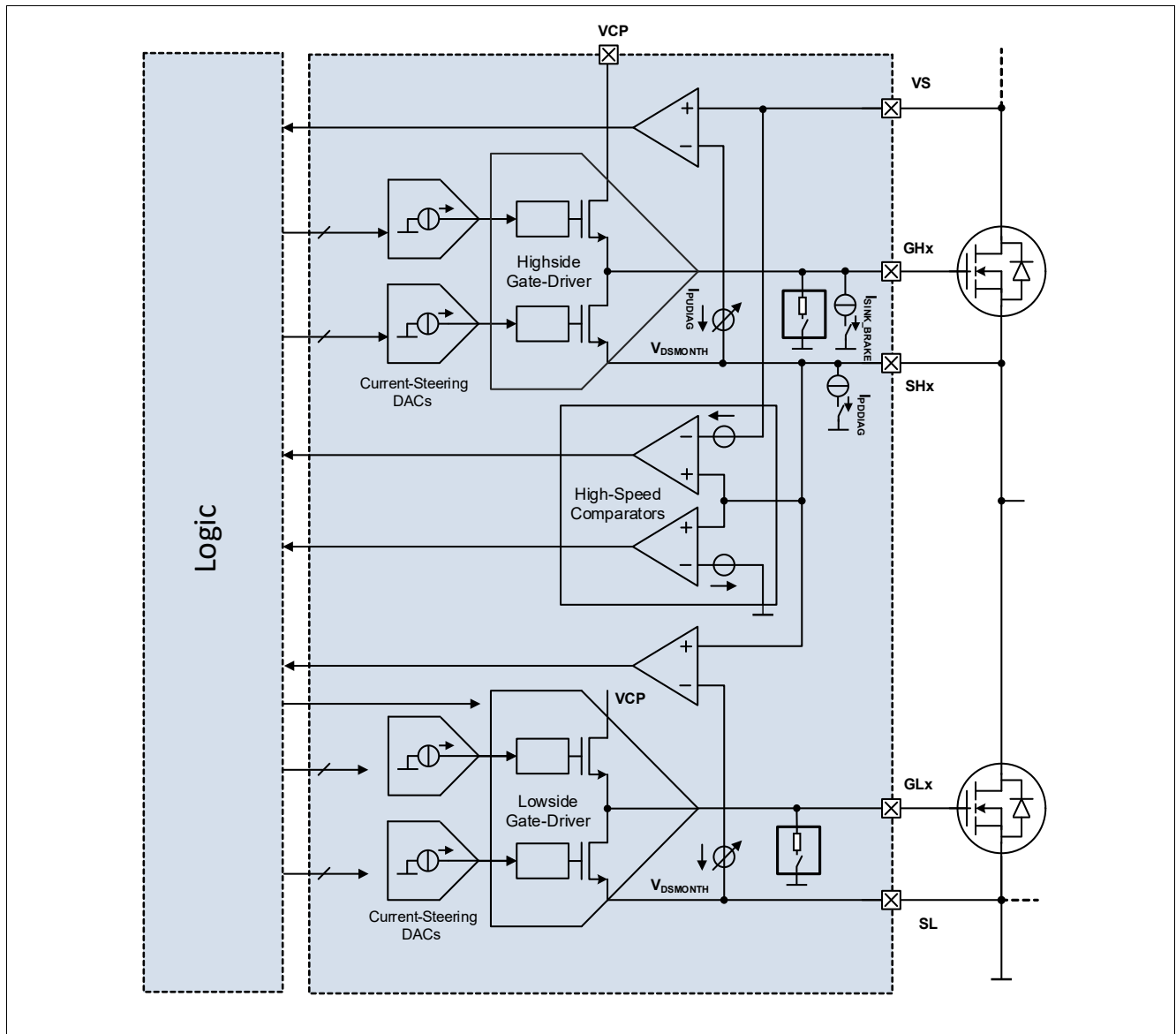

Figure 35 Half-bridge gate driver - Block diagram

This section describes the MOSFET control in static activation and during PWM operation.

Note: PWMx mentioned in this chapter refer to the PWMx pins and signal used by the bridge driver to control the external MOSFETs.

Note: In this chapter PWMx **do not refer** to the internal PWM generators used to control the internal high-side switches HSx.

11.1 MOSFET control

Depending on the configuration bits HBxMODE[1:0] (refer to **HBMODE**), **CPEN**, each high-side and low-side MOSFETs can be:

Gate Drivers

- Kept off with the passive discharge.
- Kept off actively.
- Activated (statically, no PWM, HBx_PWM_EN = 0).
- Activated in PWM mode (HBx_PWM_EN = 1).

Refer to [Table 19](#) for details.

Table 19 Half-bridge mode selection

CPEN	HBxMODE[1:0] ¹⁾	Configuration of HSx/LSx ¹⁾
CPEN = 0	Don't care	All MOSFETs are kept off by the passive discharge
CPEN = 1	00 _B	HBx MOSFETs are kept off by the passive discharge
CPEN = 1	01 _B	LSx MOSFET is ON, HSx MOSFET is actively kept OFF
CPEN = 1	10 _B	HSx MOSFET is ON, LSx MOSFET is actively kept OFF
CPEN = 1	11 _B	LSx and HSx MOSFETs are actively kept OFF with IHOLD

1) x = 1 ... 3

11.2 Static activation

In this section, we consider the static activation of the high-side and low-side MOSFET of the half-bridge x: HBx_PWM_EN = 0 (in [ST_ICHG](#)) and CPEN = 1.

The low-side or high-side MOSFET of HBx is statically activated (no PWM) by setting HBxMODE[1:0] to respectively (0,1) or (1,0).

The configured active cross-current protection and the Drain-Source overvoltage blank times for the Half-Bridge x are noted $t_{\text{HBxCCP ACTIVE}}$ and $t_{\text{HBxBLANK ACTIVE}}$.

The charge and discharge currents applied to the static controlled Half-Bridge x are noted ICHGSTx ([ST_ICHG](#)).

IHARDOFF is the maximum current that the gate drivers can sink (150 mA typ.). This current is used to keep a MOSFET off, when the opposite MOSFET of the same half-bridge is being turned on. This feature reduces the risk of parasitic cross-current conduction.

ICHGSTx is the current sourced, respectively sunk, by the gate driver to turn-on the high-side x or low-side x. ICHGSTx is configured in the control register [ST_ICHG](#).

Table 20 Static charge currents

ICHGSTx[3:0]	Nom. charge current [mA]	Nom. discharge current [mA]	Max. deviation to typ. values
0000 _B	0.5 (I_{CHG0})	0.5 (I_{DCHG0})	+/- 60%
0001 _B	1.8 (I_{CHG4})	1.8 (I_{DCHG4})	+/- 60 %
0010 _B	4.7 (I_{CHG8})	4.7 (I_{DCHG8})	+/- 60 %
0011 _B	9.4 (I_{CHG12})	9.4 (I_{DCHG12})	+/- 60 %
0100 _B	15.3 (I_{CHG16})	15.1 (I_{DCHG16})	+/- 40 %
0101 _B	23 (I_{CHG20})	22.5 (I_{DCHG20})	+/- 40 %

Gate Drivers

Table 20 Static charge currents (cont'd)

ICHGSTx[3:0]	Nom. charge current [mA]	Nom. discharge current [mA]	Max. deviation to typ. values
0110 _B	31.6 (I_{CHG24})	30.9 (I_{DCHG24})	+/- 40 %
0111 _B	41.6 (I_{CHG28})	40.8 (I_{DCHG28})	+/- 40%
1000 _B	52.5 (I_{CHG32})	51.5 (I_{DCHG32})	+/- 30 %
1001 _B	63.6 (I_{CHG36})	62.4 (I_{DCHG36})	+/- 30 %
1010 _B	75.2 (I_{CHG40})	73.7 (I_{DCHG40})	+/- 30 %
1011 _B	87.1 (I_{CHG44})	85.5 (I_{DCHG44})	+/- 30 %
1100 _B	99.5 (I_{CHG48})	97.7 (I_{DCHG48})	+/- 30 %
1101 _B	112.2 (I_{CHG52})	110.8 (I_{DCHG52})	+/- 30 %
1110 _B	125.3 (I_{CHG56})	124.5 (I_{DCHG56})	+/- 30 %
1111 _B	139 (I_{CHG60})	138.7 (I_{DCHG60})	+/- 30 %

IHOLD is the hold current used to keep the gate of the external MOSFETs in the desired state. This parameter is configurable with the IHOLD control bit in **GENCTRL**.

If the control bit IHOLD = 0:

- A MOSFET is kept ON with the current I_{CHG15} .
- A MOSFET is kept OFF with the current I_{DCHG15} .

If the control bit IHOLD = 1:

- A MOSFET is kept ON with the current I_{CHG20} .
- A MOSFET is kept OFF with the current I_{DCHG20} .

11.2.1 Static activation of a high-side MOSFET

Turn-on with cross-current protection

If LSx is ON (HBxMODE[1:0] = 01_B), before the activation of HSx (HBxMODE[1:0] = 10_B) then the high-side MOSFET is turned on after a cross-current protection time (refer to **Figure 36**):

- After the CSN rising edge and for the duration $t_{HBxCCP\ ACTIVE}$:
 - The high-side MOSFET is kept OFF with the current -ICHGSTx.
 - The gate of the low-side MOSFET is discharged with the current -ICHGSTx.
- At the end of $t_{HBxCCP\ ACTIVE}$ and for the duration $t_{HBxBLANK\ ACTIVE} + t_{FVDS}$:
 - The gate of the high-side MOSFET is charged with the current ICHGSTx.
 - Low-side MOSFET is kept OFF with the current -IHARDOFF (hard off phase).
- At the end of t_{FVDS} :
 - The drive current of the high-side MOSFET is reduced to IHOLD.
 - The drive current of the low-side MOSFET is set to -IHOLD.

Gate Drivers

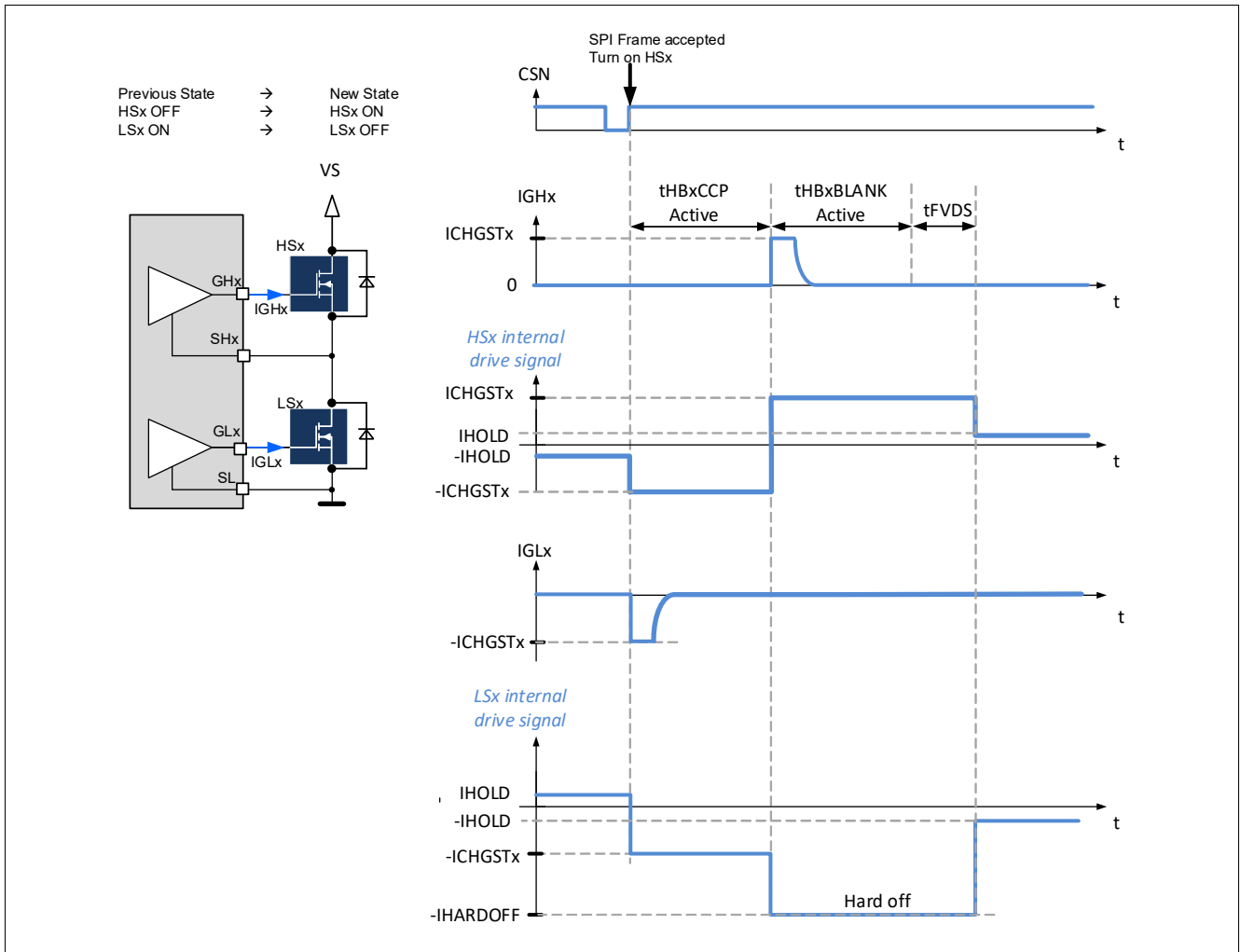

Figure 36 Turn-on of a high-side MOSFET with cross-current protection

Note: The CSN rising edge must be synchronized with the device logic. Therefore SPI commands are executed with a delay of up to 3 μ s after the CSN rising edge.

Gate Drivers

Turn-on without cross-current protection

If LSx is OFF ($HBxMODE[1:0] = 11_B$), before the activation of HSx ($HBxMODE[1:0] = 10_B$), then the high-side MOSFET is turned on without cross-current protection (refer to **Figure 37**):

- right after the CSN rising edge and for a duration $t_{HBxBLANKACTIVE} + t_{FVDS}$:
 - The gate of the high-side MOSFET is charged with the current $ICHGSTx$.
 - The low-side MOSFET is kept OFF with the current $-IHARDOFF$.
- At the end of t_{FVDS} :
 - The drive current of the high-side MOSFET is reduced to $IHOLD$.
 - The drive current of the low-side MOSFET is set to $-IHOLD$.

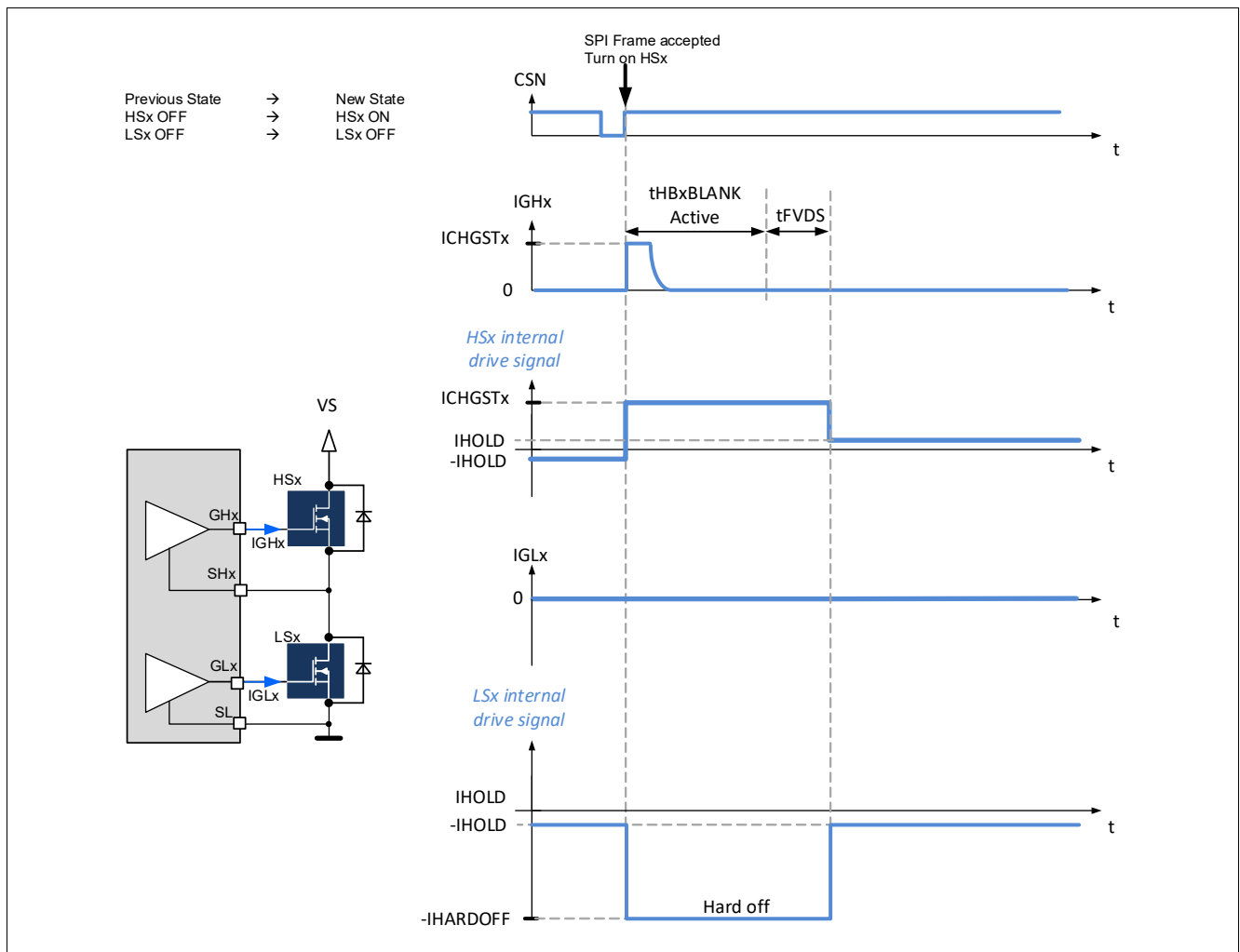

Figure 37 Turn-on of a high-side MOSFET without cross-current protection

Note: The CSN rising edge must be synchronized with the device logic. Therefore SPI commands are executed with a delay of up to 3 μ s after the CSN rising edge.

Gate Drivers

11.2.2 Static activation of a low-side MOSFET

The description of the static activation of a low-side x differs from the description of [Chapter 11.2.1](#) only by exchanging high-side x and low-side x.

11.2.3 Turn-off of the high-side and low-side MOSFETs of a half-bridge

When the TLE9564QX receives a SPI command to turn-off both the high-side and low-side MOSFETs of the half-bridge x ($HBxMODE[1:0] = (0,0)$ or $(1,1)$):

- The gate of HSx and LSx are discharged with the current $-ICHGSTx$ for the duration $t_{HBxCCP ACTIVE}$ ([Figure 38](#)).
- At the end of $t_{HBxCCP ACTIVE}$, the drive current of HSx and LSx are reduced to $-IHOLD$.

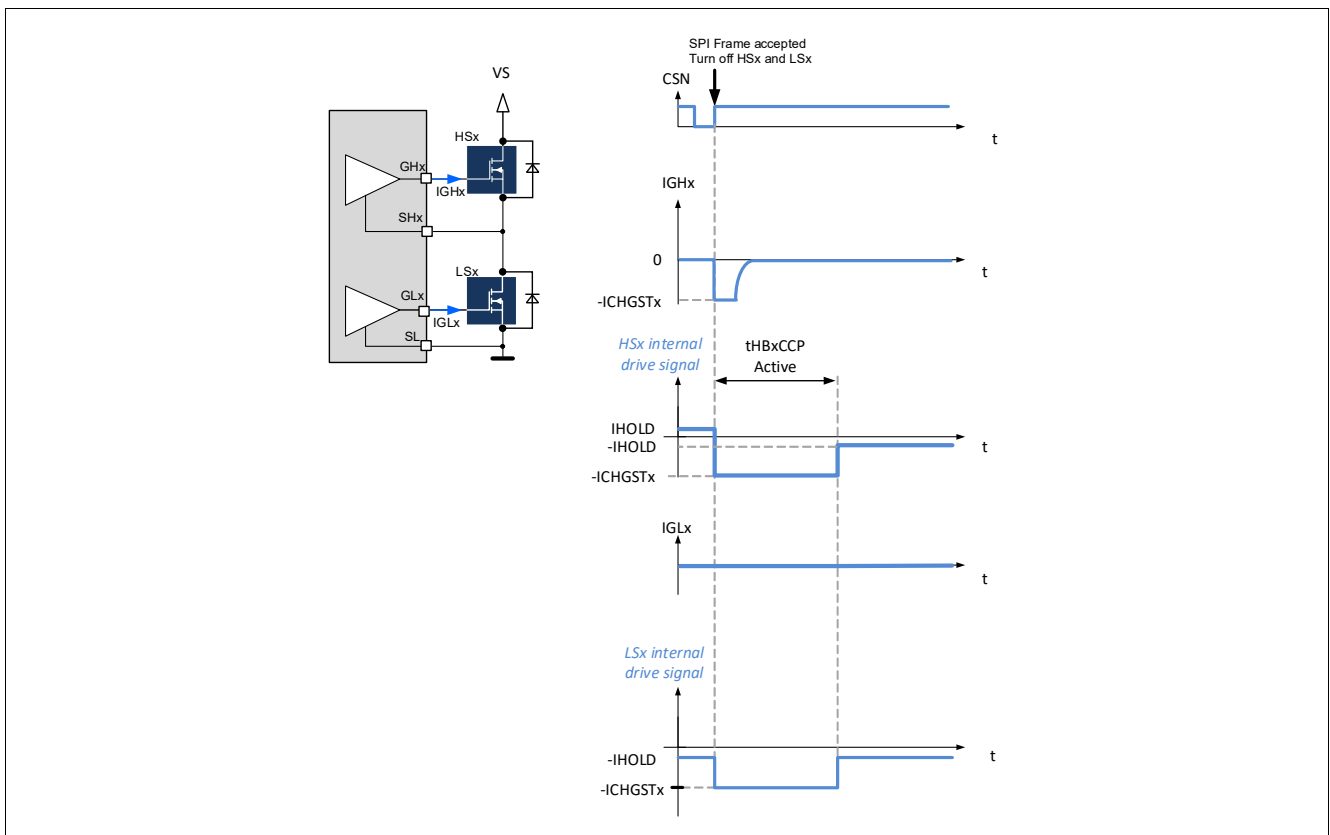

Figure 38 Turn-off of the high-side and low-side MOSFETs of a half-bridge

Note: The CSN rising edge must be synchronized with the device logic. Therefore SPI commands are executed with a delay of up to $3 \mu s$ after the CSN rising edge.

Gate Drivers

11.3 PWM operation

The half-bridge can be controlled in PWM using either three or six PWM inputs.

The TLE9564QX offers the possibility to detect the active and the freewheeling (FW) MOSFET in each half-bridge.

11.3.1 Determination of the active and freewheeling MOSFET

If $EN_GEN_CHECK = 1$, right before each MOSFET activation, the device detects which MOSFET of the half-bridge is the active MOSFET and which MOSFET is the free-wheeling (FW) MOSFET:

- If $VSHx > VS - VSHH$: The high-side MOSFET is the FW MOSFET and the low-side MOSFET is the active MOSFET.
- If $VSHx < VSHL$: Then the low-side MOSFET is the FW MOSFET and the high-side MOSFET is the active MOSFET.
- If $VSHL < VSHx < VSHH$: No clear distinction between the active FW MOSFET and the active MOSFET. The next MOSFET to be turned on is turned on as if it was the active MOSFET.

If $EN_GEN_CHECK = 0$, the detection of the active and FW MOSFET is disabled. The PWM MOSFET is considered as the active MOSFET.

Figure 39 shows the detection of the active and of the FW MOSFET.

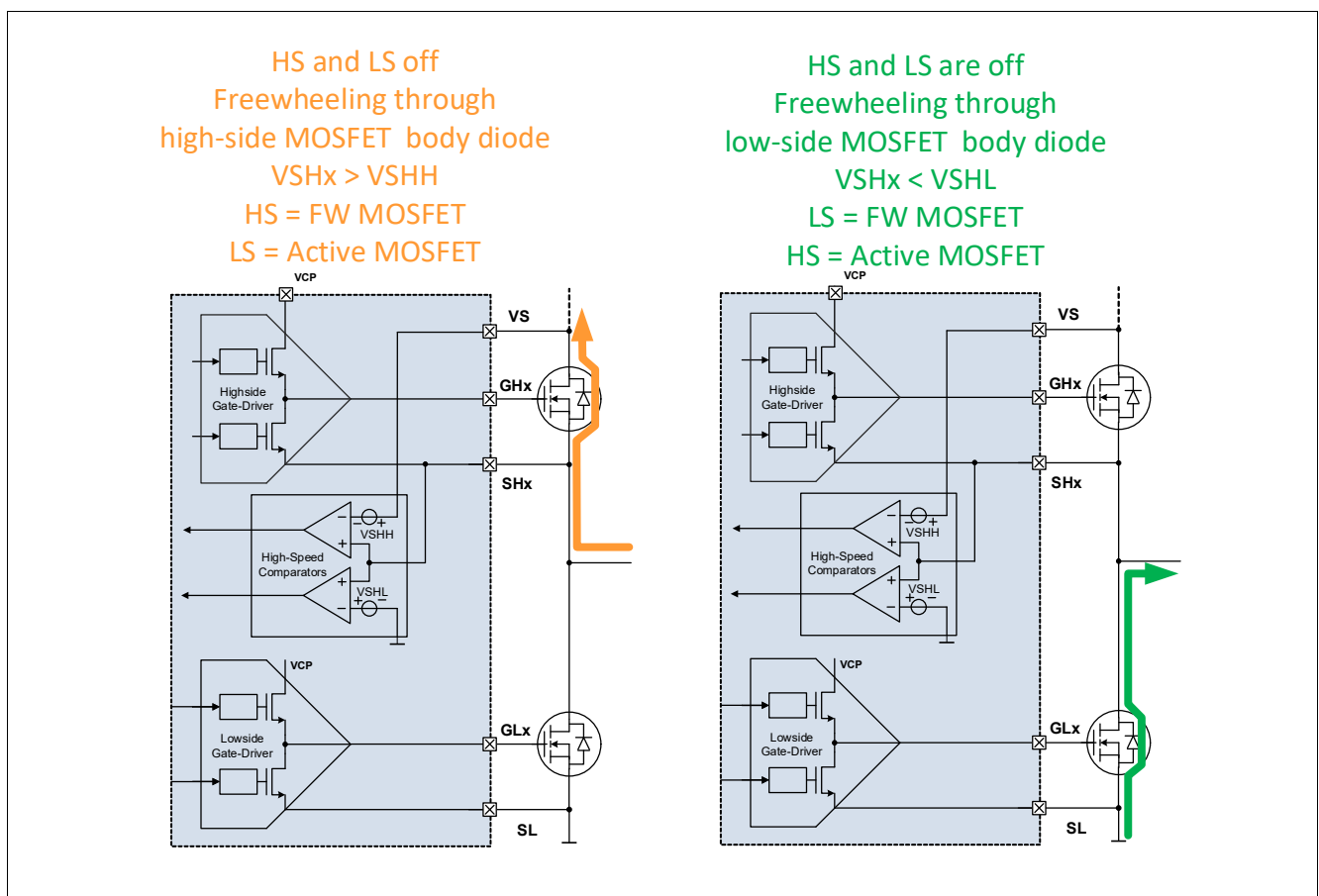

Figure 39 Detection of the active and FW MOSFET - Principle

11.3.2 Configurations in PWM mode

The following sections describe the different control schemes in PWM mode.

Gate Drivers

Active gate control (AGC)

The active gate control is configured by the control bits AGC[1:0]. The control scheme during the pre-charge and pre-discharge phases of:

- The active MOSFET (**EN_GEN_CHECK**=1).
- The PWM MOSFET (**EN_GEN_CHECK**=0).

can be selected.

The following settings are possible:

- Adaptive gate control (AGC[1:0] = (1,0) or (1,1), see **GENCTRL**): In this mode a pre-charge current and a pre-discharge current are applied to the gate of the controlled MOSFET. These currents are used to regulate effectively the turn-on and turn-off delays to the respective target values.
- No adaptive gate control (AGC[1:0] = (0,0)): in this mode, the pre-charge and pre-discharge phases are deactivated.
- No adaptive gate control (AGC[1:0] = (0,1)). In this mode:
 - During the pre-charge phase, the MOSFET is discharged with the configured current IPCHGINIT (**HB_PCHG_INIT**).
 - During the pre-discharge phase, the MOSFET is discharged with the configured current IPDCHGINIT (**HB_PCHG_INIT**).

*Note: It is recommended to configure $tPCHG_x < tHB_xBLANK$ Active and $tPDCHG_x < tHB_xCCP$ Active (Refer to **TPRECHG** and **CCP_BLK**) independently from the AGC settings.*

Active free-wheeling (AFW)

The active free-wheeling is activated for HBx if these conditions are fulfilled:

- AFWx = 1 (**HBMODE**)
- HBx_PWM_EN = 1 (**HBMODE**)
- **PWM_NB** = 0

If AFWx = 1, a cross-current protection time is applied to HBx (set by **CCP_BLK**) during the PWM operation.

If AFWx = 0, no cross current protection is applied to HBx during the PWM operation.

The active free-wheeling reduces the power dissipation of the free-wheeling MOSFET. If an active MOSFET is OFF, the opposite MOSFET of the same half-bridge is actively turned on. Refer to **Figure 43** and **Figure 44**.

Gate Drivers

Post-charge

A post-charge is initiated if POCHGDIS is set to 0 (**GENCTRL**) to reach the minimum MOSFET $R_{ds(on)}$:

- **POCHGDIS** = 0: After the charge phase, the control signal for the charge current of LSx is increased by one current step at every bridge driver clock cycle (**BDFREQ**) to ICHGMAXx. Refer to **Figure 40**
- **POCHGDIS** = 1: The post-charge phase is disabled. The charge current is kept to the ICHGx

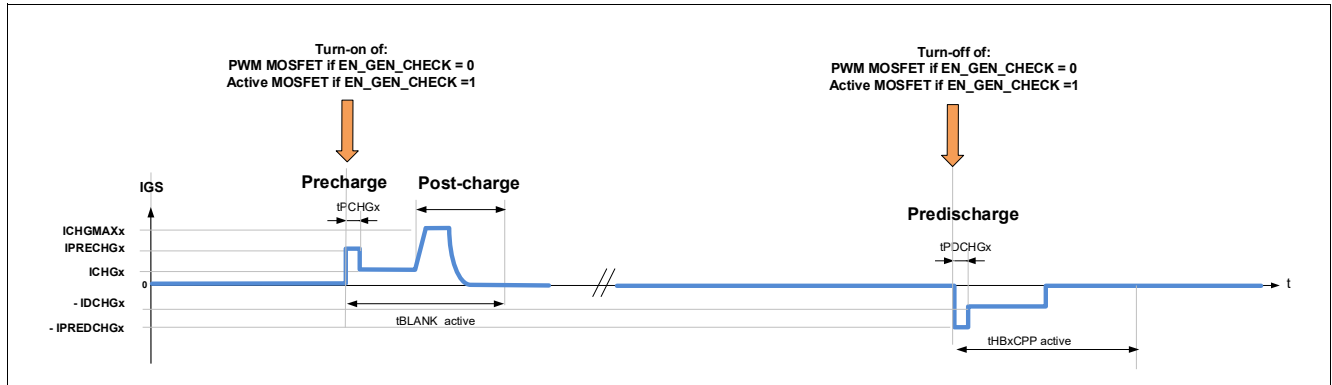

Figure 40 PWM overview - AGC = 10_B or 11_B, POCHGDIS=0 (post-charge enabled)

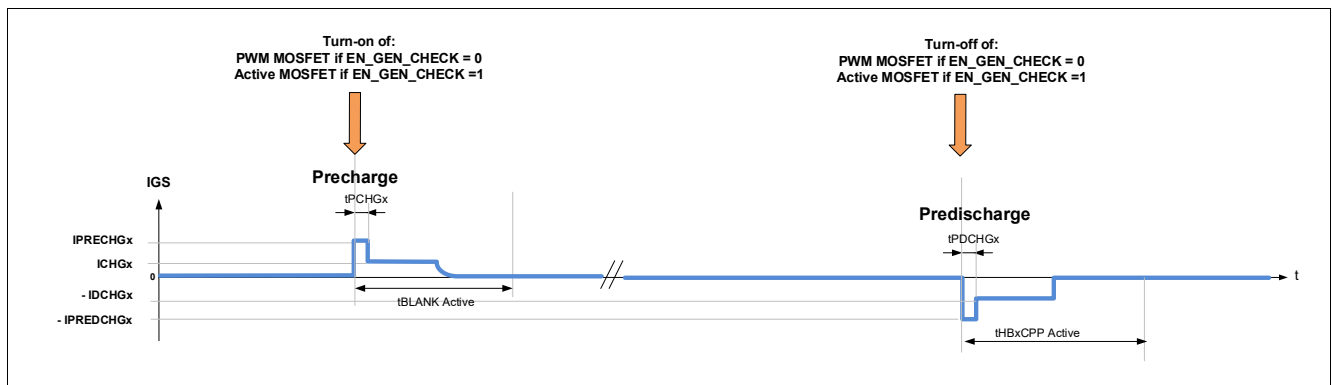

Figure 41 PWM overview - AGC = 10_B or 11_B, POCHGDIS=1 (post-charge disabled)

Table 21 Abbreviations for adaptive turn-on and turn-off phases in PWM configuration

Abbreviation	Definition
Suffix x	Related to the half-bridge x.
VGS_HSx	Gate-Source voltage of high-side MOSFET x.
IGS_HSx	Gate current of high-side MOSFET x. IGS_HSx is positive when the current flows out of GHx.
VGS_LSx	Gate-Source voltage of low-side MOSFET x.
IGS_LSx	Gate current of low-side MOSFET x. IGS_LSx is positive when the current flows out of GLx.
tPWM_SYNCH	Synchronization delay between external and internal PWM signal.
tHBxCCP ACTIVE	Active cross-current protection time of HBx. See control register CCP_BLK .
tHBxBLANK ACTIVE	Active Drain-source overvoltage blank time of HBx. See control register and CCP_BLK .
tHBxCCP FW	Freewheeling cross-current protection time of HBx. See control register CCP_BLK .

Gate Drivers

Table 21 Abbreviations for adaptive turn-on and turn-off phases in PWM configuration (cont'd)

Abbreviation	Definition
tHBxBLANK FW	Freewheeling drain-source overvoltage blank time of HBx. See control register and CCP_BLK .
PWMz	External PWM signal applied to the input pin PWMz.
ICHGMAXx	Maximum drive current of the half-bridge x during the pre-charge and pre-discharge phases. See control register HB_ICHG_MAX . IPRECHGx and IPREDCHGx are limited to ICHGMAXx.
IPRECHGx	Pre-charge current sourced by the gate driver to the active MOSFET of the half-bridge x during tPCHGx (TPRECHG). Internal and self-adaptive parameter (if AGC[1:0] = (1,0) or (1,1), GENCTRL). IPRECHGx is clamped between I_{CHG0} (0.5 mA typ.) and ICHGMAXx.
IPCHGINITx	Initial value of IPRECHGx. Refer to HB_PCHG_INIT .
IPREDCHGx	Pre-discharge-current sunk by the gate driver mapped to the half-bridge x during tPDCHGx. Internal and self-adaptive parameter (if AGC[1:0] = (1,0) or (1,1), GENCTRL). IPREDCHGx is clamped between I_{DCHG0} (0.5 mA typ.) and ICHGMAXx.
IPDCHGINITx	Initial value of IPREDCHGx. Refer to HB_PCHG_INIT .
ICHGx	Current sourced by the gate driver to the active MOSFET of the half-bridge x during the charge phase. See control register HB_ICHG .
IDCHGx	Current sunk by the gate driver to turn-off the active MOSFET of the half-bridge x during the discharge phase. See control register HB_ICHG .
ICHGFWx	Current sourced or sunk by the gate driver to turn on / turn off the freewheeling MOSFET of the half-bridge x. See control register HB_ICHG .
tPCHGx	Duration of the pre-charge phase of half-bridge x. tPCHGx is configurable by SPI. See control register TPRECHG .
tPDCHGx	Duration of the pre-discharge phase of half-bridge x. tPDCHGx is configurable by SPI. See control register TPRECHG .
tDONx	Turn-on delay of the active MOSFET of HBx.
tDOFFx	Turn-off delay of the active MOSFET of HBx.
IHOLD	Hold current sourced or sunk by the gate driver to keep the MOSFET in the desired state. See IHOLD control bit in GENCTRL .
IHARDOFF	IHARDOFF is the maximum current that the gate drivers can sink. It corresponds to the discharge current when IDCHGx[5:0] = 63 _D (150 mA typ.).
TFVDS	Drain-Source overvoltage filter time. See LS_VDS .

11.3.3 PWM operation with 3 PWM inputs

Each half bridge are controlled by one input if PWM_NB = 0 (see **CSA**) and HBx_PWM_EN (see **HBMODE**):

- PWM1/CRC controls HB1
- PWM3 controls HB2
- PWM5 controls HB3

Gate Drivers

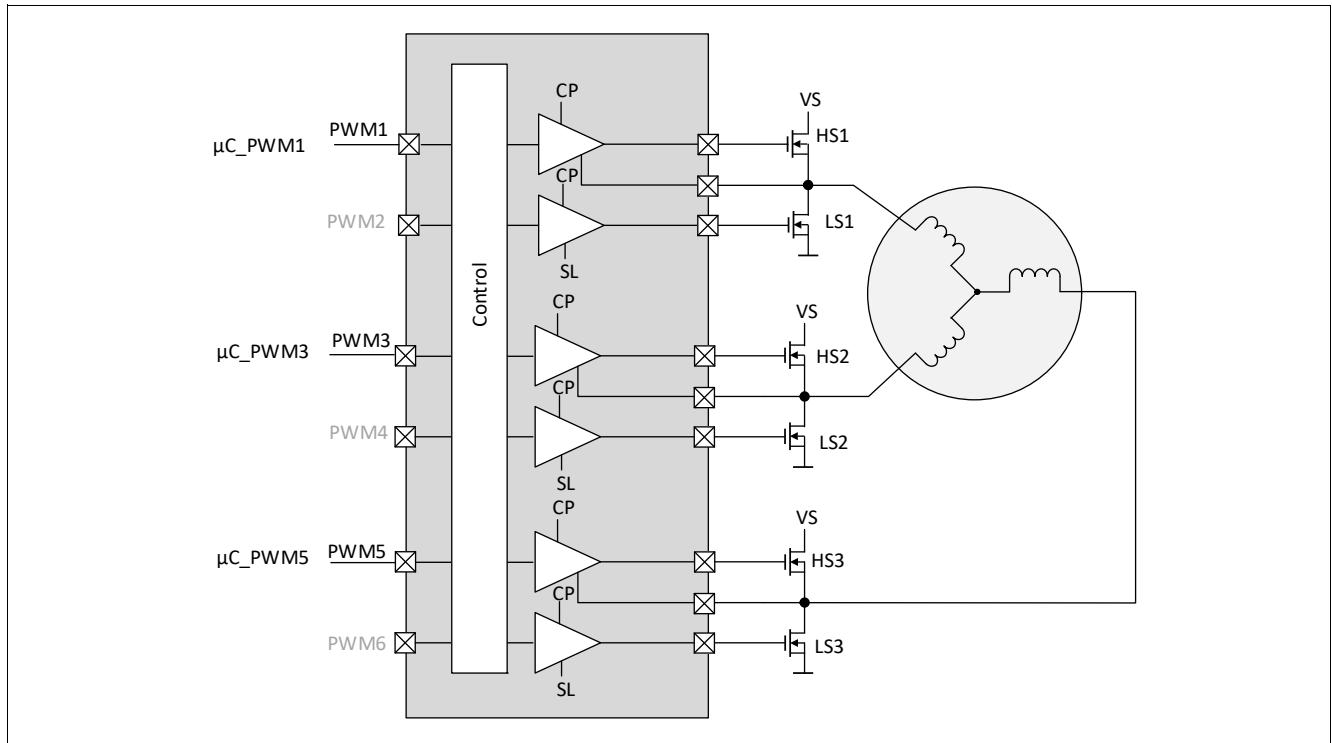

Figure 42 Half-bridge PWM control with three PWM inputs, PWM_NB = 0

Table 22 Half-bridge PWM settings with 3 PWM inputs

PWM_NB	HBxPWM_EN ¹⁾	HBxMODE ¹⁾	AFW	Half-bridge x settings ¹⁾
0	Don't care	00 _B	Don't care	LSx and HSx MOSFETs are kept OFF by the passive discharge
0	1	01 _B	0	PWM signal applied to LSx PWM signal = 1: LSx, ON, HSx OFF PWM signal = 0: LSx OFF, HS x OFF
0	1	10 _B	1	PWM signal applied to HSx PWM signal= 1: HSx, ON, LSx OFF PWM signal = 0: HSx OFF, LS x ON
0	Don't care	11 _B	Don't care	LSx and HSx MOSFETs are actively kept OFF

1) x = 1 to 3

11.3.3.1 Control signals with active free-wheeling (AFW_x = 1)

This section describes the MOSFET control signals with active freewheeling and HS PWM:

- The HS PWM MOSFET is the active MOSFET ([Chapter 11.3.3.1.1](#)).
- The HS PWM MOSFET is the free-wheeling MOSFET ([Chapter 11.3.3.1.2](#)).

11.3.3.1.1 The PWM MOSFET is the active MOSFET

This section shows the control signals of the MOSFET when the PWM is the active MOSFET.

Gate Drivers

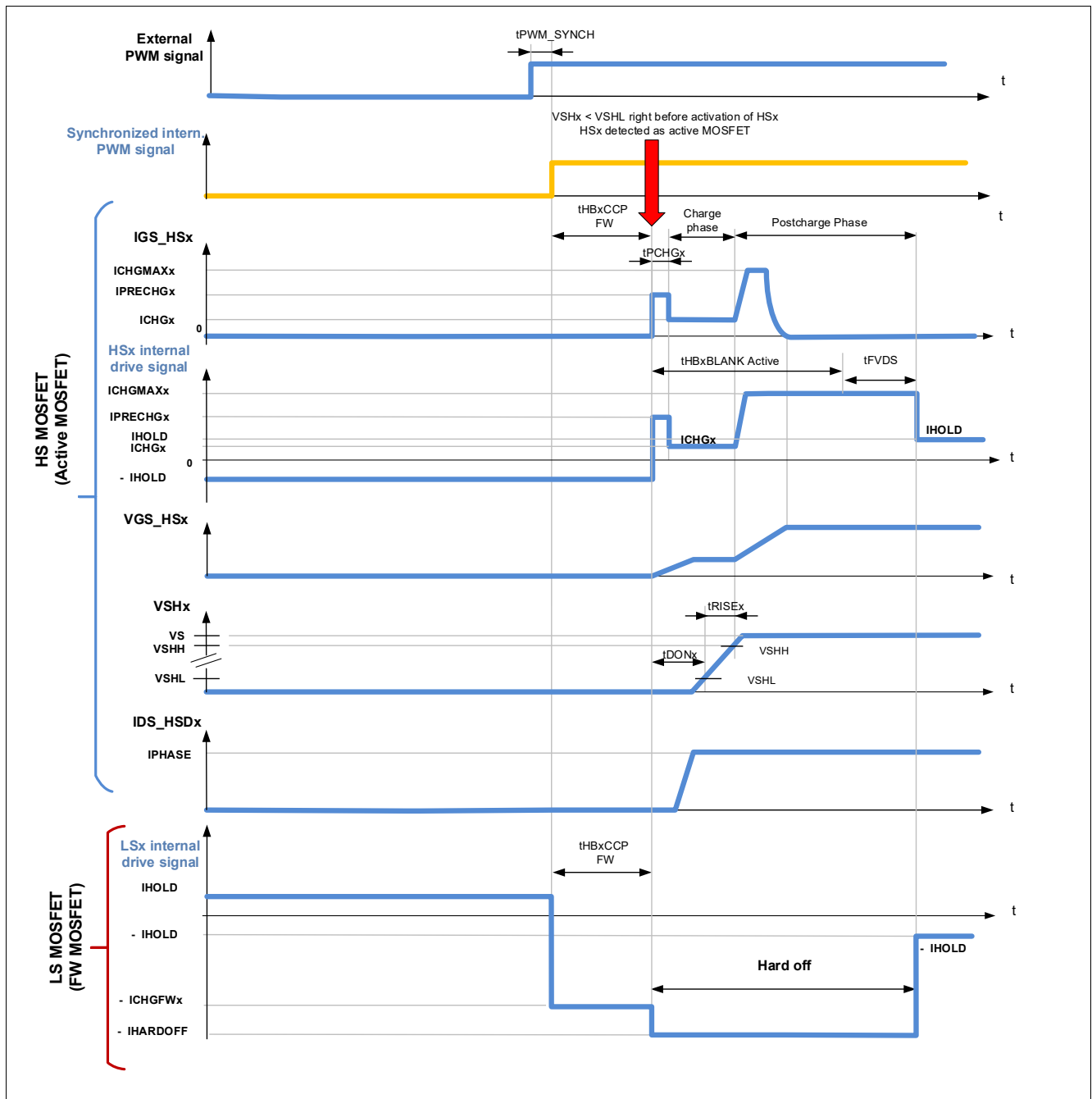

Figure 43 Turn-on of an active MOSFET in PWM mode with active gate control, HS PWM, HS as active MOSFET, LS as FW MOSFET. PWM_NB=0 (one PWM input per HB), HBxMODE = 10_B (HS PWM), AGC = 01_B or 10_B (Active Gate Control), EN_GEN_CHECK=1 (detection of active / FW MOSFET), AFWx = 1 (active freewheeling for HBx is activated)

Gate Drivers

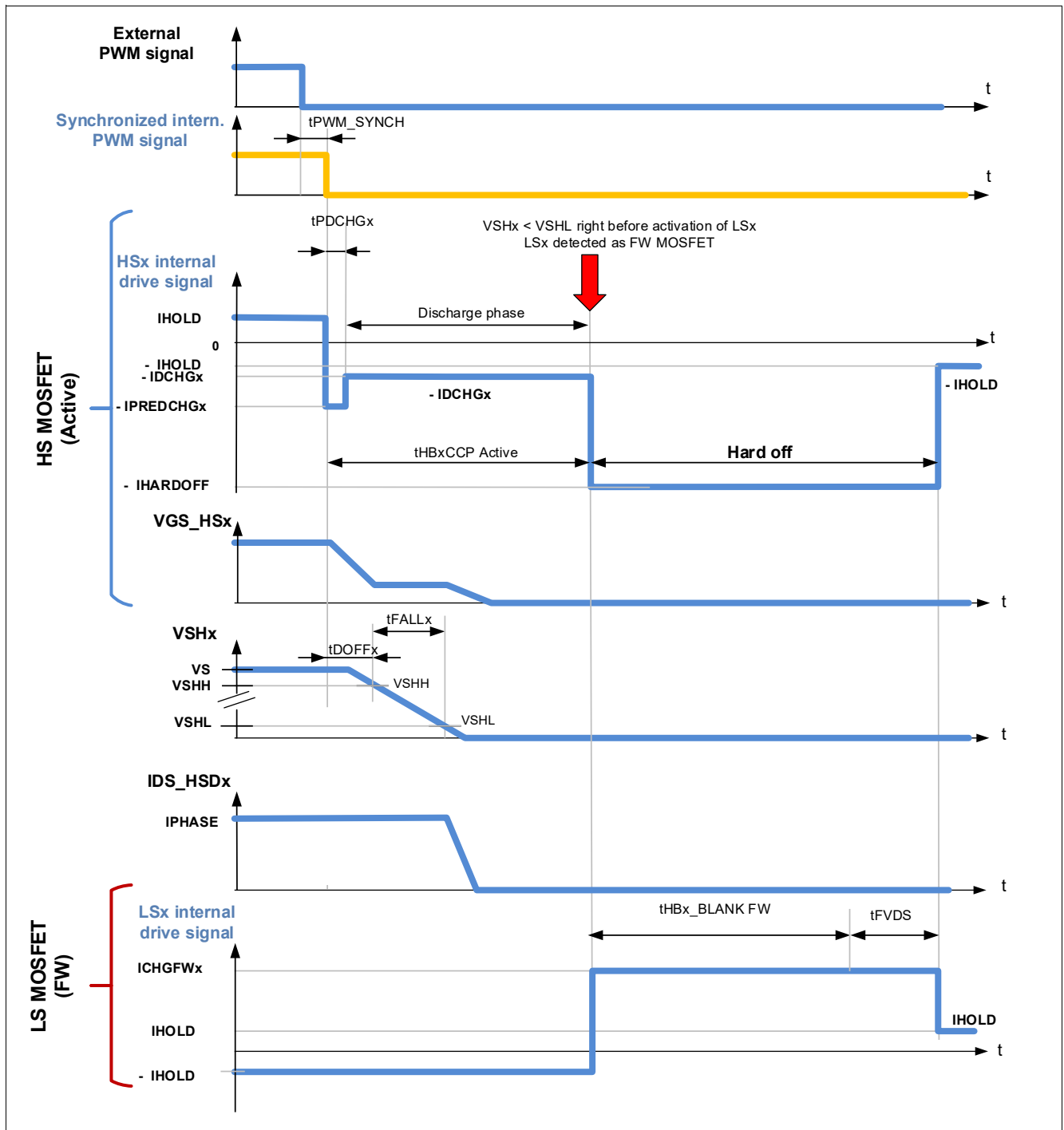

Figure 44 Turn-off of an active MOSFET in PWM mode with active gate control, HS PWM, HS as active MOSFET, LS as FW MOSFET. PWM_NB = 0 (one PWM input per HB), HBxMODE = 10_B (HS PWM), AGC = 01_B or 10_B (Active Gate Control), EN_GEN_CHECK = 1 (detection of active / FW MOSFET), AFWx = 1 (active freewheeling for HBx is activated)

Gate Drivers

11.3.3.1.2 The PWM MOSFET is the free-wheeling MOSFET

This section shows the control signals of the MOSFET when the PWM is the free-wheeling MOSFET.

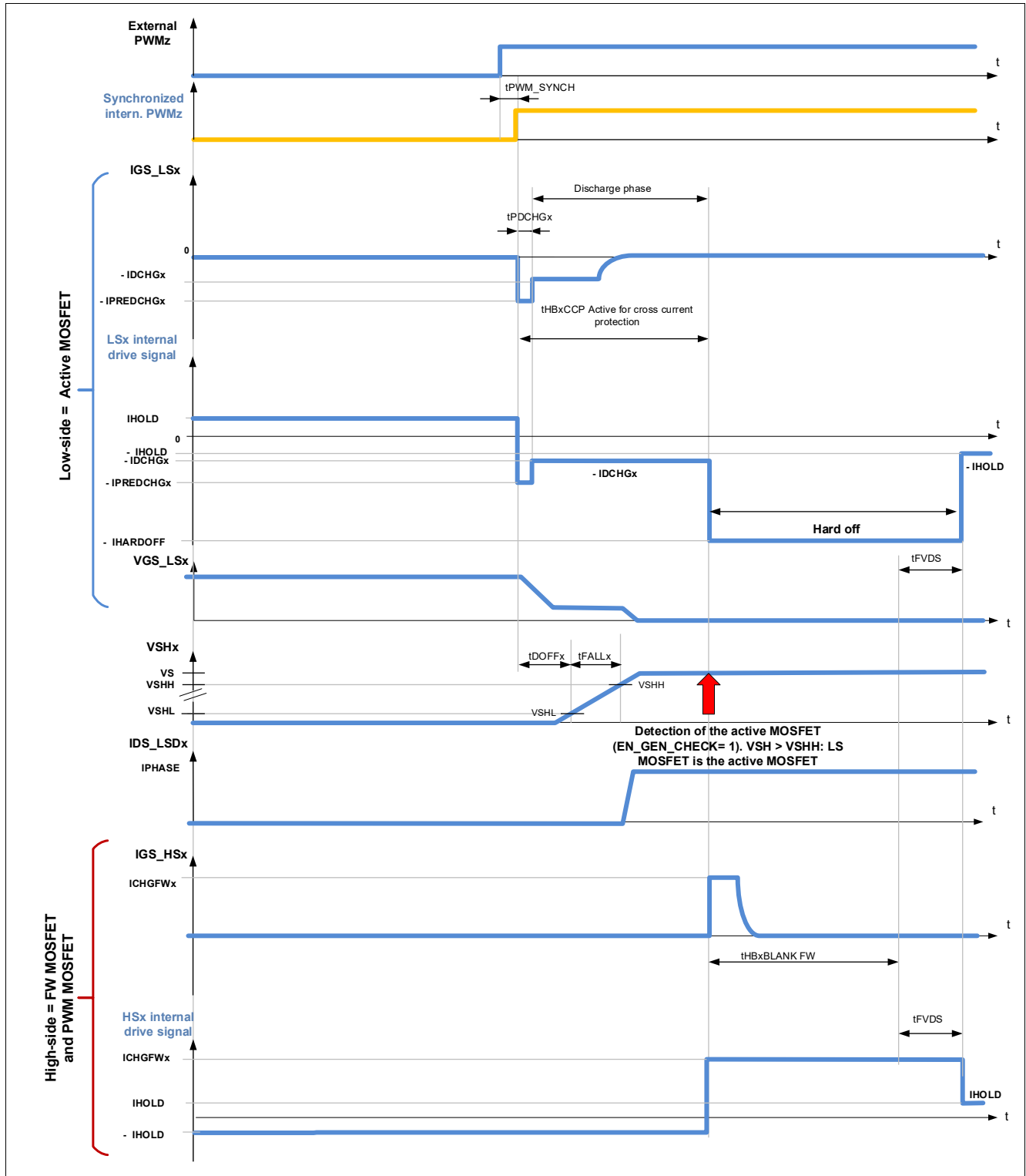

Figure 45 PWM rising edge - PWM mode with active gate control, HS PWM (HBxMODE = 10_B), LS as active MOSFET, HS as FW MOSFET. PWM_NB=0 (one PWM input per HB), AGC = 01_B or 10_B (Active Gate Control), EN_GEN_CHECK=1 (detection of active / FW MOSFET), AFWx = 1 (active freewheeling for HBx is activated)

Gate Drivers

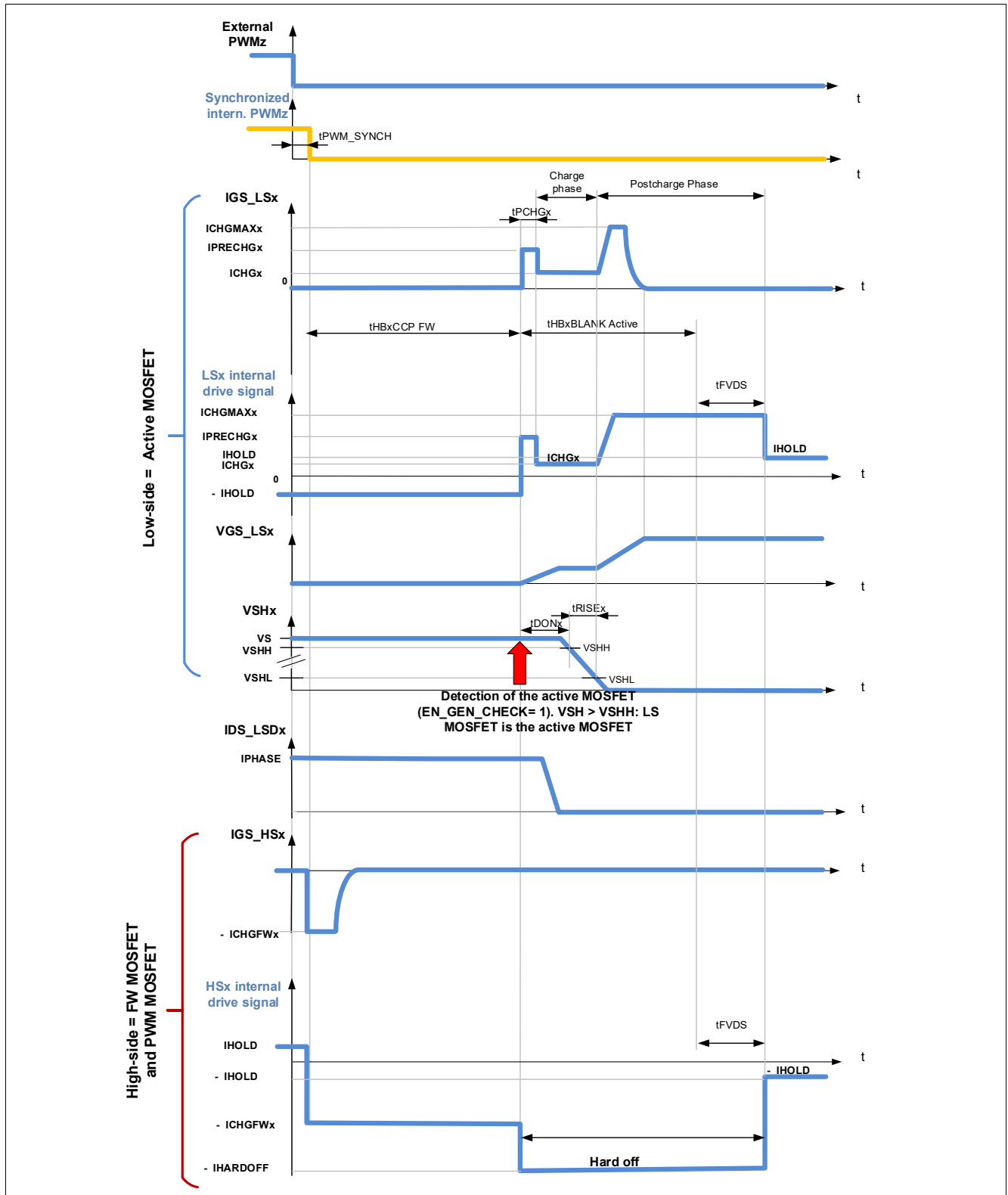

Figure 46 PWM falling edge - PWM mode with active gate control, HS PWM (HBxMODE = 10_B), LS as active MOSFET, HS as FW MOSFET. PWM_NB=0 (one PWM input per HB), AGC = 01_B or 10_B (Active Gate Control), EN_GEN_CHECK=1 (detection of active / FW MOSFET), AFWx = 1 (active freewheeling for HBx is activated)

11.3.3.2 Control signals with passive free-wheeling (AFW_x = 0)

This section describes the MOSFET control signals with active freewheeling and HS PWM:

- The HS PWM MOSFET is the active MOSFET ([Chapter 11.3.3.2.1](#)).
- The HS PWM MOSFET is the free-wheeling MOSFET ([Chapter 11.3.3.2.2](#)).

11.3.3.2.1 The PWM MOSFET is the active MOSFET

This section shows the control signals of the MOSFET when the PWM is the active MOSFET.

Gate Drivers

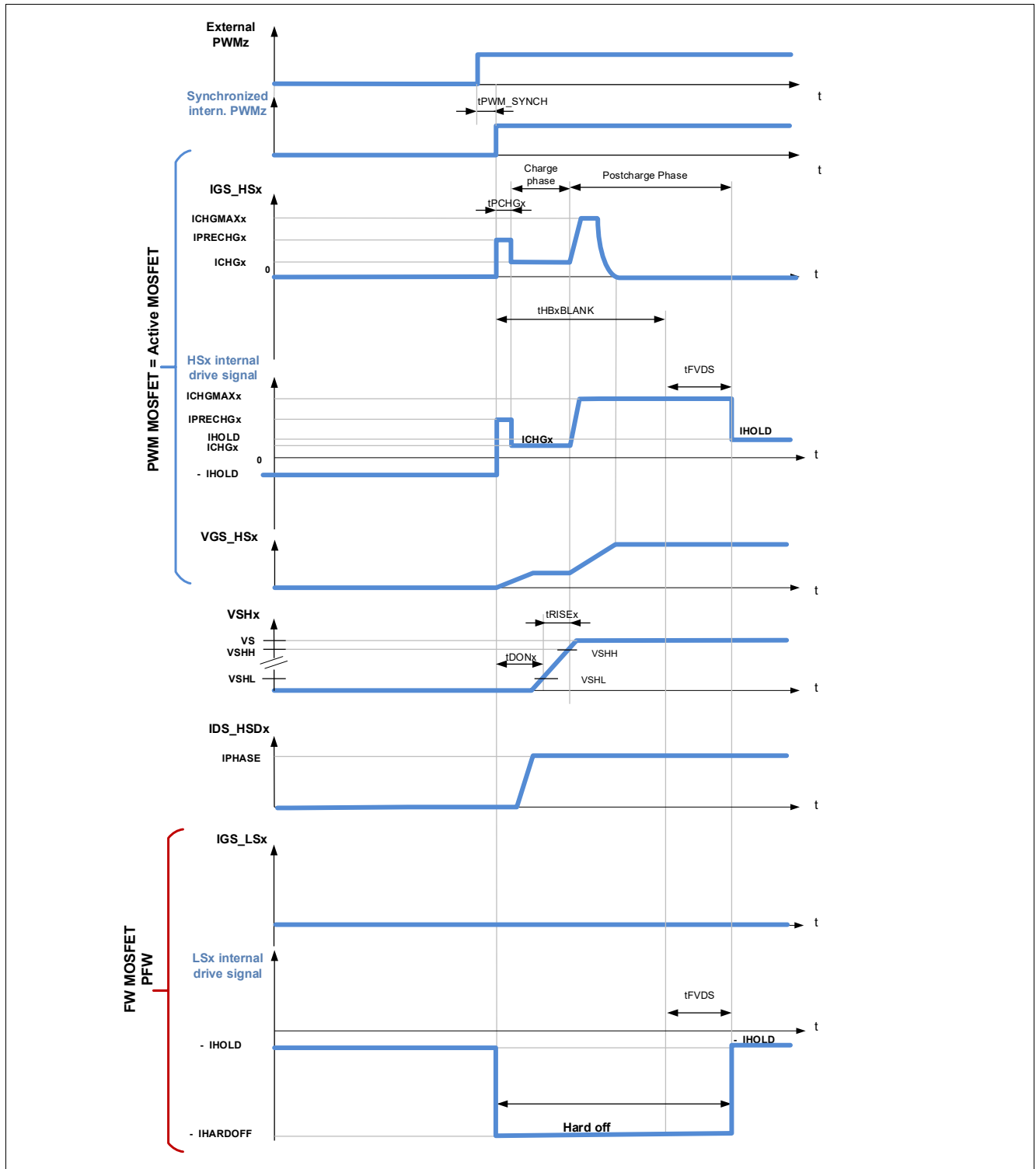

Figure 47 Adaptive turn-on with high-side PWM, $AGC[1:0] = (1,0)$ or $(1,1)$, $AFWx=0$, $POCHGDIS=0$, the PWM MOSFET is the active MOSFET. $PWM_NB=0$.

Gate Drivers

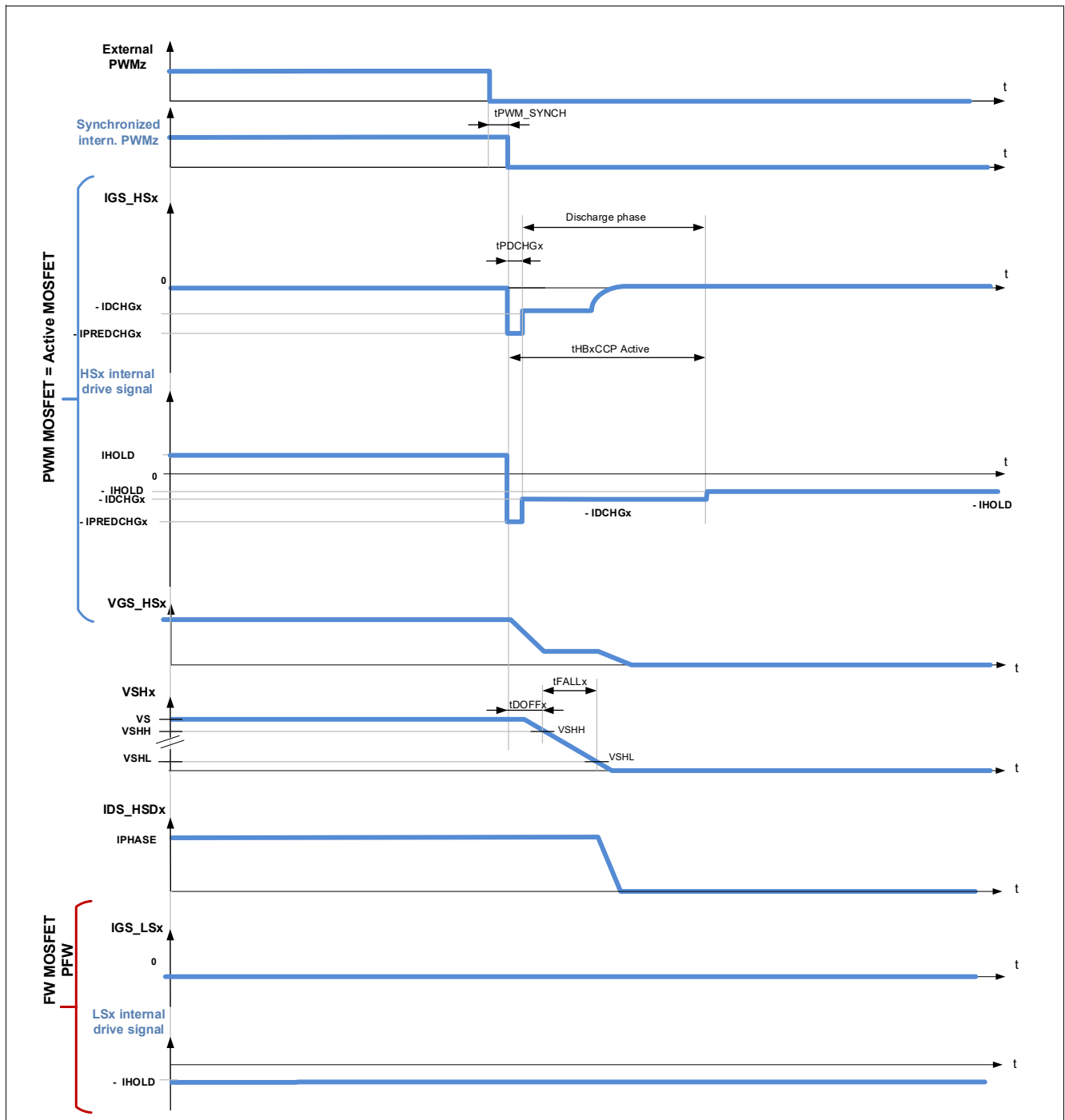

Figure 48 Adaptive turn-off with high-side PWM, AGC[1:0] = (1,0) or (1,1), AFWx=0, POCHGDIS=0, the PWM MOSFET is the active MOSFET. PWM_NB=0.

11.3.3.2.2 The PWM MOSFET is the free-wheeling MOSFET

This section shows the control signals of the MOSFET when the PWM is the free-wheeling MOSFET.

Gate Drivers

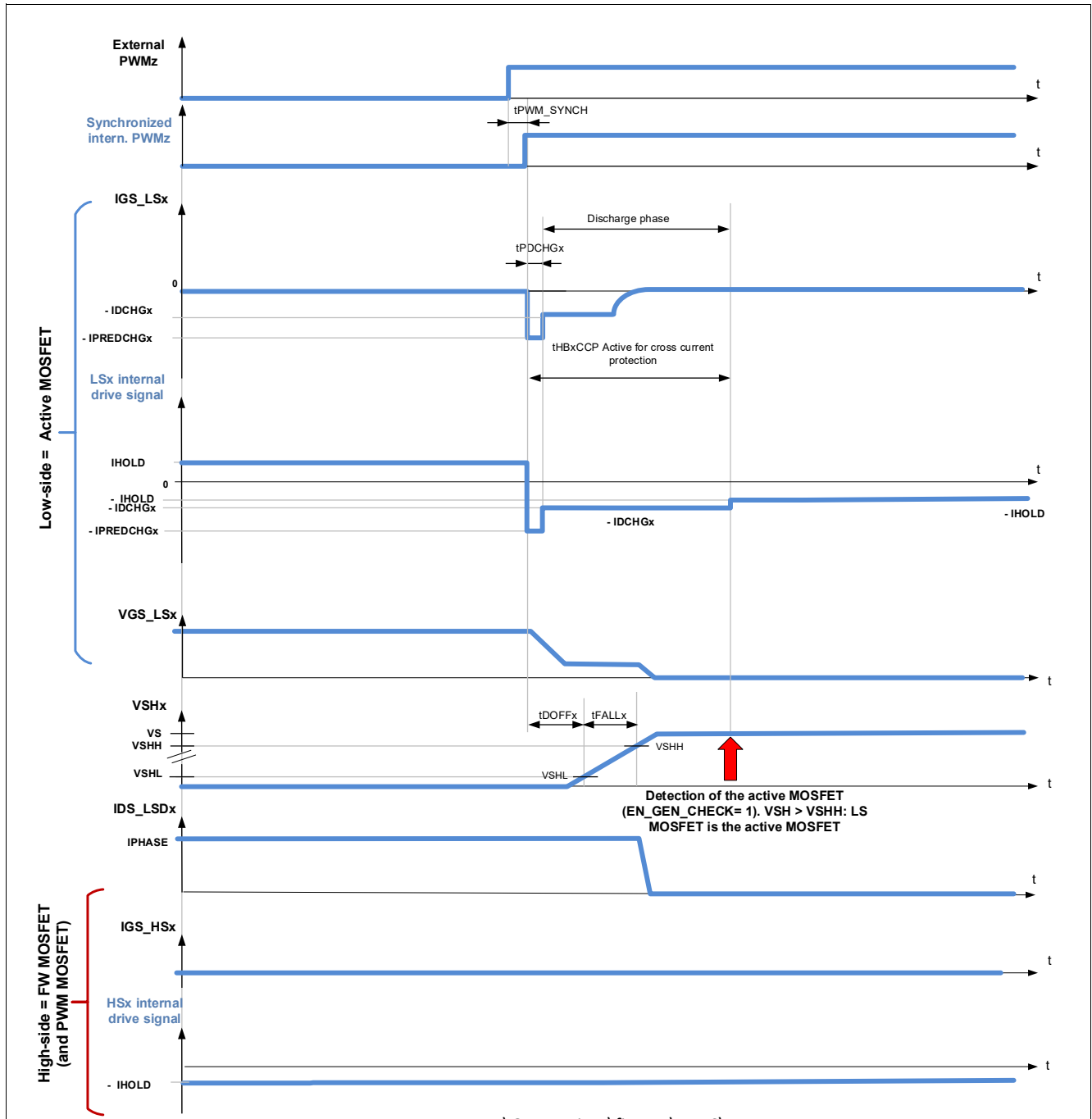

Figure 49 PWM rising edge with adaptive control, EN_GEN_CHECK = 1 with high-side PWM, AGC[1:0] = (1,0) or (1,1), AFWx=0, POCHGDIS=0. The PWM MOSFET is the FW MOSFET. PWM_NB=0.

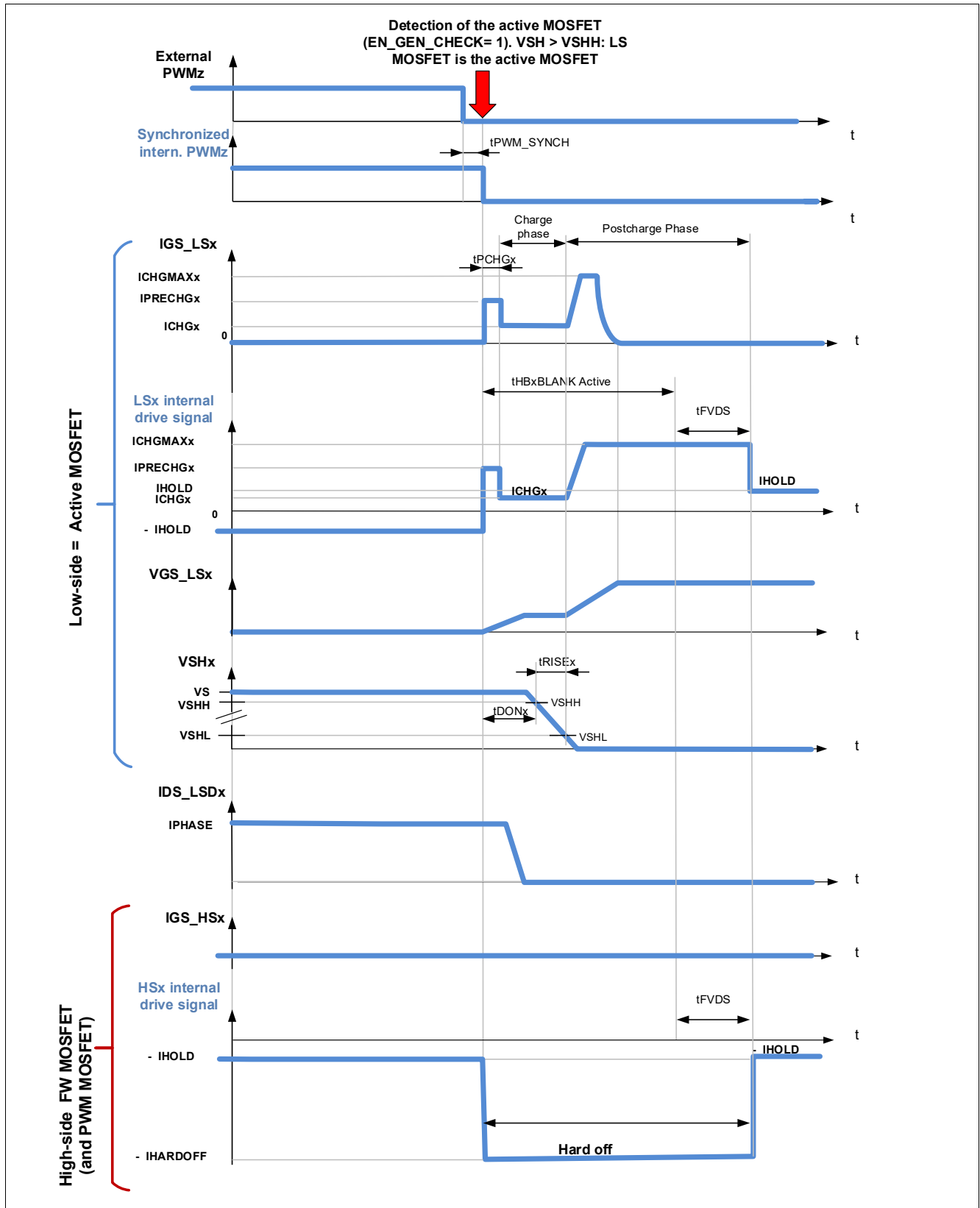

Figure 50 PWM falling edge with adaptive control, EN_GEN_CHECK = 1 with high-side PWM, AGC[1:0] = (1,0) or (1,1), AFWx=0, POCHGDIS=0. The PWM MOSFET is the FW MOSFET. PWM_NB=0.

11.3.3.3 Time modulation of pre-charge and pre-discharge times

If DEEP_ADAP =0:

Gate Drivers

- one single precharge current is applied during t_{PCHGx} to regulate T_{DON}
- one single precharge current is applied during t_{PDCHGx} to regulate T_{DOFF}

If **DEEP_ADAP** = 1 (“deep adaptation” or “time modulation”) it is possible to:

- to divide the precharge phase in two parts, during which two different precharge currents can be applied
- to divide the pre-discharge phase in two parts, during which two different precharge currents can be applied

Figure 51 describes the principle of the time modulation applied to the precharge phase. The same principle is also applied for the regulation of the pre-discharge phase.

Gate Drivers

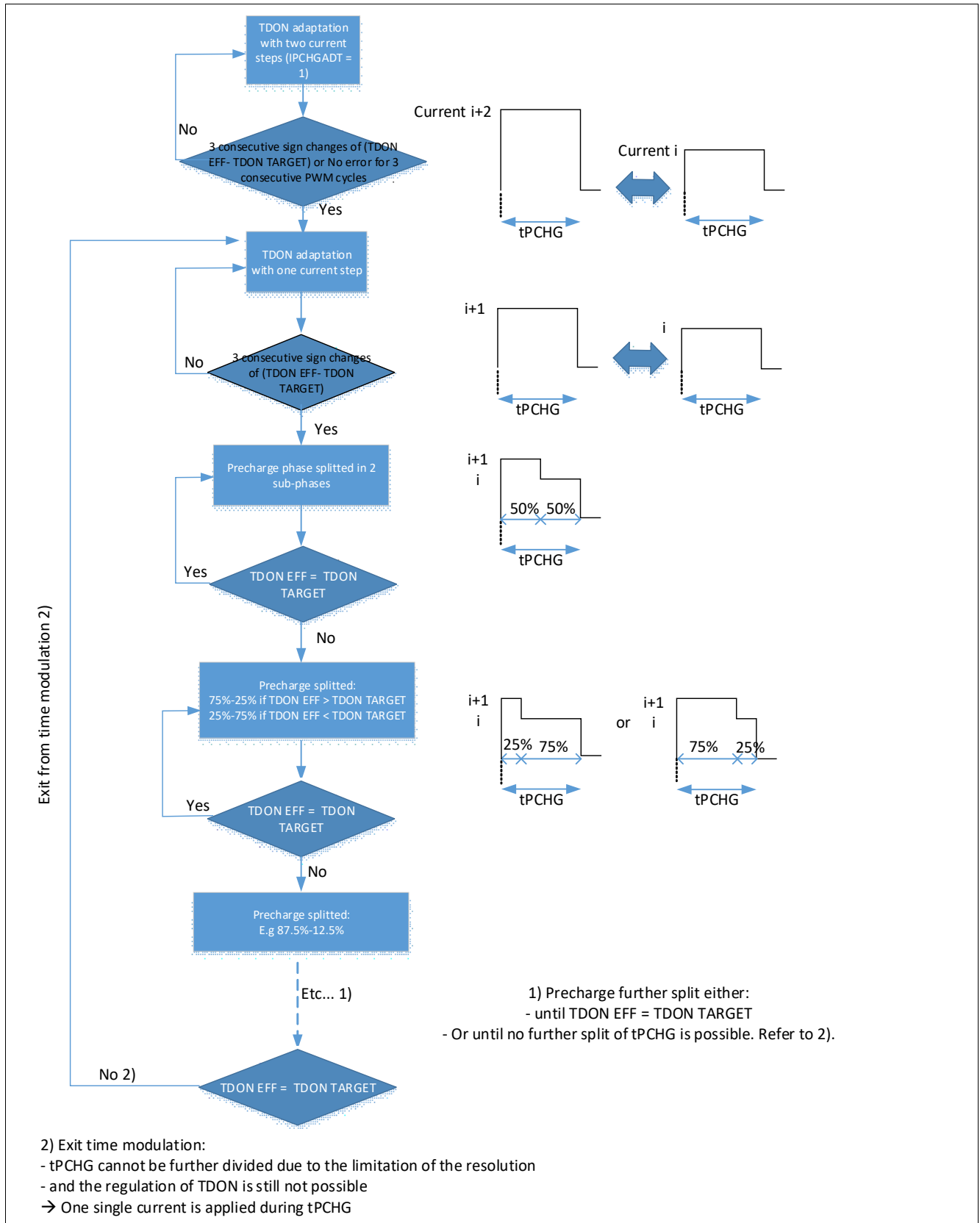

Figure 51 Principle of the time modulation of the precharge phase, DEEP_ADAP = 1, AGC = 10_B or 11_B

11.3.3.4 Operation at high and low duty cycles

In the particular cases where the on-time is shorter than t_{HBxCCP} FW or the off-time of the PWM signal is shorter than t_{HBxCCP} Active:

- No distinction between active MOSFET and FW MOSFET is possible. Therefore PWM MOSFET (selected by $HBxMODE[1:0]$) is controlled as active MOSFET.
- The MOSFET opposite to the PWM MOSFET stays off (passive FW)

11.3.3.5 Measurements of the switching times

The effective switching times in PWM operation:

- of the PWM MOSFET if **EN_GEN_CHECK** = 0
- of the active MOSFET if **EN_GEN_CHECK** = 1

are reported in the registers:

EFF_TDON_OFF1, EFF_TDON_OFF2, EFF_TDON_OFF3.

If the end of the rise time for a given MOSFET is not detected before $t_{HBxBLANK}$ Active elapses, then the corresponding status register reports an effective rise time equal to zero.

If the end of the fall time for a given MOSFET is not detected before t_{HBxCCP} Active active elapses, then the corresponding status register reports an effective fall time equal to zero.

The device cannot measure the switching times t_{DON} , t_{DOFF} , t_{RISE} and t_{FALL} at very high and very low duty cycles: $t_{ON} < t_{HBxCCP}$ FW and $t_{OFF} < t_{HBxCCP}$ active. In this case, the corresponding registers report effective t_{DON} , t_{DOFF} , t_{RISE} and t_{FALL} equal to zero.

Gate Drivers

11.3.4 PWM operation with 6 PWM inputs

Each high-side MOSFET and each low-side MOSFET is controlled by one PWM input. if PWM_NB is set to 1 (see [CSA](#)) and HBx_PWM_EN are set to 1 (see [HBMODE](#)). Refer to [Table 23](#).

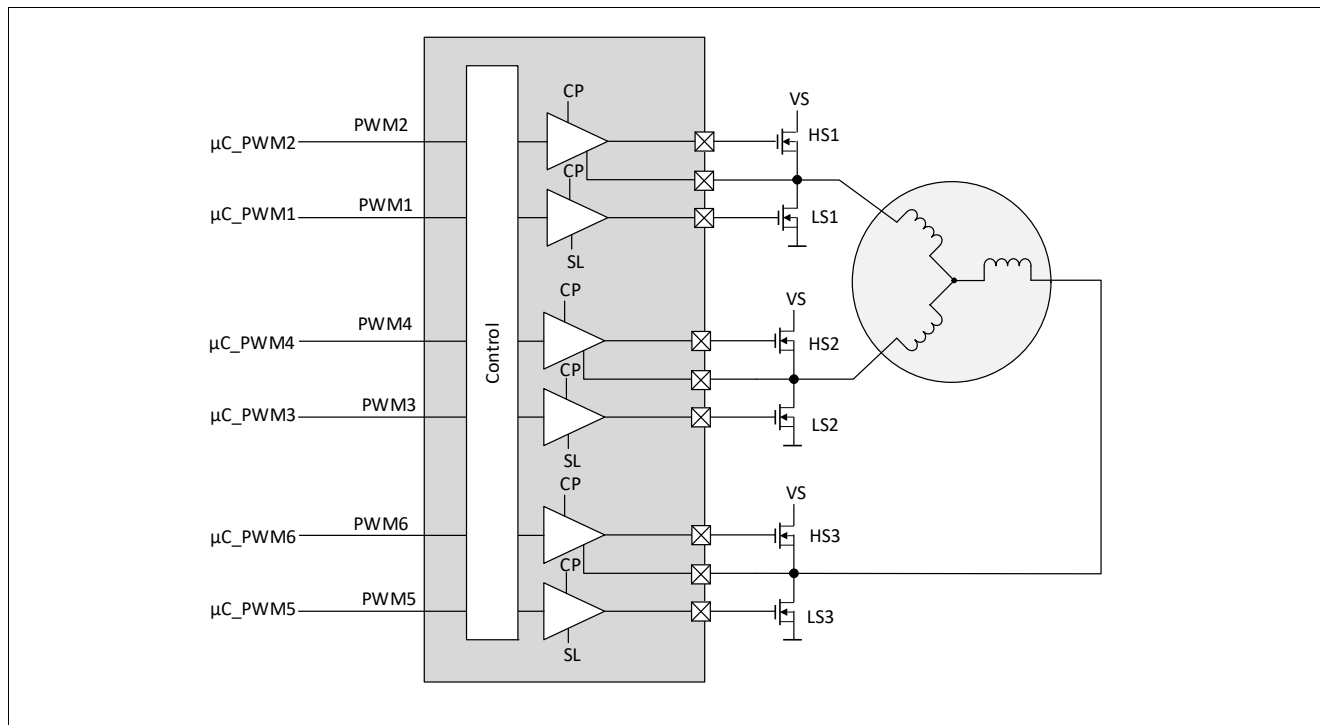

Figure 52 Half-bridge PWM control with six PWM inputs, PWM_NB = 1

Table 23 Half-bridge PWM settings with 6 PWM inputs (PWM_NB = 1)FW and Active MOSFET

PWM_NB	HBx_PWM_EN ¹⁾	HBxMODE ¹⁾	Half-bridge x settings ¹⁾
1	Don't care	00 _B	LSx and HSx MOSFETs are kept OFF by the passive discharge (default)
1	1	01 _B	HBx is controlled by its PWM inputs <ul style="list-style-type: none"> If EN_GEN_CHECK = 0: LSx is always considered as the active MOSFET If EN_GEN_CHECK = 1: The active and the FW MOSFETs are detected according to Chapter 11.3.1, independently from HBxMODE
1	1	10 _B	HBx is controlled by its PWM inputs <ul style="list-style-type: none"> If EN_GEN_CHECK = 0: HSx is always considered as the active MOSFET If EN_GEN_CHECK = 1: The active and the FW MOSFETs are detected according to Chapter 11.3.1 independently from HBxMODE
1	Don't care	11 _B	LSx and HSx MOSFETs are actively kept OFF

1) x = 1 to 3

Gate Drivers

Table 24 PWM Control of HS1 and LS1, PWM_NB = 1, HB1_PWM_EN = 1

HB1MODE[1:0]	PWM1/CRC	PWM2	HS1	LS1
01	Low	Low	OFF	OFF
01	Low	High	ON	OFF
01	High	Low	OFF	ON
01	High	High	OFF	OFF
10	Low	Low	OFF	OFF
10	Low	High	OFF	ON
10	High	Low	ON	OFF
10	High	High	OFF	OFF

Table 25 PWM Control of HS2 and LS2, PWM_NB = 1, HB2_PWM_EN = 1

HB2MODE[1:0]	PWM3	PWM4	HS2	LS2
01	Low	Low	OFF	OFF
01	Low	High	ON	OFF
01	High	Low	OFF	ON
01	High	High	OFF	OFF
10	Low	Low	OFF	OFF
10	Low	High	OFF	ON
10	High	Low	ON	OFF
10	High	High	OFF	OFF

Table 26 PWM Control of HS3 and LS3, PWM_NB = 1, HB3_PWM_EN = 1

HB3MODE[1:0]	PWM5	PWM6	HS3	LS3
01	Low	Low	OFF	OFF
01	Low	High	ON	OFF
01	High	Low	OFF	ON
01	High	High	OFF	OFF
10	Low	Low	OFF	OFF
10	Low	High	OFF	ON
10	High	Low	ON	OFF
10	High	High	OFF	OFF

Figure 53 shows the PWM control of HBx in PWM (HBx_PWM_EN = 1): Turn-off of the FW MOSFET (low-side MOSFET in this case) followed by the activation of the active MOSFET (high-side MOSFET in this case)¹⁾ with PWM_NB = 1, AGC[1:0]=01_B or 10_B, **POCHGDIS** = 0 (post-charge enabled).

This control scheme is applicable for the following cases:

1) If the synchronized HS PWM rising edge occurs after tHBxCCP FW and before the end of tOFF timeout FW, then the LS MOSFET is discharged with IHARDOFF and the HS is turned on, when the HS PWM rising edge is detected

Gate Drivers

1. **EN_GEN_CHECK** = 0 (detection of FW/Active MOSFET disabled); HBxMODE[1:0] = 10_B (HS MOSFET is considered as active MOSFET by default).
2. **EN_GEN_CHECK** = 1 (detection of active / FW MOSFET enabled); HS MOSFET detected as active MOSFET; HBxMODE[1:0] = 01_B or 10_B.

Note: If the synchronized HS PWM rising edge occurs before the end of tHBxCCP active, then the device prevents an activation of the HS MOSFET until tHBxCCP FW elapses. In other words, the HS PWM rising edge is ignored until the end of tHBxCCP FW.

Gate Drivers

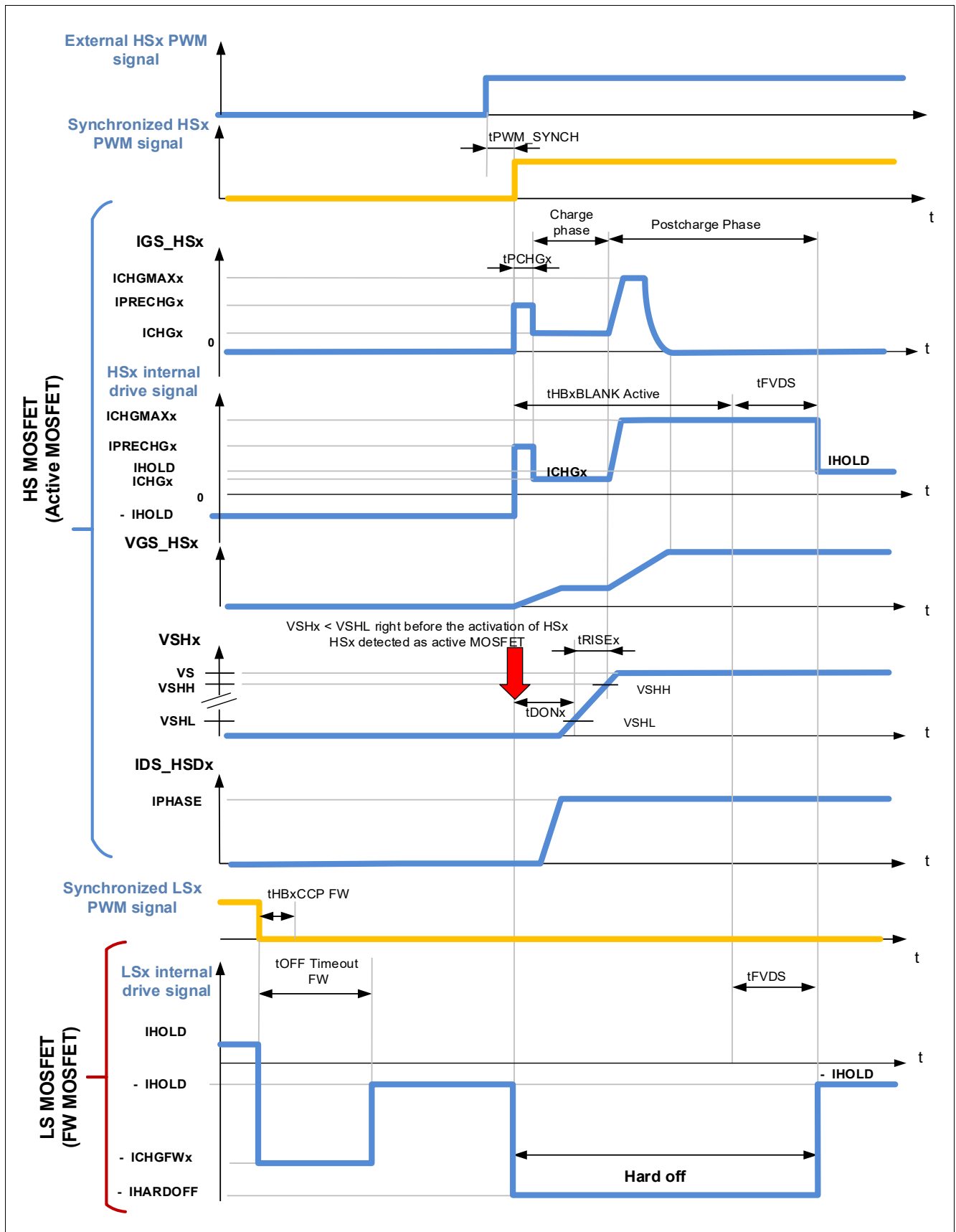

Figure 53 Turn-on of an active MOSFET in PWM mode with active gate control, HS as active MOSFET, LS as FW MOSFET. Two PWM inputs per half-bridge, active gate control enabled. PWM_EN = 1

Gate Drivers

Figure 54 shows the PWM control of HBx in PWM (HBx_PWM_EN = 1): Turn-off of the active MOSFET (high-side MOSFET in this case) followed by the activation of the FW MOSFET low-side MOSFET in this case) with PWM_NB = 1, AGC[1:0] = 01_B or 10_B, **POCHDIS** = 0 (post-charge enabled).

This control scheme is applicable for the following cases:

1. **EN_GEN_CHECK** = 0 (detection of FW/Active MOSFET disabled); HBxMODE[1:0] = 10_B (HS MOSFET is considered as active MOSFET by default).
2. **EN_GEN_CHECK** = 1 (detection of active / FW MOSFET enabled); HS MOSFET detected as active MOSFET; HBxMODE[1:0] = 01_B or 10_B.

Note: If the synchronized LS PWM rising edge occurs before the end of tHBxCCP active, then the device prevents an activation of the LS MOSFET until tHBxCCP active elapses. In other words, the LS PWM rising edge is ignored until the end of tHBxCCP active.

Gate Drivers

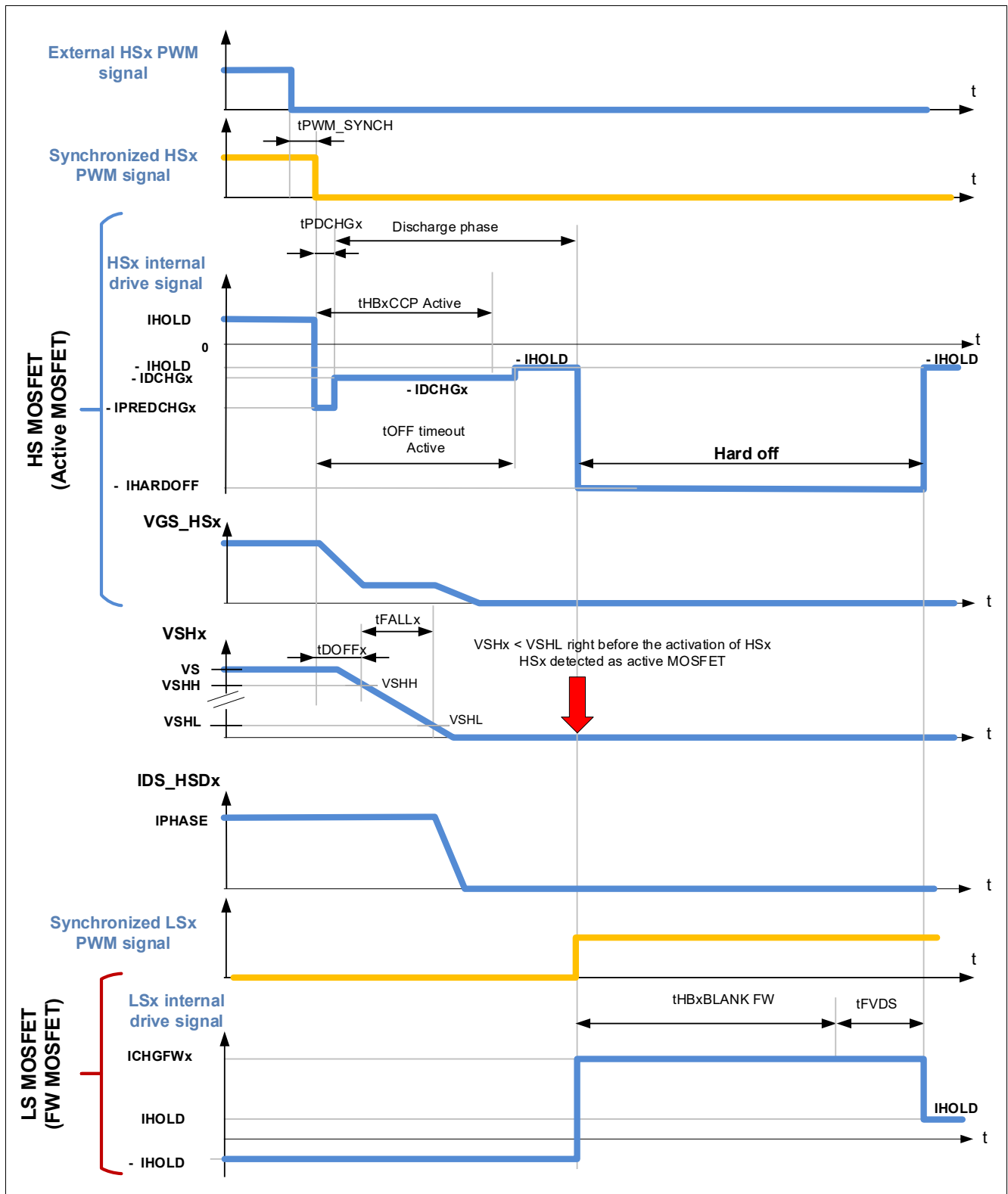

Figure 54 Turn-off of an active MOSFET in PWM mode with active gate control, HS as active MOSFET, LS as FW MOSFET. two PWM inputs per half-bridge, active gate control enabled. PWM_NB=1.

11.3.5 Status bits for regulation of turn-on and turn-off delay times

The control bits TDREGx (**TDREG**) indicate if t_{DONx} and t_{DOFFx} of the half-bridge x, using the adaptive control scheme ($AGC = 10_B$ or 11_B), are in regulation.

Gate Drivers

The half-bridge x is considered in regulation if one of the following conditions is met:

- Condition 1: The effective turn-on and turn-off delays are equal to the configured delays for at least eight cumulative PWM cycle (HBx tDON counter ≥ 8 and HBx tDOFF counter ≥ 8). For each PWM cycle
 - if $t_{DONxEFF}^{1)} = T_{DONx}^{2)}$, $x = 1..3$, HBx tDON counter is incremented
 - if $t_{DONxEFF}^{1)} \neq T_{DONx}^{2)}$, $x = 1..3$, HBx tDON counter is decremented
 - if $t_{DOFFxEFF}^{1)} = T_{DOFFx}^{3)}$, $x = 1..3$, HBx tDOFF counter is incremented
 - if $t_{DOFFxEFF}^{1)} \neq T_{DOFFx}^{3)}$, $x = 1..3$, HBx tDOFF counter is decremented
- Condition 2: The error between the effective delays (($t_{DONxEFF} - T_{DONx}$) and ($t_{DOFFxEFF} - T_{DOFFx}$)) changes its sign three times consecutively

1) Refer to [EFF_TDON_OFF1](#), [EFF_TDON_OFF2](#), [EFF_TDON_OFF3](#)

2) Refer to [TDON_HB_CTRL](#)

3) Refer to [TDOFF_HB_CTRL](#)

Gate Drivers

11.3.6 Gate driver current

Each gate driver is able to source and sink currents from 0.5 mA to 150 mA, with 64 steps.

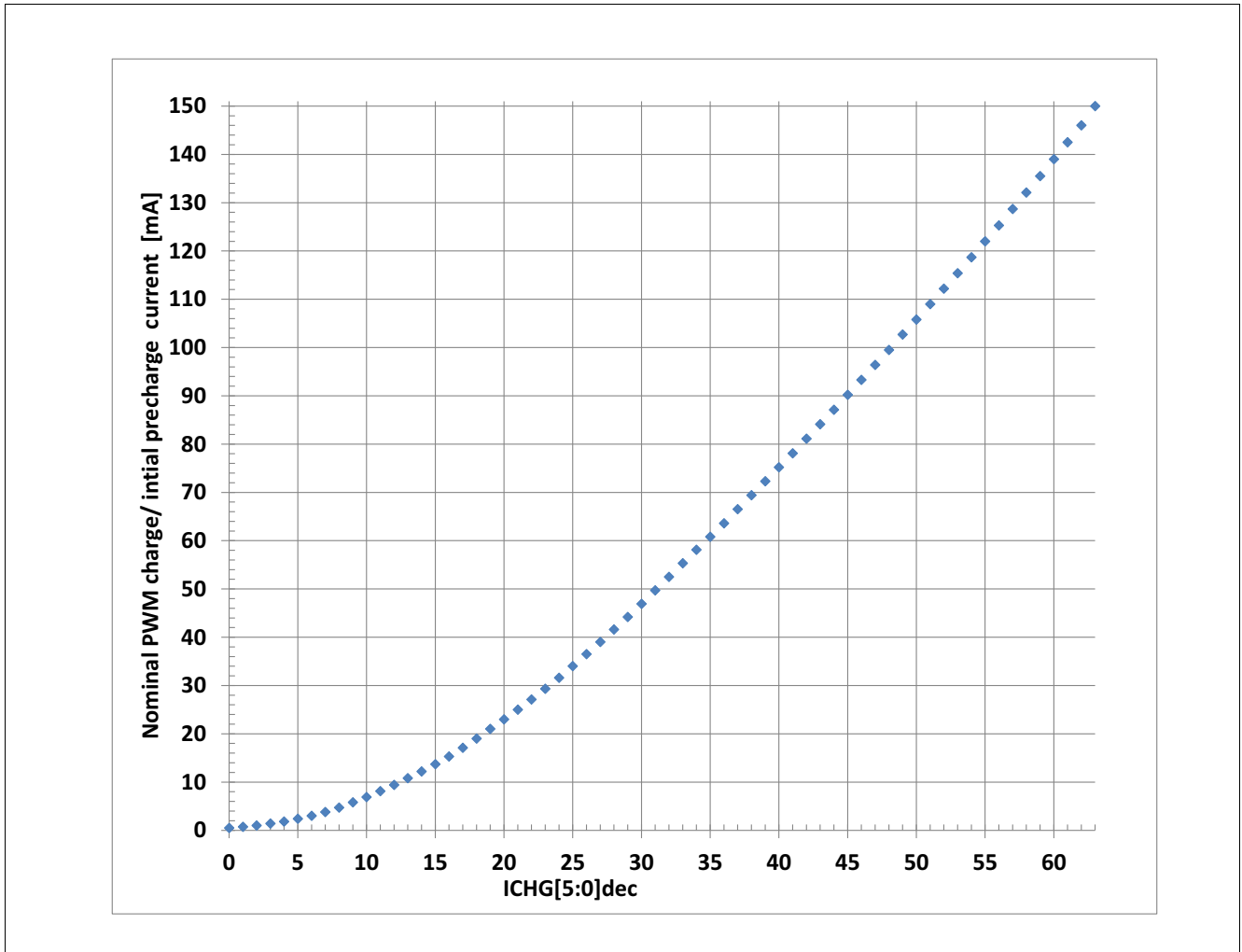

Figure 55 Configurable discharge currents in PWM operation

Gate Drivers

Table 27 Charge currents and initial precharge currents

ICHGx[5:0], PCHGINITx[5:0]	Parameter name	Nom. current [mA]	Max. deviation to nominal values [%]
00000 _B	I_{CHG0}	0.5	+/- 60%
000001 _B	I_{CHG1}	0.7	+/- 60 %
000010 _B	I_{CHG2}	1.0	+/- 60 %
000011 _B	I_{CHG3}	1.4	+/- 60 %
000100 _B	I_{CHG4}	1.8	+/- 60 %
000101 _B	I_{CHG5}	2.4	+/- 60 %
000110 _B	I_{CHG6}	3.0	+/- 60 %
000111 _B	I_{CHG7}	3.8	+/- 60 %
001000 _B	I_{CHG8}	4.7	+/- 55%
001001 _B	I_{CHG9}	5.8	+/- 55%
001010 _B	I_{CHG10}	6.9	+/- 55%
001011 _B	I_{CHG11}	8.1	+/- 55%
001100 _B	I_{CHG12}	9.4	+/- 55%
001101 _B	I_{CHG13}	10.8	+/- 55%
001110 _B	I_{CHG14}	12.2	+/- 40%
001111 _B	I_{CHG15}	13.7	+/- 40%
010000 _B	I_{CHG16}	15.3	+/- 40 %
010001 _B	I_{CHG17}	17.1	+/- 40 %
010010 _B	I_{CHG18}	19	+/- 40%
010011 _B	I_{CHG19}	21	+/- 40 %
010100 _B	I_{CHG20}	23	+/- 40%
010101 _B	I_{CHG21}	25	+/- 40 %
010110 _B	I_{CHG22}	27.1	+/- 40 %
010111 _B	I_{CHG23}	29.3	+/- 40 %
011000 _B	I_{CHG24}	31.6	+/- 40 %
011001 _B	I_{CHG25}	34	+/- 40 %
011010 _B	I_{CHG26}	36.5	+/- 40 %
011011 _B	I_{CHG27}	39	+/- 40 %
011100 _B	I_{CHG28}	41.6	+/- 40 %
011101 _B	I_{CHG29}	44.2	+/- 30 %
011110 _B	I_{CHG30}	46.9	+/- 30 %
011111 _B	I_{CHG31}	49.7	+/- 30 %
100000 _B	I_{CHG32}	52.5	+/- 30 %
100001 _B	I_{CHG33}	55.3	+/- 30 %
100010 _B	I_{CHG34}	58.1	+/- 30 %
100011 _B	I_{CHG35}	60.8	+/- 30 %

Gate Drivers

Table 27 Charge currents and initial precharge currents (cont'd)

ICHGx[5:0], PCHGINITx[5:0]	Parameter name	Nom. current [mA]	Max. deviation to nominal values [%]
100100 _B	I_{CHG36}	63.6	+/- 30 %
100101 _B	I_{CHG37}	66.5	+/- 30 %
100110 _B	I_{CHG38}	69.4	+/- 30 %
100111 _B	I_{CHG39}	72.3	+/- 30 %
101000 _B	I_{CHG40}	75.2	+/- 30 %
101001 _B	I_{CHG41}	78.1	+/- 30 %
101010 _B	I_{CHG42}	81.1	+/- 30 %
101011 _B	I_{CHG43}	84.1	+/- 30 %
101100 _B	I_{CHG44}	87.1	+/- 30 %
101101 _B	I_{CHG45}	90.2	+/- 30 %
101110 _B	I_{CHG46}	93.3	+/- 30 %
101111 _B	I_{CHG47}	96.4	+/- 30 %
110000 _B	I_{CHG48}	99.5	+/- 30 %
110001 _B	I_{CHG49}	102.7	+/- 30 %
110010 _B	I_{CHG50}	105.8	+/- 30 %
110011 _B	I_{CHG51}	109	+/- 30 %
110100 _B	I_{CHG52}	112.2	+/- 30 %
110101 _B	I_{CHG53}	115.4	+/- 30 %
110110 _B	I_{CHG54}	118.7	+/- 30 %
110111 _B	I_{CHG55}	122	+/- 30 %
111000 _B	I_{CHG56}	125.3	+/- 30 %
111001 _B	I_{CHG57}	128.7	+/- 30 %
111010 _B	I_{CHG58}	132.1	+/- 30 %
111011 _B	I_{CHG59}	135.5	+/- 30 %
111100 _B	I_{CHG60}	139	+/- 30 %
111101 _B	I_{CHG61}	142.5	+/- 30 %
111110 _B	I_{CHG62}	146	+/- 30 %
111111 _B	I_{CHG63}	150	+/- 30 %

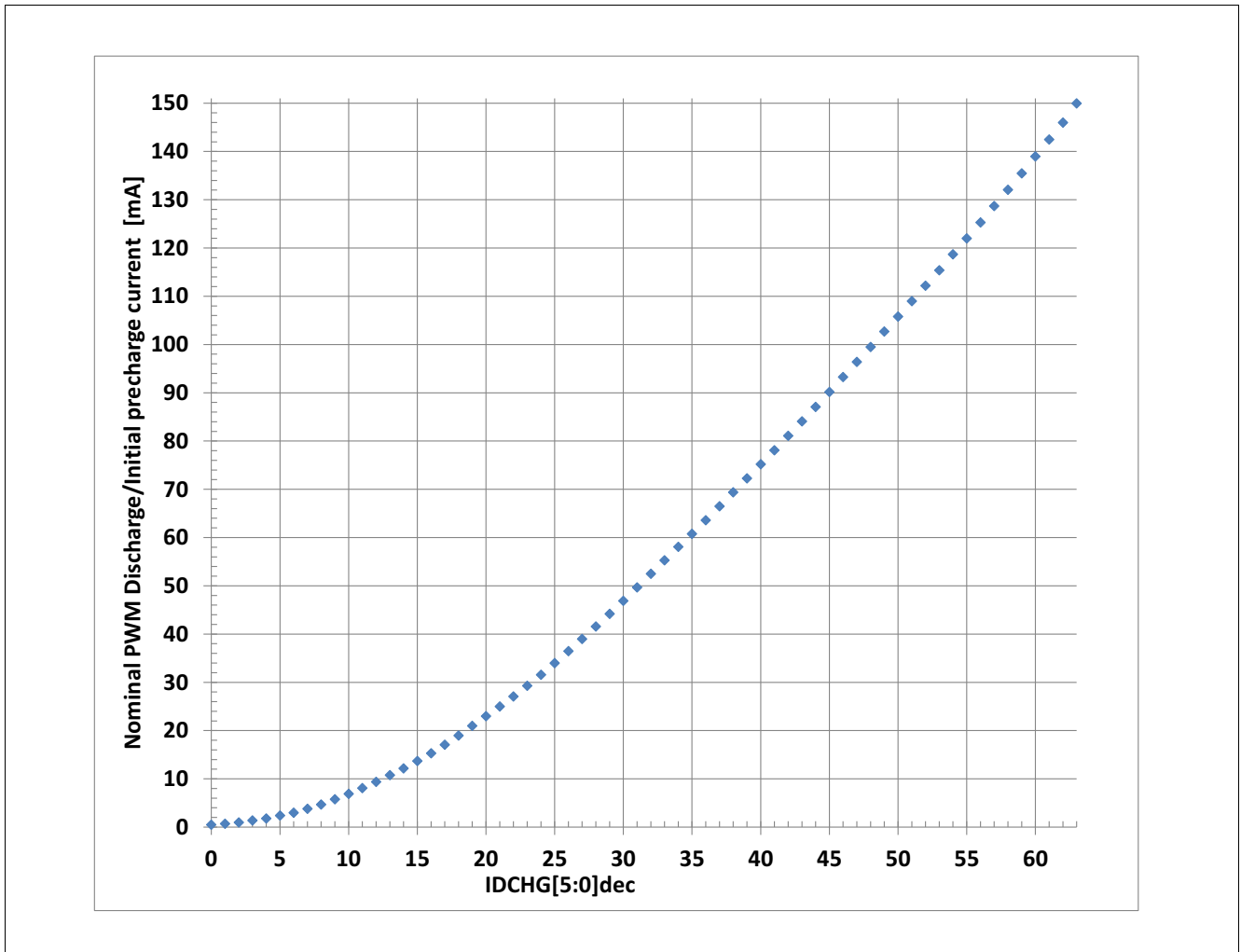

Figure 56 Configurable discharge currents in PWM operation

Gate Drivers

Table 28 Discharge currents and initial pre-discharge currents

IDCHG[5:0], PDCHGINITx[5:0]	Parameter name	Nom. current [mA]	Max. deviation to nominal values [%]
00000 _B	I_{DCHG0}	0.5	+/- 60%
000001 _B	I_{DCHG1}	0.7	+/- 60 %
000010 _B	I_{DCHG2}	1.0	+/- 60 %
000011 _B	I_{DCHG3}	1.4	+/- 60 %
000100 _B	I_{DCHG4}	1.8	+/- 60 %
000101 _B	I_{DCHG5}	2.4	+/- 60 %
000110 _B	I_{DCHG6}	3.0	+/- 60 %
000111 _B	I_{DCHG7}	3.8	+/- 60 %
001000 _B	I_{DCHG8}	4.7	+/- 60 %
001001 _B	I_{DCHG9}	5.8	+/- 60 %
001010 _B	I_{DCHG10}	6.9	+/- 60 %
001011 _B	I_{DCHG11}	8.1	+/- 60 %
001100 _B	I_{DCHG12}	9.4	+/- 60 %
001101 _B	I_{DCHG13}	10.7	+/- 60 %
001110 _B	I_{DCHG14}	12.1	+/- 40%
001111 _B	I_{DCHG15}	13.5	+/- 40%
010000 _B	I_{DCHG16}	15.1	+/- 40 %
010001 _B	I_{DCHG17}	16.8	+/- 40 %
010010 _B	I_{DCHG18}	18.6	+/- 40%
010011 _B	I_{DCHG19}	20.5	+/- 40 %
010100 _B	I_{DCHG20}	22.5	+/- 40%
010101 _B	I_{DCHG21}	24.5	+/- 40 %
010110 _B	I_{DCHG22}	26.5	+/- 40 %
010111 _B	I_{DCHG23}	28.7	+/- 40 %
011000 _B	I_{DCHG24}	30.9	+/- 40 %
011001 _B	I_{DCHG25}	33.2	+/- 40 %
011010 _B	I_{DCHG26}	35.7	+/- 40 %
011011 _B	I_{DCHG27}	38.2	+/- 40 %
011100 _B	I_{DCHG28}	40.8	+/- 40 %
011101 _B	I_{DCHG29}	43.4	+/- 30 %
011110 _B	I_{DCHG30}	46.1	+/- 30 %
011111 _B	I_{DCHG31}	48.8	+/- 30 %
100000 _B	I_{DCHG32}	51.5	+/- 30 %
100001 _B	I_{DCHG33}	54.2	+/- 30 %
100010 _B	I_{DCHG34}	56.9	+/- 30 %
100011 _B	I_{DCHG35}	59.6	+/- 30 %

Gate Drivers

Table 28 Discharge currents and initial pre-discharge currents (cont'd)

IDCHG[5:0], PDCHGINITx[5:0]	Parameter name	Nom. current [mA]	Max. deviation to nominal values [%]
100100 _B	I_{DCHG36}	62.4	+/- 30 %
100101 _B	I_{DCHG37}	65.2	+/- 30 %
100110 _B	I_{DCHG38}	68	+/- 30 %
100111 _B	I_{DCHG39}	70.8	+/- 30 %
101000 _B	I_{DCHG40}	73.7	+/- 30 %
101001 _B	I_{DCHG41}	76.6	+/- 30 %
101010 _B	I_{DCHG42}	79.5	+/- 30 %
101011 _B	I_{DCHG43}	82.5	+/- 30 %
101100 _B	I_{DCHG44}	85.5	+/- 30 %
101101 _B	I_{DCHG45}	88.5	+/- 30 %
101110 _B	I_{DCHG46}	91.5	+/- 30 %
101111 _B	I_{DCHG47}	94.6	+/- 30 %
110000 _B	I_{DCHG48}	97.7	+/- 30 %
110001 _B	I_{DCHG49}	100.9	+/- 30 %
110010 _B	I_{DCHG50}	104.2	+/- 30 %
110011 _B	I_{DCHG51}	107.5	+/- 30 %
110100 _B	I_{DCHG52}	110.8	+/- 30 %
110101 _B	I_{DCHG53}	114.2	+/- 30 %
110110 _B	I_{DCHG54}	117.6	+/- 30 %
110111 _B	I_{DCHG55}	121	+/- 30 %
111000 _B	I_{DCHG56}	124.5	+/- 30 %
111001 _B	I_{DCHG57}	128	+/- 30 %
111010 _B	I_{DCHG58}	131.5	+/- 30 %
111011 _B	I_{DCHG59}	135.1	+/- 30 %
111100 _B	I_{DCHG60}	138.7	+/- 30 %
111101 _B	I_{DCHG61}	142.3	+/- 30 %
111110 _B	I_{DCHG62}	145.8	+/- 30 %
111111 _B	I_{DCHG63}	150	+/- 30 %

11.4 Passive discharge

Resistors (R_{GGND}) between the gate of GHx and GND, and between GLx and GND, ensure that the external MOSFETs are turned off in the following conditions:

- V_{CC1} undervoltage
- HBxMODE = 00_B in Normal Mode
- **CPEN** = 0 in Normal Mode
- CSA Overcurrent detection with **OCEN** = 1 in normal mode

Gate Drivers

- VS overvoltage or VSINT overvoltage
- Charge pump undervoltage and charge pump blank time ($t_{\text{CPUVBLANK}}$)
- Charge pump overtemperature (**CP_OT**)
- VDS overvoltage after active discharge in Normal Mode
- In Init Mode, Stop Mode, Fail Safe Mode, Restart Mode and Sleep Mode (exceptions for low-sides in parking braking and VS / VSINT overvoltage braking, refer to **Chapter 11.6** and **Chapter 12.10.3**)

11.5 Slam mode

The slam mode is applicable in Normal Mode.

If the SLAM bit is set in **BRAKE** register:

1. If HBxMODE = 01b or 10b, then the corresponding MOSFETs are actively turned off with their static discharge current during their respective tHBxCCP Active.
2. Then charge pump is deactivated independently from **CPEN**
3. Then PWM1/CRC input pin is mapped to LS1, LS2, LS3, independently from PWM_NB, HBxMODE and HBx_PWM_EN
 - a) If PWM1/CRC is High, then the low-side MOSFETs are turned on within $t_{\text{ON_BRAKE}}$.
 - b) If PWM1/CRC is Low, then the low-side MOSFETs are turned off within $t_{\text{OFF_BRAKE}}$.

There is also the possibility to disable selectively the LSx in SLAM mode.

11.6 Parking braking mode

If **PARK_BRK_EN** bit is set, while the device goes in Sleep Mode or in Stop Mode:

1. If HBxMODE = 01b or 10b, then the corresponding MOSFETs are actively turned off with their static discharge current during their respective tHBxCCP Active.
2. Then charge pump is deactivated independently from CPEN bit.
3. Then the passive discharge (R_{GGND}) of the low-sides is deactivated, the passive discharge of the high-sides are activated
4. If PWM1/CRC is High, then the low-side MOSFETs are turned on within $t_{\text{ON_BRAKE}}$.

Refer to **Chapter 12.10.2** for the protection of the of low-side MOSFETs against short circuits when the parking braking mode is activated.

11.7 Charge pump

A dual-stage charge pump supplies the gate drivers for the high-side and low-side MOSFETs. It requires three external capacitors connected between CPC1N and CPC1P, CPC2N and CPC2P, VS and CP.

The buffer capacitor between VS and CP must have a capacitance equal or higher than 470 nF.

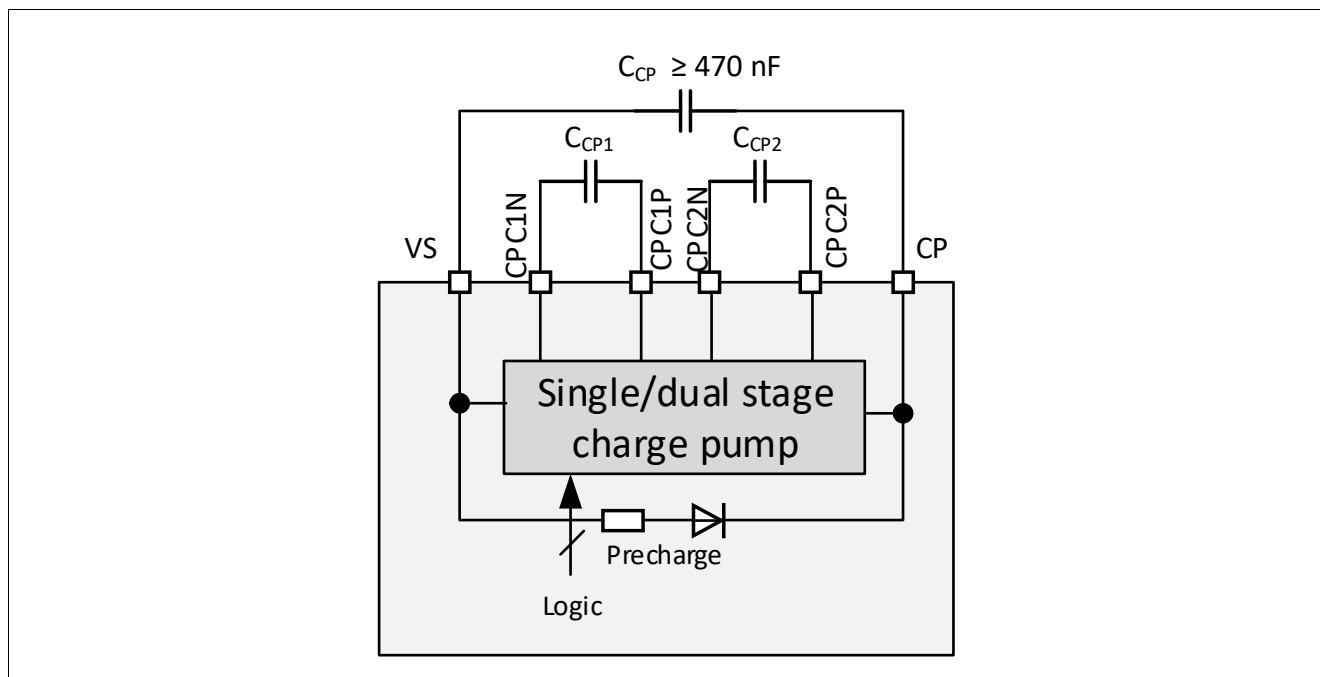

Figure 57 Charge pump - Block diagram

Logic or normal level MOSFETs

The regulation of the charge pump outputs voltage can be configured depending on the type of MOSFET.

FET_LVL = 0: Logic level MOSFETs are selected:

- $V_{CP} - V_S = V_{CP3}$ (11 V typ. at $V_S > 8$ V).
- The high-side gate-source voltage $G_{Hx} - S_{Hx}$ is V_{GH4} ($V_S > 8$ V).
- The low-side gate-source voltage $G_{Lx} - S_{Lx}$ is V_{GH3} ($V_S > 8$ V).

FET_LVL = 1: Normal level MOSFETs are selected:

- $V_{CP} - V_S = V_{CP1}$ (15 V typ. at $V_S > 8$ V).
- The high-side and low-side gate-source voltage $G_{Hx} - S_{Hx}$ or $G_{Lx} - S_{Lx}$ is V_{GH1} ($V_S > 8$ V).

$CPSTGA = 0$ (default, see **GENCTRL**), the device operates with the dual-stage charge pump.

If $CPSTGA = 1$, the device switches to single-stage or dual-stage charge pump automatically:

- If $V_S > V_{CPSO_{DS}}$: the TLE9564QX switches from a dual-stage to a single-stage charge pump.
- If $V_S < V_{CPSO_{SD}}$: the TLE9564QX switches from single-stage to dual-stage charge pump.

The operation with the single-stage charge pump reduces the current consumption from the VS pin.

11.8 Frequency modulation

A modulation of the charge pump frequency can be activated to reduce the peak emission.

The modulation frequency is set by the control bit FMODE in **GENCTRL**:

- FMODE = 0: No modulation.
- FMODE = 1: Modulation frequency = 15.6 kHz (default).

Gate Drivers

11.9 Electrical characteristics gate driver

The electrical characteristics related to the gate driver are valid for $V_{CP} > V_S + 8.5 V$

Table 29 Electrical characteristics: gate drivers

$V_{SINT} = 5.5 V$ to $28 V$, $T_j = -40^\circ C$ to $+150^\circ C$,

$V_{CP} > V_S + 8.5 V$, $V_S = 6$ to $19V$, all voltages with respect to ground, positive current flowing into pin except for I_{GLx} and I_{GHx} (unless otherwise specified).

Parameter	Symbol	Values			Unit	Note or Test Condition	Number
		Min.	Typ.	Max.			
Comparators							
SHx High Threshold	V_{SHH}	$V_S - 2.6$	–	$V_S - 1.9$	V		P_12.11.1
SHx Low Threshold	V_{SHL}	1.9	–	2.6	V	Referred to GND	P_12.11.2
SHx comparator delay	t_{SHx}	–	12	30	ns	1)	P_12.11.3
MOSFET Driver Output							
High Level Output Voltage GHx vs. SHx and GLx vs. SL	V_{GH1}	10	11.5	12.5	V	2) $V_S \geq 8 V$, $C_{Load} = 10 nF$, $I_{CP} = -12 mA$, FET_LVL = 1	P_12.11.4
High Level Output Voltage GHx vs. SHx and GLx vs. SL	V_{GH2}	7	–	12.5	V	$V_S = 6 V$, $C_{Load} = 10 nF$, $I_{CP} = -6 mA$, FET_LVL = 1	P_12.11.5
High Level Output Voltage GLx vs. SL	V_{GH3}	10	–	12.5	V	3) $V_S \geq 6 V$, $C_{Load} = 10 nF$, FET_LVL = 0	P_12.11.6
High Level Output Voltage GHx vs. SHx	V_{GH4}	8.5	10	12.5	V	2) $V_S \geq 8 V$, $C_{Load} = 10 nF$, $I_{CP} = -12 mA$, FET_LVL = 0	P_12.11.7
High Level Output Voltage GHx vs. SHx	V_{GH5}	7	–	12.5	V	$V_S = 6 V$, $C_{LOAD} = 10 nF$, $I_{CP} = -6 mA$, FET_LVL = 0	P_12.11.8
Charge current	I_{CHG0}	-60%	0.5	+60%	mA	$I_{CHG} = 0_D$ 1) $C_{Load} = 2.2 nF$ $V_S \geq 8V, V_{GS} \leq V_{GS(ON)}$ 4)	P_12.11.70
Charge current	I_{CHG8}	-55%	4.7	+55%	mA	$I_{CHG} = 8_D$ 1) $C_{Load} = 2.2 nF$ $V_S \geq 8V, V_{GS} \leq V_{GS(ON)}$ 4)	P_12.11.71
Charge current	I_{CHG16}	-40%	15.3	+40%	mA	$I_{CHG} = 16_D$ 1) $C_{Load} = 2.2 nF$ $V_S \geq 8V, V_{GS} \leq V_{GS(ON)}$ 4)	P_12.11.72
Charge current	I_{CHG32}	-30%	52.5	+30%	mA	$I_{CHG} = 32_D$ 1) $C_{Load} = 10 nF$ $V_S \geq 8V, V_{GS} \leq V_{GS(ON)}$ 4)	P_12.11.73

Gate Drivers

Table 29 Electrical characteristics: gate drivers (cont'd)

$V_{SINT} = 5.5\text{ V to }28\text{ V}$, $T_j = -40^\circ\text{C to }+150^\circ\text{C}$,

$V_{CP} > V_S + 8.5\text{ V}$, $V_S = 6\text{ to }19\text{ V}$, all voltages with respect to ground, positive current flowing into pin except for I_{GLX} and I_{GHX} (unless otherwise specified).

Parameter	Symbol	Values			Unit	Note or Test Condition	Number
		Min.	Typ.	Max.			
Charge current	I_{CHG48}	-30%	99.5	+30%	mA	$ICHG = 48\text{ D}^{1)}$ $C_{Load} = 10\text{ nF}$ $V_S \geq 8\text{ V}$, $V_{GS} \leq V_{GS(ON)}^{4)}$	P_12.11.74
Charge current	I_{CHG63}	-30%	150	+30%	mA	$ICHG = 63\text{ D}^{1)}$ $C_{Load} = 22\text{ nF}$ $V_S \geq 8\text{ V}$, $V_{GS} \leq V_{GS(ON)}^{4)}$	P_12.11.75
Discharge current	I_{DCH0}	-60%	-0.5	+60%	mA	$IDCHG = 0\text{ D}^{1)}$ $C_{Load} = 2.2\text{ nF}$ $V_S \geq 8\text{ V}$, $V_{GS} \geq V_{GS(OFF1)}$	P_12.11.76
Discharge current	I_{DCH8}	-55%	-4.7	55%	mA	$IDCHG = 8\text{ D}^{1)}$ $C_{Load} = 2.2\text{ nF}$ $V_S \geq 8\text{ V}$, $V_{GS} \geq V_{GS(OFF1)}$	P_12.11.77
Discharge current	I_{DCHG16}	-40%	-15.1	+40%	mA	$IDCHG = 16\text{ D}^{1)}$ $C_{Load} = 2.2\text{ nF}$ $V_S \geq 8\text{ V}$, $V_{GS} \geq V_{GS(OFF1)}$	P_12.11.78
Discharge current	I_{DCHG32}	-30%	-51.5	+30%	mA	$IDCHG = 32\text{ D}^{1)}$ $C_{Load} = 10\text{ nF}$ $V_S \geq 8\text{ V}$, $V_{GS} \geq V_{GS(OFF2)}$	P_12.11.79
Discharge current	I_{DCHG48}	-30%	-97.7	+30%	mA	$IDCHG = 48\text{ D}^{1)}$ $C_{Load} = 10\text{ nF}$ $V_S \geq 8\text{ V}$, $V_{GS} \geq V_{GS(OFF2)}$	P_12.11.80
Discharge current	I_{DCHG63}	-30%	-150	+30%	mA	$IDCHG = 63\text{ D}^{1)}$ $C_{Load} = 22\text{ nF}$ $V_S \geq 8\text{ V}$, $V_{GS} \geq V_{GS(OFF2)}$	P_12.11.81
Charge current temperature drift	$I_{CHG0,TDrift}$	-37%	-12%	15%		$ICHG = 0\text{ D}^{1)5)}$	P_12.11.119
Charge current temperature drift	$I_{CHG8,TDrift}$	-17%	1%	20%		$ICHG = 8\text{ D}^{1)5)}$	P_12.11.120
Charge current temperature drift	$I_{CHG16,TDrift}$	-12%	3%	18%		$ICHG = 16\text{ D}^{1)5)}$	P_12.11.121
Charge current temperature drift	$I_{CHG32,TDrift}$	-11%	-1%	9%		$ICHG = 32\text{ D}^{1)5)}$	P_12.11.122
Charge current temperature drift	$I_{CHG48,TDrift}$	-7.5%	0.5%	8%		$ICHG = 48\text{ D}^{1)5)}$	P_12.11.123
Charge current temperature drift	$I_{CHG63,TDrift}$	-5.5%	1.5%	8.5%		$IDCHG = 63\text{ D}^{1)5)}$	P_12.11.124
Discharge current temperature drift	$I_{DCHG0,TDrift}$	-29%	-4.5%	20%		$IDCHG = 0\text{ D}^{1)5)}$	P_12.11.125

Gate Drivers

Table 29 Electrical characteristics: gate drivers (cont'd)

$V_{SINT} = 5.5\text{ V to }28\text{ V}$, $T_j = -40^\circ\text{C to }+150^\circ\text{C}$,

$V_{CP} > V_S + 8.5\text{ V}$, $V_S = 6\text{ to }19\text{ V}$, all voltages with respect to ground, positive current flowing into pin except for I_{GLx} and I_{GHx} (unless otherwise specified).

Parameter	Symbol	Values			Unit	Note or Test Condition	Number
		Min.	Typ.	Max.			
Discharge current temperature drift	$I_{DCHG8,TDrift}$	-8%	8.5%	26%		IDCHG = $8_D^{1)5)}$	P_12.11.126
Discharge current temperature drift	$I_{DCHG16,TDrift}$	-4%	9.5%	23%		IDCHG = $16_D^{1)5)}$	P_12.11.127
Discharge current temperature drift	$I_{DCHG32,TDrift}$	-4%	4.5%	13%		IDCHG = $32_D^{1)5)}$	P_12.11.128
Discharge current temperature drift	$I_{DCHG48,TDrift}$	-4%	3.5%	10%		IDCHG = $48_D^{1)5)}$	P_12.11.129
Discharge current temperature drift	$I_{DCHG63,TDrift}$	-3.5%	3.5%	9.5%		IDCHG = $63_D^{1)5)}$	P_12.11.130
Charge current V_S drift	$I_{CHG0,VsDrift}$	3%	4.5%	6%		ICHG = $0_D^{1)6)}$	P_12.11.131
Charge current V_S drift	$I_{CHG8,VsDrift}$	4.5%	6%	7.5%		ICHG = $8_D^{1)6)}$	P_12.11.132
Charge current V_S drift	$I_{CHG16,VsDrift}$	4%	5.8%	7.5%		ICHG = $16_D^{1)6)}$	P_12.11.133
Charge current V_S drift	$I_{CHG32,VsDrift}$	2%	3.8%	5.8%		ICHG = $32_D^{1)6)}$	P_12.11.134
Charge current V_S drift	$I_{CHG48,VsDrift}$	-0.5%	2%	4.5%		ICHG = $48_D^{1)6)}$	P_12.11.135
Charge current V_S drift	$I_{CHG63,VsDrift}$	-2.3%	0.3%	2.8%		ICHG = $63_D^{1)6)}$	P_12.11.136
Discharge current V_S drift	$I_{DCHG0,VsDrift}$	-3%	-1.5%	0%		IDCHG = $0_D^{1)6)}$	P_12.11.137
Discharge current V_S drift	$I_{DCHG8,VsDrift}$	-3%	-0.5%	2%		IDCHG = $8_D^{1)6)}$	P_12.11.138
Discharge current V_S drift	$I_{DCHG16,VsDrift}$	-3.3%	-0.3%	2.3%		IDCHG = $16_D^{1)6)}$	P_12.11.139
Discharge current V_S drift	$I_{DCHG32,VsDrift}$	-2%	0%	2%		IDCHG = $32_D^{1)6)}$	P_12.11.140
Discharge current V_S drift	$I_{DCHG48,VsDrift}$	-1.5%	0%	1.5%		IDCHG = $48_D^{1)6)}$	P_12.11.141
Discharge current V_S drift	$I_{DCHG63,VsDrift}$	-1.5%	0.2%	1.5%		IDCHG = $63_D^{1)6)}$	P_12.11.142
Passive discharge resistance between GHx/GLx and GND	R_{GGND}	10	20	30	k Ω	¹⁾	P_12.11.22
Resistor between SHx and GND	R_{SHGND}	10	20	30	k Ω	¹⁾⁷⁾	P_12.11.23
Low RDSON mode	R_{ONCCP}	-	22	35	Ω	¹⁾ $V_S = 13.5\text{ V}$ $V_{CP} = V_S + 14\text{ V}$ $I_{CHG} = I_{DCHG} = 63_D$	P_12.11.24

Gate Drivers Dynamic Parameters

Gate Drivers

Table 29 Electrical characteristics: gate drivers (cont'd)

$V_{SINT} = 5.5\text{ V to }28\text{ V}$, $T_j = -40^\circ\text{C to }+150^\circ\text{C}$,

$V_{CP} > V_S + 8.5\text{ V}$, $V_S = 6\text{ to }19\text{ V}$, all voltages with respect to ground, positive current flowing into pin except for I_{GLX} and I_{GHX} (unless otherwise specified).

Parameter	Symbol	Values			Unit	Note or Test Condition	Number
		Min.	Typ.	Max.			
Gate Driver turn-on delay Time	t_{DGDRV_ON1}	–	–	400	ns	⁸⁾ From PWM ⁹⁾ rising edge to 20% of I_{CHGx} , $x = 0\text{ to }63$, $C_{Load} = 10\text{ nF}$, BDFREQ = 0	P_12.11.25
Gate Driver turn-on delay Time	t_{DGDRV_ON2}	–	–	300	ns	⁸⁾ From PWM ⁹⁾ rising edge to 20% of I_{CHGx} , $x = 0\text{ to }63$, $C_{Load} = 10\text{ nF}$, BDFREQ = 1	P_12.11.93
Gate Driver current turn-on rise time	$t_{GDRV_RISE(ON)}$	–	30	50	ns	⁸⁾ From 20% of I_{CHGx} to I_{CHGx} , $x = 0\text{ to }63$, $C_{Load} = 10\text{ nF}$	P_12.11.26
Gate Driver turn-off delay Time	t_{DGDRV_OFF1}	–	–	400	ns	⁸⁾ From PWM ⁹⁾ rising edge to 20% of I_{DCHGx} , $x = 0\text{ to }63$, $C_{Load} = 10\text{ nF}$, BDFREQ = 0	P_12.11.27
Gate Driver turn-off delay Time	t_{DGDRV_OFF2}	–	–	300	ns	⁸⁾ From PWM ⁹⁾ rising edge to 20% of I_{DCHGx} , $x = 0\text{ to }63$, $C_{Load} = 10\text{ nF}$, BDFREQ = 1	P_12.11.94
Gate Driver current turn-off rise time	$t_{GDRV_RISE(OFF)}$	–	30	50	ns	⁸⁾ From 20% of I_{DCHGx} to I_{DCHGx} , $x = 0\text{ to }63$, $C_{Load} = 10\text{ nF}$	P_12.11.28
External MOSFET gate-to-source voltage - ON	$V_{GS(ON)1}$	7	–	–	V	¹⁾ $V_S \geq 8\text{ V}$, FET_LVL =1	P_12.11.29
External MOSFET gate-to-source voltage - ON	$V_{GS(ON)1}$	7	–	–	V	¹⁾ $V_S \geq 8\text{ V}$, FET_LVL =1	P_12.11.102
External MOSFET gate-to-source voltage - ON	$V_{GS(ON)2}$	5.5	–	–	V	¹⁾ $V_S \geq 8\text{ V}$, FET_LVL =0	P_12.11.103
External MOSFET gate-to-source voltage - OFF	$V_{GS(OFF)1}$	–	–	1.5	V	¹⁾ $IDCHGx \leq 24_D (\leq 41\text{ mA typ.})$	P_12.11.30

Gate Drivers

Table 29 Electrical characteristics: gate drivers (cont'd)

$V_{SINT} = 5.5\text{ V to }28\text{ V}$, $T_j = -40^\circ\text{C to }+150^\circ\text{C}$,

$V_{CP} > V_S + 8.5\text{ V}$, $V_S = 6\text{ to }19\text{ V}$, all voltages with respect to ground, positive current flowing into pin except for I_{GLX} and I_{GHX} (unless otherwise specified).

Parameter	Symbol	Values			Unit	Note or Test Condition	Number
		Min.	Typ.	Max.			
External MOSFET gate-to-source voltage - OFF	$V_{GS(OFF)2}$	-	-	5	V	¹⁾ IDCHGx > 28 _D (> 41 mA typ.)	P_12.11.101
PWM synchronization delay	t_{PWM_SYNCH0}	80	-	200	ns	¹⁾ BDFREQ = 0	P_12.11.33
PWM synchronization delay	t_{PWM_SYNCH1}	40	-	100	ns	¹⁾ BDFREQ = 1	P_12.11.82
Bridge driver frequency	$t_{BDFREQ0}$	16.8	18.75	20.7	MHz	¹⁾ BDFREQ = 0	P_12.11.83
Bridge driver frequency	$t_{BDFREQ1}$	33.7	37.5	42.3	MHz	¹⁾ BDFREQ = 1	P_12.11.84
Pre-charge time	$t_{PCHG000}$	80	107	140	ns	¹⁾ TPCHG = 000, BDFREQ = 0 or 1	P_12.11.34
Pre-charge time	$t_{PCHG001}$	130	160	190	ns	¹⁾ TPCHG = 001, BDFREQ = 0 or 1	P_12.11.35
Pre-charge time	$t_{PCHG010}$	170	214	260	ns	¹⁾ TPCHG = 010, BDFREQ = 0 or 1	P_12.11.36
Pre-charge time	$t_{PCHG011}$	210	267	330	ns	¹⁾ TPCHG = 011, BDFREQ = 0 or 1	P_12.11.37
Pre-charge time	$t_{PCHG100}$	250	320	390	ns	¹⁾ TPCHG = 100, BDFREQ = 0 or 1	P_12.11.85
Pre-charge time	$t_{PCHG101}$	420	533	630	ns	¹⁾ TPCHG = 101, BDFREQ = 0 or 1	P_12.11.86
Pre-charge time	$t_{PCHG110}$	600	747	900	ns	¹⁾ TPCHG = 110, BDFREQ = 0 or 1	P_12.11.87
Pre-charge time	$t_{PCHG111}$	840	1067	1260	ns	¹⁾ TPCHG = 111, BDFREQ = 0 or 1	P_12.11.88
Pre-discharge time	$t_{PDCHG000}$	80	107	140	ns	¹⁾ TPDCHG = 000, BDFREQ = 0 or 1	P_12.11.38
Pre-discharge time	$t_{PDCHG001}$	130	160	190	ns	¹⁾ TPDCHG = 001, BDFREQ = 0 or 1	P_12.11.39
Pre-discharge time	$t_{PDCHG010}$	170	214	260	ns	¹⁾ TPDCHG = 010, BDFREQ = 0 or 1	P_12.11.40
Pre-discharge time	$t_{PDCHG011}$	210	267	330	ns	¹⁾ TPDCHG = 011, BDFREQ = 0 or 1	P_12.11.41
Pre-discharge time	$t_{PDCHG100}$	250	320	390	ns	¹⁾ TPDCHG = 100, BDFREQ = 0 or 1	P_12.11.89
Pre-discharge time	$t_{PDCHG101}$	420	533	630	ns	¹⁾ TPDCHG = 101, BDFREQ = 0 or 1	P_12.11.90
Pre-discharge time	$t_{PDCHG110}$	600	747	900	ns	¹⁾ TPDCHG = 110, BDFREQ = 0 or 1	P_12.11.91

Gate Drivers

Table 29 Electrical characteristics: gate drivers (cont'd)

$V_{SINT} = 5.5\text{ V to }28\text{ V}$, $T_j = -40^\circ\text{C to }+150^\circ\text{C}$,
 $V_{CP} > V_S + 8.5\text{ V}$, $V_S = 6\text{ to }19\text{V}$, all voltages with respect to ground, positive current flowing into pin except for I_{GLX} and I_{GHX} (unless otherwise specified).

Parameter	Symbol	Values			Unit	Note or Test Condition	Number
		Min.	Typ.	Max.			
Pre-discharge time	$t_{PDCHG111}$	840	1067	1260	ns	¹⁾ TPDCHG = 111, BDFREQ = 0 or 1	P_12.11.92
Discharge timeout	$t_{OFF_TIMEOUT}$	3.2	4	4.8	μs	¹⁾ PWM_NB=1 _B	P_12.11.9

Low-side gate driver, CP off - Slam mode, parking braking and VS overvoltage braking

LS turn-on time, CP off	t_{ON_BRAKE}	-	4.5	9	μs	$C_{LOAD} = 10\text{ nF}$ $V_{GLX-VSL} = 5\text{ V}$, $V_S > 8\text{ V}$ or $V_{SINT} > 8\text{ V}$	P_12.11.42
LS turn-off time, CP off	t_{OFF_BRAKE}	-	0.7	2	μs	$C_{LOAD} = 10\text{ nF}$ $V_{GLX-VSL} = 1.5\text{ V}$, $V_S > 8\text{ V}$ or $V_{SINT} > 8\text{ V}$	P_12.11.43
High output voltage GLX - SL	V_{GLX_BRAKE}	5	-	10	V	$V_S > 8\text{ V}$ or $V_{SINT} > 8\text{ V}$	P_12.11.48

Charge pump

Charge Pump Frequency	f_{CP}	-	250	-	kHz	¹⁾	P_12.11.49
Output Voltage VCP vs. VS	V_{CPmin1}	8.5	-	-	V	$V_S = 6\text{ V}$, $I_{CP} = -6\text{ mA}$, FET_LVL = 1	P_12.11.50
Output Voltage VCP vs. VS	V_{CPmin2}	7.5	-	-	V	$V_S = 6\text{ V}$, $I_{CP} = -6\text{ mA}$, FET_LVL = 0	P_12.11.51
Regulated CP output voltage, VCP vs. VS	V_{CP1}	12	15	17	V	$8\text{ V} < V_S < 23\text{ V}$ $I_{CP} = -12\text{ mA}^{11)}$, CPSTGA = 0, FET_LVL = 1	P_12.11.52
Regulated CP output voltage, VCP vs. VS	V_{CP2}	12	15	17	V	$18\text{ V} < V_S < 23\text{ V}$ $I_{CP} = -12\text{ mA}^{11)}$, CPSTGA = 1, FET_LVL = 1	P_12.11.53
Regulated CP output voltage, VCP vs. VS	V_{CP3}	7.5	11	13	V	$8\text{ V} < V_S < 23\text{ V}$ $I_{CP} = -12\text{ mA}^{11)}$, CPSTGA = 0, FET_LVL = 0	P_12.11.54
Regulated CP output voltage, VCP vs. VS	V_{CP4}	7.5	11	13	V	$13\text{ V} < V_S < 23\text{ V}$ $I_{CP} = -12\text{ mA}^{11)}$, CPSTGA = 0, FET_LVL = 0	P_12.11.55
Turn-on time	t_{ON_VCP1}	5	-	60	μs	¹⁾¹⁰⁾¹¹⁾ $18\text{ V} < V_S < 23\text{ V}$ (25%), $I_{CP} = 0$, CPSTGA = 1, FET_LVL = 1	P_12.11.56

Gate Drivers

Table 29 Electrical characteristics: gate drivers (cont'd)

$V_{SINT} = 5.5\text{ V to }28\text{ V}$, $T_j = -40^\circ\text{C to }+150^\circ\text{C}$,

$V_{CP} > V_S + 8.5\text{ V}$, $V_S = 6\text{ to }19\text{ V}$, all voltages with respect to ground, positive current flowing into pin except for I_{GLX} and I_{GHX} (unless otherwise specified).

Parameter	Symbol	Values			Unit	Note or Test Condition	Number
		Min.	Typ.	Max.			
Rise time	t_{RISE_VCP1}	5	30	60	μs	¹⁾¹⁰⁾¹¹⁾ $18\text{ V} < V_S < 23\text{ V}$ (25%-75%) $I_{CP} = 0$, CPSTGA = 1, FET_LVL = 1	P_12.11.57
Turn-on time	t_{ON_VCP2}	20	60	120	μs	¹⁾¹⁰⁾¹¹⁾ $13\text{ V} < V_S < 23\text{ V}$ (25%), $I_{CP} = 0$, CPSTGA = 1, FET_LVL = 0	P_12.11.58
Rise time	t_{RISE_VCP2}	5	30	60	μs	¹⁾¹⁰⁾¹¹⁾ $13\text{ V} < V_S < 23\text{ V}$ (25%-75%) $I_{CP} = 0$, CPSTGA = 1, FET_LVL = 0	P_12.11.59
Automatic switch over dual to single stage charge pump	V_{CPSO_DS}	16	17	18	V	CPSTGA = 1, FET_LVL = 1, VS rising	P_12.11.60
Automatic switch over dual to single stage charge pump	V_{CPSO_DS}	11.5	12.25	13	V	CPSTGA = 1, FET_LVL = 0, VS rising	P_12.11.61
Automatic switch over single to dual stage charge pump	V_{CPSO_SD}	15.5	16.5	17.5	V	CPSTGA = 1, FET_LVL = 1, VS falling	P_12.11.62
Automatic switch over single to dual stage charge pump	V_{CPSO_SD}	11	11.75	12.5	V	CPSTGA = 1, FET_LVL = 0, VS falling	P_12.11.64
Charge pump switch over hysteresis	V_{CPSO_HY}	-	0.5	-	V	¹⁾ CPSTGA = 1 $V_{CPSO_DS} - V_{CPSO_SD}$	P_12.11.65
Charge pump minimum output current	I_{CPOC1}	-	-	-12	mA	¹¹⁾ $8\text{ V} < V_S < 28\text{ V}$ CPSTGA = 0 FET_LVL = 1	P_12.11.68
Charge pump minimum output current	I_{CPOC2}	-	-	-12	mA	¹¹⁾ $8\text{ V} < V_S < 28\text{ V}$ CPSTGA = 0 FET_LVL = 0	P_12.11.69

Gate Drivers

Table 29 Electrical characteristics: gate drivers (cont'd)

$V_{SINT} = 5.5\text{ V to }28\text{ V}$, $T_j = -40^\circ\text{C to }+150^\circ\text{C}$,

$V_{CP} > V_S + 8.5\text{ V}$, $V_S = 6\text{ to }19\text{ V}$, all voltages with respect to ground, positive current flowing into pin except for I_{GLx} and I_{GHx} (unless otherwise specified).

Parameter	Symbol	Values			Unit	Note or Test Condition	Number
		Min.	Typ.	Max.			
Digital PWMx Inputs							
High Level Input Voltage Threshold	V_{PVMH}	–	–	$0.7 \times V_{CC1}$	V	–	P_12.11.95
Low Level Input Voltage Threshold	$V_{PVM L}$	$0.3 \times V_{CC1}$	–	–	V	–	P_12.11.96
PWMx Input Hysteresis	$V_{PVM,hys}$	–	$0.12 \times V_{CC1}$	–	V	1)	P_12.11.97
PWMx Pull-down Resistance	R_{PD_PWM}	20	40	80	k Ω	–	P_12.11.98
CRC Select; Pin PWM1/CRC							
Config Pull-up Resistance	R_{CFG}		100		k Ω	12)	P_12.11.99
Config Select Filter Time	t_{CFG_F}	5	10	14	μs	1)	P_12.11.105

1) Not subject to production test, specified by design.

2) Independent from **CPSTGA**.

3) $ICP = -12\text{ mA}$ for $V_S \geq 8\text{ V}$, $ICP = 6\text{ mA}$ for $V_S = 6\text{ V}$.

4) $V_{GS(ON)} = V_{GS(ON)1}$ if **FET_LVL** = 1, $V_{GS(ON)} = V_{GS(ON)2}$ if **FET_LVL** = 0.

5) T_j reference = 25°C

6) Valid for $V_S = 8\text{ to }19\text{ V}$, V_S reference = 13.5 V

7) This resistance is the resistance between GHx and GND connected through a diode to SHx. As a consequence, the voltage at SHx can rise up to 0.6 V typ. before it is discharged through the resistor.

8) Not subject to production test, specified by design.

9) External PWM signal.

10) Parameter dependent on the capacitance C_{CP} .

11) $C_{CPC1} = C_{CPC2} = 220\text{ nF}$, $C_{CP} = 470\text{ nF}$. Other C_{CP} values higher than 470 nF can be used. Note that this capacitor influences the charge pump rise and turn-on times, and the charge, V_{CP} ripple voltage when charging the gate of a MOSFET.

12) Config Pull-up will be only active during startup-phase for checking external pull-down. After checking, the typ. $40\text{ k}\Omega$ Pull-down resistance will be present.

12 Supervision Functions

12.1 Reset Function

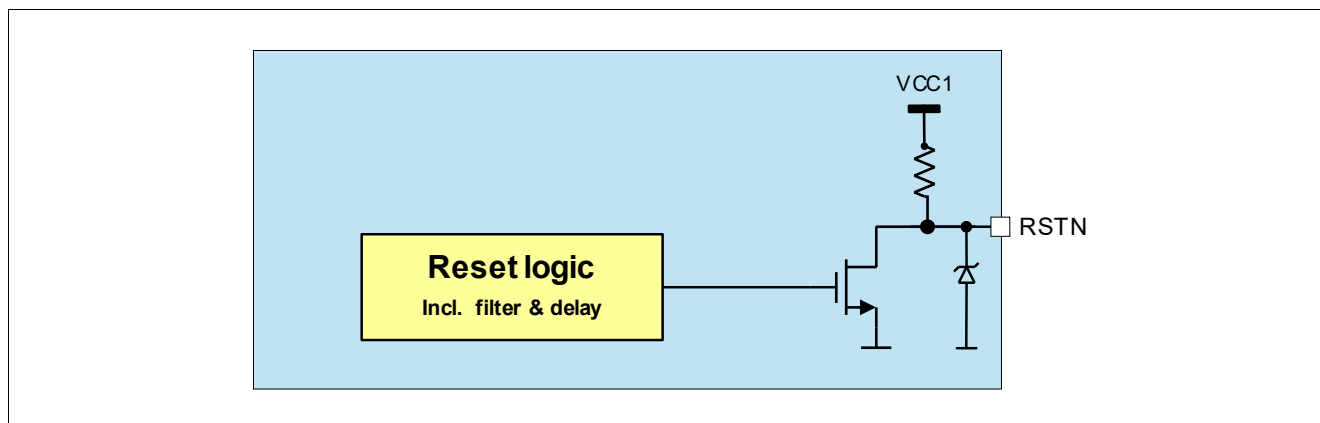

Figure 58 Reset Block Diagram

12.1.1 Reset Output Description

The reset output pin RSTN provides a reset information to the microcontroller, for example, in the event that the output voltage has fallen below the undervoltage threshold V_{RTX} . In case of a reset event, the reset output RSTN is pulled to low after the filter time t_{RF} and stays low as long as the reset event is present plus a reset delay time t_{RD1} or t_{RD2} depending on the value in **RSTN_DEL**. When connecting the device to battery voltage, the reset signal remains low initially. When the output voltage VCC1 has reached the reset default threshold $V_{RT1,r}$ the reset output RSTN is released to high after the reset delay time t_{RD1} . A reset can also occur due to a watchdog trigger failure. The reset threshold can be adjusted via SPI, the default reset threshold is $V_{RT1,f}$. The RSTN pin has an integrated pull-up resistor. In case reset is triggered, it will be pulled low for $VCC1 \geq 1V$ and for $VSINT \geq V_{POR,f}$ (see also [Chapter 12.3](#)).

The timings for the RSTN triggering regarding VCC1 undervoltage and watchdog trigger is shown in [Figure 59](#).

Supervision Functions

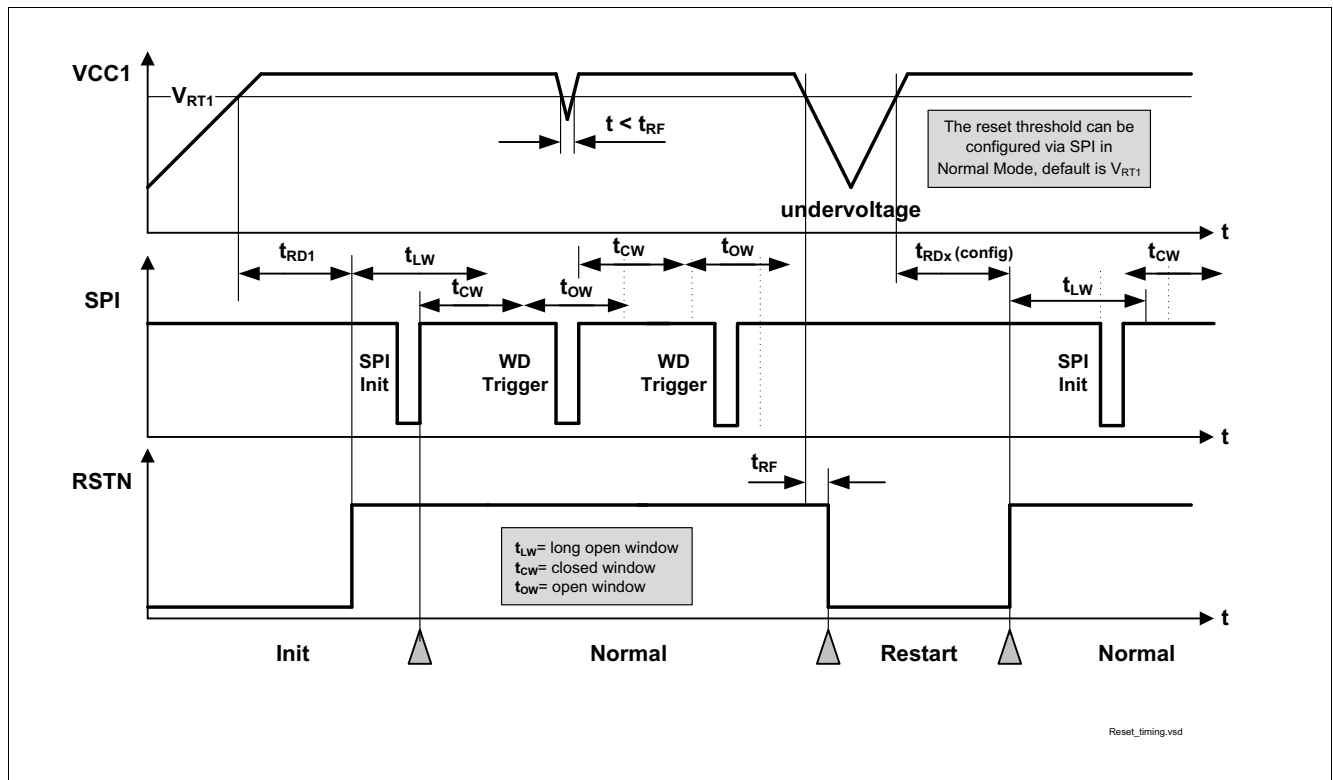

Figure 59 Reset Timing Diagram

12.1.2 Soft Reset Description

In Normal Mode and Stop Mode, it is also possible to trigger a device internal reset via a SPI command in order to bring the device into a defined state in case of failures. In this case the microcontroller must send a SPI command and set the **MODE** bits to '11' in the **M_S_CTRL** register. As soon as this command becomes valid, the device is set back to Init Mode and all SPI registers are set to their default values (see SPI [Chapter 13.5.1](#) and [Chapter 13.6.1](#)).

Two different soft reset configurations are possible via the SPI bit **SOFT_RESET_RO**:

- **SOFT_RESET_RO** = '0': The reset output (RSTN) is triggered when the soft reset is executed (default setting) The configured reset delay time **t_{RD1}** or **t_{RD2}** is applied depending on the value in **RSTN_DEL**.
- **SOFT_RESET_RO** = '1': The reset output (RSTN) is not triggered when the soft reset is executed.

Note: The device must be in Normal Mode or Stop Mode when sending this command. Otherwise, the command will be ignored.

Note: Allow CRC configuration after software-reset - or better check once again via SPI after software reset.

Supervision Functions

12.2 Watchdog Function

The watchdog is used to monitor the software execution of the microcontroller and to trigger a reset or move the device to Fail Safe Mode, if the microcontroller stops serving the watchdog due to a lock up in the software.

Two different types of watchdog functions are implemented and can be selected via the bit **WD_CFG**:

- Time-Out Watchdog (default value)
- Window Watchdog

The respective watchdog functions can be selected and programmed in Normal Mode. The configuration stays unchanged in Stop Mode.

Please refer to **Table 30** to match the device modes with the respective watchdog modes.

Table 30 Watchdog Functionality by modes

Mode	Watchdog Mode	Remarks
Init Mode	Starts with Long Open Window	Watchdog starts with Long Open Window after RSTN is released.
Normal Mode	WD Programmable	Window Watchdog, Time-Out watchdog or switched off for Stop Mode.
Stop Mode	Watchdog is fixed or off	
Sleep Mode	Off	Device will start with Long Open Window when entering Normal Mode.
Restart Mode	Off	Device will start with Long Open Window when entering Normal Mode.

The watchdog timing is programmed via SPI command in the register **WD_CTRL**. As soon as the watchdog is programmed, the timer starts with the new setting and the watchdog must be served. The watchdog is triggered by sending a valid SPI-write command to the watchdog configuration register. The watchdog trigger command is executed when the SPI command is interpreted.

When coming from Init Mode, Restart Mode or in certain cases from Stop Mode, the watchdog timer is always started with a long open window. The long open window (t_{LW}) allows the microcontroller to run its initialization sequences and then to trigger the watchdog via SPI.

The watchdog timer period can be selected via SPI (**WD_TIMER**).The timer setting is valid for both watchdog types.

The following watchdog timer periods are available:

- WD Setting 1: 10 ms
- WD Setting 2: 20 ms
- WD Setting 3: 50 ms
- WD Setting 4: 100 ms
- WD Setting 5: 200 ms
- WD Setting 6: 500 ms
- WD Setting 7: 1 s
- WD Setting 8: 10 s

In case of a reset, Restart Mode or Fail-Safe Mode is entered according to the configuration and the SPI bits **WD_FAIL** are set. Once the RSTN goes high again the watchdog immediately starts with a long open window the device enters automatically Normal Mode.

The Watchdog behaviour in Software Development Mode is described in **Chapter 5.4.7**.

Supervision Functions

In case a watchdog-trigger was missed in Software Development Mode, the watchdog will start with the long-open-window once again.

The **WD_FAIL** bits will be set after a watchdog trigger failure.

The **WD_FAIL** bits are cleared automatically when following conditions apply:

- After a successful watchdog trigger.
- When the watchdog is off: in Stop Mode after successfully disabling it, in Sleep Mode, or in Fail-Safe Mode (except for a watchdog failure).

12.2.1 Time-Out Watchdog

The time-out watchdog is an easier and less secure watchdog than a window watchdog as the watchdog trigger can be done at any time within the configured watchdog timer period.

A correct watchdog service immediately results in starting a new watchdog timer period. Taking the tolerances of the internal oscillator into account leads to the safe trigger area as defined in **Figure 60**.

If the time-out watchdog period elapses, a watchdog reset is created by setting the reset output RSTN low and the device switches to Restart Mode or Fail-Safe Mode.

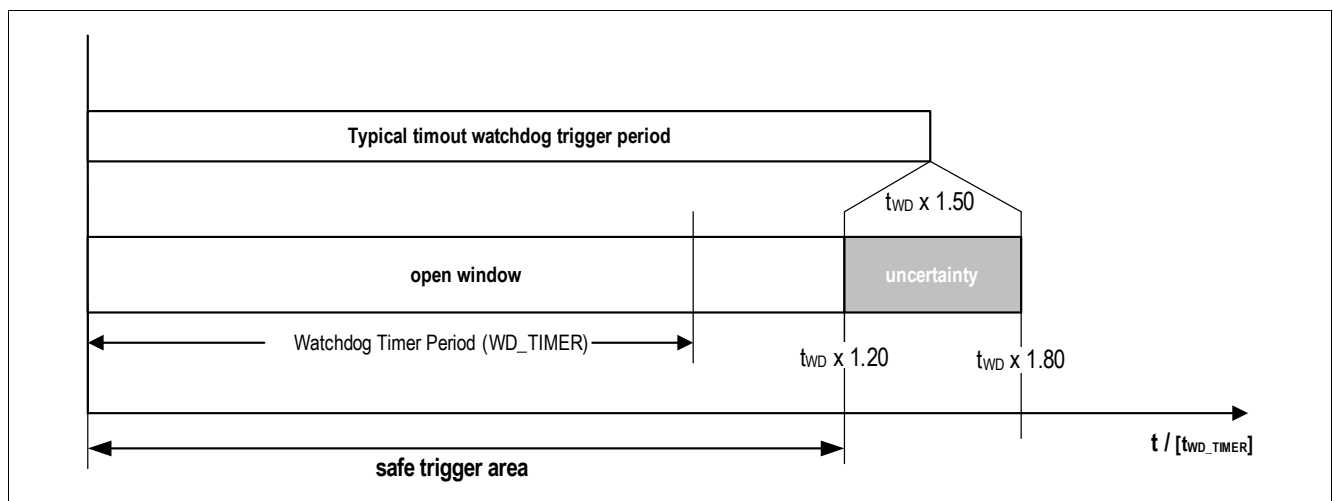

Figure 60 Time-out Watchdog Definitions

Supervision Functions

12.2.2 Window Watchdog

Compared to the time-out watchdog the characteristic of the window watchdog is that the watchdog timer period is divided between a closed and an open window. The watchdog must be triggered within the open window.

A correct watchdog trigger results in starting the window watchdog period by a closed window followed by an open window.

The watchdog timer period is at the same time the typical trigger time and defines the middle of the open window. Taking the oscillator tolerances into account leads to a safe trigger area of:

$$t_{WD} \times 0.72 < \text{safe trigger area} < t_{WD} \times 1.20.$$

The typical closed window is defined to a width of 60% of the selected window watchdog timer period. Taking the tolerances of the internal oscillator into account leads to the timings as defined in **Figure 61**.

A correct watchdog service immediately results in starting the next closed window.

If the trigger signal meet the closed window or if the watchdog timer period elapses, then a watchdog reset is triggered (RSTN low) and the device switches to Restart Mode or Fail-Safe Mode.

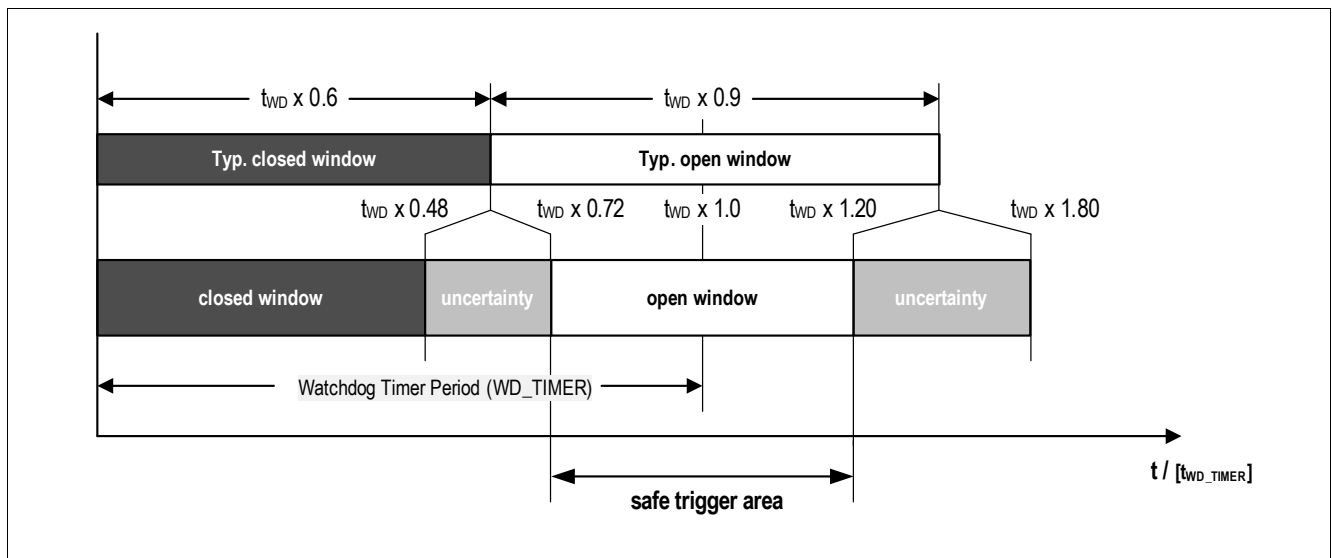

Figure 61 Window Watchdog Definitions

12.2.3 Watchdog Setting Check Sum

A check sum bit is part of the SPI command to trigger the watchdog and to set the watchdog setting.

The sum of the 16 data bits in the register **WD_CTRL** needs to have even parity (see **Equation (12.1)**). This is realized by either setting the bit **CHECKSUM** to 0 or 1. If the check sum is wrong, then the SPI command is ignored, i.e. the watchdog is not triggered or the settings are not changed and the bit **SPI_FAIL** is set.

The written value of the reserved bits of the **WD_CTRL** register is considered (even if read as '0' in the SPI output) for checksum calculation, i.e. if a 1 is written on the reserved bit position, then a 1 will be used in the checksum calculation.

(12.1)

$$\text{Bit}(\text{CHECKSUM}) = \text{Bit}22 \oplus \dots \oplus \text{Bit}8$$

12.2.4 Watchdog during Stop Mode

The watchdog can be disabled for Stop Mode in Normal Mode. For safety reasons, there is a special sequence to be followed in order to disable the watchdog as described in [Figure 62](#). Two different SPI bits ([WD_STM_EN_0](#), [WD_STM_EN_1](#)) in the registers [HW_CTRL](#) and [WD_CTRL](#) need to be set.

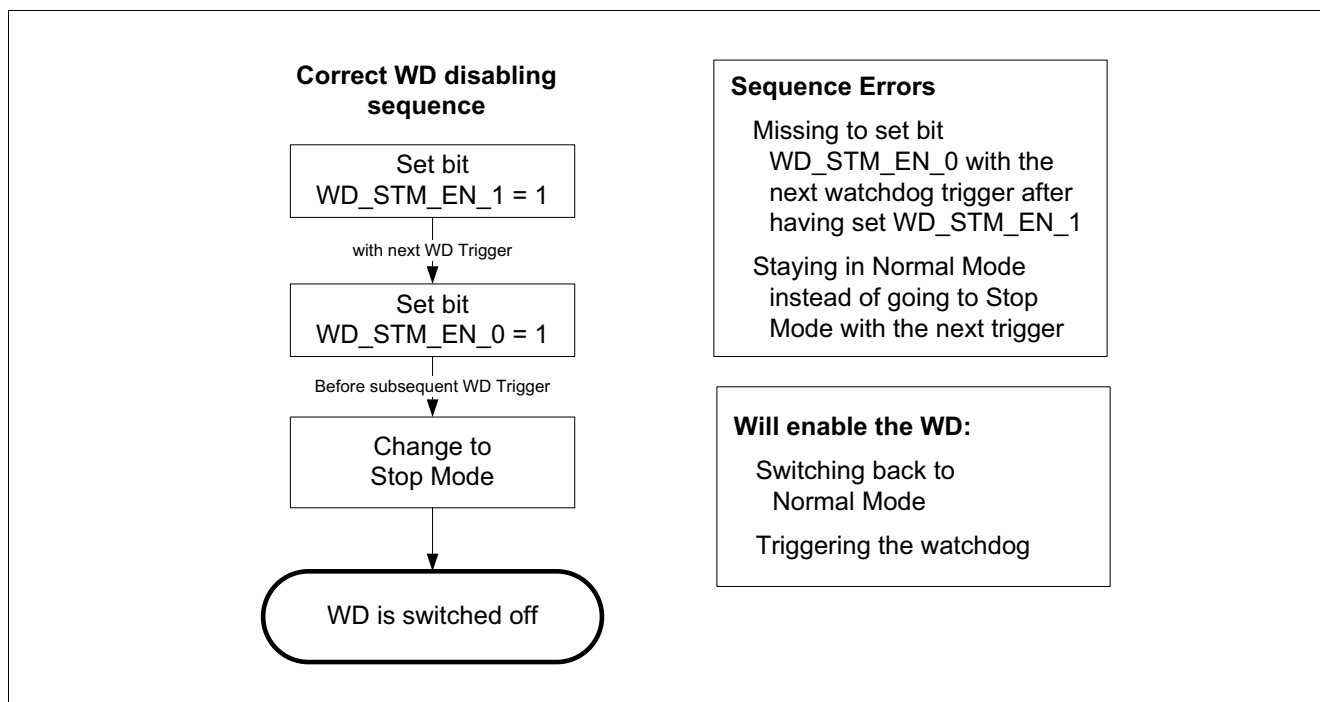

Figure 62 Watchdog disabling sequence in Stop Mode

If a sequence error occurs, then the bit [WD_STM_EN_1](#) will be cleared and the sequence has to be started again.

The watchdog can be enabled by triggering the watchdog in Stop Mode or by switching back to Normal Mode via SPI command. In both cases the watchdog will start with a long open window and the bits [WD_STM_EN_1](#) and [WD_STM_EN_0](#) are cleared. After the long open window the watchdog has to be served as configured in the [WD_CTRL](#) register.

Note: The bit [WD_STM_EN_0](#) will be cleared automatically when the sequence is started and it was 1 before. [WD_STM_EN_0](#) can also not be set if [WD_STM_EN_1](#) isn't yet set.

12.2.5 Watchdog Start in Stop Mode due to Bus Wake

In Stop Mode the Watchdog can be disabled. In addition a feature is available which will start the watchdog with any BUS wake (LIN) during Stop Mode. The feature is enabled by setting the bit [WD_EN_WK_BUS](#) = 1 (default value after POR). The bit can only be changed in Normal Mode and needs to be programmed before starting the watchdog disable sequence.

A wake on the Bus will generate an interrupt and the RXDLIN is pulled to low. By these signals the microcontroller is informed that the watchdog is started with a long open window. After the long open window the watchdog has to be served as configured in the [WD_CTRL](#) register.

To disable the watchdog again, the device needs to be switched to Normal Mode and the sequence needs to be sent again.

Supervision Functions

12.3 VSINT Power On Reset

At power up of the device, the Power on Reset is detected when $VSINT > V_{POR,r}$ and the SPI bit **POR** is set to indicate that all SPI registers are set to POR default settings. VCC1 is starting up and the reset output will be kept low and will only be released once VCC1 has crossed $V_{RT1,r}$ and after t_{RD1} has elapsed.

In case $VSINT < V_{POR,f}$, an device internal reset will be generated and the device is switched off and will restart in Init Mode at the next VSINT rising. This is shown in **Figure 63**.

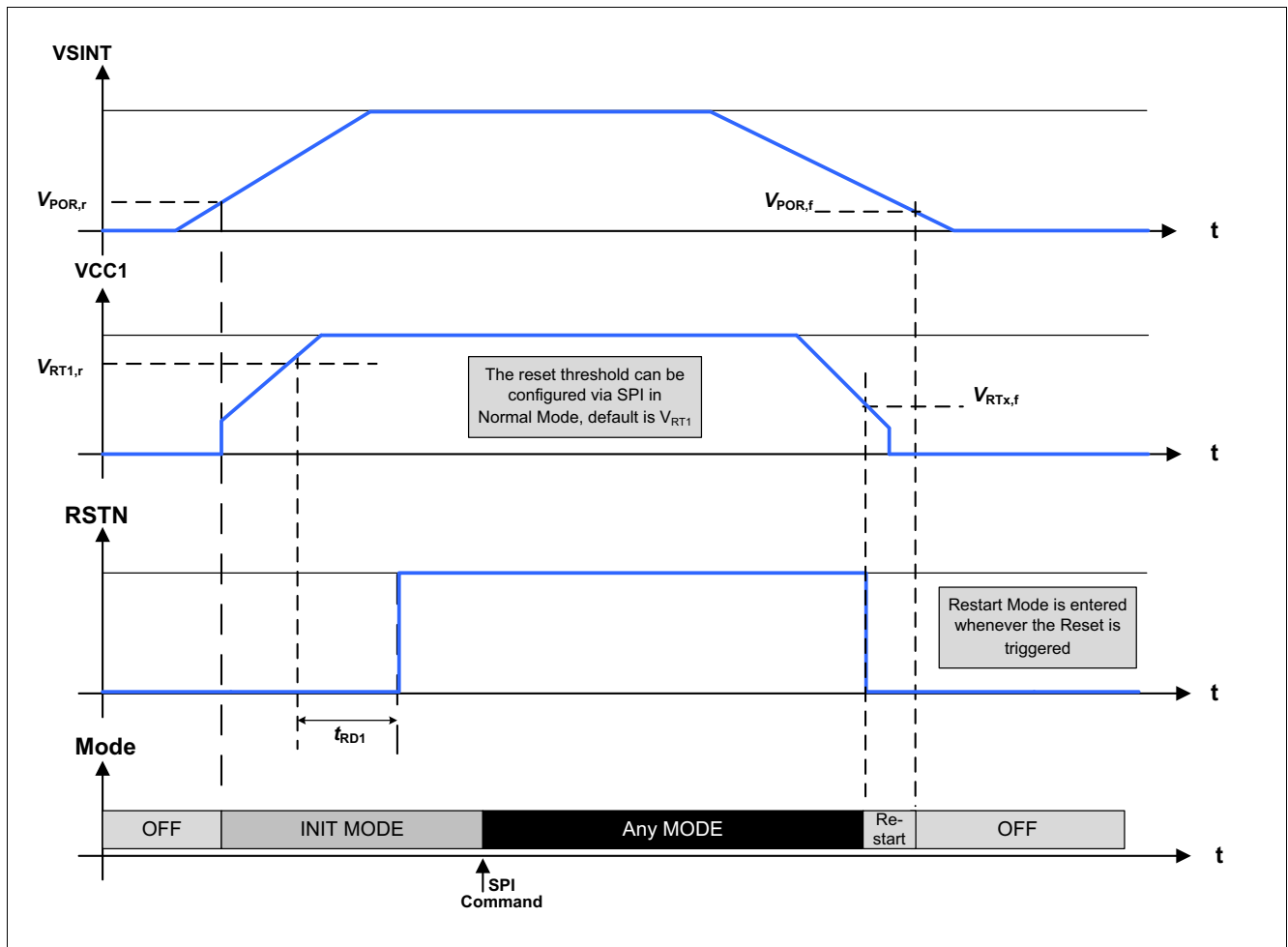

Figure 63 Ramp up / down example of Supply Voltage

12.4 VSINT Under- and Overvoltage

12.4.1 VSINT Undervoltage

The VSINT under-voltage monitoring is always active in Init Mode, Restart Mode, Normal Mode. If the supply voltage VSINT drops below $V_{SINT,UV}$ for more than t_{VSUV_FILT} , then the device does the following measures:

- The VCC1 short circuit diagnosis becomes inactive (see [Chapter 12.8](#)). However, the thermal protection of the device remains active. If the undervoltage threshold is exceeded (VSINT rising) then the function will be automatically enabled again.
- The status bit **VSINT_UV** is set and latched until a clear command of **SUP_STAT** is received.

Note: VSINT under-voltage monitoring is not available in Stop Mode due to current consumption saving requirements except if the VCC1 load current is above the active peak threshold (I_{PEAK_TH}) or if VCC1 is below the VCC1 prewarning threshold.

12.4.2 VSINT Overvoltage

The VSINT over-voltage monitoring is always active in Init Mode, Restart Mode and Normal Mode. If VSINT rises above $V_{S,OVD1}$, $V_{S,OVD2}$ for more than t_{VSOV_FILT} then the device does the following measures:

1. If HBxMODE = 01b or 10b, then the corresponding MOSFETs are actively turned off with their static discharge current during their respective tHBxCCP Active.
2. Then the charge pump is turned off and the passive discharge is activated.
3. The status bits **VSINT_OV** is set and latched until a clear command of **SUP_STAT** is received.

If VS or VSINT fall below $V_{S,OVD1}$ or $V_{S,OVD2}$:

- If **CPEN** = 0 : the charge pumps stays and the bridge driver stay off.
- If **CPEN** = 1 :
 - If **BDOV_REC** = 0 : Then the charge pump is reactivated but the bridge driver stays off until **VS_OV** and **VSINT_OV** are cleared. The current sense amplifier is reactivated (provided that **CSA_OFF** = 0)
 - If **BDOV_REC** = 1 : Then the charge pump and the current sense amplifier are reactivated and the bridge driver is enabled if $V_{CP} > V_{CPUVx}$, even if **VS_OV** or **VSINT_OV** is set. The state of the external MOSFETs is according to the control registers.

12.5 VS Under- and Overvoltage

12.5.1 VS Undervoltage

The VS under-voltage monitoring is always active in Init-, Restart Mode and Normal Mode. If VS drops below $V_{s,UV}$ for more than t_{VSUV_FILT} , then the device does the following measures:

1. If HBxMODE = 01b or 10b, then the corresponding MOSFETs are actively turned off with their static discharge current during their respective tHBxCCP Active.
2. Then the charge pump is turned off and the passive discharge is activated and the current sense amplifier is turned off.
3. The status bits **VS_UV** is set and latched until a clear command of **SUP_STAT** is received.

If VS rises above $V_{s,UV}$, then the charge pump is reactivated (provided that **CPEN** is set) and the current sense amplifier is reactivated (provided **CSA_OFF** = 0) but the bridge driver stays off until **VS_UV** is cleared. The bridge driver will be reactivated once the VS_UV bit is cleared.

12.5.2 VS Overvoltage

The VS over-voltage monitoring is always active in Init-, Restart Mode and Normal Mode or when the charge pump is enabled. If VS rises above $V_{s,OVD1}$ or $V_{s,OVD2}$ for more than $t_{VS OV_FILT}$, then the device does the following measures:

1. If HBxMODE = 01b or 10b, then the corresponding MOSFETs are actively turned off with their static discharge current during their respective tHBxCCP Active.
2. Then the charge pump is turned off and the passive discharge is activated and current sense amplifier is turned off.
3. The status bits **VS_OV** is set and latched until a clear command of **SUP_STAT** is received.

If VS and VSINT fall below $V_{s,OVD1}$ or $V_{s,OVD2}$:

- If **CPEN** = 0 : the charge pumps and the bridge driver stay off.
- If **CPEN** = 1 :
 - If **BDOV_REC** = 0 : Then the charge pump is reactivated but the bridge driver stays off until **VS_OV** and **VSINT_OV** are cleared. The current sense amplifier is reactivated provided that **CSA_OFF** = 0
 - If **BDOV_REC** = 1 : Then the charge pump and the current sense amplifier are reactivated and the bridge driver is enabled if $V_{CP} > V_{CPUVx}$, even if **VS_OV** or **VSINT_OV** is set. The state of the external MOSFETs is according to the control registers.

12.6 VS Under- Overvoltage for high-side

12.6.1 VS Undervoltage for high-side

If the supply voltage VS passes below the undervoltage threshold ($V_{SHS,UV}$) the device does the following measures:

- HS1...3 are acting accordingly to the SPI setting (refer also to [Chapter 7.2.1](#)).
- LIN: Transmitter and Receiver are disabled during the VS undervoltage condition.
- SPI bit **HS_UV** is set. No other error bits are set. The bit can be cleared once the condition is not present anymore.

12.6.2 VS Overvoltage for high-side

If the supply voltage VSHS reaches the overvoltage threshold ($V_{SHS,OVD}$) the device triggers the following measures:

- HS1...3 are acting accordingly to the SPI setting (refer also to [Chapter 7.2.2](#)).
- The status bit **HS_OV** is set. No other error bits are set. The bit can be cleared once the condition is not present anymore.

12.7 VCC1 Over-/ Undervoltage and Undervoltage Prewarning

12.7.1 VCC1 Undervoltage and Undervoltage Prewarning

This function is always active when the VCC1 voltage regulator is enabled.

A first-level voltage detection threshold is implemented as a prewarning for the microcontroller. The prewarning event is signaled with the bit **VCC1_WARN**. No other actions are taken.

As described in [Chapter 12.1](#) and [Figure 64](#), a reset will be triggered (RSTN pulled low) when the V_{CC1} output voltage falls below the selected undervoltage threshold (V_{RTx}). The device will enter Restart Mode and the bit **VCC1_UV** is set when RSTN is released again.

The hysteresis of the VCC1 undervoltage threshold can be increased by setting the bit **RSTN_HYS**. In this case always the highest rising threshold ($V_{RT1,R}$) is used for the release of the undervoltage reset. The falling reset threshold remains as configured.

An additional safety mechanism is implemented to avoid repetitive VCC1 undervoltage resets due to high dynamic loads on VCC1:

- A counter is increased for every consecutive VCC1 undervoltage event (regardless on the selected reset threshold).
- The counter is active in Init Mode, Normal Mode and Stop Mode.
- For $V_S < V_{SINT,UV}$ the counter will be stopped in Normal Mode (i.e. the VS UV comparator is always enabled in Normal Mode).
- A 4th consecutive VCC1 undervoltage event will lead to Fail-Safe Mode entry and to setting the bit **VCC1_UV_FS**.
- This counter is cleared:
 - When Fail-Safe Mode is entered.
 - When the bit **VCC1_UV** is cleared.
 - When a Soft-Reset is triggered.

Note: After 4 consecutive **VCC1_UV** events, the device will enter Fail-Safe Mode and the **VCC1_UV_FS** bit is set.

Note: The **VCC1_WARN** or **VCC1_UV** bits are not set in Sleep Mode as $V_{CC1} = 0\text{ V}$ in this case.

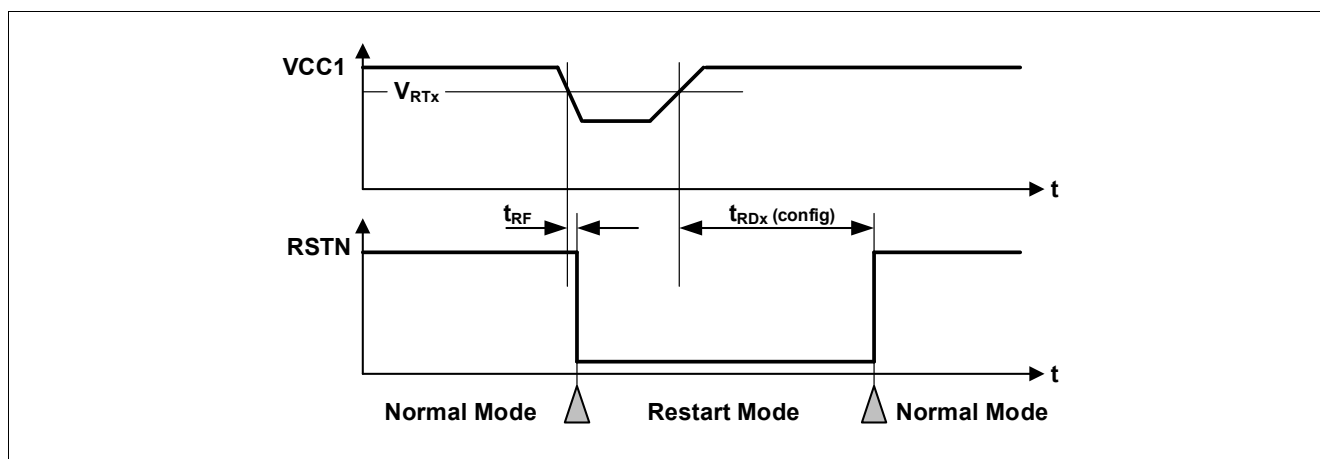

Figure 64 VCC1 Undervoltage Timing Diagram

Supervision Functions

Note: It is recommended to clear the **VCC1_WARN** and **VCC1_UV** bit once it is detected by the microcontroller software to verify if the undervoltage still exists or not.

12.7.2 VCC1 Overvoltage

For fail-safe reasons a configurable VCC1 over voltage detection feature is implemented. It is active when the VCC1 voltage regulator is enabled.

In case the $V_{CC1,OV,r}$ threshold is crossed, the device triggers following measures depending on the configuration:

- The bit **VCC1_OV** is always set.
- Based on the configuration of **VCC1_OV_MOD**, different kind of event are generated from device.
- If the **VCC1_OV_MOD**=11_B, in case of the device enters in Fail Safe Mode.

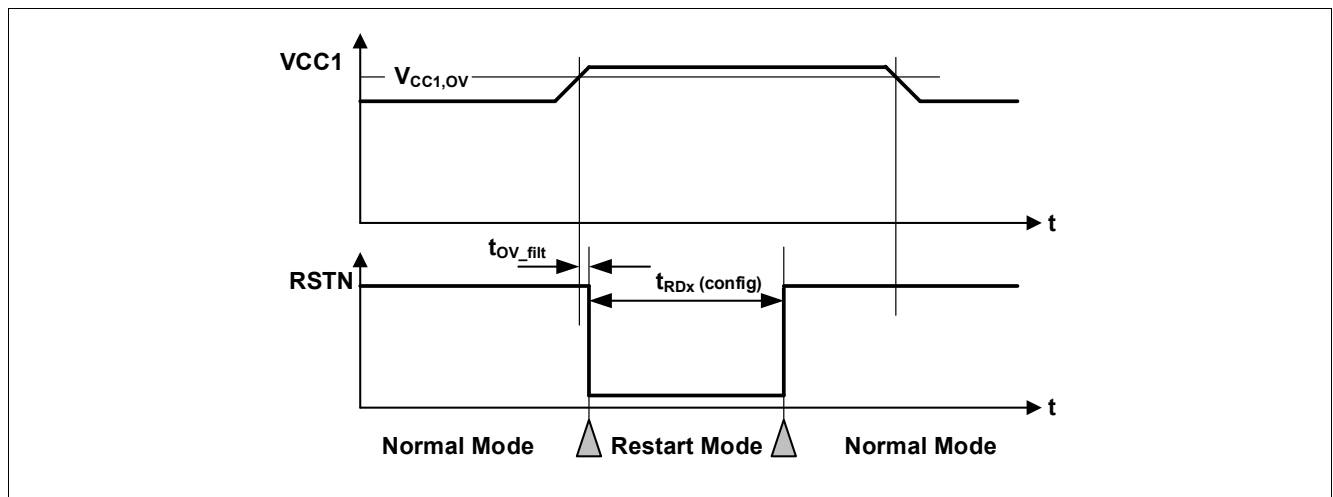

Figure 65 VCC1 Over Voltage Timing Diagram

12.8 VCC1 Short Circuit Diagnostics

The short circuit protection feature for V_{CC1} is implemented as follows:

- The short circuit detection is only enabled if $V_S > V_{SINT,UV}$.
- If V_{CC1} is not above the V_{RTX} within $t_{VCC1,SC}$ after device power up or after waking from Sleep Mode or Fail-Safe Mode (i.e. after V_{CC1} is enabled) then the SPI bit **VCC1_SC** bit is set, V_{CC1} is turned off, the FO pin is enabled, **FAILURE** is set and Fail-Safe Mode is entered. The device can be activated again via a wake-up sources.
- The same behavior applies, if V_{CC1} falls below V_{RTX} for longer than $t_{VCC1,SC}$.

12.9 Thermal Protection

Three independent and different thermal protection features are implemented in the device according to the system impact:

- Individual thermal shutdown of specific blocks
- Temperature prewarning of VCC1 voltage regulator
- Device thermal shutdown due to VCC1 overtemperature

12.9.1 Individual Thermal Shutdown

As a first-level protection measure, LIN, HSx and the charge pump are independently switched off if the respective block reaches the temperature threshold T_{jTSD1} . Then the **TSD1** bit is set. This bit can only be cleared via SPI once the overtemperature is not present anymore. Independent of the device mode the thermal shutdown protection is only active if the respective block is ON.

The respective modules behave as follows:

- LIN: The transmitter is disabled and stays in LIN Normal Mode acting like LIN Receive Only Mode. The status bits **LIN_FAIL** are set to '01'. Once the over temperature condition is not present anymore, then the LIN transmitter is automatically switched on.
- HSx: If one or more HSx switches reach the TSD1 threshold, then the HSx switches are turned OFF (depending on configuration either individually or all at once) and the control bits for HSx are cleared based on **HS_OT_SD_DIS** setting. The status bits HSx_OT are set (see register **HS_OL_OC_OT_STAT**). Once the over temperature condition is not present anymore, then HSx has to be configured again by SPI.
- Charge pump: If the charge pump reaches T_{jTSD1} , then **CP_OT** is set, **CPEN** is cleared and the activated MOSFETs are actively discharged with their respective static currents during their respective active cross current protection times (tHBxCCP active). When all tHBxCCP active elapsed, then the charge pump and the MOSFETs active discharge are disabled and the current sense amplifier is deactivated. Once the over temperature condition is not present anymore, then **CPEN** has to be configured again by SPI.

Note: The diagnosis bits are not cleared automatically and have to be cleared via SPI once the overtemperature condition is not present anymore.

12.9.2 Temperature Prewarning

As a next level of thermal protection a temperature prewarning is implemented if the main supply VCC1 reaches the thermal prewarning temperature threshold T_{jPW} . Then the status bit **TPW** is set. This bit can only be cleared via SPI once the overtemperature is not present anymore.

12.9.3 Thermal Shutdown

As a highest level of thermal protection a temperature shutdown of the device is implemented if the main supply VCC1 reaches the thermal shutdown temperature threshold T_{jTSD2} . Once a TSD2 event is detected Fail-Safe Mode is entered. Only when device temperature falls below the TSD2 threshold then the device remains in Fail-Safe Mode for t_{TSD2} to allow the device to cool down. After this time has expired, the device will automatically change via Restart Mode to Normal Mode (see also [Chapter 5.4.6](#)).

When a TSD2 event is detected, then the status bit **TSD2** is set. This bit can only be cleared via SPI in Normal Mode once the overtemperature is not present anymore.

For increased robustness requirements it is possible to extend the TSD2 waiting time by 64x of t_{TSD2} after 16 consecutive TSD2 events by setting the SPI bit **TSD2_DEL**. The counter is incremented with each TSD2 event even if the bit **TSD2** is not cleared. Once the counter has reached the value 16, then the bit **TSD2_SAFE** is set

Supervision Functions

and the extended TSD2 waiting time is active. The extended waiting time will be kept until **TSD2_SAFE** is cleared. The TSD counter is cleared when **TSD2** or **TSD2_DEL** is cleared.

Note: In case a TSD2 overtemperature occurs while entering Sleep Mode then Fail-Safe Mode is still entered.

*Note: In case of a TSD2 event, the **FAILURE** bit is set to '1' and the **DEV_STAT** field is set to '01' inside the **DEV_STAT** register.*

Supervision Functions

12.10 Bridge driver

This section describes the supervision functions related to the bridge driver.

12.10.1 Bridge driver supervision with activated charge pump

This section describes the supervision functions when the charge pump is activated.

12.10.1.1 Drain-source voltage monitoring

Voltage comparators monitor the activated MOSFETs to protect high-side MOSFETs and low-side MOSFETs against a short circuit respectively to ground and to the battery during ON-state.

A drain-source overvoltage is detected on a low-side MOSFET if the voltage difference between VSHx and SL exceeds the threshold voltage configured by **LS_VDS** (see [Table 31](#)). Consequently, the corresponding half-bridge is latched off with the static discharge current.

A drain-source overvoltage is detected on a high-side MOSFET if the voltage difference between VS and VSHx exceeds the threshold voltage configured by **HS_VDS** (see [Table 32](#)). Consequently, the corresponding half-bridge is latched off with the static discharge current.

Table 31 Low-side drain-source overvoltage threshold

LSxVDSTH[2:0]	Drain-Source overvoltage threshold for LSx (typical)
000 _B	160 mV
001 _B	200 mV (default)
010 _B	300 mV
011 _B	400 mV
100 _B	500 mV
101 _B	600 mV
110 _B	800 mV
111 _B	2 V

Table 32 High-side drain-source overvoltage threshold

HSxVDSTH[2:0]	Drain-Source overvoltage threshold for HSx (typical)
000 _B	160 mV
001 _B	200 mV (default)
010 _B	300 mV
011 _B	400 mV
100 _B	500 mV
101 _B	600 mV
110 _B	800 mV
111 _B	2 V

Attention: *2 V threshold is dedicated for the diagnostic in off-state. It is highly recommended to select another drain-source overvoltage threshold once the routine of the diagnostic in off-state has been performed to avoid additional current consumption from VS and from the charge pump.*

The device reports a Drain-Source overvoltage error if both conditions are met:

Supervision Functions

- After expiration of the blank time .
- If the Drain-Source voltage monitoring exceeds the configured threshold for a duration longer than the configured filter time (refer to [Table 33](#) and [LS_VDS](#) TFVDS bits).

Table 33 Drain-Source overvoltage filter time

TFVDS[2:0]	Drain-Source overvoltage filter time (typical)
00 _B	0.5 μs (default)
01 _B	1 μs
10 _B	2 μs
11 _B	6 μs

If a short circuit is detected by the Drain-Source voltage monitoring:

- The impacted half-bridge is latched off with the static discharge current for the configured cross-current protection time.
- The corresponding bit in the status register [DSOV](#) is set.
- The DSOV bit in Global Status Register [GEN_STAT](#) is set.

If a Drain-Source overvoltage is detected for one of the MOSFETs, then the status register [DSOV](#) must be cleared in order to re-enable the faulty half-bridge.

12.10.1.2 Cross-current protection and drain-source overvoltage blank time

All gate drivers feature a cross-current protection time and a Drain-Source overvoltage blank time.

The cross-current protection avoids the simultaneous activation of the high-side and the low-side MOSFETs of the same half-bridge.

During the blank time, the drain-source overvoltage detection is disabled, to avoid a wrong fault detection during the activation phase of a MOSFET.

Note: The setting of the cross-current protection and of the blank times may be changed by the microcontroller only if all HBx_PWM_EN bits are reset.

Note: Changing the Drain-Source overvoltage of a half-bridge x (HBx) in on-state (HBxMODE[1:0]=(0,1) or (1,0)) may result in a wrong VDS overvoltage detection on HBx. Therefore it is highly recommended to change this threshold when HBxMODE[1:0]=(0,0) or (1,1)

12.10.1.2.1 Cross-current protection

The active and freewheeling cross-current protection times of each half-bridge is configured individually with the control register [CCP_BLK](#).

The typical cross-current protection time applied to the freewheeling MOSFET of the half-bridge x is 587 ns + 266 ns x TCCP[3:0]_p, where TCCP[3:0]_p is the decimal value of the control bits TCCP.

12.10.1.2.2 Drain-source overvoltage blank time

A configurable blank time for the Drain-Source monitoring is applied at the turn-on of the MOSFETs. During the blank time, a Drain-Source overvoltage error is masked.

Supervision Functions

For Half-Bridges in PWM mode with $AFW_x = 1$:

- the blank time of the PWM MOSFET starts at the expiration of the cross-current protection time of the PWM MOSFET. Refer to [Figure 66](#).
- the blank time of the free-wheeling MOSFET starts after expiration of the cross-current protection time at turn-off of the PWM MOSFET. Refer to [Figure 66](#).

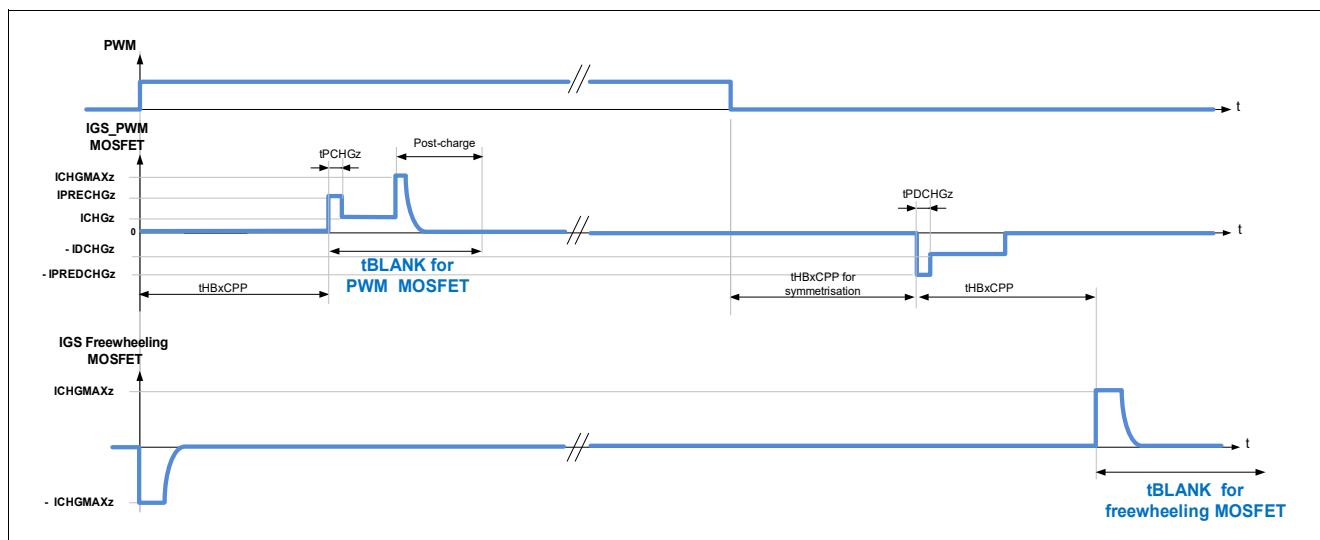

Figure 66 Blank time for half-bridges in PWM operation with $AFW = 1$

For statically activated half-bridges, the blank time starts:

- Case1: at expiration of the cross-current protection ([Figure 36](#)), if the opposite MOSFET was previously activated.
- Case 2: right after the decoding of the SPI command to turn on a MOSFET, if the half-bridge was in high impedance ([Figure 37](#)).

The blank times of the active and FW MOSFETs can be configured with the control register **CCP_BLK**.

The typical blank is $587 \text{ ns} + 266 \text{ ns} \times \text{TBLK}[3:0]_D$.

Note: The blank time is implemented at every new activation of a MOSFET, including a recovery from VS undervoltage, VS overvoltage, VSINT overvoltage, CP UV, CP OT.

12.10.1.3 OFF-state diagnostic

In order to support the off-state diagnostic ($HBxMODE = 11$ and $CPEN = 1$), the gate driver of each MOSFET provides pull-up (I_{PUDiag}) and a pull-down currents (I_{PDDiag}) at the SHx pins. This function requires an activated charge pump.

The pull-up current source of a given half-bridge is on when the half-bridge is active: $HBxMODE = 01, 10$ or 11 and $CPEN = 1$.

The pull-down current of each low-side gate driver is activated by the control bits HBx (**HB_ICHG_MAX** register).

During the off-state diagnostic routine performed by the microcontroller, the drain-source overvoltage threshold of the relevant half-bridges must be set to 2V nominal. Refer to [Table 31](#). Once the routine is finished, it is highly recommended to decrease the drain-source overvoltage threshold to a lower value, avoiding additional current consumption from the VS input.

Supervision Functions

The following failures can be detected:

- MOSFET short circuit to GND
- MOSFET short circuit the battery
- Open load (disconnected motor)

The status of the output voltages VOUTx, can be read back with status bit HBxVOUT (register **GEN_STAT**) when the corresponding half-bridge is in off-state (HBxMODE[1:0] = 11).

Note: HBxVOUT = 0 if the half-bridge x is not actively off (HBxMODE[1:0] = (0,0), (0,1) or (1,0) and **CPEN**=1) or when the charge pump is deactivated (**CPEN**=0).

12.10.1.4 Charge pump undervoltage

The voltage of the charge pump output (VCP) is monitored in order to ensure a correct control of the external MOSFETs.

The charge pump undervoltage threshold is configurable by the control bits **FET_LVL** and **CPUVTH**.

Table 34 Charge pump undervoltage thresholds

	FET_LVL = 0	FET_LVL = 1
CPUVTH = 0	V_{CPUV1} (6 V typ. referred to VS)	V_{CPUV3} (7.5 V typ. referred to VS)
CPUVTH = 1	V_{CPUV2} (6.5 V typ. referred to VS)	V_{CPUV4} (8 V typ. referred to VS)

If VCP falls below the configured charge pump undervoltage threshold while **CPEN** = 1:

- If one of the MOSFET is on, then all MOSFETs are actively turned off with their configured static discharge current during their respective tHBxCCP active.
- Then the gate drivers are turned off and CSA is turned off.
- **CP_UV** is set and latched.

The **CP_UV** is reset and the normal operation is resumed once **SUP_STAT** is cleared and VCP > VCPUV.

The charge pump undervoltage detection is blanked (**t_{CPUVBLANK}**) during each new activation of the charge pump¹⁾.

12.10.1.5 Switching parameters of MOSFETs in PWM mode

The effective switching parameters of the active MOSFETs (**EN_GEN_CHECK**=1), respectively PWM MOSFET (**EN_GEN_CHECK**=0) can be read out with dedicated status registers:

- The turn-on and turn off delays, noted tDON and tDOFF are reported by the status register **EFF_TDON_OFF1**, **EFF_TDON_OFF2**, **EFF_TDON_OFF3**.
- The rise and fall times, noted tRISE and tFALL, are reported by the status register **TRISE_FALL1**, **TRISE_FALL2**, **TRISE_FALL3**.

12.10.2 Low-side drain-source voltage monitoring during braking

The low-side MOSFETs are turned-on while the charge pump is deactivated in the following conditions:

- The slam mode is activated and PWM1/CRC is High.

1) Including **CPEN** set to 1, recovery from VS under/overvoltage, VSINT overvoltage and CP_OT

Supervision Functions

- The parking braking mode is activated and the device is in Sleep Mode or Stop Mode.
- VS overvoltage brake is activated and ($VS > VS$ Overvoltage braking or $VSINT > VSINT$ Overvoltage braking) in all device modes if **OV_BRK_EN** is set.

Under these conditions, the drain-source voltage of the low-sides are monitored and the applied drain-source overvoltage thresholds are according to **VDSTH_BRK**.

The applied blank time, which starts at the beginning of the brake activation, is:

- t_{BLK_BRAKE1} if **TBLK_BRK** = 0
- t_{BLK_BRAKE2} if **TBLK_BRK** = 1

During the blank time, a drain-source overvoltage of the low-sides is masked.

The applied filter time is t_{FVDS_BRAKE} .

If a drain-source overvoltage is detected during braking, then all low-side MOSFETs are turned off (latched) within t_{OFF_BRAKE} . **SLAM_LSx_DIS** (**BRAKE**, **SLAM**, **PARK_BRK_EN**, **OV_BRK_EN** are unchanged. The corresponding status bit LSxDISOV_BRK is set in **DSOV**.

The low-sides can be reactivated only if all LSxDISOV_BRK bits (**DSOV**) are cleared (even in slam mode with the respective LSx disabled by the **SLAM_LSx_DIS** bit).

If any of the status bits LSxDISOV_BRK is set, then the charge pump stays off (**CPEN**=1 command is accepted but the charge pump stays disabled until all LSxDISOV_BRK are cleared).

12.10.3 VS or VSINT Overvoltage braking

The VS and VSINT overvoltage braking is activated if the **OV_BRK_EN** bit in **BRAKE** register is set regardless of the device mode.

If VS, respectively VSINT, exceeds $V_{OVBR,cfgr}$ ($x = 0$ to 7), then all low-sides MOSFETs are turned-on within t_{ON_BRAKE} . The status bits **VS_OVBRAKE_ST**, respectively **VSINT_OVBRAKE_ST**, is set and latched (see **DSOV** register).

If VS and VSINT decrease below $V_{OVBR,cfgr} - V_{HYS,cfgr}$ ($x = 0$ to 7), then all low-sides MOSFETs are turned-off within t_{OFF_BRAKE} after the filter time $t_{OV_BR_FLT}$.

If ($VSHx - VSL$) exceeds the configured threshold, then all low-sides MOSFETs are turned-off within t_{OFF_BRAKE} after the filter time t_{FVDS_BRAKE} . The threshold is:

- $V_{VDSMONTH0_BRAKE}$ if **VDSTH_BRK** = 0
- $V_{VDSMONTH1_BRAKE}$ if **VDSTH_BRK** = 1

12.11 Current sense amplifier

The current sense amplifier (CSA) allows current measurements with external shunt resistor in low-side configuration. The CSA is supplied by the charge pump (CP). Therefore, if the CP is off, then the CSA is deactivated.

12.11.1 Unidirectional and bidirectional operation

The current sense amplifier (CSA) can work either as unidirectional or bi-directional operation. Refer to CSA register.

Unidirectional operation **CSD** = 0

Supervision Functions

In unidirectional operation, the CSA is optimized to measure the current flowing through the external shunt resistor when $V_{CSAP} \geq V_{CSAN}$.

$$V_{CSO} = V_{REF\ Unidir} + (V_{CSAP} - V_{CSAN} + V_{OS}) \times G_{DIFF} \text{ provided that } V_{CSO} \text{ is in the linear range}^{1) 2)}$$

Bidirectional operation **CSD = 1**

In bidirectional operation, the CSA measures the current flowing through the external shunt resistor in both directions: $V_{CSAP} \geq V_{CSAN}$ or $V_{CSAP} \leq V_{CSAN}$.

The output CSO works at half-scale range: $V_{CSO} = V_{REF\ Bidir} + (V_{CSAP} - V_{CSAN} + V_{OS}) \times G_{DIFF}$, provided that VCSO is in the linear range²⁾.

12.11.2 Gain configuration

The gain of the current sense amplifier is configurable by the configuration bits CSAG bits. Refer to [Table 35](#).

Table 35 Configuration of the current sense amplifier gain

CSAG[1:0]	Current sense amplifier gain G_{DIFF}
00 _B	G_{DIFF10}
01 _B	G_{DIFF20}
10 _B	G_{DIFF40}
11 _B	G_{DIFF60}

12.11.3 Overcurrent Detection

A comparator at CSO detects overcurrent conditions. The overcurrent threshold is configurable with the OCTH bits. Refer to [Table 36](#) for unidirectional operation and [Table 37](#) for bidirectional operation.

Table 36 Overcurrent detection thresholds in unidirectional operation (CSD = 0)

OCTH[1:0]	Typical Overcurrent Detection Threshold
00 _B	$V_{CSO} > V_{CC1}/2$
01 _B	$V_{CSO} > V_{CC1}/2 + V_{CC1}/10$
10 _B	$V_{CSO} > V_{CC1}/2 + 2 \times V_{CC1}/10$
11 _B	$V_{CSO} > V_{CC1}/2 + 3 \times V_{CC1}/10$

1) Valid if $0.5\text{ V} \leq V_{CSO} \leq V_{CC1} - 0.5\text{ V}$.

2) VCSO is clamped between VCC1 and GND.

Supervision Functions

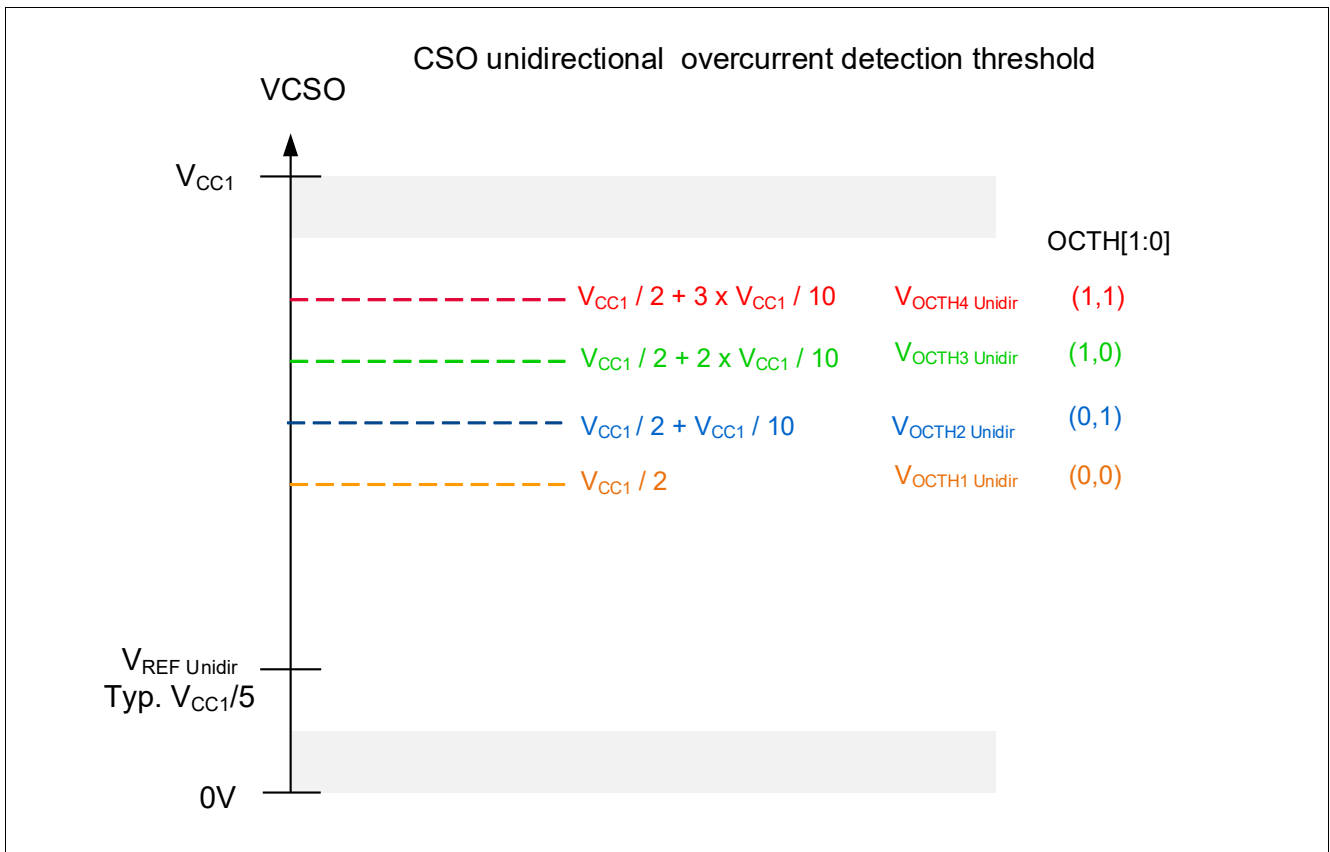

Figure 67 Overcurrent detection thresholds in unidirectional operation (CSD = 0)

Supervision Functions

Table 37 Overcurrent detection thresholds in bidirectional operation (CSD = 1)

OCTHx[1:0]	Typical Overcurrent Detection Threshold
00 _B	$V_{CSO} > V_{CC1}/2 + 2 \times V_{CC1}/20$ or $V_{CSO} < V_{CC1}/2 - 2 \times V_{CC1}/20$
01 _B	$V_{CSO} > V_{CC1}/2 + 4 \times V_{CC1}/20$ or $V_{CSO} < V_{CC1}/2 - 4 \times V_{CC1}/20$
10 _B	$V_{CSO} > V_{CC1}/2 + 5 \times V_{CC1}/20$ or $V_{CSO} < V_{CC1}/2 - 5 \times V_{CC1}/20$
11 _B	$V_{CSO} > V_{CC1}/2 + 6 \times V_{CC1}/20$ or $V_{CSO} < V_{CC1}/2 - 6 \times V_{CC1}/20$

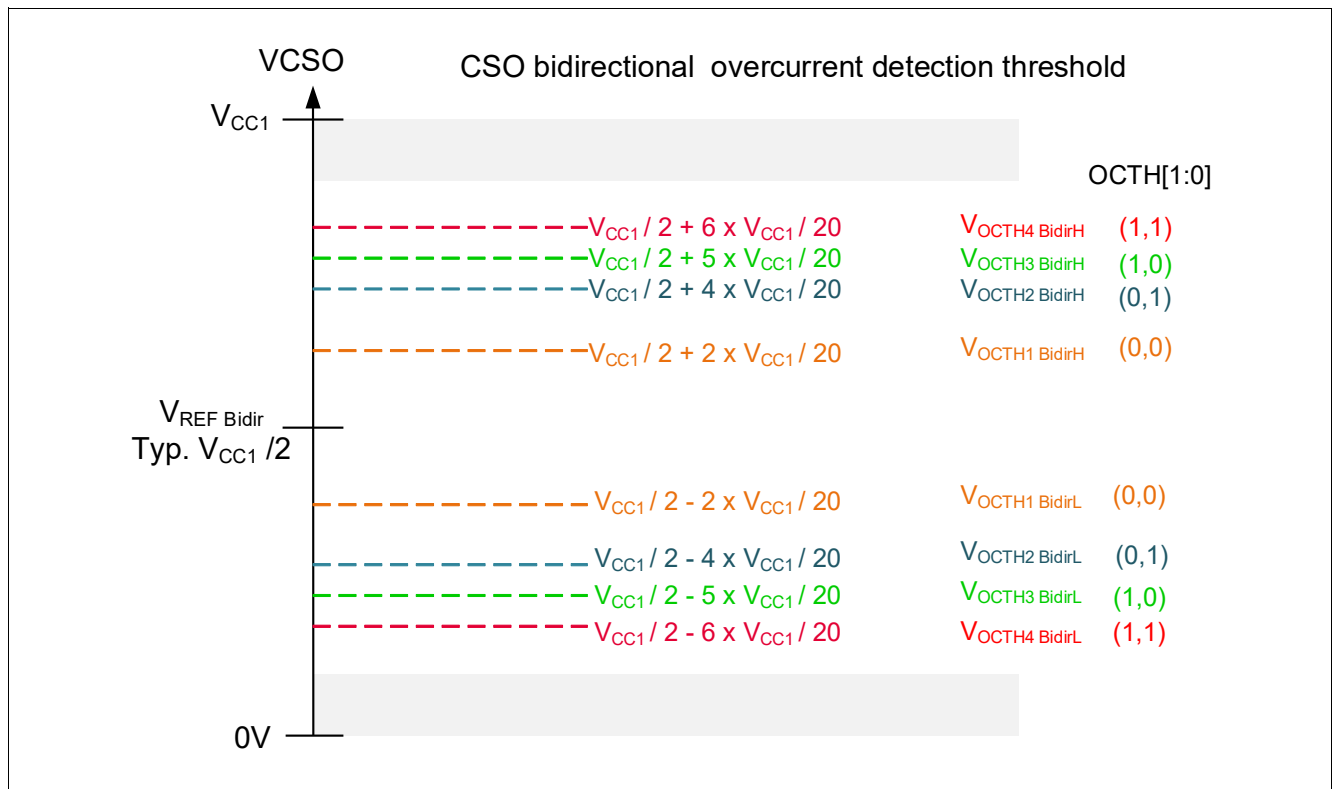

Figure 68 Overcurrent detection thresholds in bidirectional operation (CSD = 1)

It is possible to program the device behavior when an overcurrent condition is detected:

- OCEN bit = 0 (see CSA): the device only reports the overcurrent event (bit is set), without any change of the gate driver states.
- OCEN bit = 1 (see CSA): the device reports the overcurrent event (bit is set) and actively turns off all MOSFETs with static discharge current:
 - The MOSFETs can be reactivated by clearing **OC_CSA** or by resetting the **OCEN** bit.

The overcurrent filter time is configurable (refer to t_{FOC}) by the OCFILT control bits.

t_{FOC} refers to the output of the current sense amplifier. The CSO settling time ($2 \mu s$ max, t_{SET}) and the analog propagation delay ($< 1 \mu s$) are not taken into account by the overcurrent filter time.

12.11.4 CSO output capacitor

The capacitor connected to CSO (CCSO) must be between 10 pF and 2.2 nF. The control bit **CSO_CAP** optimizes the current consumption for $CCSO < 400 \text{ pF}$ or $400 \text{ pF} < CCSO < 2.2 \text{ nF}^1$.

Supervision Functions

12.12 Electrical Characteristics

Table 38 Electrical Characteristics

$V_{SINT} = 5.5 \text{ V to } 28 \text{ V}$; $T_j = -40^\circ\text{C to } +150^\circ\text{C}$; Normal Mode; all voltages with respect to ground; positive current defined flowing into pin; unless otherwise specified.

Parameter	Symbol	Values			Unit	Note or Test Condition	Number
		Min.	Typ.	Max.			
VCC1 Monitoring; VCC1 = 5.0V Version							
Undervoltage Prewarning Threshold Voltage PW,f	$V_{PW,f}$	4.53	4.70	4.84	V	VCC1 falling, SPI bit is set	P_13.12.1
Undervoltage Prewarning Threshold Voltage PW,r	$V_{PW,r}$	4.60	4.75	4.90	V	VCC1 rising	P_13.12.2
Undervoltage Prewarning Threshold Voltage hysteresis	$V_{PW,hys}$	30	50	90	mV	⁶⁾	P_13.12.3
VCC1 UV Prewarning Detection Filter Time	t_{VCC1,PW_F}	5	10	14	us	²⁾ rising and falling	P_13.12.4
Reset Threshold Voltage RT1,f	$V_{RT1,f}$	4.45	4.6	4.75	V	default setting; VCC1 falling	P_13.12.5
Reset Threshold Voltage RT1,r	$V_{RT1,r}$	4.58	4.74	4.90	V	default setting; VCC1 rising	P_13.12.6
Reset Threshold Voltage RT2,f	$V_{RT2,f}$	3.70	3.85	4.00	V	VCC1 falling	P_13.12.7
Reset Threshold Voltage RT2,r	$V_{RT2,r}$	3.85	4.0	4.15	V	VCC1 rising	P_13.12.8
Reset Threshold Voltage RT3,f	$V_{RT3,f}$	3.24	3.40	3.55	V	$V_S \geq 4 \text{ V}$; VCC1 falling	P_13.12.9
Reset Threshold Voltage RT3,r	$V_{RT3,r}$	3.39	3.54	3.70	V	$V_S \geq 4 \text{ V}$; VCC1 rising	P_13.12.10
Reset Threshold Voltage RT4,f	$V_{RT4,f}$	2.49	2.65	2.8	V	$V_S \geq 4 \text{ V}$; VCC1 falling	P_13.12.11
Reset Threshold Voltage RT4,r	$V_{RT4,r}$	2.65	2.76	2.95	V	$V_S \geq 4 \text{ V}$; VCC1 rising	P_13.12.12
Reset Threshold Hysteresis	$V_{RT,hys}$	70	140	220	mV	⁶⁾	P_13.12.13
VCC1 Over Voltage Detection Threshold Voltage	$V_{CC1,OV,r}$	5.5	5.65	5.8	V	¹⁾⁶⁾ rising VCC1	P_13.12.26
VCC1 Over Voltage Detection Threshold Voltage	$V_{CC1,OV,f}$	5.4	5.55	5.7	V	⁶⁾ falling VCC1	P_13.12.27
VCC1 OV Detection Filter Time	t_{VCC1,OV_F}	51	64	80	us	²⁾	P_13.12.31

1) for $400 \text{ pF} < \text{CCSO} < 2.2 \text{ nF}$, a seial resistor of min. 45 Ohm between the CSO pin and the CCSO capacitor is required,

Supervision Functions

Table 38 Electrical Characteristics (cont'd)

$V_{SINT} = 5.5 \text{ V to } 28 \text{ V}$; $T_j = -40^\circ\text{C to } +150^\circ\text{C}$; Normal Mode; all voltages with respect to ground; positive current defined flowing into pin; unless otherwise specified.

Parameter	Symbol	Values			Unit	Note or Test Condition	Number
		Min.	Typ.	Max.			
VCC1 Short to GND Filter Time	$t_{VCC1,SC}$	3.2	4	4.8	ms	²⁾ blanking time during power-up, short circuit detection for $V_S \geq V_{S,UV}$	P_13.12.32

Reset Generator; Pin RSTN

Reset Low Output Voltage	$V_{RSTN,L}$	–	0.2	0.4	V	$I_{RSTN} = 1 \text{ mA}$ for $V_{CC1} \geq 1 \text{ V}$ & $V_S \geq V_{POR,f}$	P_13.12.33
Reset High Output Voltage	$V_{RSTN,H}$	$0.8 \times V_{CC1}$	–	$V_{CC1} + 0.3 \text{ V}$	V	$I_{RSTN} = -20 \mu\text{A}$	P_13.12.34
Reset Pull-up Resistor	R_{RSTN}	10	20	40	k Ω	$V_{RSTN} = 0 \text{ V}$	P_13.12.35
Reset Filter Time	t_{RF}	4	10	26	μs	²⁾ $V_{CC1} < V_{RT1x}$ to RSTN = L see also Chapter 12.3	P_13.12.36
Reset Delay Time 1	t_{RD1}	8	10	12	ms	²⁾ RSTN_DEL = 0	P_13.12.37
Reset Delay Time 2	t_{RD2}	1.6	2	2.4	ms	²⁾ RSTN_DEL = 1	P_13.12.64

Watchdog Generator / Internal Oscillator

Long Open Window	t_{LW}	160	200	240	ms	²⁾	P_13.12.42
Internal Clock Generator Frequency	$f_{CLKSBC,1}$	0.8	1.0	1.2	MHz	–	P_13.12.43

Minimum Waiting time during Fail-Safe Mode

Min. waiting time Fail-Safe	$t_{FS,min}$	80	100	120	ms	²⁾³⁾	P_13.12.45
-----------------------------	--------------	----	-----	-----	----	-----------------	------------

Power-on Reset, Over / Undervoltage Protection

VSINT Power on reset rising	$V_{POR,r}$	–	–	4.5	V	VSINT increasing	P_13.12.46
VSINT Power on reset falling	$V_{POR,f}$	–	–	3	V	VSINT decreasing	P_13.12.47
VSINT Undervoltage Detection Threshold	$V_{SINT,UV}$	5.3	–	6.0	V	Supply UV threshold for VCC1 SC detection; hysteresis included; includes rising and falling threshold	P_13.12.48

Supervision Functions

Table 38 Electrical Characteristics (cont'd)

$V_{SINT} = 5.5 \text{ V to } 28 \text{ V}$; $T_j = -40^\circ\text{C to } +150^\circ\text{C}$; Normal Mode; all voltages with respect to ground; positive current defined flowing into pin; unless otherwise specified.

Parameter	Symbol	Values			Unit	Note or Test Condition	Number
		Min.	Typ.	Max.			
VSHS Overvoltage Detection Threshold	$V_{SHS,OVD}$	20	–	22	V	Supply OV supervision for HSx, LIN; hysteresis included	P_13.12.55
VSHS Overvoltage Detection hysteresis	$V_{SHS,OVD,hys}$	100	500	–	mV	⁶⁾	P_13.12.56
VSHS Undervoltage Detection Threshold	$V_{SHS,UVD}$	4.8	–	5.5	V	Supply UV supervision for HSx, LIN; hysteresis included	P_13.12.57
VSHS Undervoltage Detection hysteresis	$V_{SHS,UVD,hys}$	50	200	350	mV	⁶⁾	P_13.12.58
VSHS Undervoltage Detection Filter Time	$t_{VSHS,UV}$	5	10	14	us	²⁾ rising and falling	P_13.12.300
VSHS Overvoltage Detection Filter Time	$t_{VSHS,OV}$	5	10	14	us	²⁾ rising and falling	P_13.12.301

Charge Pump Undervoltage

Charge Pump Undervoltage Referred to VS	V_{CPUV1}	5.4	5.9	6.4	V	FET_LVL = 0 CPUVTH = 0 falling threshold, VS ≥ 6 V	P_13.12.59
Charge Pump Undervoltage Referred to VS	V_{CPUV2}	5.85	6.35	6.85	V	FET_LVL = 0 CPUVTH = 1 falling threshold, VS ≥ 6 V	P_13.12.60
Charge Pump Undervoltage Referred to VS	V_{CPUV3}	6.85	7.35	7.85	V	FET_LVL = 1 CPUVTH = 0 falling threshold, VS ≥ 6 V	P_13.12.61
Charge Pump Undervoltage Referred to VS	V_{CPUV4}	7.5	8	8.5	V	FET_LVL = 1 CPUVTH = 1 falling threshold, VS ≥ 6 V	P_13.12.62
Charge Pump Undervoltage Filter Time	t_{CPUV}	51	64	80	μs	⁶⁾ VS ≥ 6 V	P_13.12.63
Charge Pump Undervoltage Blank Time	$t_{CPUVBLANK}$	400	500	600	μs	⁶⁾ VS ≥ 6 V	P_13.12.175

VS monitoring

Supervision Functions

Table 38 Electrical Characteristics (cont'd)

$V_{SINT} = 5.5 \text{ V to } 28 \text{ V}$; $T_j = -40^\circ\text{C to } +150^\circ\text{C}$; Normal Mode; all voltages with respect to ground; positive current defined flowing into pin; unless otherwise specified.

Parameter	Symbol	Values			Unit	Note or Test Condition	Number
		Min.	Typ.	Max.			
VS undervoltage threshold	$V_{S,UV}$	4.7	–	5.4	V	hysteresis included	P_13.12.66
VS overvoltage threshold detection 1	$V_{S,OVD1}$	19	–	22.5	V	hysteresis included, VS_OV_SEL = 0	P_13.12.68
VS overvoltage threshold detection 2	$V_{S,OVD2}$	27.75	–	31.25	V	hysteresis included, VS_OV_SEL = 1	P_13.12.65
VS undervoltage filter time	t_{VSUV_FILT}	5	10	14	μs	²⁾ rising and falling	P_13.12.71
VS overvoltage filter time	t_{VSOV_FILT}	5	10	14	μs	²⁾ rising and falling	P_13.12.72

Off-state open load diagnosis

Pull-up diagnosis current	I_{PUDiag}	-600	-400	-270	μA	$VS \geq 6 \text{ V}$	P_13.12.73
Pull-down diagnosis current	I_{PDDiag}	1600	2200	2800	μA	$VS \geq 6 \text{ V}$	P_13.12.74
Diagnosis current ratio	I_{Diag_ratio}	4.25	5.25	6.25		Ratio I_{PDDiag} / I_{PUDiag}	P_13.12.302

Drain-source monitoring CP activated

Blank time	t_{BLANK}	typ-20%	587 +266 \times TBLK	typ+20%	ns	⁶⁾ TBLK: decimal value of TBLK[3:0], $VS \geq 6 \text{ V}$	P_13.12.75
Cross-current protection time	t_{CCP}	typ-20%	587 +266 \times TCCP	typ+20%	ns	⁶⁾ TCCP: decimal value of TCCPx[3:0], $VS \geq 6 \text{ V}$	P_13.12.76
HS/LS Drain-source overvoltage 0	$V_{VDSMONTH0_CPON}$	0.115	0.16	0.195	V	$VDSTH[2:0] = 000_B$, $VS \geq 6 \text{ V}$, $TFVDS = 00_B$	P_13.12.77
HS/LS Drain-source overvoltage 1	$V_{VDSMONTH1_CPON}$	0.16	0.2	0.25	V	$VDSTH[2:0] = 001_B$, $VS \geq 6 \text{ V}$, $TFVDS = 00_B$	P_13.12.78
HS/LS Drain-source overvoltage 2	$V_{VDSMONTH2_CPON}$	0.24	0.3	0.36	V	$VDSTH[2:0] = 010_B$, $VS \geq 6 \text{ V}$, $TFVDS = 00_B$	P_13.12.79
HS/LS Drain-source overvoltage 3	$V_{VDSMONTH3_CPON}$	0.32	0.4	0.48	V	$VDSTH[2:0] = 011_B$, $VS \geq 6 \text{ V}$, $TFVDS = 00_B$	P_13.12.80
HS/LS Drain-source overvoltage 4	$V_{VDSMONTH4_CPON}$	0.4	0.5	0.6	V	$VDSTH[2:0] = 100_B$, $VS \geq 6 \text{ V}$, $TFVDS = 00_B$	P_13.12.81
HS/LS Drain-source overvoltage 5	$V_{VDSMONTH5_CPON}$	0.48	0.6	0.72	V	$VDSTH[2:0] = 101_B$, $VS \geq 6 \text{ V}$, $TFVDS = 00_B$	P_13.12.82
HS/LS Drain-source overvoltage 6	$V_{VDSMONTH6_CPON}$	0.64	0.8	0.96	V	$VDSTH[2:0] = 110_B$, $VS \geq 6 \text{ V}$, $TFVDS = 00_B$	P_13.12.83

Supervision Functions

Table 38 Electrical Characteristics (cont'd)

$V_{SINT} = 5.5 \text{ V to } 28 \text{ V}$; $T_j = -40^\circ\text{C to } +150^\circ\text{C}$; Normal Mode; all voltages with respect to ground; positive current defined flowing into pin; unless otherwise specified.

Parameter	Symbol	Values			Unit	Note or Test Condition	Number
		Min.	Typ.	Max.			
HS/LS Drain-source overvoltage 7	$V_{VDSMONTH7_CPON}$	1.75	2.0	2.25	V	$VDSTH[2:0] = 111_B$, $VS \geq 6 \text{ V}$, $TFVDS = 00_B$	P_13.12.84

Drain-Source monitoring - Slam mode, parking braking and VS overvoltage braking, VS or VSINT $\geq 8 \text{ V}$

Blank time	t_{BLK_BRAKE1}	4.5	7	9.5	μs	TBLK_BRK = 0 , VS or $VSINT \geq 8 \text{ V}$	P_13.12.85
Blank time	t_{BLK_BRAKE2}	9	11	13	μs	TBLK_BRK = 1 , VS or $VSINT \geq 8 \text{ V}$	P_13.12.86
VDS Filter time	t_{FVDS_BRAKE}	0.5	1	2.5	μs	VS or $VSINT \geq 8 \text{ V}$	P_13.12.87
LS Drain-source monitoring thresholds	$V_{VDSMONTH0_BRAKE}$	0.56	0.8	1.05	V	VS or $VSINT \geq 8 \text{ V}$ VDSTH_BRK = 0	P_13.12.89
LS Drain-source monitoring thresholds	$V_{VDSMONTH1_BRAKE}$	0.15	0.22	0.29	V	VS or $VSINT \geq 8 \text{ V}$ VDSTH_BRK = 1	P_13.12.90

VS Overvoltage Braking Mode

VS Overvoltage braking config 0 rising	$V_{OVBR, cfg0, r}$	25.65	27	28.35	V	OV_BRK_TH=000_B	P_13.12.97
VS Overvoltage braking config 1 rising	$V_{OVBR, cfg1, r}$	26.60	28	29.40	V	OV_BRK_TH=001_B	P_13.12.98
VS Overvoltage braking config 2 rising	$V_{OVBR, cfg2, r}$	27.55	29	30.45	V	OV_BRK_TH=010_B	P_13.12.99
VS Overvoltage braking config 3 rising	$V_{OVBR, cfg3, r}$	28.50	30	31.50	V	OV_BRK_TH=011_B	P_13.12.100
VS Overvoltage braking config 4 rising	$V_{OVBR, cfg4, r}$	29.45	31	32.55	V	OV_BRK_TH=100_B	P_13.12.101
VS Overvoltage braking config 5 rising	$V_{OVBR, cfg5, r}$	30.40	32	33.60	V	OV_BRK_TH=101_B	P_13.12.102
VS Overvoltage braking config 6 rising	$V_{OVBR, cfg6, r}$	31.35	33	34.65	V	OV_BRK_TH=110_B	P_13.12.103
VS Overvoltage braking config 7 rising	$V_{OVBR, cfg7, r}$	32.30	34	35.70	V	OV_BRK_TH=111_B	P_13.12.104
VS Overvoltage braking config 0	$V_{HYS, cfg0}$	0.64	0.75	0.85	V	OV_BRK_TH=000_B	P_13.12.105
VS Overvoltage braking config 1	$V_{HYS, cfg1}$	0.74	0.82	0.9	V	OV_BRK_TH=001_B	P_13.12.109
VS Overvoltage braking config 2	$V_{HYS, cfg2}$	0.80	0.89	0.98	V	OV_BRK_TH=010_B	P_13.12.113
VS Overvoltage braking config 3	$V_{HYS, cfg3}$	0.85	0.95	1.05	V	OV_BRK_TH=011_B	P_13.12.117
VS Overvoltage braking config 4	$V_{HYS, cfg4}$	0.93	1.03	1.13	V	OV_BRK_TH=100_B	P_13.12.121

Supervision Functions

Table 38 Electrical Characteristics (cont'd)

$V_{SINT} = 5.5 \text{ V to } 28 \text{ V}$; $T_j = -40^\circ\text{C to } +150^\circ\text{C}$; Normal Mode; all voltages with respect to ground; positive current defined flowing into pin; unless otherwise specified.

Parameter	Symbol	Values			Unit	Note or Test Condition	Number
		Min.	Typ.	Max.			
VS Overvoltage braking config 5	$V_{HYS,cf5}$	0.97	1.08	1.19	V	OV_BRK_TH=101_B	P_13.12.125
VS Overvoltage braking config 6	$V_{HYS,cf6}$	1.03	1.15	1.27	V	OV_BRK_TH=110_B	P_13.12.129
VS Overvoltage braking config 7	$V_{HYS,cf7}$	1.1	1.23	1.36	V	OV_BRK_TH=111_B	P_13.12.133
VS and VSINT overvoltage braking filter time	$t_{OV_BR_FLT}$	10	15	20	μs	⁶⁾	P_13.12.200

Current sense amplifier⁴⁾

Operating common mode input voltage range referred to GND (CSAP - GND) or (CSAN- GND)	V_{CM}	-2.0	-	2.0	V		P_13.12.138
Common Mode Rejection Ratio	CMRR	63 69 75 77	- - - -	- - - -	dB	⁶⁾ CSAG = (0,0) CSAG = (0,1) CSAG = (1,0) CSAG = (1,1) DC to 50 kHz $V_{CM} = -2 \dots 2 \text{ V}$ $V_{CSAP} = V_{CSAN}$	P_13.12.139
Settling time to 98%	t_{SET}	-	1500	2000	ns	⁶⁾	P_13.12.140
Settling time to 98% after gain change	t_{SET_GAIN}	-	-	5000	ns	⁶⁾ After gain change from CSN rising edge	P_13.12.141
Input Offset voltage	V_{OS}	-1	0	1	mV		P_13.12.142
Current Sense Amplifier DC Gain (uncalibrated)	G_{DIFF10}	9.91	10.04	10.17	V/V	CSAG = (0,0)	P_13.12.143
Current Sense Amplifier DC Gain (uncalibrated)	G_{DIFF20}	19.79	20.05	20.31	V/V	CSAG = (0,1)	P_13.12.144
Current Sense Amplifier DC Gain (uncalibrated)	G_{DIFF40}	39.53	40.05	40.57	V/V	CSAG = (1,0)	P_13.12.145
Current Sense Amplifier DC Gain (uncalibrated)	G_{DIFF60}	59.34	60.12	60.91	V/V	CSAG = (1,1)	P_13.12.146
Gain drift	G_{DRIFT}	-0.5	-	0.5	%	⁶⁾ Gain drift after calibration	P_13.12.151
CSO single ended output voltage range (linear range)	V_{CSO}	0.5	-	$V_{CC1} - 0.5$	V	⁶⁾	P_13.12.152
Reference voltage for unidirectional CSAx	$V_{REF \text{ Unidir}}$	-1.25%	$V_{CC1}/5$	+1.25%	V	CSD = 0 $V_{CSAP} = V_{CSAN}$	P_13.12.153

Supervision Functions

Table 38 Electrical Characteristics (cont'd)

$V_{SINT} = 5.5\text{ V to }28\text{ V}$; $T_j = -40^\circ\text{C to }+150^\circ\text{C}$; Normal Mode; all voltages with respect to ground; positive current defined flowing into pin; unless otherwise specified.

Parameter	Symbol	Values			Unit	Note or Test Condition	Number
		Min.	Typ.	Max.			
Reference voltage for bidirectional CSAx	$V_{REF\ Bidir}$	-1%	$V_{CC1}/2$	+1%	V	CSD = 1 $V_{CSAP} = V_{CSAN}$	P_13.12.154

Overcurrent detection

Overcurrent filter time	t_{FOC}	4 7 40 80	6 10 50 100	8 13 60 120	μs	⁵⁾⁶⁾ OCFILT = 00 _B OCFILT = 01 _B OCFILT = 10 _B OCFILT = 11 _B	P_13.12.155
OC threshold, unidirectional	$V_{OCTH1\ Unidir}$	-4%	$V_{CC1}/2$	+4%	V	CSD = 0, OCTH[1:0] = 00 _B	P_13.12.156
OC threshold, unidirectional	$V_{OCTH2\ Unidir}$	-4%	$V_{CC1}/2$ + $V_{CC1}/10$	+4%	V	CSD = 0, OCTH[1:0] = 01 _B	P_13.12.157
OC threshold, unidirectional	$V_{OCTH3\ Unidir}$	-4%	$V_{CC1}/2$ + 2x $V_{CC1}/10$	+4%	V	CSD = 0, OCTH[1:0] = 10 _B	P_13.12.158
OC threshold, unidirectional	$V_{OCTH4\ Unidir}$	-4%	$V_{CC1}/2$ + 3x $V_{CC1}/10$	+4%	V	CSD = 0, OCTH[1:0] = 11 _B	P_13.12.159
High OC threshold, bidirectional	$V_{OCTH1\ BidirH}$	-4%	$V_{CC1}/2$ + 2x $V_{CC1}/20$	+4%	V	CSD = 1, OCTH[1:0] = 00 _B	P_13.12.160
High OC threshold, bidirectional	$V_{OCTH2\ BidirH}$	-4%	$V_{CC1}/2$ + 4x $V_{CC1}/20$	+4%	V	CSD = 1, OCTH[1:0] = 01 _B	P_13.12.161
High OC threshold, bidirectional	$V_{OCTH3\ BidirH}$	-4%	$V_{CC1}/2$ + 5x $V_{CC1}/20$	+4%	V	CSD = 1, OCTH[1:0] = 10 _B	P_13.12.162
High OC threshold, bidirectional	$V_{OCTH4\ BidirH}$	-4%	$V_{CC1}/2$ + 6x $V_{CC1}/20$	+4%	V	CSD = 1, OCTH[1:0] = 11 _B	P_13.12.163
Low OC threshold, bidirectional	$V_{OCTH1\ BidirL}$	-4%	$V_{CC1}/2$ - 2x $V_{CC1}/20$	+4%	V	CSD = 1, OCTH[1:0] = 00 _B	P_13.12.164
Low OC threshold, bidirectional	$V_{OCTH2\ BidirL}$	-4%	$V_{CC1}/2$ - 4x $V_{CC1}/20$	+4%	V	CSD = 1, OCTH[1:0] = 01 _B	P_13.12.165
Low OC threshold, bidirectional	$V_{OCTH3\ BidirL}$	-4%	$V_{CC1}/2$ - 5x $V_{CC1}/20$	+4%	V	CSD = 1, OCTH[1:0] = 10 _B	P_13.12.166

Supervision Functions

Table 38 Electrical Characteristics (cont'd)

$V_{SINT} = 5.5 \text{ V to } 28 \text{ V}$; $T_j = -40^\circ\text{C to } +150^\circ\text{C}$; Normal Mode; all voltages with respect to ground; positive current defined flowing into pin; unless otherwise specified.

Parameter	Symbol	Values			Unit	Note or Test Condition	Number
		Min.	Typ.	Max.			
Low OC threshold, bidirectional	$V_{OCTH4 \text{ BidirL}}$	-4%	$V_{CC1}/2 - 6x$ $V_{CC1}/20$	+4%	V	CSD = 1, OCTH[1:0]= 11 _B	P_13.12.167

Current Sense Amplifier Dynamic Parameters

Power Supply Rejection Ratio	PSRR	60	-	-	dB	⁶⁾ VCP modulated with sinewave (100 kHz, 1 Vpp)	P_13.12.168
------------------------------	------	----	---	---	----	--	-------------

Overtemperature Shutdown⁶⁾

Thermal Prewarning Temperature	T_{jPW}	125	145	165	°C	T_j rising	P_13.12.169
Thermal Shutdown TSD1	T_{jTSD1}	170	185	200	°C	T_j rising	P_13.12.170
Thermal Shutdown TSD2	T_{jTSD2}	170	185	200	°C	T_j rising	P_13.12.171
Thermal Shutdown hysteresis	$T_{jTSD,hys}$	-	25	-	°C	⁶⁾	P_13.12.172
TSD/TPW Filter Time	$t_{TSD_TPW_F}$	5	10	15	us	rising and falling, applies to all thermal sensors (TPW, TSD1, TSD2)	P_13.12.173
Deactivation time after thermal shutdown TSD2	t_{TSD2}	0.8	1	1.2	s	²⁾	P_13.12.174

1) It is ensured that the threshold $V_{CC1,OV,r}$ is always higher than the highest regulated V_{CC1} output voltage $V_{CC1,out4}$.

2) Not subject to production test, tolerance defined by internal oscillator tolerance.

3) This time applies for all failure entries except a device thermal shutdown (TSD2 has a typ. 1 s waiting time t_{TSD2}).

4) $6 \text{ V} \leq V_S \leq 23 \text{ V}$

5) t_{FOC} refers to the output of the current sense amplifier. The CSO settling time (2 μs max, t_{SET}) and the analog propagation delay (< 1 μs) are not taken into account by the overcurrent filter time.

6) Not subject to production test, specified by design.

Serial Peripheral Interface

13 Serial Peripheral Interface

The Serial Peripheral Interface is the communication link between the device and the microcontroller. The TLE9564QX is supporting multi-slave operation in full-duplex mode with 32-bit data access.

The SPI behavior for the different device modes is as follows:

- The SPI is enabled in Init Mode, Normal Mode and Stop Mode.
- The SPI is OFF in Sleep Mode, Restart Mode and Fail-Safe Mode.

13.1 SPI Block Description

The Control Input Word is read via the data input SDI, which is synchronized with the clock input CLK provided by the microcontroller. The output word appears synchronously at the data output SDO (see Figure 69 with a 32-bit data access example).

The transmission cycle begins when the chip is selected by the input CSN (Chip Select Not), LOW active. After the CSN input returns from LOW to HIGH, the word that has been read is interpreted according to the content. The SDO output switches to tristate status (high impedance) at this point, thereby releasing the SDO bus for other use. The state of SDI is shifted into the input register with every falling edge on CLK. The state of SDO is shifted out of the output register after every rising edge on CLK. The SPI of the device is not daisy chain capable.

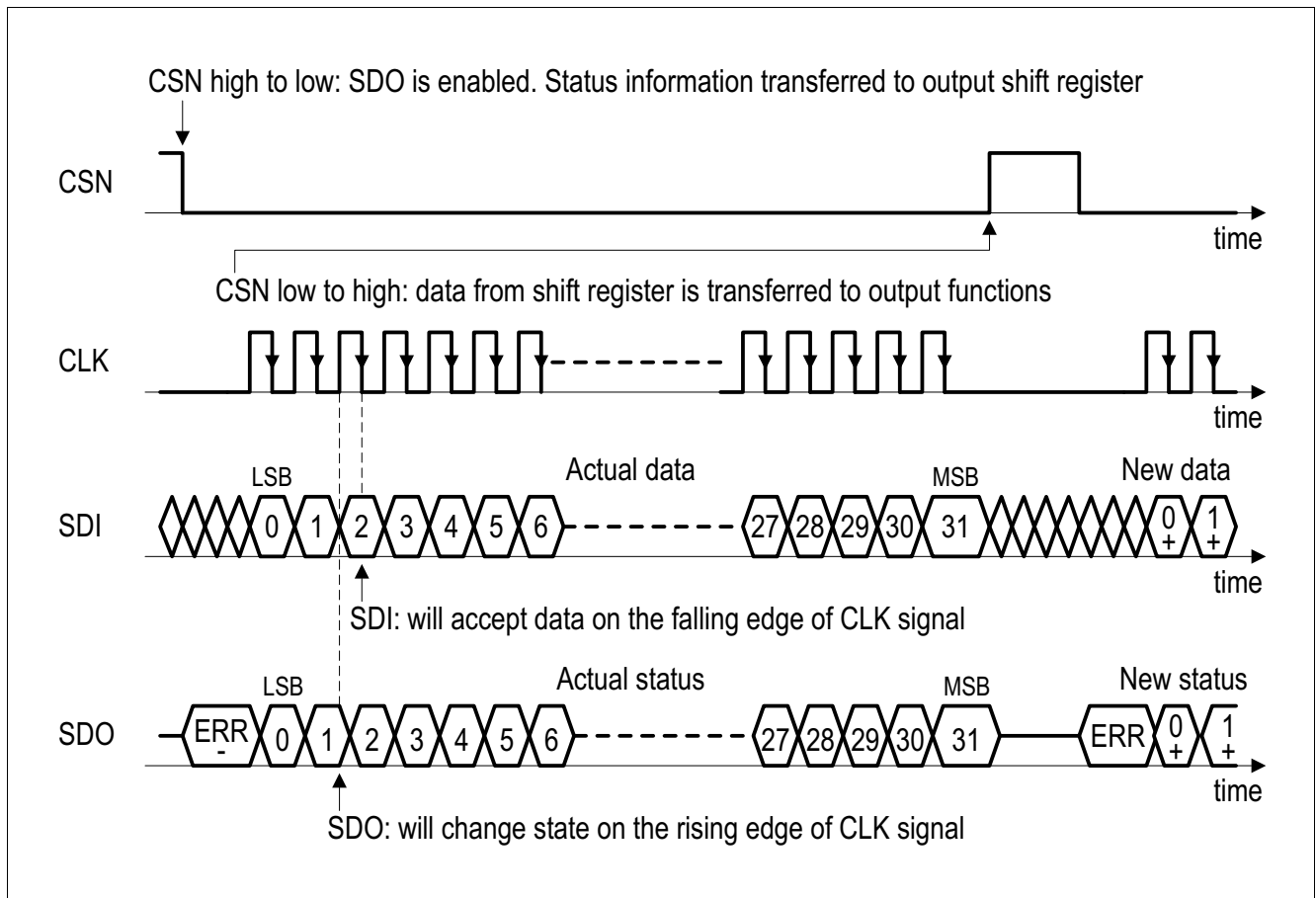

Figure 69 SPI Data Transfer Timing (note the reversed order of LSB and MSB shown in this figure compared to the register description)

13.2 Failure Signalization in the SPI Data Output

When the microcontroller sends a wrong SPI command to the device, the device ignores the information. Wrong SPI commands are either invalid device mode commands or commands which are prohibited by the state machine to avoid undesired device or system states (see below). In this case the diagnosis bit **SPI_FAIL** is set and the SPI Write command is ignored (no partial interpretation). This bit can be only reset by actively clearing it via a SPI command.

Invalid SPI Commands leading to SPI_FAIL are listed below (in this case the SPI command is ignored):

- Illegal state transitions:
 - Going from Stop Mode to Sleep Mode. In this case the device enters Restart Mode.
 - Trying to go to Stop Mode or Sleep Mode from Init Mode¹⁾. In this case Normal Mode is entered.
- Uneven parity in the data bit of the **WD_CTRL** register. In this case the watchdog trigger is ignored and/or the new watchdog settings are ignored respectively.
- In Stop Mode: attempting to change any SPI settings, e.g. changing the watchdog configuration, PWM settings and HSx configuration settings during Stop Mode, etc.; the SPI command is ignored in this case; only WD trigger, returning to Normal Mode, triggering a device soft reset, and read & clear status registers commands are valid SPI commands in Stop Mode; **Note:** No failure handling is done for the attempt to go to Stop Mode when all bits in the registers **BUS_CTRL** and **WK_CTRL** are cleared because the microcontroller can leave this mode via SPI.
- When entering Stop Mode and **WK_STAT** is not cleared; **SPI_FAIL** will not be set but the INTN pin will be triggered.
- Changing from Stop Mode to Normal Mode and changing the other bits of the **M_S_CTRL** register. The other modifications will be ignored.
- Sleep Mode: attempt to go to Sleep Mode without any wake source set, i.e. when all bits in the **BUS_CTRL** and **WK_CTRL** registers are cleared. In this case the **SPI_FAIL** bit is set and the device enters Restart Mode. Even though the Sleep Mode command is not entered in this case, the rest of the command is executed but restart values apply during Restart Mode; **Note:** At least one wake source must be activated in order to avoid a deadlock situation in Sleep Mode. If the only wake source is a timer and the timer is OFF, then the device will wake immediately from Sleep Mode and enter Restart Mode.
- Setting a longer or equal on-time than the timer period of the respective timer.
- SDI stuck at HIGH or LOW, e.g. SDI received all '0' or all '1'.
- Configured the HSx controlled by SYNC when the WK4/SYNC is not configured as SYNC-input.

Note: There is no SPI fail information for unused addresses.

*Note: In case that the register or banking are accessed but they are not valid as address or banks, the **SPI_FAIL** is not triggered and the cmd is ignored.*

Signalization of the ERR Flag (high active) in the SPI Data Output (see Figure 69):

The ERR flag presents an additional diagnosis possibility for the SPI communication. The ERR flag is being set for following conditions:

1) If the device is externally configured to use SPI with CRC (by PWM1/CRC pin), the attempt to go to Stop or Sleep from Init, will generate SPI_FAIL even if it is a SPI command with correct CRC. Still, the first SPI command will put the device from Init to Normal Mode even if CRC is not correct (CRC_FAIL status bit will be set).

Serial Peripheral Interface

- in case the number of received SPI clocks is not 0 or 32.
- in case RSTN is LOW and SPI frames are being sent at the same time.

Note: In order to read the SPI ERR flag properly, CLK must be low when CSN is triggered, i.e. the ERR bit is not valid if the CLK is high on a falling edge of CSN.

The number of received SPI clocks is not 0 or 32:

The number of received input clocks is supervised to be 0 or 32 clock cycles and the input word is discarded in case of a mismatch (0 clock cycle to enable ERR signalization). The error logic also recognizes if CLK was high during CSN edges. Both errors (0 or 32 bit CLK mismatch or CLK high during CSN edges) are flagged in the following SPI output by a “HIGH” at the data output (SDO pin, bit ERR) before the first rising edge of the clock is received. The complete SPI command is ignored in this case.

RSTN is LOW and SPI frames are being sent at the same time:

The ERR flag will be set when the RSTN pin is triggered (during device restart) and SPI frames are being sent to the device at the same time. The behavior of the ERR flag will be signalized at the next SPI command for below conditions:

- If the command begins when RSTN is HIGH and it ends when RSTN is LOW.
- If a SPI command will be sent while RSTN is LOW.
- If a SPI command begins when RSTN is LOW and it ends when RSTN is HIGH.

And the SDO output will behave as follows:

- Always when RSTN is LOW then SDO will be HIGH.
- When a SPI command begins when RSTN is LOW and ends when RSTN is HIGH, then the SDO should be ignored because wrong data will be sent.

Note: It is possible to quickly check for the ERR flag without sending any data bits. i.e. only the CSN is pulled low and SDO is observed - no SPI Clocks are sent in this case.

Note: The ERR flag could also be set after the device has entered Fail-Safe Mode because the SPI communication is stopped immediately.

13.3 SPI Programming

For the TLE9564QX, 7 bits are used for the address selection (BIT 6...0). Bit 7 is used to decide between Read Only and Read & Clear for the status bits, and between Write and Read Only for configuration bits. For the actual configuration and status information, 16 data bits (BIT 23...8) are used.

Writing, clearing and reading is done word wise. The SPI status bits are not cleared automatically and must be cleared by the microcontroller. Some of the configuration bits will automatically be cleared by the device (refer to the respective register descriptions for detailed information). In Restart Mode, the device ignores all SPI communication, i.e. it does not interpret it.

There are two types of SPI registers:

- Control registers: These registers are used to configure the device, e.g. mode, watchdog trigger, etc.
- Status registers: These registers indicate the status of the device, e.g. wake events, warnings, failures, etc.

For the status registers, the requested information is given in the same SPI command in the data out (SDO). For the control registers, the status of each byte is shown in the same SPI command as well. However, configuration changes of the same register are only shown in the next SPI command (configuration changes inside the device become valid only after CSN changes from low to high). See [Figure 70](#).

Writing of control registers is possible in Init and Normal Mode. During Stop Mode only the change to Normal Mode and triggering the watchdog is allowed as well as reading and clearing the status registers.

No status information can be lost, even if a bit changes right after the first 7 SPI clock cycles before the SPI frame ends. In this case the status information field will be updated with the next SPI command. However, the flag is already set in the relevant status register. The device status information from the SPI status registers is transmitted in a compressed format with each SPI response on SDO in the so-called Status Information Field register (see also [Table 39](#)). The purpose of this register is to quickly signal changes in dedicated SPI status registers to the microcontroller.

Table 39 Status Information Field

Bit in Status Information Field	Corresponding Address Bit	Status Register Description
0		SUPPLY_STAT = OR of all bits on SUP_STAT register
1		TEMP_STAT = OR of all bits on THERM_STAT register
2		BUS_STAT = OR of all bits on BUS_STAT register
3		WAKE_UP = OR of all bits on WK_STAT register
4		HS_STAT = OR of all bits on HS_OL_OC_OT_STAT register
5		DEV_STAT = OR of all bits on DEV_STAT except CRC_STAT and SW_DEV
6		BD_STAT = OR of all bits on DSOV register
7		SPI_CRC_FAIL = (SPI_FAIL) OR (CRC_FAIL)

Serial Peripheral Interface



Figure 70 SPI Operation Mode

13.3.1 CRC

The SPI interface includes also 8 Bits (bits 24 to 31) used for Cyclic Redundancy Check (CRC) to ensure data integrity on sent or received SPI command.

The implemented CRC is based on Autosar specification of CRC Routines revision 4.3.0 and in particular the function CRC8-2FH.

The specification are based on the follow table:

Table 40 CRC8x2FH definition

CRC result width:	8 bits
Polynomial	2F _H
Initial Value	FF _H
Input data reflected	No
Result data reflected	No
XOR value	FF _H
Check	DF _H
Magic check	42 _H

Some examples of CRC calculation are shown in the follow table:

Table 41 CRC8x2FH calculation example

Data Bytes (hexadecimal)									CRC
00	00	00	00						12
F2	01	83							C2
0F	AA	00	55						C6
00	FF	55	11						77
33	22	55	AA	BB	CC	DD	EE	FF	11
92	6B	55							33
FF	FF	FF	FF						6C

Serial Peripheral Interface

Polynomial

The polynomial is:

$$x^8 + x^5 + x^3 + x^2 + x^1 + x^0 \tag{13.1}$$

Calculation in SDI and SDO

The calculation of the CRC is done considering the first 24 bits (BIT 0..23) either of SDI or SDO.

The content of SDO Payload (BIT 8..23) is referring the previous data written at the addressed register via SDI.

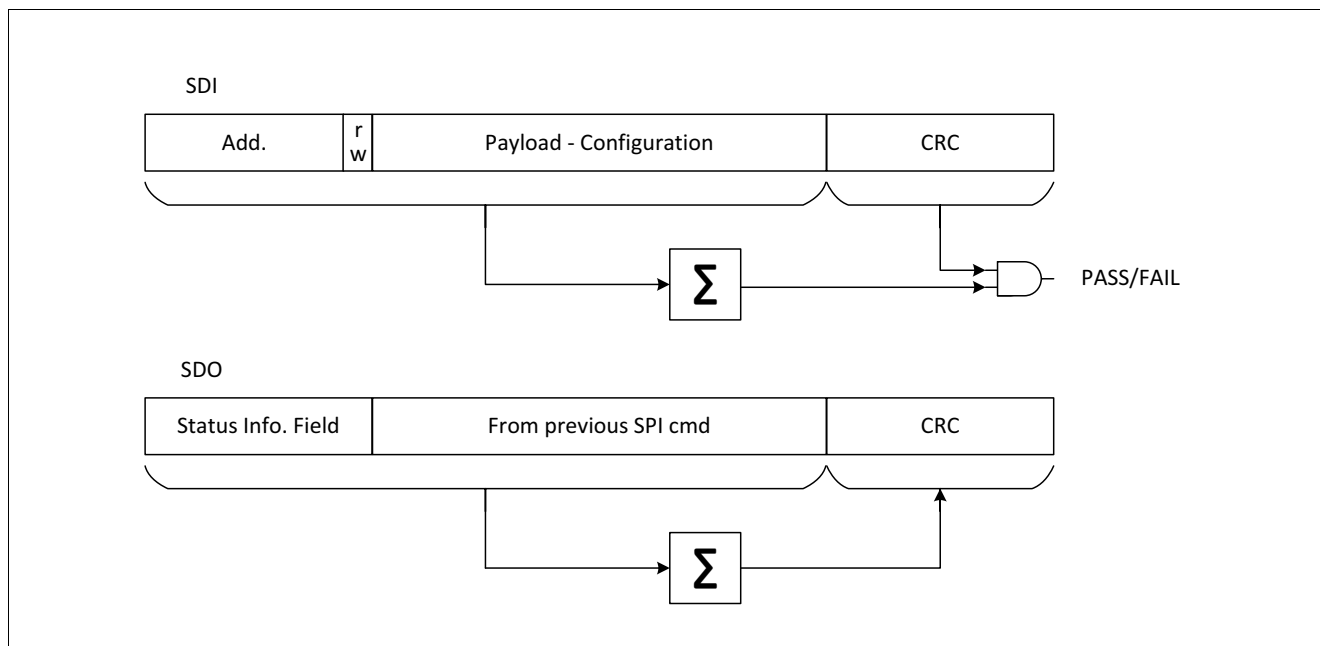

Figure 71 CRC calculation

CRC Activation and status information

For CRC activation, refer to [Chapter 5.2](#).

The CRC status ([CRC_STAT](#)) and failure ([CRC_FAIL](#)) are readable on [DEV_STAT](#).

Read out of the register which contains the [CRC_STAT](#) and [CRC_FAIL](#) is done ignoring the CRC field and no failure flag are set.

The [DEV_STAT](#) register shall be cleared considering the CRC setting (ON or OFF).

The [CRC_STAT](#) bit is read only.

The [CRC_FAIL](#) is set in the follow conditions:

- If the CRC is enabled and the μ C sends wrong CRC field.
- If the CRC is disabled and the μ C sends wrong static pattern (no A5_H).

CRC field in case of CRC disabled

In case that the CRC is not activated, the bits needed for CRC field have to be filled with static pattern.

In case of SDI, the CRC field has to be filled with A5_H (bits 24:31).

In case of SDO, the device will always answer with 5A_H (bits 24:31).

The status of the CRC is updated accordingly in [CRC_STAT](#) bit.

13.4 SPI Bit Mapping

The following figures show the mapping of the registers and the SPI bits of the respective registers.

The Control Registers are Read/Write Register with the following structure:

- Device Control Registers from 000 0001_B to 000 1011_B.
- Bridge Driver Control Registers from 001 0000_B to 001 1101_B.

Depending on bit 7 the bits are only read (setting bit 7 to '0') or also written (setting bit 7 to '1'). The new setting of the bit after a write can be seen with a new read / write command.

The Status Registers are Read/Clear with the following structure:

- Device Status Registers from 100 0000_B to 100 0110_B.
- Bridge Driver Status Registers from 101 0000_B to 101 1011_B.
- Product Family is 111 0000_B.

The registers can be read or can be cleared (if clearing is possible) depending on bit 7. To clear the payload of one of the Status Registers bit 7 must be set to 1.

The registers **WK_LVL_STAT**, and **FAM_PROD_STAT** are an exception as they show the actual voltage level at the respective WKx pin (LOW/HIGH), or a fixed family/ product ID respectively and can thus not be cleared.

It is recommended for proper diagnosis to clear respective status bits for wake events or failure.

When changing to a different device mode, certain configurations bits will be cleared automatically or modified:

- The device mode bits are updated to the actual status, e.g. when returning to Normal Mode.
- When changing to a low-power mode (Stop Mode or Sleep Mode), the diagnosis bits of the integrated module are not cleared.
- When changing to Stop Mode, the LIN control bits will not be modified.
- When changing to Sleep Mode, the LIN control bits will be modified if they were not OFF or wake capable before.

Note: The detailed behavior of the respective SPI bits and control functions is described in [Chapter 13.5](#), [Chapter 13.6](#) and in the respective module chapter. The bit type be marked as 'rwh' in case the device will modify respective control bits.

Serial Peripheral Interface

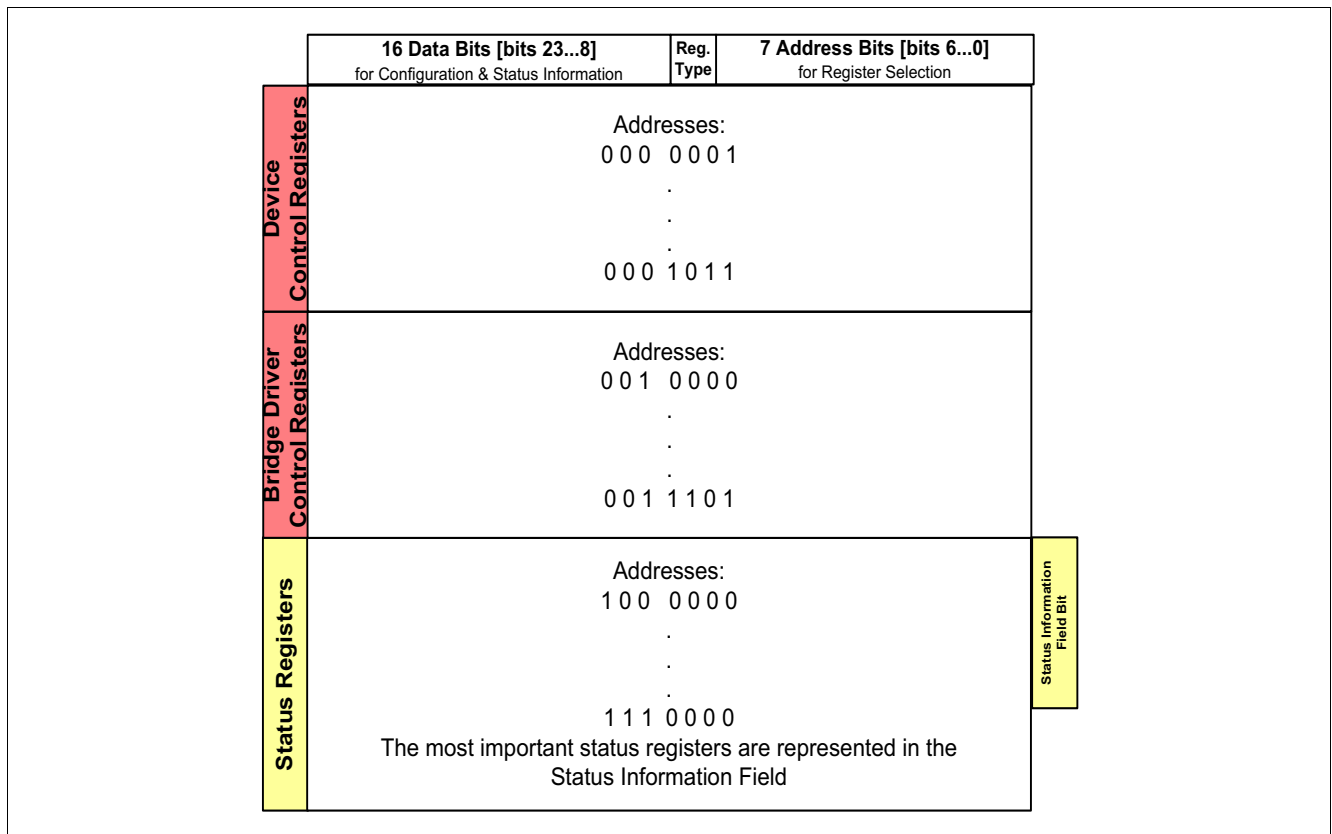

Figure 72 SPI Register Mapping Structure

The detailed register mappings for control registers and status registers are shown in [Table 42](#) and [Table 68](#) respectively.

13.4.1 Register Banking

In order to minimize the number of configuration registers, seven registers follow a bank structure.

The banked registers are:

- [WK_CTRL](#)
- [PWM_CTRL](#)
- [CCP_BLK](#)
- [TPRECHG](#)
- [HB_ICHG](#)
- [HB_PCHG_INIT](#)
- [TDON_HB_CTRL](#)
- [TDOFF_HB_CTRL](#)

In these register, the first 3 bits of the payload (bit 8 to 10) select the bank that has to be configured. The rest of the payload is used to configure the selected bank (for more details refer to the specific banked register).

In case that CRC is used, the CRC calculation is done considering the first 24 bits (from bit 0 to 23).

The banked registers can be read like the other configuration registers but in the SDO one '0' is automatically added after the status information field. [Figure 73](#) shows the structure of SDO in banked register.

Serial Peripheral Interface

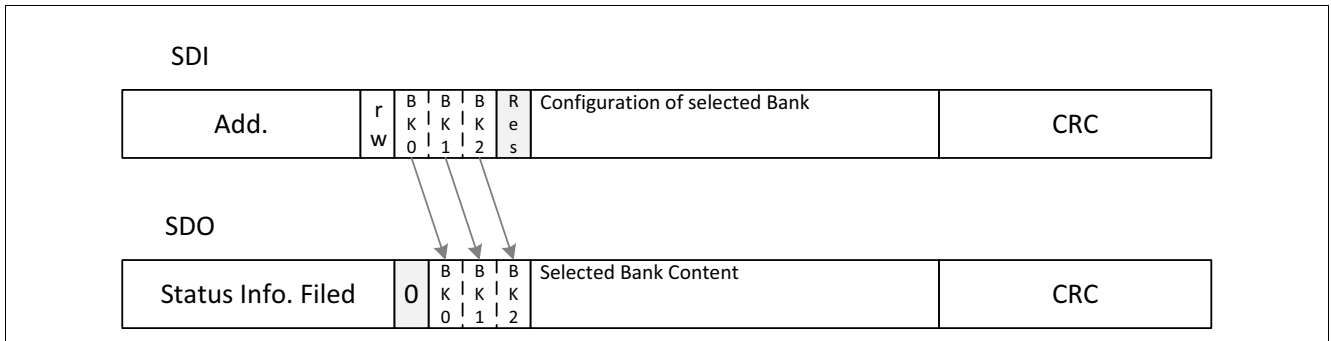

Figure 73 Register read Out of banked register (3 bit banking)

Serial Peripheral Interface

13.5 SPI control registers

READ/WRITE Operation (see also [Chapter 13.3](#)):

- The ‘POR / Soft Reset Value’ defines the register content after POR or device reset.
- The ‘Restart Value’ defines the register content after device restart, where ‘x’ means the bit is unchanged.
- There are different bit types:
 - ‘r’ = READ: read only bits (or reserved bits).
 - ‘rw’ = READ/WRITE: readable and writable bits.
 - ‘rwh’ = READ/WRITE/Hardware: readable/writable bits, which can also be modified by the device hardware.
- Reserved bits are marked as “Reserved” and always read as “0”. The respective bits shall also be programmed as “0”.
- Reading a register is done word wise by setting the SPI bit 7 to “0” (= Read Only).
- SPI control bits are in general not cleared or changed automatically. This must be done by the microcontroller via SPI programming. Exceptions to this behavior are stated at the respective register description and the respective bit type is marked with a ‘h’ meaning that the device is able to change the register content.

The registers are addressed wordwise.

Table 42 Register Overview

Register Short Name	Register Long Name	Offset Address	Page Number
SPI control registers, Device Control Registers			
M_S_CTRL	Mode and Supply Control	0000001 _B	155
HW_CTRL	Hardware Control	0000010 _B	157
WD_CTRL	Watchdog Control	0000011 _B	159
BUS_CTRL	and LIN Control	0000100 _B	161
WK_CTRL	Wake-up Control	0000101 _B	162
TIMER_CTRL	Timer 1 and Timer 2 Control and Selection	0000110 _B	164
SW_SD_CTRL	High-Side Switch Shutdown Control	0000111 _B	166
HS_CTRL	High-Side Switch Control	0001000 _B	168
INT_MASK	Interrupt Mask Control	0001001 _B	170
PWM_CTRL	PWM Configuration Control	0001010 _B	172
SYS_STAT_CTRL	System Status Control	0001011 _B	173
SPI control registers, Control registers bridge driver			
GENCTRL	General Bridge Control	0010000 _B	174
CSA	Current sense amplifier	0010001 _B	176
LS_VDS	Drain-Source monitoring threshold	0010010 _B	178
HS_VDS	Drain-Source monitoring threshold	0010011 _B	180
CCP_BLK	CCP and times selection	0010100 _B	182
HBMODE	Half-Bridge MODE	0010101 _B	183
TPRECHG	PWM pre-charge and pre-discharge time	0010110 _B	185

Serial Peripheral Interface

Table 42 Register Overview (cont'd)

Register Short Name	Register Long Name	Offset Address	Page Number
ST_ICHG	Static charge/discharge current	0010111 _B	186
HB_ICHG	PWM charge/discharge current	0011000 _B	187
HB_ICHG_MAX	PWM max. pre-charge/pre-discharge current and diagnostic pull-down	0011001 _B	188
HB_PCHG_INIT	PWM pre-charge/pre-discharge initialization	0011010 _B	190
TDON_HB_CTRL	PWM inputs TON configuration	0011011 _B	191
TDOFF_HB_CTRL	PWM inputs TOFF configuration	0011100 _B	192
BRAKE	Brake control	0011101 _B	193

Serial Peripheral Interface

13.5.1 Device Control Registers

Mode and Supply Control

M_S_CTRL

Mode and Supply Control

(000 0001_B)

Reset Value: see [Table 43](#)

15	14	13	12	11	10	9	8	7	6	5	4	3	2	1	0
MODE		RES			VCC1_OV_MOD		RES	RSTN_HYS	RES	I_PEAK_TH	RES			VCC1_RT	
rwh		r			rwh		r	rw	r	rw	r			rw	

Field	Bits	Type	Description
MODE	15:14	rwh	Device Mode Control 00 _B NORMAL , Normal Mode 01 _B SLEEP , Sleep Mode 10 _B STOP , Stop Mode 11 _B RESET , Device reset: Soft reset is executed (configuration of RSTN triggering in bit SOFT_RESET_RO)
RES	13:11	r	Reserved, always reads as 0
VCC1_OV_MOD	10:9	rwh	Reaction in case of VCC1 Over Voltage 00 _B NO , no reaction 01 _B INTN , INTN event is generated 10 _B RSTN , RSTN event is generated 11 _B FAILSAFE , Fail-Safe Mode is entered
RES	8	r	Reserved, always reads as 0
RSTN_HYS	7	rw	VCC1 Undervoltage Reset Hysteresis Selection (see also Chapter 12.7.1 for more information) 0 _B DEFAULT , default hysteresis applies as specified in the electrical characteristics table 1 _B HIGHEST , the highest rising threshold (VRT1,R) is always used for the release of the undervoltage reset
RES	6	r	Reserved, always reads as 0
I_PEAK_TH	5	rw	VCC1 Active Peak Threshold Selection 0 _B LOW , low VCC1 active peak threshold selected 1 _B HIGH , high VCC1 active peak threshold selected
RES	4:2	r	Reserved, always reads as 0
VCC1_RT	1:0	rw	VCC1 Reset Threshold Control 00 _B VRT1 , Vrt1 selected (highest threshold) 01 _B VRT2 , Vrt2 selected 10 _B VRT3 , Vrt3 selected 11 _B VRT4 , Vrt4 selected

Serial Peripheral Interface

Table 43 Reset of **M_S_CTRL**

Register Reset Type	Reset Values	Reset Short Name	Reset Mode	Note
POR/Soft reset	0000 0000 0000 0000 _B			
Restart	0000 0000 x0x0 00xx _B			

Notes

1. It is not possible to change from Stop Mode to Sleep Mode via SPI Command. See also the State Machine Chapter.
2. After entering Restart Mode, the MODE bits will be automatically set to Normal Mode.
3. The SPI output will always show the previously written state with a Write Command (what has been programmed before).

Serial Peripheral Interface

Hardware Control

HW_CTRL

Hardware Control

(000 0010_B)

Reset Value: see [Table 44](#)

15	14	13	12	11	10	9	8	7	6	5	4	3	2	1	0
RES		TSD2_DEL	VS_OV_SEL	SH_DISABLE	RSTN_DEL	RES		SOFT_RESET_RO	RES	RES		WD_STM_EN_1	RES		
r		rw	rw	rw	rw	r		rw	r	r		rwh	r		

Field	Bits	Type	Description
RES	15:13	r	Reserved, always reads as 0
TSD2_DEL	12	rw	TSD2 minimum Waiting Time Selection 0 _B 1s , Minimum waiting time until TSD2 is released again is always 1 s 1 _B 64s , Minimum waiting time until TSD2 is released again is 1 s, after >16 TSD2 consecutive events, it will extended x 64
VS_OV_SEL	11	rw	VS OV comparator threshold change 0 _B 20V , Default threshold setting ($V_{S,OVD1}$) 1 _B 30V , increased threshold setting ($V_{S,OVD2}$)
SH_DISABLE	10	rw	Sample and hold circuitry disable 0 _B ENABLED , Gate driver S&H circuitry enabled 1 _B DISABLED , Gate driver S&H circuitry disabled
RSTN_DEL	9	rw	Reset delay time 0 _B 10ms , Reset delay time 10 ms (t_{RD1}) 1 _B 2ms , Reset delay time to 2 ms (t_{RD2})
RES	8:7	r	Reserved, always reads as 0
SOFT_RESET_RO	6	rw	Soft Reset Configuration 0 _B RSTN , RSTN will be triggered (pulled low) during a Soft Reset 1 _B NO_RSTN , no RSTN trigger during a Soft Reset
RES	5	r	Reserved, always reads as 0
RES	4:3	r	Reserved, always reads as 0
WD_STM_EN_1	2	rwh	Watchdog Deactivation during Stop Mode, bit1 0 _B ACTIVE , Watchdog is active in Stop Mode 1 _B INACTIVE , Watchdog is deactivated in Stop Mode
RES	1:0	r	Reserved, always reads as 0

Table 44 Reset of **HW_CTRL**

Register Reset Type	Reset Values	Reset Short Name	Reset Mode	Note
POR	0000 0000 0000 0000 _B			
Soft reset	0000 00x0 0000 0000 _B			
Restart	000x 00x0 0x00 0000 _B			

Notes

1. *WD_STM_EN_1 will also be cleared when changing from Stop Mode to Normal Mode .*

Serial Peripheral Interface

Watchdog Control

WD_CTRL

Watchdog Control

(000 0011_B)

Reset Value: see [Table 45](#)

15	14	13	12	11	10	9	8	7	6	5	4	3	2	1	0
CHEC KSUM		RES						WD_S TM_E N_0	WD_C FG	WD_E N_WK _BUS	RES	WD_TIMER			
rw		r						rwh	rw	rwh	r	rwh			

Field	Bits	Type	Description
CHECKSUM	15	rw	Watchdog Setting Check Sum Bit 0 _B 0, Counts as 0 for checksum calculation 1 _B 1, Counts as 1 for checksum calculation
RES	14:7	r	Reserved, always reads as 0
WD_STM_EN_0	6	rwh	Watchdog Deactivation during Stop Mode, bit0 0 _B ACTIVE , Watchdog is active in Stop Mode 1 _B INACTIVE , Watchdog is deactivated in Stop Mode
WD_CFG	5	rw	Watchdog Configuration 0 _B TIMEOUT , Watchdog works as a Time-Out watchdog 1 _B WINDOW , Watchdog works as a Window watchdog
WD_EN_WK_BUS	4	rwh	Watchdog Enable after Bus Wake in Stop Mode 0 _B DISABLED , Watchdog will not start after a or LIN wake-up event 1 _B ENABLED , Watchdog starts with a long open window after or LIN Wake-up event
RES	3	r	Reserved, always reads as 0
WD_TIMER	2:0	rwh	Watchdog Timer Period 000 _B 10ms , 10ms 001 _B 20ms , 20ms 010 _B 50ms , 50ms 011 _B 100ms , 100ms 100 _B 200ms , 200ms 101 _B 500ms , 500ms 110 _B 1s , 1s 111 _B 10s , 10s

Table 45 Reset of [WD_CTRL](#)

Register Reset Type	Reset Values	Reset Short Name	Reset Mode	Note
POR/Soft reset	0000 0000 0001 0100 _B			
Restart	0000 0000 000x 0100 _B			

Notes

1. See also [Chapter 12.2.4](#) for more information on disabling the watchdog in Stop Mode.
2. See chapter [Chapter 12.2.5](#) for more information on the effect of the bit `WD_EN_WK_BUS`.
3. See chapter [Chapter 12.2.3](#) for calculation of checksum.

Serial Peripheral Interface

and LIN Control

BUS_CTRL

and LIN Control

(000 0100_B)

Reset Value: see [Table 46](#)

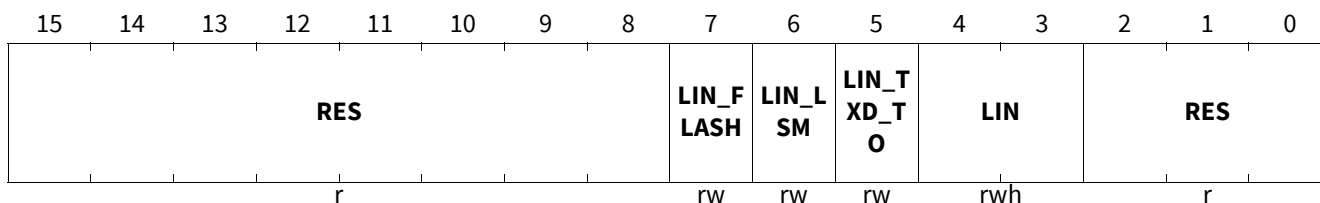

Field	Bits	Type	Description
RES	15:8	r	Reserved, always reads as 0
LIN_FLASH	7	rw	LIN Flash 0 _B ACTIVE , Slope control mechanism active 1 _B INACTIVE , Deactivation of slope control for baudrates up to 115 kBaud
LIN_LSM	6	rw	LIN LSM 0 _B NORMAL , LIN Normal Mode is activated 1 _B LOW_SLOPE , LIN Low-Slope Mode (10.4 kBaud) activated
LIN_TXD_TO	5	rw	LIN TXD TO 0 _B DISABLED , TXD Time-out feature disabled 1 _B ENABLED , TXD Time-out feature enabled
LIN	4:3	rwh	LIN Module Modes 00 _B OFF , LIN OFF 01 _B WAKE , LIN wake capable 10 _B RECEIVE , LIN Receive Only Mode 11 _B NORMAL , LIN Normal Mode
RES	2:0	r	Reserved, always reads as 0

Table 46 Reset of **BUS_CTRL**

Register Reset Type	Reset Values	Reset Short Name	Reset Mode	Note
POR/Soft reset	0000 0000 0000 0000 _B			
Restart	0000 0000 xx0y 0000 _B			

Notes

1. The reset values for LIN transceivers are marked with 'y' because they will vary depending on the cause of change.
2. See, [Figure 25](#) for detailed state changes of LIN transceivers for different device modes.
3. Failure Handling Mechanism: When the device enters Fail-Safe Mode due to a failure, then **BUS_CTRL** is modified by the device to 0000 0000 xxx0 1001_B to ensure that the device can be woken again. See also the description in [Chapter 8.1](#) and [Chapter 9.2.1](#) for **WK_CTRL** for other wake sources when entering Fail-Safe Mode.
4. When in Software Development Mode the POR/Soft Reset value are: LIN=11_B.

Serial Peripheral Interface

Wake-up Control

WK_CTRL

Wake-up Control

(000 0101_B)

Reset Value: see [Table 47](#)

15	14	13	12	11	10	9	8	7	6	5	4	3	2	1	0
RES	RES	WK_FILT		WK_PUPD		RES	WK_EN		RES	WK_BNK					
r	r	rw		rw		r	rw		r	rw					

Field	Bits	Type	Description
RES	15	r	Reserved, always reads as 0
RES	14	r	Reserved, always reads as 0
WK_FILT	13:11	rw	Wake-up Filter Time Configuration 000 _B 16us , Filter with 16 μs filter time (static sensing) 001 _B 64us , Filter with 64 μs filter time (static sensing) 010 _B TIMER1 , Filtering at the end of the on-time; filter time of 16 μs (cyclic sensing) is selected, Timer1 011 _B TIMER2 , Filtering at the end of the on-time; filter time of 16 μs (cyclic sensing) is selected, Timer2 100 _B SYNC , Filter at the end of settle time (80 μs), filter time of 16 μs (cyclic sensing) is selected, SYNC ¹⁾²⁾ 101 _B , reserved 110 _B , reserved 111 _B , reserved
WK_PUPD	10:9	rw	WKx Pull-Up/Pull-Down Configuration 00 _B NO , No pull-up/pull-down selected 01 _B PULL_DOWN , Pull-down resistor selected 10 _B PULL_UP , Pull-up resistor selected 11 _B AUTO , Automatic switching to pull-up or pull-down
RES	8:7	r	Reserved, always reads as 0
WK_EN	6:5	rw	WKx Enable 00 _B WK_OFF , WKx module OFF 01 _B WK_ON , WKx module ON 10 _B SYNC , OFF or (in case of WK4), it is configured as SYNC input 11 _B OFF , OFF
RES	4:3	r	Reserved, always reads as 0
WK_BNK	2:0	rw	WKs input Banking 011 _B WK4 , WK4 Module (Bank 4) 101 _B , reserved 110 _B , reserved 111 _B , reserved

1) This setting is available only in case of WK4 configured as WK_EN=10_B.

2) The min TON time for cyclic sense with SYNC is 100 μs.

Serial Peripheral Interface

Table 47 Reset of **WK_CTRL**

Register Reset Type	Reset Values	Reset Short Name	Reset Mode	Note
POR/Soft reset	0000 0000 0010 0000 _B			
Restart	00xx xxx0 0xx0 0000 _B			

Notes

1. The SYNC functionality is accessible only if the Bank 4 is selected.
2. When selecting a filter time configuration, the user must make sure to also assign the respective timer/SYNC to at least one HS switch during cyclic sense operation.
3. At Fail-Safe Mode entry **WK_EN** will be automatically changed (by the device) in "01". WK4 if configured as SYNC previously
4. During Fail-Safe Mode the **WK_FILT** bits are ignored and static-sense with 16 μs filter time is used by default.

Serial Peripheral Interface

Timer 1 and Timer2 Control and Selection

TIMER_CTRL

Timer 1 and Timer2 Control and Selection (000 0110_B)

Reset Value: see [Table 48](#)

15	14	13	12	11	10	9	8	7	6	5	4	3	2	1	0
TIMER2_ON			RES	TIMER2_PER			CYCWK	TIMER1_ON			RES	TIMER1_PER			
rwh			r	rwh			rwh	rwh			r	rwh			

Field	Bits	Type	Description
TIMER2_ON	15:13	rwh	Timer2 On-Time Configuration 000 _B OFF_LOW , OFF / Low (timer not running, HSx output is low) 001 _B 100us , 0.1ms on-time 010 _B 300us , 0.3ms on-time 011 _B 1ms , 1.0ms on-time 100 _B 10ms , 10ms on-time 101 _B 20ms , 20ms on-time 110 _B OFF_HIGH , OFF / HIGH (timer not running, HSx output is high) 111 _B , reserved, same behaviour as 110 _B
RES	12	r	Reserved, always reads as 0
TIMER2_PER	11:9	rwh	Timer2 Period Configuration 000 _B 10ms , 10ms 001 _B 20ms , 20ms 010 _B 50ms , 50ms 011 _B 100ms , 100ms 100 _B 200ms , 200ms 101 _B 500ms , 500ms 110 _B 1s , 1s 111 _B 2s , 2s
CYCWK	8:7	rwh	Cyclic Wake Configuration 00 _B DISABLED , Timer1 and Timer2 disabled as wake-up sources 01 _B TIMER1 , Timer1 is enabled as wake-up source (Cyclic Wake) 10 _B TIMER2 , Timer2 is enabled as wake-up source (Cyclic Wake) 11 _B , reserved

Serial Peripheral Interface

Field	Bits	Type	Description
TIMER1_ON	6:4	rwh	Timer1 On-Time Configuration 000 _B OFF_LOW , OFF / Low (timer not running, HSx output is low) 001 _B 100us , 0.1ms on-time 010 _B 300us , 0.3ms on-time 011 _B 1ms , 1.0ms on-time 100 _B 10ms , 10ms on-time 101 _B 20ms , 20ms on-time 110 _B OFF_HIGH , OFF / HIGH (timer not running, HSx output is high) 111 _B , reserved, same behaviour as 110 _B
RES	3	r	Reserved, always reads as 0
TIMER1_PER	2:0	rwh	Timer1 Period Configuration 000 _B 10ms , 10ms 001 _B 20ms , 20ms 010 _B 50ms , 50ms 011 _B 100ms , 100ms 100 _B 200ms , 200ms 101 _B 500ms , 500ms 110 _B 1s , 1s 111 _B 2s , 2s

Table 48 Reset of **TIMER_CTRL**

Register Reset Type	Reset Values	Reset Short Name	Reset Mode	Note
POR/Soft reset	0000 0000 0000 0000 _B			
Restart	0000 0000 0000 0000 _B			

Notes

1. The timer must be first assigned and is then automatically activated as soon as the on-time is configured.
2. If cyclic sense is selected and the HSx switch is cleared during Restart Mode then also the timer settings (period and on-time) are cleared to avoid incorrect switch detection. However, the timer settings are not cleared in case of failure not leading to Restart Mode.
3. In case the timer is set as wake sources and cyclic sense is running, then both cyclic sense and cyclic wake will be active at the same time.
4. Timer accuracy is linked to the oscillator accuracy (see Parameter P_13.12.43).

Serial Peripheral Interface

High-Side Switch Shutdown Control

SW_SD_CTRL

High-Side Switch Shutdown Control

(000 0111_B)

Reset Value: see [Table 49](#)

15	14	13	12	11	10	9	8	7	6	5	4	3	2	1	0
RES	HS3_OV_REC	HS2_OV_REC	HS1_OV_REC	HS_OT_SD_DIS	RES	HS3_OV_SDN_DIS	HS2_OV_SDN_DIS	HS1_OV_SDN_DIS	HS_OV_SDN_DIS	HS_UV_SD_DIS	RES	HS_UV_REC			
r	rw	rw	rw	rw	r	rw	rw	rw	rw	rw	r	rw			r

Field	Bits	Type	Description
RES	15	r	Reserved, always reads as 0
HS3_OV_REC	14	rw	Switch recovery after removal of VS Overvoltage for HS3 0 _B DISABLED , Switch recovery is disabled 1 _B PREVIOUS , Previous state before VS Overvoltage is enabled after Overvoltage condition is removed
HS2_OV_REC	13	rw	Switch recovery after removal of VS Overvoltage for HS2 0 _B DISABLED , Switch recovery is disabled 1 _B PREVIOUS , Previous state before VS Overvoltage is enabled after Overvoltage condition is removed
HS1_OV_REC	12	rw	Switch recovery after removal of VS Overvoltage for HS1 0 _B DISABLED , Switch recovery is disabled 1 _B PREVIOUS , Previous state before VS Overvoltage is enabled after Overvoltage condition is removed
HS_OT_SD_DIS	11	rw	Shutdown Disabling of all HS in case of Overtemperature event 0 _B ALL , shutdown for all HSx in case of Overtemperature 1 _B INDIVIDUAL , individual shutdown in case of Overtemperature
RES	10	r	Reserved, always reads as 0
HS3_OV_SDN_DIS	9	rw	Shutdown Disabling of HS3 in case of input supply overvoltage in Normal Mode 0 _B ENABLED , shutdown enabled in case of VS Overvoltage 1 _B DISABLED , shutdown disabled in case of VS Overvoltage

Serial Peripheral Interface

Field	Bits	Type	Description
HS2_OV_SDN_DIS	8	rw	Shutdown Disabling of HS2 in case of input supply overvoltage in Normal Mode 0 _B ENABLED , shutdown enabled in case of VS Overvoltage 1 _B DIASBLED , shutdown disabled in case of VS Overvoltage
HS1_OV_SDN_DIS	7	rw	Shutdown Disabling of HS1 in case of input supply overvoltage in Normal Mode 0 _B ENABLED , shutdown enabled in case of VS Overvoltage 1 _B DISABLED , shutdown disabled in case of VS Overvoltage
HS_OV_SDS_DIS	6	rw	Shutdown Disabling of HSx in case of input supply overvoltage in Stop Mode or Sleep Mode 0 _B ENABLED , shutdown enabled in case of VS Overvoltage 1 _B DISABLED , shutdown disabled in case of VS Overvoltage
HS_UV_SD_DIS	5	rw	Shutdown Disabling of HSx in case of input supply undervoltage 0 _B ENABLED , shutdown enabled in case of VS Undervoltage 1 _B DISABLED , shutdown disabled in case of VS Undervoltage
RES	4	r	Reserved, always reads as 0
HS_UV_REC	3	rw	Switch recovery after removal of Undervoltage for HSx 0 _B DISABLED , Switch recovery is disabled 1 _B PREVIOUS , Previous state before VS Undervoltage is enabled after Undervoltage condistion is removed
RES	2:0	r	Reserved, always reads as 0

Table 49 Reset of SW_SD_CTRL

Register Reset Type	Reset Values	Reset Short Name	Reset Mode	Note
POR/Soft reset	0000 0000 0000 0000 _B			
Restart	0xxx x0xx xxx0 x000 _B			

Serial Peripheral Interface

High-Side Switch Control

HS_CTRL

High-Side Switch Control

(000 1000_B)

Reset Value: see [Table 50](#)

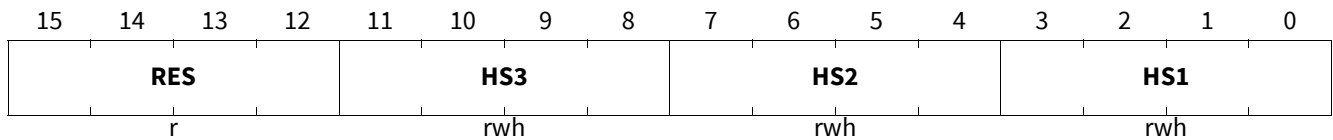

Field	Bits	Type	Description
RES	15:12	r	Reserved, always reads as 0
HS3	11:8	rwh	HS3 Configuration 0000 _B OFF , OFF 0001 _B ON , ON 0010 _B TIMER1 , Controlled by Timer1 0011 _B TIMER2 , Controlled by Timer2 0100 _B PWM1 , Controlled by PWM1 0101 _B PWM2 , Controlled by PWM2 0110 _B PWM3 , Controlled by PWM3 0111 _B PWM4 , Controlled by PWM4 1000 _B WK4_SYNC , Synchronized with WK4/SYNC 1001 _B , reserved 1010 _B , reserved 1011 _B , reserved 1100 _B , reserved 1101 _B , reserved 1110 _B , reserved 1111 _B , reserved
HS2	7:4	rwh	HS2 Configuration 0000 _B OFF , OFF 0001 _B ON , ON 0010 _B TIMER1 , Controlled by Timer1 0011 _B TIMER2 , Controlled by Timer2 0100 _B PWM1 , Controlled by PWM1 0101 _B PWM2 , Controlled by PWM2 0110 _B PWM3 , Controlled by PWM3 0111 _B PWM4 , Controlled by PWM4 1000 _B WK4_SYNC , Synchronized with WK4/SYNC 1001 _B , reserved 1010 _B , reserved 1011 _B , reserved 1100 _B , reserved 1101 _B , reserved 1110 _B , reserved 1111 _B , reserved

Serial Peripheral Interface

Field	Bits	Type	Description
HS1	3:0	rwh	HS1 Configuration 0000 _B OFF , OFF 0001 _B ON , ON 0010 _B TIMER1 , Controlled by Timer1 0011 _B TIMER2 , Controlled by Timer2 0100 _B PWM1 , Controlled by PWM1 0101 _B PWM2 , Controlled by PWM2 0110 _B PWM3 , Controlled by PWM3 0111 _B PWM4 , Controlled by PWM4 1000 _B WK4_SYNC , Synchronized with WK4/SYNC 1001 _B , reserved 1010 _B , reserved 1011 _B , reserved 1100 _B , reserved 1101 _B , reserved 1110 _B , reserved 1111 _B , reserved

Table 50 Reset of **HS_CTRL**

Register Reset Type	Reset Values	Reset Short Name	Reset Mode	Note
POR/Soft reset	0000 0000 0000 0000 _B			
Restart	0000 0000 0000 0000 _B			

PWMx in this register designates the internal PWM generators for the integrated high-side switches.

Serial Peripheral Interface

Interrupt Mask Control¹⁾

INT_MASK

Interrupt Mask Control

(000 1001_B)

Reset Value: see [Table 51](#)

15	14	13	12	11	10	9	8	7	6	5	4	3	2	1	0
RES							INTN_CYC_EN	WD_SDM_DISABLE	WD_SDM	SPI_CRC_FAIL	BD_STAT	HS_STAT	BUS_STAT	TEMP_STAT	SUPPLY_STAT
r							rw	rw	rw	rw	rw	rw	rw	rw	rw

Field	Bits	Type	Description
RES	15:9	r	Reserved, always reads as 0
INTN_CYC_EN	8	rw	Periodical INTN generation 0 _B DISABLED , no periodical INTN event generated in case of pending interrupts 1 _B ENABLED , periodical INTN event generated in case of pending interrupts
WD_SDM_DISABLE	7	rw	Disable Watchdog in Software Development Mode 0 _B ENABLED , WD is enabled in Software Development Mode 1 _B DISABLED , WD is disabled in Software Development Mode
WD_SDM	6	rw	Watchdog failure in Software Development Mode 0 _B DISABLED , no INTN event generated in case of WD trigger failure in Software Development Mode 1 _B ENABLED , one INTN event is generated in case of WD trigger failure in Software Development Mode
SPI_CRC_FAIL	5	rw	SPI and CRC interrupt generation 0 _B DISABLED , no INTN event generated in case of SPI_FAIL or CRC_FAIL 1 _B ENABLED , one INTN event is generated in case of SPI_FAIL or CRC_FAIL
BD_STAT	4	rw	Bridge Driver Interrupt generation 0 _B DISABLED , no INTN event generated in case BD_STAT (on Status Information Field) is set 1 _B ENABLED , one INTN event generated in case BD_STAT (on Status Information Field) is set
HS_STAT	3	rw	High Side Interrupt generation 0 _B DISABLED , no INTN event generated in case HS_STAT (on Status Information Field) is set 1 _B ENABLED , one INTN event generated in case HS_STAT (on Status Information Field) is set

1) Every event will generate a signal on the INTN pin (when masked accordingly).
Even if the status-bit was already set in the corresponding status-register it can still trigger a signal on the INTN pin.

Serial Peripheral Interface

Field	Bits	Type	Description
BUS_STAT	2	rw	BUS Interrupt generation 0_B DISABLED , no INTN event generated in case BUS_STAT (on Status Information Field) is set 1_B ENABLED , one INTN event generated in case BUS_STAT (on Status Information Field) is set
TEMP_STAT	1	rw	Temperature Interrupt generation 0_B DISABLED , no INTN event generated in case TEMP_STAT (on Status Information Field) is set 1_B ENABLED , one INTN event generated in case TEMP_STAT (on Status Information Field) is set
SUPPLY_STAT	0	rw	SUPPLY Status Interrupt generation 0_B DISABLED , no INTN event generated in case SUPPLY_STAT (on Status Information Field) is set 1_B ENABLED , one INTN event generated in case SUPPLY_STAT (on Status Information Field) is set

Table 51 Reset of **INT_MASK**

Register Reset Type	Reset Values	Reset Short Name	Reset Mode	Note
POR/Soft reset	0000 0001 0100 0000 _B			
Restart	0000 000x xxxx xxxx _B			

Serial Peripheral Interface

PWM Configuration Control

PWM_CTRL

PWM Configuration Control

(000 1010_B)

Reset Value: see Table 52

15	14	13	12	11	10	9	8	7	6	5	4	3	2	1	0
RES	PWM_FREQ	PWM_DC										RES	PWM_BNK		
r	rw	rw										r	rw		

Field	Bits	Type	Description
RES	15	r	Reserved, always reads as 0
PWM_FREQ	14	rw	PWM generator Frequency Setting 0 _B 100Hz, 100Hz is selected 1 _B 200Hz, 200Hz is selected
PWM_DC	13:4	rw	PWM Duty Cycle Setting (bit4 = LSB; bit13 = MSB) 00 0000 0000 _B , 100% OFF, i.e. HS = OFF xx xxxx xxxx _B , ON with duty cycle fraction of 1024 11 1111 1111 _B , 100% ON, i.e. HS = ON
RES	3	r	Reserved, always reads as 0
PWM_BNK	2:0	rw	Internal PWM generator selection 000 _B PWM1, PWM1 Module 001 _B PWM2, PWM2 Module 010 _B PWM3, PWM3 Module 011 _B PWM4, PWM4 Module 1xx _B , Don't care

Table 52 Reset of PWM_CTRL

Register Reset Type	Reset Values	Reset Short Name	Reset Mode	Note
POR/Soft reset	0000 0000 0000 0000 _B			
Restart	0xxx xxxx xxxx 0000 _B			

PWMx in this register designates the internal PWM generators for the integrated high-side switches.

Notes

- 0% and 100% duty cycle settings are used to have the switch turned ON or OFF respectively.
- The desired duty cycle should be set first before the HSx is enabled as PWM.
- The PWM signal is correct only after at least one PWM pulse.
- PWM generator accuracy is linked to the oscillator accuracy (see parameter P_13.12.43).

Serial Peripheral Interface

System Status Control

SYS_STAT_CTRL

System Status Control

(000 1011_B)

Reset Value: see [Table 53](#)

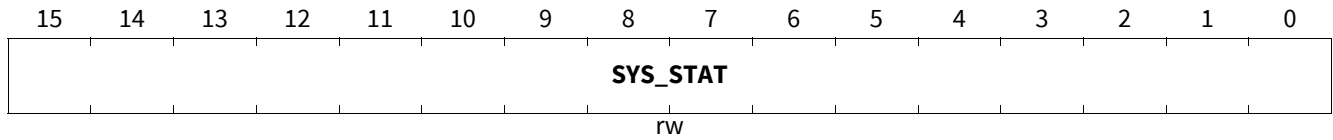

Field	Bits	Type	Description
SYS_STAT	15:0	rw	System Status Control (bit0=LSB; bit15=MSB) Dedicated bytes for system configuration, access only by microcontroller. Cleared after power up and soft reset.

Table 53 Reset of **SYS_STAT_CTRL**

Register Reset Type	Reset Values	Reset Short Name	Reset Mode	Note
POR / Soft reset	0000 0000 0000 0000 _B			
Restart	XXXX XXXX XXXX XXXX _B			

Note: This register is intended for storing system configuration of the ECU by the microcontroller and is only accessible in Normal Mode. The register is not accessible by the TLE9564QX and is also not cleared after Fail-Safe or Restart Mode. It allows the microcontroller to quickly store system configuration without losing data.

Serial Peripheral Interface

13.5.2 Control registers bridge driver

General Bridge Control

GENCTRL

General Bridge Control

(001 0000_B)

Reset Value: see [Table 54](#)

15	14	13	12	11	10	9	8	7	6	5	4	3	2	1	0
BDFR EQ	RES	RES	CPUV TH	FET_L VL	CPST GA	BDOV _REC	IPCHG ADT	AGC	CPEN	POCH GDIS	AGCFI LT	EN_GE N_CH ECK	IHOLD	FMOD E	
rw	r	r	rw	rw	rw	rw	rw	rw	rw	rw	rw	rw	rw	rw	

Field	Bits	Type	Description
BDFREQ	15	rw	Bridge driver synchronization frequency 0 _B 18MHz , typ. 18.75 MHz (default) 1 _B 37MHz , typ. 37.5 MHz
RES	14	r	Reserved, always reads as 0
RES	13	r	Reserved, always reads as 0
CPUVTH	12	rw	Charge pump under voltage (referred to VS) 0 _B TH1 , (default) CPUV threshold 1 for FET_LVL = 0, CPUV threshold 1 for FET_LVL = 1 1 _B TH2 , CPUV threshold 2 for FET_LVL = 0, CPUV threshold 2 for FET_LVL = 1
FET_LVL	11	rw	External MOSFET normal / logic level selection 0 _B LOGIC , Logic level MOSFET selected 1 _B NORMAL , Normal level MOSFET selected(default)
CPSTGA	10	rw	Automatic switchover between dual and single charge pump stage 0 _B INACTIVE , Automatic switch over deactivated (default) 1 _B ACTIVE , Automatic switch over activated
BDOV_REC	9	rw	Bridge driver recover from VS and VSINT Overvoltage 0 _B INACTIVE , Recover deactivated (default) 1 _B ACTIVE , Recover activated
IPCHGADT	8	rw	Adaptation of the pre-charge and pre-discharge current 0 _B 1STEP , 1 current step (default) 1 _B 2STEPS , 2 current steps

Serial Peripheral Interface

Field	Bits	Type	Description
AGC	7:6	rw	Adaptive gate control 00 _B INACTIVE1 , (default) Adaptive gate control disabled, pre-charge and pre-discharge disabled 01 _B INACTIVE2 , Adaptive gate control disabled, precharge is enabled with IPRECHG = IPCHGINIT, pre-discharge is enabled with IPREDCHG = IPDCHGINIT 10 _B ACTIVE , Adaptive gate control enabled, IPRECHG and IPREDCHG are self adapted 11 _B , reserved. Adaptive gate control enabled, IPRECHG and IPREDCHG are self adapted
CPEN	5	rw	CPEN 0 _B DISABLED , Charge pump disabled (default) 1 _B ENABLED , Charge pump enabled
POCHGDIS	4	rw	Postcharge disable bit 0 _B ENABLED , The postcharge phase is enabled during PWM (default) 1 _B DISABLED , The postcharge phase is disabled during PWM
AGCFILT	3	rw	Filter for adaptive gate control 0 _B NO_FILT , No filter applied (default) 1 _B FILT_APPL , Filter applied
EN_GEN_CHECK	2	rw	Detection of active / FW MOSFET 0 _B DISABLED , Detection disabled (default) 1 _B ENABLED , Detection enabled
IHOLD	1	rw	Gate driver hold current IHOLD 0 _B TH1 , (default) Charge: I_{CHG15} , discharge I_{DCHG15} 1 _B TH2 , Charge: I_{CHG20} , discharge: I_{DCHG20}
FMODE	0	rw	Frequency modulation of the charge pump 0 _B NO , No modulation 1 _B 15KHz , Modulation frequency 15.6 kHz (default)

Table 54 Reset of GENCTRL

Register Reset Type	Reset Values	Reset Short Name	Reset Mode	Note
POR/Soft reset	0000 1000 0000 0001 _B			
Restart	x00x xxxx xxxx xxxx _B			

Serial Peripheral Interface

Current sense amplifier

CSA

Current sense amplifier

(001 0001_B)

Reset Value: see [Table 55](#)

15	14	13	12	11	10	9	8	7	6	5	4	3	2	1	0
RES					PWM_NB	CSO_CAP	CSD	OCFILT		CSA_OFF	OCTH	CSAG		OCEN	
r					rw	rw	rw	rw		rw	rw	rw		rw	

Field	Bits	Type	Description
RES	15:11	r	Reserved, always reads as 0
PWM_NB	10	rw	Selection of 3 or 6 PWM inputs 0 _B 3PWM , 3 PWM inputs (default) 1 _B 6PWM , 6 PWM inputs
CSO_CAP	9	rw	Capacitance connected to the current sense amplifier output (CCSO), see also Chapter 12.11.4 0 _B 400pF , CCSO < 400 pF (default) 1 _B 2nF , 400 pF < CCSO < 2.2 nF
CSD	8	rw	Direction of the current sense amplifier 0 _B UNI , Unidirectional 1 _B BI , Bidirectional (default)
OCFILT	7:6	rw	Overcurrent filter time of CSO 00 _B 6us , 6 μs (default) 01 _B 10us , 10 μs 10 _B 50us , 50 μs 11 _B 100us , 100 μs
CSA_OFF	5	rw	CSA OFF 0 _B CSA_ON , CSA enabled 1 _B CSA_OFF , CSA disabled (default)
OCTH	4:3	rw	Overcurrent detection threshold of CSO 00 _B TH1 , $V_{CSO} > V_{CC1}/2 + 2 \times V_{CC1}/20$ or $V_{CSOx} < V_{CC1}/2 - 2 \times V_{CC1}/20$ (default) 01 _B TH2 , $V_{CSO} > V_{CC1}/2 + 4 \times V_{CC1}/20$ or $V_{CSOx} < V_{CC1}/2 - 4 \times V_{CC1}/20$ 10 _B TH3 , $V_{CSO} > V_{CC1}/2 + 5 \times V_{CC1}/20$ or $V_{CSOx} < V_{CC1}/2 - 5 \times V_{CC1}/20$ 11 _B TH4 , $V_{CSO} > V_{CC1}/2 + 6 \times V_{CC1}/20$ or $V_{CSOx} < V_{CC1}/2 - 6 \times V_{CC1}/20$
CSAG	2:1	rw	Gain of the current sense amplifier 00 _B 10VV , G_{DIFF10} (default) 01 _B 20VV , G_{DIFF20} 10 _B 40VV , G_{DIFF40} 11 _B 60VV , G_{DIFF60}
OCEN	0	rw	Overcurrent shutdown Enable 0 _B DISABLED , Disabled 1 _B ENABLED , Enabled (default)

Serial Peripheral Interface

Table 55 Reset of **CSA**

Register Reset Type	Reset Values	Reset Short Name	Reset Mode	Note
POR/Soft reset	0000 0001 0010 0001 _B			
Restart	0000 0xxx xxxx xxx1 _B			

Serial Peripheral Interface

Drain-Source monitoring threshold LS1-3

LS_VDS

VDS monitoring threshold LS1-3

(001 0010_B)

Reset Value: see [Table 56](#)

15	14	13	12	11	10	9	8	7	6	5	4	3	2	1	0
RES		TFVDS		RES			LS3VDSTH		LS2VDSTH			LS1VDSTH			
r		rw		r			rw		rw			rw			

Field	Bits	Type	Description
RES	15:14	r	Reserved. Always read as 0
TFVDS	13:12	rw	Filter time of drain-source voltage monitoring 00 _B 500ns , 0.5 μs (default) 01 _B 1us , 1 μs 10 _B 2us , 2 μs 11 _B 6us , 6 μs
RES	11:9	r	Reserved, always reads as 0
LS3VDSTH	8:6	rw	LS3 drain-source overvoltage threshold 000 _B 160mV , 0.16 V 001 _B 200mV , 0.20 V (default) 010 _B 300mV , 0.30 V 011 _B 400mV , 0.40 V 100 _B 500mV , 0.50 V 101 _B 600mV , 0.60 V 110 _B 800mV , 0.80 V 111 _B 2V , 2.0 V
LS2VDSTH	5:3	rw	LS2 drain-source overvoltage threshold 000 _B 160mV , 0.16V 001 _B 200mV , 0.20 V (default) 010 _B 300mV , 0.30 V 011 _B 400mV , 0.40 V 100 _B 500mV , 0.50 V 101 _B 600mV , 0.60 V 110 _B 800mV , 0.80 V 111 _B 2V , 2.0 V
LS1VDSTH	2:0	rw	LS1 drain-source overvoltage threshold 000 _B 160mV , 0.16 V 001 _B 200mV , 0.20 V (default) 010 _B 300mV , 0.30 V 011 _B 400mV , 0.40 V 100 _B 500mV , 0.50 V 101 _B 600mV , 0.60 V 110 _B 800mV , 0.80 V 111 _B 2V , 2.0 V

Serial Peripheral Interface

Table 56 Reset of LS_VDS

Register Reset Type	Reset Values	Reset Short Name	Reset Mode	Note
POR/Soft reset	0000 0000 0100 1001 _B	0000 0000 0000 0000		
Restart	0000 000x xxxx xxxx _B			

Serial Peripheral Interface

Drain-Source monitoring Threshold HS1-3

HS_VDS

VDS monitoring threshold HS1-3

(001 0011_B)

Reset Value: see [Table 57](#)

15	14	13	12	11	10	9	8	7	6	5	4	3	2	1	0
RES		RES	DEEP_ADAP	RES			HS3VDSTH			HS2VDSTH			HS1VDSTH		
r		rw		r			rw			rw			rw		

Field	Bits	Type	Description
RES	15:14	r	Reserved. Always read as 0
RES	13	rw	Reserved. This bit must be programmed to '0'
DEEP_ADAP	12	rw	Deep adaptation enable 0 _B NO_DEEP_ADAP , Deep adaptation disabled (default) 1 _B DEEP_ADAP , Deep adaptation enabled
RES	11:9	r	Reserved, always reads as 0
HS3VDSTH	8:6	rw	HS3 drain-source overvoltage threshold 000 _B 160mV , 0.16 V 001 _B 200mV , 0.20 V (default) 010 _B 300mV , 0.30 V 011 _B 400mV , 0.40 V 100 _B 500mV , 0.50 V 101 _B 600mV , 0.60 V 110 _B 800mV , 0.80 V 111 _B 2V , 2.0 V
HS2VDSTH	5:3	rw	HS2 drain-source overvoltage threshold 000 _B 160mV , 0.16 V 001 _B 200mV , 0.20 V (default) 010 _B 300mV , 0.30 V 011 _B 400mV , 0.40 V 100 _B 500mV , 0.50 V 101 _B 600mV , 0.60 V 110 _B 800mV , 0.80 V 111 _B 2V , 2.0 V
HS1VDSTH	2:0	rw	HS1 drain-source overvoltage threshold 000 _B 160mV , 0.16 V 001 _B 200mV , 0.20 V (default) 010 _B 300mV , 0.30 V 011 _B 400mV , 0.40 V 100 _B 500mV , 0.50 V 101 _B 600mV , 0.60 V 110 _B 800mV , 0.80 V 111 _B 2V , 2.0 V

Serial Peripheral Interface

Table 57 Reset of **HS_VDS**

Register Reset Type	Reset Values	Reset Short Name	Reset Mode	Note
POR/Soft reset	0000 0000 0100 1001 _B			
Restart	00xx 000x xxxx xxxx _B			

Serial Peripheral Interface

CCP and times selection

CCP_BLK

CCP and times selection

(001 0100_B)

Reset Value: see [Table 58](#)

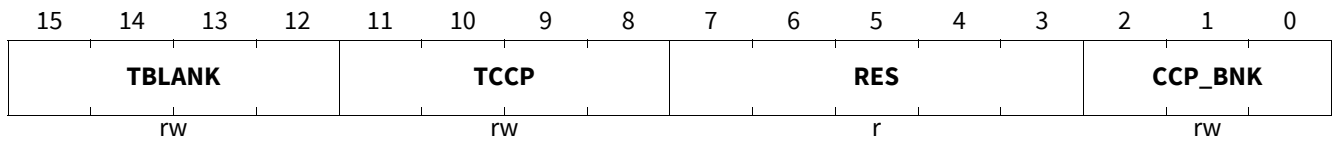

Field	Bits	Type	Description
TBLANK	15:12	rw	Blank time nom. tHBxBLANK = 587 ns + 266 x T[3:0] _D The CCP_BNK bits select the blank time for the FW or active MOSFET and the half-bridge HBx Reset of active and FW tHBxBLANK: 2450 ns typ.
TCCP	11:8	rw	Cross-current protection time nom. tHBxCCP = 587 ns + 266 x TCCP[3:0] _D The CCP_BNK bits select the cross-current protection time for the FW or active MOSFET and the half-bridge HBx Reset of all active and FW tHBxCCP: 2450 ns typ.
RES	7:3	r	Reserved, always reads as 0
CCP_BNK	2:0	rw	Cross-current and time banking 000 _B ACT_HB1 , Active blank and cross-current prot. times for HB1 (default) 001 _B ACT_HB2 , Active blank and cross-current prot. times for HB2 010 _B ACT_HB3 , Active blank and cross-current prot. times for HB3 011 _B RES , reserved 100 _B FW_HB1 , FW blank and cross-current prot. times for HB1 101 _B FW_HB2 , FW blank and cross-current prot. times for HB2 110 _B FW_HB3 , FW blank and cross-current prot. for times for HB3 111 _B RES , reserved

Table 58 Reset of **CCP_BLK**

Register Reset Type	Reset Values	Reset Short Name	Reset Mode	Note
POR/Soft reset	0111 0111 0000 0000 _B			
Restart	xxxx xxxx 0000 0000 _B			

Serial Peripheral Interface

Half-Bridge MODE

HBMODE

Half-Bridge MODE

(001 0101_B)

Reset Value: see [Table 59](#)

15	14	13	12	11	10	9	8	7	6	5	4	3	2	1	0
RES			HB3MODE		AFW3	HB3_PWM_EN	HB2MODE		AFW2	HB2_PWM_EN	HB1MODE		AFW1	HB1_PWM_EN	
r			rw		rw	rw	rw		rw	rw	rw		rw	rw	

Field	Bits	Type	Description
RES	15:12	r	Reserved, always reads as 0
HB3MODE	11:10	rw	Half-bridge 3 MODE selection 00 _B PASSIVE_OFF , LS3 and HS3 are off by passive discharge (default) 01 _B LS3_ON , LS3 is ON 10 _B HS3_ON , HS3 is ON 11 _B ACTIVE_OFF , LS3 and HS3 kept off by the active discharge
AFW3	9	rw	Active freewheeling for half-bridge 3 during PWM 0 _B DISABLED , active freewheeling disabled 1 _B ENABLED , active freewheeling enabled (default)
HB3_PWM_EN	8	rw	PWM mode for half-bridge 3 0 _B INACTIVE , PWM deactivated for HB2(default) 1 _B ACTIVE , PWM activated for HB2
HB2MODE	7:6	rw	Half-bridge 2 MODE selection 00 _B PASSIVE_OFF , LS2 and HS2 are off by passive discharge (default) 01 _B LS2_ON , LS2 is ON 10 _B HS2_ON , HS2 is ON 11 _B ACTIVE_OFF , LS2 and HS2 kept off by the active discharge
AFW2	5	rw	Active freewheeling for half-bridge 2 during PWM 0 _B DISABLED , active freewheeling disabled 1 _B ENABLED , active freewheeling enabled (default)
HB2_PWM_EN	4	rw	PWM mode for half-bridge 2 0 _B INACTIVE , PWM deactivated for HB2(default) 1 _B ACTIVE , PWM activated for HB2
HB1MODE	3:2	rw	Half-bridge 1 MODE selection 00 _B PASSIVE_OFF , LS1 and HS1 are off by passive discharge (default) 01 _B LS1_ON , LS1 is ON 10 _B HS1_ON , HS1 is ON 11 _B ACTIVE_OFF , LS1 and HS1 kept off by the active discharge

Serial Peripheral Interface

Field	Bits	Type	Description
AFW1	1	rw	Active freewheeling for half-bridge 1 during PWM 0 _B DISABLED , active freewheeling disabled 1 _B ENABLED , active freewheeling enabled (default)
HB1_PWM_EN	0	rw	PWM mode for half-bridge 1 0 _B INACTIVE , PWM deactivated for HB1 (default) 1 _B ACTIVE , PWM activated for HB1

Table 59 Reset of **HBMODE**

Register Reset Type	Reset Values	Reset Short Name	Reset Mode	Note
POR/Soft reset	0000 0010 0010 0010 _B			
Restart	0000 0010 0010 0010 _B			

Serial Peripheral Interface

HB pre-charge and pre-discharge time

TPRECHG

HB pre-charge and pre-discharge time (001 0110_B) Reset Value: see Table 60

15	14	13	12	11	10	9	8	7	6	5	4	3	2	1	0
RES		TPCHG3			TPCHG2			TPCHG1		RES	TPCHG_BNK				
r		rw			rw			rw		r	rw				

Field	Bits	Type	Description
RES	15:13	r	Reserved, always reads as 0
TPCHG3	12:10	rw	If TPCHG_BNK=0: precharge time of HB 3, If TPCHG_BNK=1: pre-discharge time of HB 3
TPCHG2	9:7	rw	If TPCHG_BNK=0: precharge time of HB 2, If TPCHG_BNK=1: pre-discharge time of HB 2
TPCHG1	6:4	rw	If TPCHG_BNK=0: precharge time of HB 1, If TPCHG_BNK=1: pre-discharge time of HB 1
RES	3	r	Reserved, always read as 0
TPCHG_BNK	2:0	rw	Precharge/pre-discharge time selection 000 _B PRECHARGE, Precharge time selected (default) 001 _B PREDISCHARGE, Pre-discharge time selected x1x _B , wrong setting of TPCHG_BNK 1xx _B , wrong setting of TPCHG_BNK

Table 60 Reset of TPRECHG

Register Reset Type	Reset Values	Reset Short Name	Reset Mode	Note
POR/Soft reset	0000 0000 0000 0000 _B			
Restart	000x xxxx xxxx 0000 _B			

Serial Peripheral Interface

Static charge/discharge current

ST_ICHG

Static charge/discharge current

(001 0111_B)

Reset Value: see [Table 61](#)

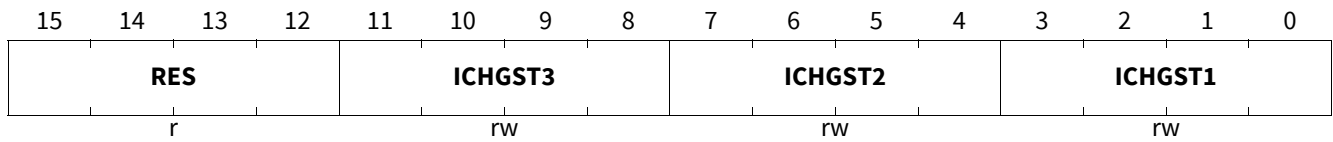

Field	Bits	Type	Description
RES	15:12	r	Reserved, always read as 0
ICHGST3	11:8	rw	Static charge and discharge currents of HB3 Refer to Table 20 Default: 0100 _B - charge: I_{CHG16} , 15.3 mA typ., discharge: I_{DCHG16} , 15.1 mA typ.
ICHGST2	7:4	rw	Static charge and discharge currents of HB2 Refer to Default: 0100 _B - charge: I_{CHG16} , 15.3 mA typ., discharge: I_{DCHG16} , 15.1 mA typ.
ICHGST1	3:0	rw	Static charge and discharge currents of HB1 Refer to Table 20 Default: 0100 _B - charge: I_{CHG16} , 15.3 mA typ., discharge: I_{DCHG16} , 15.1 mA typ.

Table 61 Reset of [ST_ICHG](#)

Register Reset Type	Reset Values	Reset Short Name	Reset Mode	Note
POR/Soft reset	0000 0100 0100 0100 _B			
Restart	0000 xxxx xxxx xxxx _B			

Serial Peripheral Interface

HB charge/discharge currents for PWM operation

HB_ICHG

HB charge/discharge currents for PWM operation

(001 1000_B)

Reset Value: see [Table 62](#)

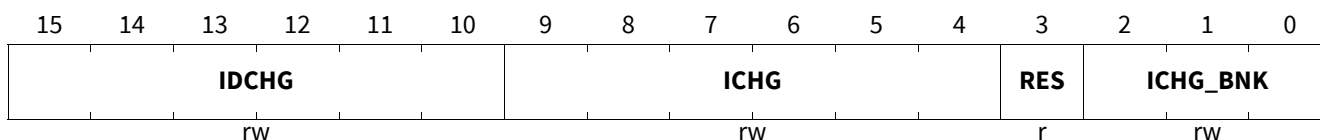

Field	Bits	Type	Description
IDCHG	15:10	rw	<p>If ICHG_BNK=0xx_B: Discharge current of HBx active MOSFET</p> <p>If ICHG_BNK=1xx_B: Reserved. Always read as '0'</p> <p>Default value for all active MOSFETs discharge currents: 001111_B, I_{DCHG15}</p> <p>Refer to Table 28 for the configuration of the discharge current</p>
ICHG	9:4	rw	<p>If ICHG_BNK=0xx_B: Charge current of HBx active MOSFET</p> <p>If ICHG_BNK=1xx_B: Charge and discharge current of HBx FW MOSFETs</p> <p>Default value for all active MOSFETs charge currents and all FW MOSFETs charge/discharge currents: 001101_B, I_{CHG13}</p> <p>Refer to Table 27 for the configuration of the charge current of the active and FW MOSFET</p> <p>Refer to Table 28 for the configuration of the discharge current of the FW MOSFET</p>
RES	3	r	Reserved, always read as 0
ICHG_BNK	2:0	rw	<p>Banking bits for charge and discharge currents of active MOSFETs</p> <p>000_B ACT_HB1, Active MOSFET of HB1 is selected (default)</p> <p>001_B ACT_HB2, Active MOSFET of HB2 is selected</p> <p>010_B ACT_HB3, Active MOSFET of HB3 is selected</p> <p>011_B RES, reserved</p> <p>100_B FW_HB1, FW MOSFET of HB1 is selected</p> <p>101_B FW_HB2, FW MOSFET of HB2 is selected</p> <p>110_B FW_HB3, FW MOSFET of HB3 is selected</p> <p>111_B RES, reserved</p>

Table 62 Reset of **HB_ICHG**

Register Reset Type	Reset Values	Reset Short Name	Reset Mode	Note
POR/Soft reset	0011 1100 1101 0000 _B			POR value valid for ICHG_BNK = 0
Restart	xxxx xxxx xxxx 0000 _B			

Serial Peripheral Interface

HB max. pre-charge/pre-discharge in PWM operation current and diagnostic pull-down

HB_ICHG_MAX

HB max. pre-charge/pre-discharge in PWM operation current and diagnostic pull-down

(001 1001_B)

Reset Value: see [Table 63](#)

15	14	13	12	11	10	9	8	7	6	5	4	3	2	1	0
RES	HB3ID IAG	HB2ID IAG	HB1ID IAG	RES			RES	ICHGMAX3		ICHGMAX2		ICHGMAX1			
r	rrw	rw	rw	r			r	rw		rw		rw			

Field	Bits	Type	Description
RES	15	r	Reserved, always read as 0
HB3IDIAG	14	rrw	Control of HB3 off-state current source and current sink 0 _B INACTIVE , Pull-down deactivated (default) 1 _B ACTIVE , Pull-down activated
HB2IDIAG	13	rw	Control of HB2 pull-down for off-state diagnostic 0 _B INACTIVE , Pull-down deactivated (default) 1 _B ACTIVE , Pull-down activated
HB1IDIAG	12	rw	Control of HB1 pull-down for off-state diagnostic 0 _B INACTIVE , Pull-down deactivated (default) 1 _B ACTIVE , Pull-down activated
RES	11:8	r	Reserved, always read as 0
RES	7:6	r	Reserved, always reads as 0
ICHGMAX3	5:4	rw	Maximum drive current of HB3 during the pre-charge and pre-discharge phases ¹⁾ 00 _B 31mA , charge I _{CHG24} : typ. 31.6 mA, discharge I _{DCHG24} : typ. 30.9 mA (default) 01 _B 52mA , charge I _{CHG32} : typ. 52.5 mA, discharge I _{DCHG32} : typ. 51.5 mA 10 _B 112mA , charge I _{CHG52} : typ. 112.2mA, discharge I _{DCHG52} : typ. 110.8 mA 11 _B 150mA , charge I _{CHG63} : typ. 150 mA, discharge I _{DCHG63} : typ. 150 mA
ICHGMAX2	3:2	rw	Maximum drive current of HB2 during the pre-charge phase and pre-discharge phases ¹⁾ 00 _B 31mA , charge I _{CHG24} : typ. 31.6 mA, discharge I _{DCHG24} : typ. 30.9 mA (default) 01 _B 52mA , charge I _{CHG32} : typ. 52.5 mA, discharge I _{DCHG32} : typ. 51.5 mA 10 _B 112mA , charge I _{CHG52} : typ. 112.2mA, discharge I _{DCHG52} : typ. 110.8 mA 11 _B 150mA , charge I _{CHG63} : typ. 150 mA, discharge I _{DCHG63} : typ. 150 mA

Serial Peripheral Interface

Field	Bits	Type	Description
ICHGMAX1	1:0	rw	<p>Maximum drive current of HB1 during the pre-charge and pre-discharge phases¹⁾</p> <p>00_B 31mA, charge I_{CHG24}: typ. 31.6 mA, discharge I_{DCHG24}: typ. 30.9 mA (default)</p> <p>01_B 52mA, charge I_{CHG32}: typ. 52.5 mA, discharge I_{DCHG32}: typ. 51.5 mA</p> <p>10_B 112mA, charge I_{CHG52}: typ. 112.2mA, discharge I_{DCHG52}: typ. 110.8 mA</p> <p>11_B 150mA, charge I_{CHG63}: typ. 150 mA, discharge I_{DCHG63}: typ. 150 mA</p>

1) ICHGMAX is also the current applied during the post-charge of the PWM MOSFET.

Table 63 Reset of **HB_ICHG_MAX**

Register Reset Type	Reset Values	Reset Short Name	Reset Mode	Note
POR/Soft reset	0000 0000 0000 0000 _B			
Restart	0xxx 0000 00xx xxxx _B			

Serial Peripheral Interface

HBx pre-charge/pre-discharge initialization configuration in PWM operation

HB_PCHG_INIT

HBx pre-charge/pre-discharge initialization configuration in PWM operation

(001 1010_B)

Reset Value: see [Table 64](#)

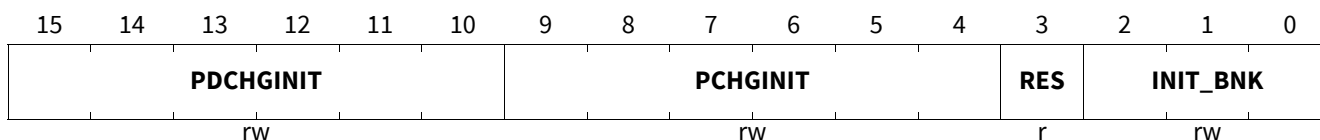

Field	Bits	Type	Description
PDCHGINIT	15:10	rw	Initial predischARGE current of HBx, IPDCHGINITx The INIT_BNK bits select the addressed half-bridge Default: 001111 _B Refer to Table 27
PCHGINIT	9:4	rw	Initial precharge current of HBx, IPCHGINITx The INIT_BNK bits select the addressed half-bridge Default: 001101 _B Refer to Table 27
RES	3	r	Reserved, always reads as 0
INIT_BNK	2:0	rw	Banking bits for Precharge an PredischARGE Initial Current 000 _B HB1 , precharge/dischARGE init. for HB1 selected (default) 001 _B HB2 , precharge/dischARGE init. for HB2 selected 010 _B HB3 , precharge/dischARGE init. for HB3 selected 010 _B RES , reserved 011 _B RES , reserved 1xx _B , wrong setting of INIT_BANK

Table 64 Reset of [HB_PCHG_INIT](#)

Register Reset Type	Reset Values	Reset Short Name	Reset Mode	Note
POR/Soft reset	0011 1100 1101 0000 _B			
Restart	xxxx xxxx xxxx 0000 _B			

Serial Peripheral Interface

HBx inputs TDON configuration

TDON_HB_CTRL

HBx inputs TDON configuration

(001 1011_B)

Reset Value: see [Table 65](#)

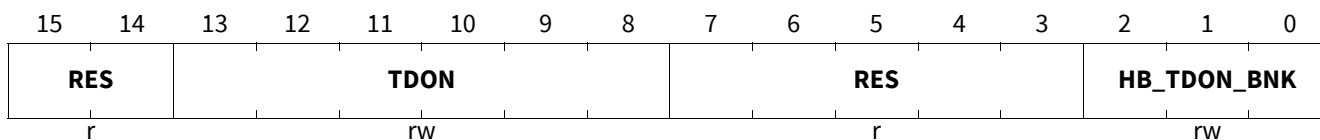

Field	Bits	Type	Description
RES	15:14	r	Reserved, always read as 0
TDON	13:8	rw	Turn-on delay time of active MOSFET of HBx The HB_TDON_BNK bits selects the turn-on delay time of the active MOSFET of the half-bridge HBx Nominal tDON = 53.3 ns x TDON[5:0] _D Default: 00 1100 _B : 640 ns typ.
RES	7:3	r	Reserved, always read as 0
HB_TDON_BNK	2:0	rw	Banking bits for turn-on delay time 000 _B HB1 , tDON of HB1 selected (default) 001 _B HB2 , tDON of HB2 selected 010 _B HB3 , tDON of HB3 selected 011 _B RES , reserved 1xx _B , wrong setting of PWM_TDON_BNK

Table 65 Reset of **TDON_HB_CTRL**

Register Reset Type	Reset Values	Reset Short Name	Reset Mode	Note
POR/Soft reset	0000 1100 0000 0000 _B			
Restart	00xx xxxx 0000 0000 _B			

Serial Peripheral Interface

HBx TDOFF configuration

TDOFF_HB_CTRL

HBx TDOFF configuration

(001 1100_B)

Reset Value: see [Table 66](#)

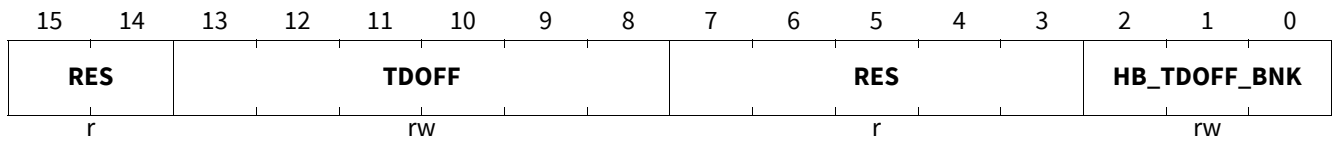

Field	Bits	Type	Description
RES	15:14	r	Reserved, always read as 0
TDOFF	13:8	rw	Turn-off delay time of active MOSFET of HBx The HB_TDOFF_BNK bits selects the turn-off delay time of the active MOSFET of the half-bridge HBx Nominal tDOFF = 53.3 ns x TDOFF[5:0] _D Default: 0000 1100 _B : 640 ns
RES	7:3	r	Reserved, always read as 0
HB_TDOFF_BNK	2:0	rw	Banking bits for turn-off delay time 000 _B HB1 , tDOFF of HB1 selected (default) 001 _B HB2 , tDOFF of HB2 selected 010 _B HB3 , tDOFF of HB3 selected 1xx _B , wrong setting of PWM_TDOFF_BNK

Table 66 Reset of **TDOFF_HB_CTRL**

Register Reset Type	Reset Values	Reset Short Name	Reset Mode	Note
POR/Soft reset	0000 1100 0000 0000 _B			
Restart	00xx xxxx 0000 0000 _B			

Serial Peripheral Interface

Brake control

BRAKE

Brake control

(001 1101_B)

Reset Value: see [Table 67](#)

15	14	13	12	11	10	9	8	7	6	5	4	3	2	1	0
RES	RES	SLAM _LS3_ DIS	SLAM _LS2_ DIS	SLAM _LS1_ DIS	SLAM	VDST H_BR K	TBLK BRK	PARK_ BRK_E N	OV_B RK_E N	RES	RES	RES	RES	RES	OV_BRK_TH
r	r	rw	rw	rw	rw	rw	rw	rw	rw	rw	rw	rw	rw	rw	rw

Field	Bits	Type	Description
RES	15:14	r	Reserved, always read as 0
RES	13	r	Reserved, always read as 0
SLAM_LS3_DIS	12	rw	LS3 output disable during SLAM mode 0 _B ACTIVE , LS3 control active in Slam mode (default) 1 _B DISABLED , LS3 control disabled in Slam mode
SLAM_LS2_DIS	11	rw	LS2 output disable during SLAM mode 0 _B ACTIVE , LS2 control active in Slam mode (default) 1 _B DISABLED , LS2 control disabled in Slam mode
SLAM_LS1_DIS	10	rw	LS1 output disable during SLAM mode 0 _B ACTIVE , LS1 control active in Slam mode (default) 1 _B DISABLED , LS1 control disabled in Slam mode
SLAM	9	rw	Slam mode 0 _B INACTIVE , Slam mode deactivated (default) 1 _B ACTIVE , Slam mode activated
VDSTH_BRK	8	rw	VDS Overvoltage for LS1-3 during braking 0 _B 800mV , $V_{VDSMONTH0_BRAKE}$: 0.8 V, typ. (default) 1 _B 220mV , $V_{VDSMONTH1_BRAKE}$: 0.22 V typ.
TBLK_BRK	7	rw	Blank time of VDS overvoltage during braking 0 _B 7uS , t_{BLK_BRAKE1} : 7 μs typ. 1 _B 11uS , t_{BLK_BRAKE2} : 11 μs typ. (default)
PARK_BRK_EN	6	rw	Parking brake enable 0 _B DISABLED , Parking brake disabled (default) 1 _B ENABLED , Parking brake enabled
OV_BRK_EN	5	rw	Overvoltage brake enable 0 _B DISABLED , Overvoltage brake disabled 1 _B ENABLED , Overvoltage brake enabled (default)
RES	4:3	rw	Reserved, to be set to 0

Serial Peripheral Interface

Field	Bits	Type	Description
OV_BRK_TH	2:0	rw	Overvoltage brake threshold 000 _B 27V , typ. 27V (default) 001 _B 28V , typ. 28V 010 _B 29V , typ. 29V 011 _B 30V , typ. 30V 100 _B 31V , typ. 31V 101 _B 32V , typ. 32V 110 _B 33V , typ. 33V 111 _B 34V , typ. 34V

Table 67 Reset of **BRAKE**

Register Reset Type	Reset Values	Reset Short Name	Reset Mode	Note
POR/Soft reset	0000 0000 1010 0000 _B			
Restart	000x xxxx xxx0 0xxx _B			

Note: For min and max values of **OV_BRK_TH**, refer to **Chapter 12.12**.

Serial Peripheral Interface

13.6 SPI status information registers

READ/CLEAR Operation (see also [Chapter 13.3](#)):

- One 32-bit SPI command consist of four bytes:
 - The 7-bit address and one additional bit for the register access mode and
 - following the two data bytes and the CRC.
 The numbering of following bit definitions refers to the data byte and correspond to the bits D0...D7 and to the SPI bits 8...23 (see also figure).
- There are two different bit types:
 - ‘r’ = READ: read only bits (or reserved bits).
 - ‘rc’ = READ/CLEAR: readable and clearable bits.
- Reading a register is done word wise by setting the SPI bit 7 to “0” (= Read Only).
- Clearing a register is done word wise by setting the SPI bit 7 to “1”. No single bits can be cleared. Therefore the content of a SPI message (bit 8..23) doesn’t matter.
- SPI status registers are in general not cleared or changed automatically (an exception are the x bits). This must be done by the microcontroller via SPI command.

The registers are addressed wordwise.

Table 68 Register Overview

Register Short Name	Register Long Name	Offset Address	Page Number
SPI status information registers, Device Status Registers			
SUP_STAT	Supply Voltage Fail Status	1000000 _B	196
THERM_STAT	Thermal Protection Status	1000001 _B	198
DEV_STAT	Device Information Status	1000010 _B	199
BUS_STAT	Bus Communication Status	1000011 _B	201
WK_STAT	Wake-up Source and Information Status	1000100 _B	202
WK_LVL_STAT	WK Input Level	1000101 _B	203
HS_OL_OC_OT_STAT	High-Side Switch Status	1000110 _B	204
SPI status information registers, Status registers bridge driver			
GEN_STAT	GEN Status register	1010000 _B	206
TDREG	Turn-on/off delay regulation register	1010001 _B	208
DSOV	Drain-source overvoltage HBVOUT	1010010 _B	210
EFF_TDON_OFF1	Effective MOSFET turn-on/off delay - PWM half-bridge 1	1010011 _B	212
EFF_TDON_OFF2	Effective MOSFET turn-on/off delay - PWM half-bridge 2	1010100 _B	213
EFF_TDON_OFF3	Effective MOSFET turn-on/off delay - PWM half-bridge 3	1010101 _B	214
TRISE_FALL1	MOSFET rise/fall time - PWM half-bridge 1	1010111 _B	215
TRISE_FALL2	MOSFET rise/fall time - PWM half-bridge 2	1011000 _B	216
TRISE_FALL3	MOSFET rise/fall time - PWM half-bridge 3	1011001 _B	217
SPI status information registers, Family and product information register			
FAM_PROD_STAT	Family and Product Identification Register	1110000 _B	218

Serial Peripheral Interface

13.6.1 Device Status Registers

Supply Voltage Fail Status

SUP_STAT

Supply Voltage Fail Status

(100 0000_B)

Reset Value: see [Table 69](#)

15	14	13	12	11	10	9	8	7	6	5	4	3	2	1	0
POR	RES	CP_OT	VCC1_UV_FS	HS_UV	HS_OV	VSINT_UV	VSINT_OV	VS_UV	VS_OV	CP_UV	VCC1_SC	VCC1_UV	VCC1_OV	VCC1_WARN	
rc	r	rc	rc	rc	rc	rc	rc	rc	rc	rc	rc	rc	rc	rc	rc

Field	Bits	Type	Description
POR	15	rc	Power-On reset detection 0 _B NO_POR, No POR 1 _B POR, POR occurred
RES	14:13	r	Reserved, always reads as 0
CP_OT	12	rc	Charge pump overtemperature 0 _B NO_CP_OT, No charge pump OT detected 1 _B CP_OT, Charge pump OT detected
VCC1_UV_FS	11	rc	4th consecutive VCC1 UV-Detection 0 _B NO_FAILSAFE, No Fail-Safe Mode entry due to 4th consecutive VCC1_UV 1 _B FAILSAFE, Fail-Safe Mode entry due to 4th consecutive VCC1_UV
HS_UV	10	rc	HS Supply UV-Detection 0 _B NO_UV, No Undervoltage 1 _B UV_EVENT, HS Supply Undervoltage detected
HS_OV	9	rc	HS Supply OV-Detection 0 _B NO_OV, No Overvoltage 1 _B OV_EVENT, HS Supply Overvoltage detected
VSINT_UV	8	rc	VSINT UV-Detection 0 _B NO_UV, No Undervoltage 1 _B UV_EVENT, VSINT Undervoltage detected
VSINT_OV	7	rc	VSINT OV-Detection 0 _B NO_OV, No Overvoltage 1 _B OV_EVENT, VSINT Overvoltage detected
VS_UV	6	rc	VS Undervoltage Detection (V_{s,uv}) 0 _B NO_VS, No VS undervoltage detected 1 _B VS_EVENT, VS undervoltage detected (detection is only active when VCC1 is enabled)
VS_OV	5	rc	VS Overvoltage Detection (V_{s,ov}) 0 _B NO_OV, No VS overvoltage detected 1 _B OV_EVENT, VS overvoltage detected (detection is only active when VCC1 is enabled)

Serial Peripheral Interface

Field	Bits	Type	Description
CP_UV	4	rc	CP_UV 0 _B NO_UV , No CP undervoltage detected 1 _B UV_EVENT , CP undervoltage detected
VCC1_SC	3	rc	VCC1 SC 0 _B NO_SC , No VCC1 short to GND detected 1 _B SC_EVENT , VCC1 short to GND
VCC1_UV	2	rc	VCC1 UV-Detection (due to Vrtx reset) 0 _B NO_UV , No VCC1_UV detection 1 _B UV_EVENT , VCC1 undervoltage detected
VCC1_OV	1	rc	VCC1 Overvoltage Detection 0 _B NO_OV , No VCC1 overvoltage warning 1 _B OV_EVENT , VCC1 overvoltage detected
VCC1_WARN	0	rc	VCC1 Undervoltage Prewarning 0 _B NO_UV , No VCC1 undervoltage prewarning 1 _B UV_PREWARN , VCC1 undervoltage prewarning detected

Table 69 Reset of SUP_STAT

Register Reset Type	Reset Values	Reset Short Name	Reset Mode	Note
POR/Soft reset	y000 0000 0000 0000 _B			
Restart	x00x xxxx xxxx xxxx _B			

Notes

1. The VCC1 undervoltage prewarning threshold $V_{PW,f}/V_{PW,r}$ is a fixed threshold and independent of the VCC1 undervoltage reset thresholds.
2. VSINT undervoltage monitoring is not available in Stop Mode due to current consumption saving requirements. Exception: VSINT undervoltage detection is also available in Stop Mode if the VCC1 load current is above the active peak threshold (I_{PEAK_TH}) or if VCC1 is below the VCC1 prewarning threshold (**VCC1_WARN** is set).
3. The MSB of the POR/Soft Reset value is marked as 'y': the default value of the POR bit is set after Power-on reset (POR value = 1000 0000). However it will be cleared after a device Soft Reset command (Soft Reset value = 0000 0000).
4. During Sleep Mode, the bits VCC1_SC, VCC1_OV and VCC1_UV will not be set when VCC1 is off.
5. The VCC1_UV bit is never updated in Restart Mode, in Init Mode it is only updated after RSTN was released, it is always updated in Normal Mode and Stop Mode, and it is always updated in any device modes in a VCC1_SC condition (after VCC1_UV = 1 for > 2 ms).

Serial Peripheral Interface

Thermal Protection Status

THERM_STAT

Thermal Protection Status

(100 0001_B)

Reset Value: see [Table 70](#)

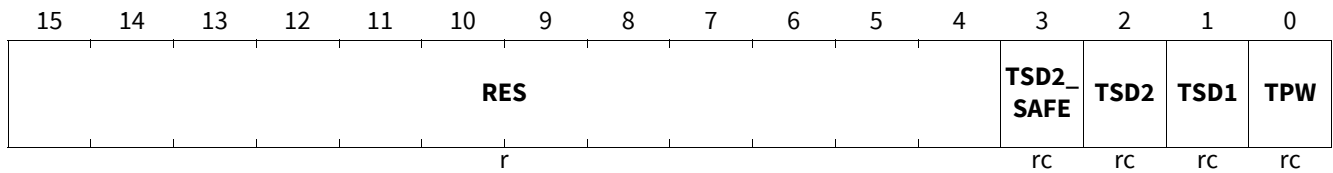

Field	Bits	Type	Description
RES	15:4	r	Reserved, always reads as 0
TSD2_SAFE	3	rc	TSD2 Thermal Shut-Down Safe State Detection 0 _B NO_TSD2_SF , No TSD2 safe state detected 1 _B TSD2_SF , TSD2 safe state detected: >16 consecutive TSD2 events occurred, next TSD2 waiting time will be 64s
TSD2	2	rc	TSD2 Thermal Shut-Down Detection 0 _B NO_TSD2 , No TSD2 event 1 _B TSD2_EVENT , TSD2 OT detected - leading to Fail-Safe Mode
TSD1	1	rc	TSD1 Thermal Shut-Down Detection 0 _B NO_TSD1 , No TSD1 fail 1 _B TSD1_EVENT , TSD1 OT detected (affected module is disabled)
TPW	0	rc	Thermal Pre Warning 0 _B NO_TPW , No Thermal Pre warning 1 _B TPW , Thermal Pre warning detected

Table 70 Reset of **THERM_STAT**

Register Reset Type	Reset Values	Reset Short Name	Reset Mode	Note
POR/Soft reset	0000 0000 0000 0000 _B			
Restart	0000 0000 0000 xxxx _B			

Note: Temperature warning and shutdown bits are not reset automatically, even if the temperature pre warning or the TSD condition is not present anymore.

Serial Peripheral Interface

Device Information Status

DEV_STAT

Device Information Status

(100 0010_B)

Reset Value: see [Table 71](#)

15	14	13	12	11	10	9	8	7	6	5	4	3	2	1	0
RES						CRC_S TAT	CRC_F AIL	DEV_STAT	RES	SW_D EV	WD_FAIL	SPI_F AIL	FAILU RE		
r						r	rc	rc	r	rh	rh	rc	rc		

Field	Bits	Type	Description
RES	15:10	r	Reserved, always read as 0
CRC_STAT	9	r	CRC STAT Information 0 _B DISABLED , CRC disabled 1 _B ENABLED , CRC enabled
CRC_FAIL	8	rc	CRC Fail Information¹⁾ 0 _B NO_FAIL , No CRC Failure 1 _B FAIL , CRC Failure detected
DEV_STAT	7:6	rc	Device Status before Restart Mode 00 _B CLEARED , Cleared (Register must be actively cleared) 01 _B RESTART , Restart due to failure (WD fail, TSD2, VCC1_UV, trial to access Sleep Mode without any wake source activated); also after a wake from Fail-Safe Mode 10 _B SLEEP , Sleep Mode 11 _B , reserved
RES	5	r	Reserved, always reads 0
SW_DEV	4	rh	Status of Operating Mode 0 _B NORMAL , Normal operation 1 _B SW_DEV , Software Development Mode is enabled
WD_FAIL	3:2	rh	Number of WD-Failure Events 00 _B NO_FAIL , No WD Fail 01 _B 1x , 1x WD Fail, 10 _B 2x , 2x WD Fail 11 _B 3x , more than 3xWD Fail
SPI_FAIL	1	rc	SPI Fail Information 0 _B NO_FAIL , No SPI fail 1 _B INVALID , Invalid SPI command detected
FAILURE	0	rc	Failure detection 0 _B NO_FAIL , No Failure 1 _B FAIL , Failure occurred

1) The CRC_FAIL bit will not be set in case the static CRC enabling / disabling sequence is sent (see [Chapter 5.2](#)).

Serial Peripheral Interface

Table 71 Reset of **DEV_STAT**

Register Reset Type	Reset Values	Reset Short Name	Reset Mode	Note
POR/Soft reset	0000 0000 0000 0000 _B			
Restart	0000 00xx xx0x xxxx _B			

Notes

1. The bits **DEV_STAT** show the status of the device before exiting Restart Mode. Either the device came from regular Sleep Mode or a failure (Restart Mode or Fail-Safe Mode) occurred. Coming from Sleep Mode will also be shown if there was a trial to enter Sleep Mode without having cleared all wake flags before.
2. The **WD_FAIL** bits are implemented as a counter and are the only status bits, which are cleared automatically by the device.
3. The **SPI_FAIL** bit can only be cleared via SPI command.
4. The bit **CRC_STAT** and **CRC_FAIL** can be read regardless the CRC setting. The SPI read command on **DEV_STAT** ignores the CRC field.

Serial Peripheral Interface

Bus Communication Status

BUS_STAT

Bus Communication Status

(100 0011_B)

Reset Value: see [Table 72](#)

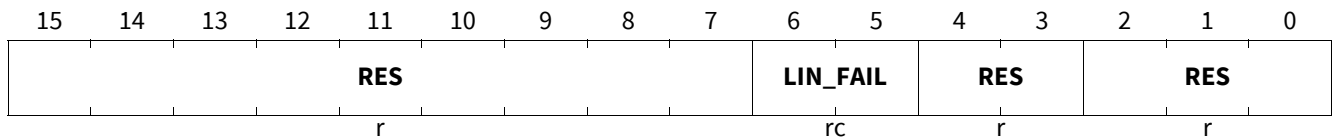

Field	Bits	Type	Description
RES	15:7	r	Reserved, always reads as 0
LIN_FAIL	6:5	rc	LIN failure status 00 _B NO_FAIL , No failures 01 _B LIN_TSD , LIN Thermal shutdown 10 _B LIN_TXD_DOM_TO , LIN_TXD_DOM: detected a TXDLIN dominant timeout 11 _B LIN_BUS_DOM_TO , LIN_BUS_DOM: detected a LIN dominant timeout
RES	4:3	r	Reserved, always reads as 0
RES	2:0	r	Reserved, always reads as 0

Table 72 Reset of [BUS_STAT](#)

Register Reset Type	Reset Values	Reset Short Name	Reset Mode	Note
POR/Soft reset	0000 0000 0000 0000 _B			
Restart	0000 0000 0xxx xxxx _B			

Notes

1. The VCAN_UV comparator is enabled if CAN Normal or CAN Receive Only Mode.

Serial Peripheral Interface

Wake-up Source and Information Status

WK_STAT

Wake-up Source and Information Status

(100 0100_B)

Reset Value: see [Table 73](#)

15	14	13	12	11	10	9	8	7	6	5	4	3	2	1	0
RES					LIN_WU	RES	TIMER2_WU	TIMER1_WU	RES		RES	WK4_WU	RES	RES	RES
r					rc	r	rc	rc	r		r	rc	r	r	r

Field	Bits	Type	Description
RES	15:11	r	Reserved, always reads as 0
LIN_WU	10	rc	LIN wake up 0 _B NO_WU, No Wake up 1 _B WU, Wake up detected
RES	9	r	Reserved, always reads as 0
TIMER2_WU	8	rc	Wake up via Timer2 0 _B NO_WU, No Wake up 1 _B WU, Wake up detected
TIMER1_WU	7	rc	Wake up via Timer1 0 _B NO_WU, No Wake up 1 _B WU, Wake up detected
RES	6:5	r	Reserved, always reads as 0
RES	4	r	Reserved, always reads as 0
WK4_WU	3	rc	Wake up via WK4 0 _B NO_WU, No Wake up 1 _B WU, Wake up detected
RES	2	r	Reserved, always reads as 0
RES	1	r	Reserved, always reads as 0
RES	0	r	Reserved, always reads as 0

Table 73 Reset of [WK_STAT](#)

Register Reset Type	Reset Values	Reset Short Name	Reset Mode	Note
POR/Soft reset	0000 0000 0000 0000 _B			
Restart	0000 0xxx x000 00x0 _B			

Note: At Fail-Safe Mode entry, the [WK_STAT](#) register is automatically cleared by the device.

Serial Peripheral Interface

WK Input Level

WK_LVL_STAT

WK Input Level

(100 0101_B)

Reset Value: see [Table 74](#)

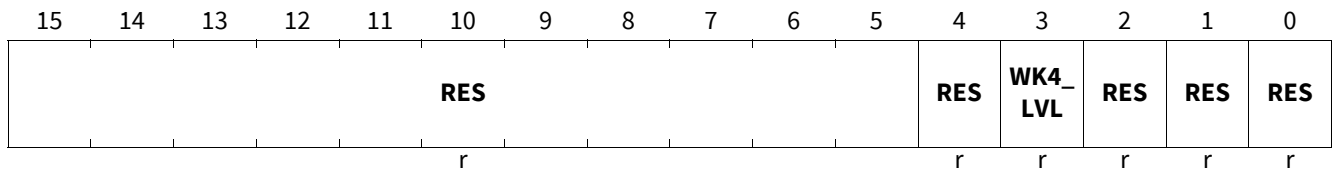

Field	Bits	Type	Description
RES	15:5	r	Reserved, always reads as 0
RES	4	r	Reserved, always reads as 0
WK4_LVL	3	r	Status of WK4 0 _B LOW , Low Level (=0) 1 _B HIGH , High Level (=1)
RES	2	r	Reserved, always reads as 0
RES	1	r	Reserved, always reads as 0
RES	0	r	Reserved, always reads as 0

Table 74 Reset of [WK_LVL_STAT](#)

Register Reset Type	Reset Values	Reset Short Name	Reset Mode	Note
POR/Soft reset	0000 0000 0000 00x0 _B			
Restart	0000 0000 0000 00x0 _B			

Note: WK_LVL_STAT is updated in Normal Mode and Stop Mode and also in Init and Restart Mode. In cyclic sense or wake mode, the registers contain the sampled level, i.e. the registers are updated after every sampling.

Serial Peripheral Interface

High-Side Switch Status

HS_OL_OC_OT_STAT

High-Side Switch Status

(100 0110_B)

Reset Value: see [Table 75](#)

15	14	13	12	11	10	9	8	7	6	5	4	3	2	1	0
RES	RES	HS3_OT	HS2_OT	HS1_OT	RES	RES	HS3_OL	HS2_OL	HS1_OL	RES	RES	HS3_OC	HS2_OC	HS1_OC	
r	r	rc	rc	rc	r	r	rc	rc	rc	r	r	rc	rc	rc	

Field	Bits	Type	Description
RES	15:14	r	Reserved, always reads as 0
RES	13	r	Reserved, always reads as 0
HS3_OT	12	rc	Overtemperature Detection on HS3 0 _B NO_OT, No OT 1 _B OT, OT detected
HS2_OT	11	rc	Overtemperature Detection on HS2 0 _B NO_OT, No OT 1 _B OT, OT detected
HS1_OT	10	rc	Overtemperature Detection on HS1 0 _B NO_OT, No OT 1 _B OT, OT detected
RES	9	r	Reserved, always reads as 0
RES	8	r	Reserved, always reads as 0
HS3_OL	7	rc	Open-Load Detection on HS3 0 _B NO_OL, No OL 1 _B OL, OL detected
HS2_OL	6	rc	Open-Load Detection on HS2 0 _B NO_OL, No OL 1 _B OL, OL detected
HS1_OL	5	rc	Open-Load Detection on HS1 0 _B NO_OL, No OL 1 _B OL, OL detected
RES	4	r	Reserved, always reads as 0
RES	3	r	Reserved, always reads as 0
HS3_OC	2	rc	Overcurrent Detection on HS3 0 _B NO_OC, No OC 1 _B OC, OC detected
HS2_OC	1	rc	Overcurrent Detection on HS2 0 _B NO_OC, No OC 1 _B OC, OC detected
HS1_OC	0	rc	Overcurrent Detection on HS1 0 _B NO_OC, No OC 1 _B OC, OC detected

Serial Peripheral Interface

Table 75 Reset of **HS_OL_OC_OT_STAT**

Register Reset Type	Reset Values	Reset Short Name	Reset Mode	Note
POR/Soft reset	0000 0000 0000 0000 _B			
Restart	00xx xxxx xxxx xxxx _B			

Serial Peripheral Interface

13.6.2 Status registers bridge driver

General Status register

GEN_STAT

General Status register

(101 0000_B)

Reset Value: see [Table 76](#)

15	14	13	12	11	10	9	8	7	6	5	4	3	2	1	0
RES						RES	HB3V OUT	HB2V OUT	HB1V OUT	PWM6 STAT	PWM5 STAT	PWM4 STAT	PWM3 STAT	PWM2 STAT	PWM1 STAT
r						r	r	r	r	r	r	r	r	r	r

Field	Bits	Type	Description
RES	15:10	r	Reserved, always reads as 0
RES	9	r	Reserved, always reads as 0
HB3VOUT	8	r	Voltage level at VSH3 when HB3MODE[1:0] = 11 and CPEN=1 ¹⁾ 0 _B LOW, VSH3 = Low : VS - VSH3 > V _{HS3VDSTHx} 1 _B HIGH, VSH3 = High: VS - VSH3 ≤ V _{HS3VDSTHx}
HB2VOUT	7	r	Voltage level at VSH2 when HB2MODE[1:0] = 11 and CPEN=1 ¹⁾ 0 _B LOW, VSH2 = Low : VS - VSH2 > V _{HS2VDSTHx} 1 _B HIGH, VSH2 = High: VS - VSH2 ≤ V _{HS2VDSTHx}
HB1VOUT	6	r	Voltage level at VSH1 when HB1MODE[1:0] = 11 and CPEN=1 ¹⁾ 0 _B LOW, VSH1 = Low : VS - VSH1 > V _{HS1VDSTHx} 1 _B HIGH, VSH1 = High: VS - VSH1 ≤ V _{HS1VDSTHx}
PWM6STAT	5	r	PWM6 status 0 _B LOW, PWM6 is Low 1 _B HIGH, PWM6 is High
PWM5STAT	4	r	PWM5 status 0 _B LOW, PWM5 is Low 1 _B HIGH, PWM5 is High
PWM4STAT	3	r	PWM4 Status 0 _B LOW, PWM4 is Low 1 _B HIGH, PWM4 is High
PWM3STAT	2	r	PWM3 status 0 _B LOW, PWM3 is Low 1 _B HIGH, PWM3 is High
PWM2STAT	1	r	PWM2 Status 0 _B LOW, PWM2 is Low 1 _B HIGH, PWM2 is High
PWM1STAT	0	r	PWM1/CRC status 0 _B LOW, PWM1/CRC is Low 1 _B HIGH, PWM1/CRC is High

1) HBxVOUT = 0 if (CPEN=1 and HBxMODE ≠ 11) or CPEN=0.

Serial Peripheral Interface

Table 76 Reset of GEN_STAT

Register Reset Type	Reset Values	Reset Short Name	Reset Mode	Note
POR/Soft reset	0000 0000 0000 0000 _B			
Restart	0000 0000 xx00 000x _B			

Serial Peripheral Interface

Turn-on/off delay regulation register

TDREG

Turn-on/off delay regulation register

(101 0001_B)

Reset Value: see [Table 77](#)

15	14	13	12	11	10	9	8	7	6	5	4	3	2	1	0
RES				RES	IPDCH G3_ST	IPDCH G2_ST	IPDCH G1_ST	RES	IPCHG 3_ST	IPCHG 2_ST	IPCHG 1_ST	RES	TDRE G3	TDRE G2	TDRE G1
r				r	r	r	r	r	r	r	r	r	r	r	r

Field	Bits	Type	Description
RES	15:12	r	Reserved, always reads as 0
RES	11	r	Reserved, always reads as 0
IPDCHG3_ST	10	r	HB3 predischage status 0 _B CLAMP , the predischage current is equal to 0.5 mA typ. or ICHGMAX3 if AGC[1:0] = 10 _B or 11 _B , and HB3_PWM_EN = 1 ¹⁾ 1 _B NO_CLAMP , 0.5 mA < predischage current < ICHGMAX3 ¹⁾
IPDCHG2_ST	9	r	HB2 predischage status 0 _B CLAMP , the predischage current is equal to 0.5 mA typ. or ICHGMAX2 if AGC[1:0] = 10 _B or 11 _B , and HB2_PWM_EN = 1 ¹⁾ 1 _B NO_CLAMP , 0.5 mA < predischage current < ICHGMAX2 ¹⁾
IPDCHG1_ST	8	r	HB1 predischage status 0 _B CLAMP , the predischage current is equal to the 0.5 mA typ. or ICHGMAX1 if AGC[1:0] = 10 _B or 11 _B , and HBx_PWM_EN = 1 ¹⁾ 1 _B NO_CLAMP , 0.5 mA < predischage current < ICHGMAX1 ¹⁾
RES	7	r	Reserved, always reads as 0
IPCHG3_ST	6	r	HB3 precharge status 0 _B CLAMP , the precharge current is equal to 0.5 mA typ. or ICHGMAX3 if AGC[1:0] = 10 _B or 11 _B , and HB3_PWM_EN = 1 ¹⁾ 1 _B NO_CLAMP , 0.5 mA < precharge current < ICHGMAX3 ¹⁾
IPCHG2_ST	5	r	HB2 precharge status 0 _B CLAMP , the precharge current is equal to 0.5 mA typ. or ICHGMAX2 if AGC[1:0] = 10 _B or 11 _B , and HB2_PWM_EN = 1 ¹⁾ 1 _B NO_CLAMP , 0.5 mA < precharge current < ICHGMAX2 ¹⁾

Serial Peripheral Interface

Field	Bits	Type	Description
IPCHG1_ST	4	r	HB1 precharge status 0_B CLAMP , the precharge current is equal to the 0.5 mA typ. or ICHGMAX1 if AGC[1:0] = 10_B or 11_B , and HB1_PWM_EN = $1^{1)}$ 1_B NO_CLAMP , 0.5 mA < precharge current < ICHGMAX1 ¹⁾
RES	3	r	Reserved, always reads as 0
TDREG3	2	r	HB3 Regulation of turn-on/off delay 0_B NO_REG , tDON3 and tDOFF3 are not in regulation 1_B REG , tDON3 and/or tDOFF3 are in regulation
TDREG2	1	r	HB2 Regulation of turn-on/off delay 0_B NO_REG , tDON2 and tDOFF2 are not in regulation 1_B REG , tDON2 and/or tDOFF2 are in regulation
TDREG1	0	r	HB1 Regulation of turn-on/off delay 0_B NO_REG , tDON and tDOFF are not in regulation 1_B REG , tDON and/or tDOFF are in regulation

1) IPCHGx_ST = 1 otherwise (PWM disabled, HB in high impedance or AGC[1:0] = 00_B or 01_B).

Table 77 Reset of **TDREG**

Register Reset Type	Reset Values	Reset Short Name	Reset Mode	Note
POR/Soft reset	0000 0000 0000 0000 _B			
Restart	0000 0000 xx00 000x _B			

Serial Peripheral Interface

Drain-source overvoltage status

DSOV

Drain-source overvoltage

(101 0010_B)

Reset Value: see [Table 78](#)

15	14	13	12	11	10	9	8	7	6	5	4	3	2	1	0
RES	OC_CSA	VSINTOVBRAKE_ST	VSOVBRAKE_ST	RES	LS3DSOV_BRK	LS2DSOV_BRK	LS1DSOV_BRK	RES	RES	LS3DSOV	HS3DSOV	LS2DSOV	HS2DSOV	LS1DSOV	HS1DSOV
r	rc	rc	rc	r	rc	rc	rc	r	r	rc	rc	rc	rc	rc	rc

Field	Bits	Type	Description
RES	15	r	Reserved, always reads as 0
OC_CSA	14	rc	CSA Overcurrent detection 0 _B NO_OC , No overcurrent detected 1 _B OC , Overcurrent detected
VSINTOVBRAKE_ST	13	rc	VSINT Brake status 0 _B NOT_DETECT , VSINT overvoltage brake condition is not detected 1 _B DETECT , VSINT overvoltage brake conditions is detected
VSOVBRAKE_ST	12	rc	VS Brake status 0 _B NOT_DETECT , VS overvoltage brake conditions is not detected 1 _B DETECT , VS overvoltage brake conditions is detected
RES	11	r	Reserved, always reads as 0
LS3DSOV_BRK	10	rc	Drain-source overvoltage on low-side 3 during braking 0 _B NO_OV , No drain-source overvoltage on LS3 1 _B OV , Drain-source overvoltage on LS3
LS2DSOV_BRK	9	rc	Drain-source overvoltage on low-side 2 during braking 0 _B NO_OV , No drain-source overvoltage on LS2 1 _B OV , Drain-source overvoltage on LS2
LS1DSOV_BRK	8	rc	Drain-source overvoltage on low-side 1 during braking 0 _B NO_OV , No drain-source overvoltage on LS1 1 _B OV , Drain-source overvoltage on LS1
RES	7	r	Reserved, always reads as 0
RES	6	r	Reserved, always reads as 0
LS3DSOV	5	rc	Drain-source overvoltage on low-side 3 0 _B NO_OV , No drain-source overvoltage on LS3 1 _B OV , Drain-source overvoltage on LS3

Serial Peripheral Interface

Field	Bits	Type	Description
HS3DSOV	4	rc	Drain-source overvoltage on high-side 3 0 _B NO_OV , No drain-source overvoltage on HS3 1 _B OV , Drain-source overvoltage on HS3
LS2DSOV	3	rc	Drain-source overvoltage on low-side 2 0 _B NO_OV , No drain-source overvoltage on LS2 1 _B OV , Drain-source overvoltage on LS2
HS2DSOV	2	rc	Drain-source overvoltage on high-side 2 0 _B NO_OV , No drain-source overvoltage on HS2 1 _B OV , Drain-source overvoltage on HS2
LS1DSOV	1	rc	Drain-source overvoltage on low-side 1 0 _B NO_OV , No drain-source overvoltage on LS1 1 _B OV , Drain-source overvoltage on LS1
HS1DSOV	0	rc	Drain-source overvoltage on high-side 1 0 _B NO_OV , No drain-source overvoltage on HS1 1 _B OV , Drain-source overvoltage on HS1

Table 78 Reset of **DSOV**

Register Reset Type	Reset Values	Reset Short Name	Reset Mode	Note
POR/Soft reset	0000 0000 0000 0000 _B			
Restart	0xxx 0xxx 00xx xxxx _B			

Serial Peripheral Interface

Effective MOSFET turn.on/off delay - PWM half-bridge 1

EFF_TDON_OFF1

Effective MOSFET turn.on/off delay - HB1 (101 0011_B)

Reset Value: see [Table 79](#)

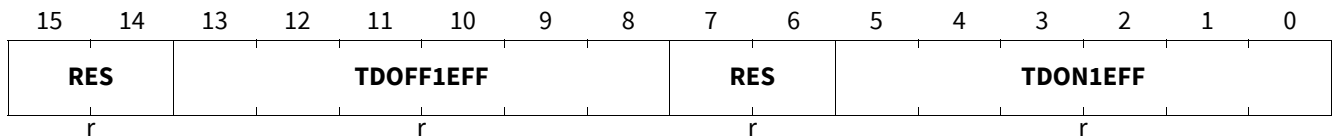

Field	Bits	Type	Description
RES	15:14	r	Reserved, always reads as 0
TDOFF1EFF	13:8	r	Effective active MOSFET turn-off delay HB1 Nominal effective tDOFF1 = 53.3 ns x TDOFF1EFF[13:8] _D
RES	7:6	r	Reserved, always reads as 0
TDON1EFF	5:0	r	Effective active MOSFET turn-on delay HB1 Nominal effective tDON1 = 53.3 ns x TDON1EFF[5:0] _D

Table 79 Reset of [EFF_TDON_OFF1](#)

Register Reset Type	Reset Values	Reset Short Name	Reset Mode	Note
POR/Soft reset	0000 0000 0000 0000 _B			
Restart	00xx xxxx 00xx xxxx _B			

Serial Peripheral Interface

Effective MOSFET turn.on/off delay - PWM half-bridge 2

EFF_TDON_OFF2

Effective MOSFET turn.on/off delay - HB 2 (101 0100_B)

Reset Value: see [Table 80](#)

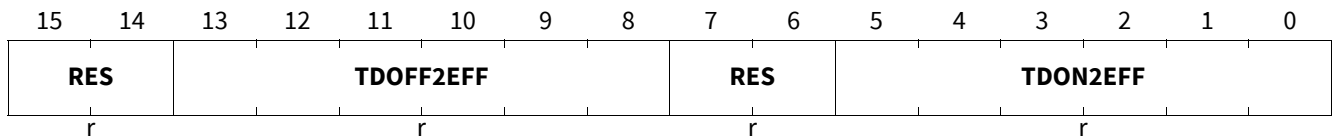

Field	Bits	Type	Description
RES	15:14	r	Reserved, always reads as 0
TDOFF2EFF	13:8	r	Effective active MOSFET turn-off delay HB2 Nominal effective tDOFF2 = 53.3 ns x TDOFF2EFF[13:8] _D
RES	7:6	r	Reserved, always reads as 0
TDON2EFF	5:0	r	Effective active MOSFET turn-on delay HB2 Nominal effective tDON2 = 53.3 ns x TDON2EFF[5:0] _D

Table 80 Reset of [EFF_TDON_OFF2](#)

Register Reset Type	Reset Values	Reset Short Name	Reset Mode	Note
POR/Soft reset	0000 0000 0000 0000 _B			
Restart	00xx xxxx 00xx xxxx _B			

Serial Peripheral Interface

Effective MOSFET turn.on/off delay - PWM half-bridge 3

EFF_TDON_OFF3

Effective MOSFET turn.on/off delay - HB3 (101 0101_B)

Reset Value: see [Table 81](#)

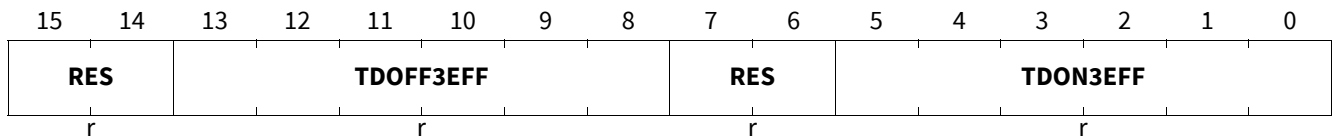

Field	Bits	Type	Description
RES	15:14	r	Reserved, always reads as 0
TDOFF3EFF	13:8	r	Effective active MOSFET turn-off delay HB3 Nominal effective tDOFF3 = 53.3 ns x TDO3EFF[13:8] _D
RES	7:6	r	Reserved, always reads as 0
TDON3EFF	5:0	r	Effective active MOSFET turn-on delay HB3 Nominal effective tDON3 = 53.3 ns x TDON3EFF[5:0] _D

Table 81 Reset of [EFF_TDON_OFF3](#)

Register Reset Type	Reset Values	Reset Short Name	Reset Mode	Note
POR/Soft reset	0000 0000 0000 0000 _B			
Restart	00xx xxxx 00xx xxxx _B			

Serial Peripheral Interface

MOSFET rise/fall time - PWM half-bridge 1

TRISE_FALL1

MOSFET rise/fall time - HB1

(101 0111_B)

Reset Value: see [Table 82](#)

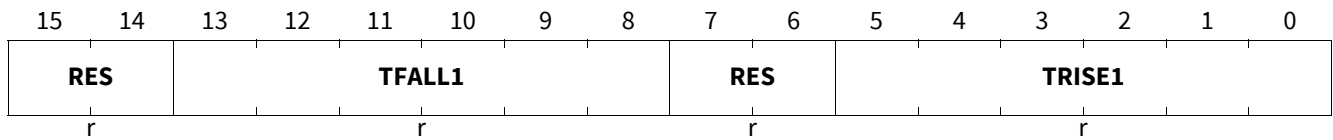

Field	Bits	Type	Description
RES	15:14	r	Reserved, always reads as 0
TFALL1	13:8	r	Active MOSFET fall time HB1 Nominal tFALL1 = 53.3 ns x TFALL1[5:0] _D
RES	7:6	r	Reserved, always reads as 0
TRISE1	5:0	r	Active MOSFET rise time HB1 Nominal tRISE1 = 53.3 ns x TRISE1[5:0] _D

Table 82 Reset of [TRISE_FALL1](#)

Register Reset Type	Reset Values	Reset Short Name	Reset Mode	Note
POR/Soft reset	0000 0000 0000 0000 _B			
Restart	00xx xxxx 00xx xxxx _B			

Serial Peripheral Interface

MOSFET rise/fall time - PWM half-bridge 2

TRISE_FALL2

MOSFET rise/fall time - HB2

(101 1000_B)

Reset Value: see [Table 83](#)

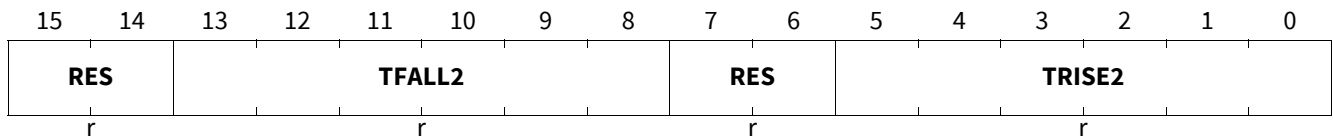

Field	Bits	Type	Description
RES	15:14	r	Reserved, always reads as 0
TFALL2	13:8	r	Active MOSFET fall time HB2 Nominal tFALL2 = 53.3 ns x TFALL2[5:0] _D
RES	7:6	r	Reserved, always reads as 0
TRISE2	5:0	r	Active MOSFET rise time HB2 Nominal tRISE2 = 53.3 ns x TRISE2[5:0] _D

Table 83 Reset of [TRISE_FALL2](#)

Register Reset Type	Reset Values	Reset Short Name	Reset Mode	Note
POR/Soft reset	0000 0000 0000 0000 _B			
Restart	00xx xxxx 00xx xxxx _B			

Serial Peripheral Interface

MOSFET rise/fall time - PWM half-bridge 3

TRISE_FALL3

MOSFET rise/fall time - HB3

(101 1001_B)

Reset Value: see [Table 84](#)

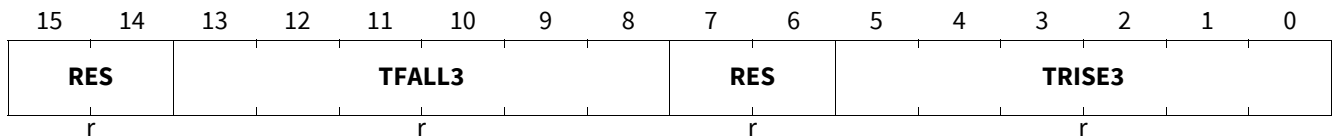

Field	Bits	Type	Description
RES	15:14	r	Reserved, always reads as 0
TFALL3	13:8	r	Active MOSFET fall time HB3 Nominal tFALL3 = 53.3 ns x TFALL3[5:0] _D
RES	7:6	r	Reserved, always reads as 0
TRISE3	5:0	r	Active MOSFET rise time HB3 Nominal tRISE3 = 53.3 ns x TRISE3[5:0] _D

Table 84 Reset of [TRISE_FALL3](#)

Register Reset Type	Reset Values	Reset Short Name	Reset Mode	Note
POR/Soft reset	0000 0000 0000 0000 _B			
Restart	00xx xxxx 00xx xxxx _B			

13.6.3 Family and product information register

Family and Product Identification Register

FAM_PROD_STAT

Family and Product Identification Register (111 0000_B)

Reset Value: see [Table 85](#)

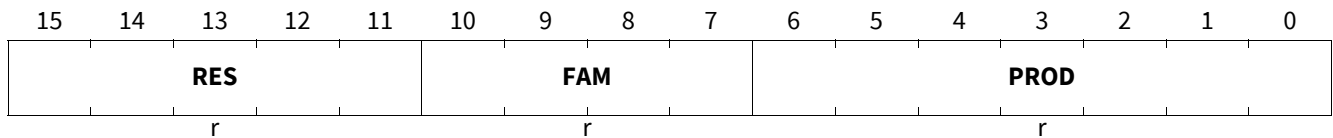

Field	Bits	Type	Description
RES	15:11	r	Reserved, always reads as 0
FAM	10:7	r	Device Family Identifier 1000 _B , BLDC Motor System IC
PROD	6:0	r	Device Product Identifier 000 0000 _B TLE9562-3QX/QX , TLE9562-3QX/-3QXJ/QX 000 0001 _B TLE9561-3QX/QX , TLE9561-3QX/-3QXJ/QX 000 0010 _B TLE9563-3QX , TLE9563-3QX/-3QXJ 000 0011 _B TLE9564QX , TLE9564QX, TLE9185QX 001 0000 _B TLE9562-3QX V33 , TLE9562-3QX V33 001 0010 _B TLE9563-3QX V33 , TLE9563-3QX V33 001 0011 _B TLE9564QX V33 , TLE9564QX V33, TLE9185QX V33 001 1000 _B TLE9560QX , TLE9560-3QX/-3QXJ

Table 85 Reset of **FAM_PROD_STAT**

Register Reset Type	Reset Values	Reset Short Name	Reset Mode	Note
POR/Soft reset	0000 0100 0000 0011 _B			
Restart	0000 0100 0000 0011 _B			

13.7 Electrical Characteristics

Table 86 Electrical Characteristics: Power Stage

$V_{SINT} = 5.5\text{ V to } 28\text{ V}$, $T_j = -40^\circ\text{C to } +150^\circ\text{C}$, all voltages with respect to ground, positive current flowing into pin (unless otherwise specified)

Parameter	Symbol	Values			Unit	Note or Test Condition	Number
		Min.	Typ.	Max.			
SPI frequency							
Maximum SPI frequency	$f_{SPI,max}$	–	–	6.0	MHz	¹⁾ $V_{CC1} > 3\text{ V}$	P_14.7.1
SPI Interface; Logic Inputs SDI, CLK and CSN							
H-input Voltage Threshold	V_{IH}	–	–	$0.7 \times V_{CC1}$	V	–	P_14.7.2
L-input Voltage Threshold	V_{IL}	$0.3 \times V_{CC1}$	–	–	V	–	P_14.7.3
Hysteresis of input Voltage	V_{IHY}	–	$0.12 \times V_{CC1}$	–	V	¹⁾	P_14.7.4
Pull-up Resistance at pin CSN	R_{ICSN}	20	40	80	k Ω	–	P_14.7.5
Pull-down Resistance at pin SDI and CLK	$R_{ICLK/SDI}$	20	40	80	k Ω	$V_{SDI/CLK} = 0.2 \times V_{CC1}$	P_14.7.6
Input Capacitance at pin CSN, SDI or CLK	C_I	–	10	–	pF	¹⁾ $V_{CSN}, V_{SDI}, V_{CLK} = V_{CC1}$	P_14.7.7
Logic Output SDO							
H-output Voltage Level	V_{SDOH}	$0.8 \times V_{CC1}$	–	–	V	$I_{DOH} = -2\text{ mA}$	P_14.7.8
L-output Voltage Level	V_{SDOL}	–	–	$0.2 \times V_{CC1}$	V	$I_{DOL} = 2\text{ mA}$	P_14.7.9
‘Tri-state Input Capacitance	C_{SDO}	–	10	15	pF	¹⁾ $V_{CSN}, V_{SDI}, V_{CLK} = V_{CC1}$	P_14.7.11
Tri-state Leakage Current	I_{SDOLK}	–10	–	10	μA	¹⁾ $V_{CSN} = V_{CC1}$, $0\text{V} < V_{SDO} < V_{CC1}$	P_14.7.38
Data Input Timing¹⁾							
Clock Period	t_{pCLK}	160	–	–	ns	–	P_14.7.12
Clock HIGH Time	t_{CLKH}	70	–	–	ns	–	P_14.7.13
Clock LOW Time	t_{CLKL}	70	–	–	ns	–	P_14.7.14
Clock LOW before CSN LOW	t_{bef}	70	–	–	ns	–	P_14.7.15
CSN Setup Time	t_{lead}	160	–	–	ns	–	P_14.7.16
CLK Setup Time	t_{lag}	160	–	–	ns	–	P_14.7.17
Clock LOW after CSN HIGH	t_{beh}	70	–	–	ns	–	P_14.7.18
SDI Setup Time	t_{DISU}	60	–	–	ns	–	P_14.7.19
SDI Hold Time	t_{DIHO}	40	–	–	ns	–	P_14.7.20

Serial Peripheral Interface

Table 86 Electrical Characteristics: Power Stage (cont'd)

$V_{SINT} = 5.5\text{ V to }28\text{ V}$, $T_j = -40^\circ\text{C to }+150^\circ\text{C}$, all voltages with respect to ground, positive current flowing into pin (unless otherwise specified)

Parameter	Symbol	Values			Unit	Note or Test Condition	Number
		Min.	Typ.	Max.			
Input Signal Rise Time at pin SDI, CLK and CSN	t_{rIN}	-	-	20	ns	-	P_14.7.21
Input Signal Fall Time at pin SDI, CLK and CSN	t_{fIN}	-	-	20	ns	-	P_14.7.22
Delay Time for Mode Changes ²⁾	$t_{Del,Mode}$	-	-	5	μs	³⁾	P_14.7.23
CSN HIGH Time	$t_{CSN(high)}$	3	-	-	μs	-	P_14.7.24

Data Output Timing¹⁾

SDO Rise Time	t_{rSDO}	-	30	40	ns	$C_L = 50\text{ pF}$, $0.2 \times V_{CC1}$ to $0.8 \times V_{CC1}$	P_14.7.25
SDO Fall Time	t_{fSDO}	-	30	40	ns	$C_L = 50\text{ pF}$, $0.8 \times V_{CC1}$ to $0.2 \times V_{CC1}$	P_14.7.26
SDO Enable Time	t_{ENSDO}	-	-	40	ns	LOW impedance	P_14.7.27
SDO Disable Time	t_{DISSDO}	-	-	40	ns	HIGH impedance	P_14.7.28
SDO Valid Time	t_{VASDO}	-	-	40	ns	$C_L = 50\text{ pF}$	P_14.7.29

- 1) Not subject to production test; specified by design.
- 2) Applies to all mode changes triggered via SPI commands.
- 3) Guaranteed by design.

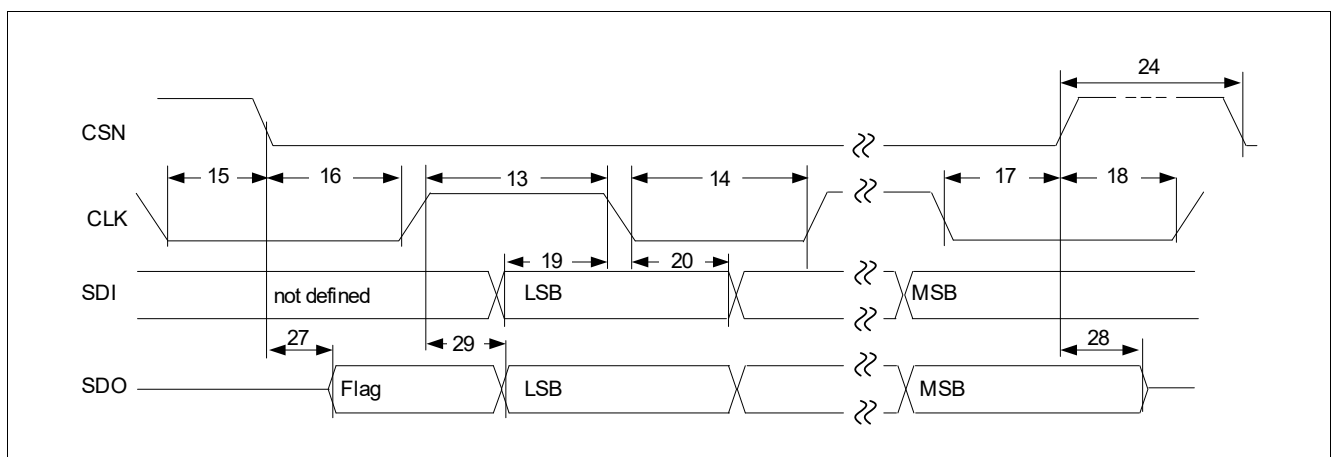

Figure 74 SPI Timing Diagram

Note: Numbers in drawing correlate with the last 2 digits of the Number field in the Electrical Characteristics table.

Application Information

14 Application Information

Note: The following information is given as a hint for the implementation of the device only and shall not be regarded as a description or warranty of a certain functionality, condition or quality of the device.

14.1 Application Diagrams

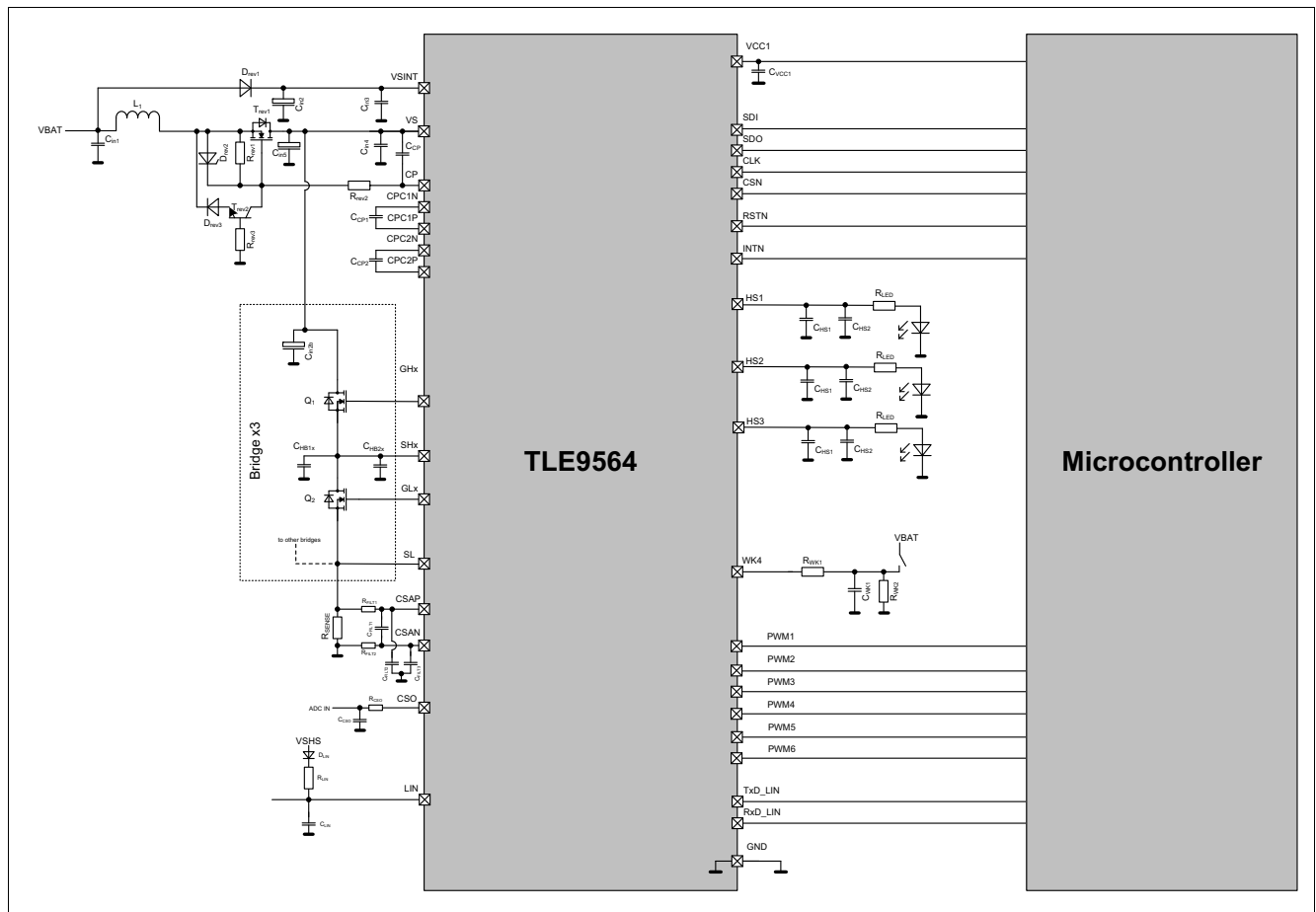

Figure 75 TLE9564QX Application Diagram

Note: This is a very simplified example of an application circuit. The function must be always verified in the real application.

Application Information

Table 87 Bill of Material

Ref.	Typical Value	Purpose / Comment
Capacitances		
C _{in1}	100 nF ±20% ceramic	Input filter battery capacitor for optimum EMC behavior
C _{in2}	100 µF ±20%, 50 V Electrolytic	Buffering capacitor to cut off battery spikes, depending on the application
C _{in2b}	470 µF ±20%, 50 V Electrolytic	Buffering capacitor for bridges. Cut off battery spikes, depending on the application
C _{in3}	100 nF ±20%, 50 V Ceramic	Input capacitor
C _{in4}	100 nF ±20%, 50 V Ceramic	Input capacitor
C _{in5}	470 µF ±20%, 50 V Electrolytic	Buffering capacitor for bridges. Cut off battery spikes, depending on the application
C _{CP}	470 nF ±20%, 50 V Ceramic	Charge-Pump buffering capacitor
C _{CP1} / C _{CP2}	220 nF ±20%, 50 V Ceramic	Charge-Pump flying capacitor to be placed as closed as possible to the device pins, in order to minimize the length of the PCB tracks
C _{FILT1}	1.5 nF ±20%, 16 V Ceramic	Current-sense filtering
C _{FILT2} / C _{FILT3}	22 nF ±20%, 16 V Ceramic	Current-sense filtering
C _{CSO}	16 V Ceramic	CSO buffering cap for a stable ADC voltage. Max 400 pF in case no resistor is used. With 50 Ω resistor up to 2.2 nF. (See CSA configuration register)
C _{LIN}	1 nF / OEM dependent	LIN master termination
C _{VCC1}	2.2 µF ±20%, 16 V	Blocking capacitor. Low ESR. Minimum 1 µF effective capacitance
C _{HB1x}	10 nF ±20%, 50 V Ceramic	Half-Bridge EME (electromagnetic emission) and ESD suppression filter to be placed close to the connector. Other capacitance values might be needed depending on application
C _{HB2x}	560 pF ±20%, 50 V Ceramic	Optional filter for EMI immunity to be placed close to the SHx pin (PCB footprints highly recommended). Other capacitance values might be needed depending on application
C _{HS1}	47 pF / OEM dependent	Only required om case of off-board connection to optimize EMC behavior, place close to pin
C _{HS2}	33 nF / OEM dependent	As required by application, mandatory protection for off-board connection
C _{WK1} / C _{WK2}	47 nF / OEM dependent	Spike filtering, as required by application, mandatory protection for off-board connections

Application Information

Table 87 Bill of Material (cont'd)

Ref.	Typical Value	Purpose / Comment
Inductances		
L ₁	4 uH ... 6 uH	Input filter for power stage - consider high current rating (application dependent)
Resistances		
R _{REV1}	100 kΩ ±5%	Other values needed depending on application
R _{REV2}	10 kΩ ±5%	Device protection against reverse battery
R _{REV3}	10 kΩ ±5%	
R _{SENSE}	5 mΩ ±1%	Current-sense resistor
R _{FILT1} / R _{FILT2}	4.7 Ω ±5%	Current-sense filtering
R _{CSO}	50 Ω ±5%	Compensation for internal opamp. Depending on SPI configuration
R _{LIN}	1 k ±5%	LIN master termination
R _{LED}	1 k	Limit LED-current
R _{WK1} / R _{WK2} / R _{WK3} / R _{WK4}	10 kΩ ±5%	
Active Components		
D _{REV1}	RR268MM600	Reverse polarity protection
D _{REV2}	BZX84C16	Gate protection. Limit V _{GS}
D _{REV3}	BAS21	
T _{REV1}	IPZ40N04S5L-2R8	Reverse battery protection, N-MOS
T _{REV2}	BC846	
Q ₁ / Q ₂	IPZ40N04S5-3R1	Main power switches
D _{LIN}	BAS70	Requested by LIN standard; reverse polarity protection of network

Application Information

14.2 ESD Tests

14.2.1 ESD according to IEC61000-4-2

Tests for ESD robustness according to IEC61000-4-2 “GUN test” (150 pF, 330 Ω) have been performed. The results and test condition are available in a test report. The values for the test are listed below.

Table 88 ESD “GUN test”¹⁾²⁾

Performed Test	Result	Unit	Remarks
ESD at pin LIN, HSx, VS, VSINT, VS, WKx versus GND	> 6	kV	positive pulse
ESD at pin LIN, HSx, VS, VSINT, VS, WKx versus GND	< -6	kV	negative pulse

- 1) ESD susceptibility “ESD GUN” according to EMC 1.3 Test specification, Section 4.3 (IEC 61000-4-2). Tested by external test house (IBEE Zwickau, EMC Test report Nr. 20.12.20).
- 2) ESD Test “Gun Test” is specified with external components for pins VS, VSINT, VS, WKx, HSx. See the application diagram in [Chapter 14.1](#) for more information.

14.2.2 ESD according to SAE J2962

Tests for ESD robustness according to SAE J2962 have been performed.

Table 89 ESD according to SAE J2962

Performed Test	Result	Unit	Remarks
ESD at pin	± 4	kV	Unpowered, contact discharge
ESD at pin	± 8	kV	¹⁾ Powered, contact discharge
ESD at pin	± 25	kV	¹⁾ Powered, air discharge

- 1) For ESD pulses ≤ - 6 kV, VCC1 undervoltage may be detected.

14.3 Thermal Behavior of Package

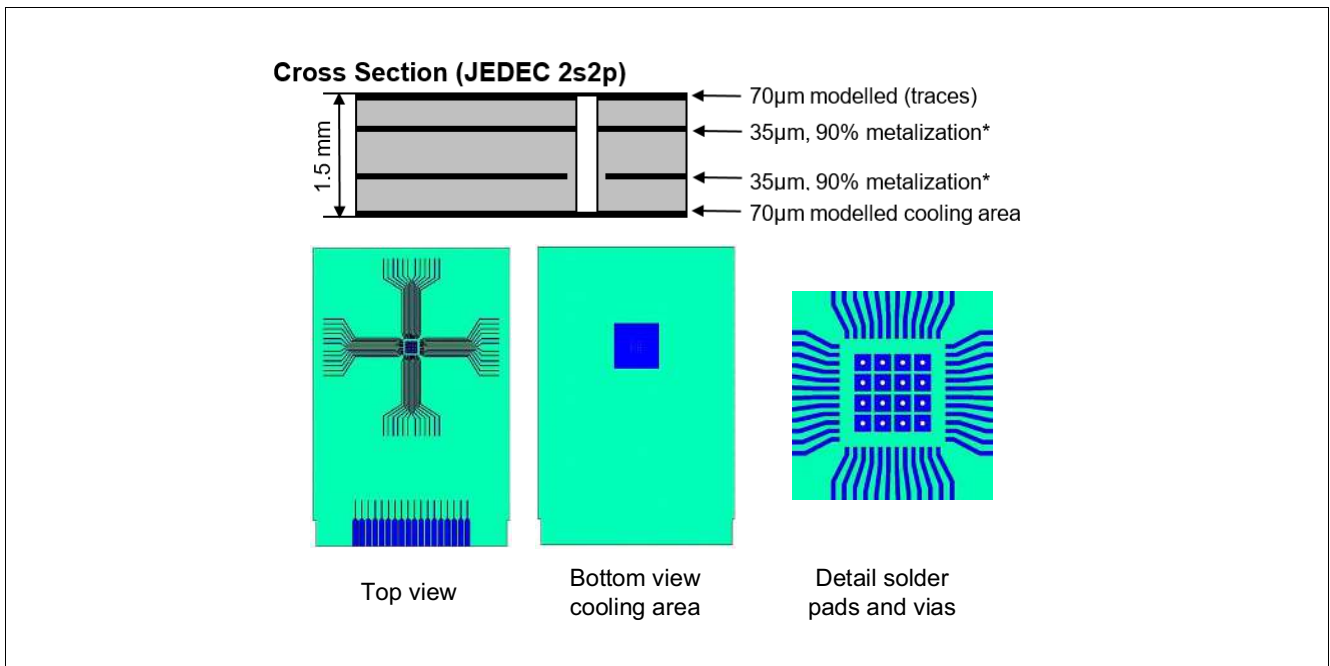

Figure 76 Board Setup

Board setup is defined according JESD 51-2, -5, -7.

Board: $76.2 \times 114.3 \times 1.5 \text{ mm}^3$ with 2 inner copper layers (35 μm thick), with thermal via array under the exposed pad contacting the first inner copper layer and 300 mm² cooling area on the bottom layer (70 μm).

14.4 Further Application Information

- The VS pin supplies the bridge driver and the charge pump, and is the sense pin for the high-side MOSFETs drain voltage. It is therefore highly recommended to connect a 100 nF / 50V ceramic by-pass capacitor as close as possible to the VS pin with a short PCB trace to GND.
- Please contact us for information regarding the FMEA pin
- For further information you may contact <http://www.infineon.com/>

15 Package Outlines

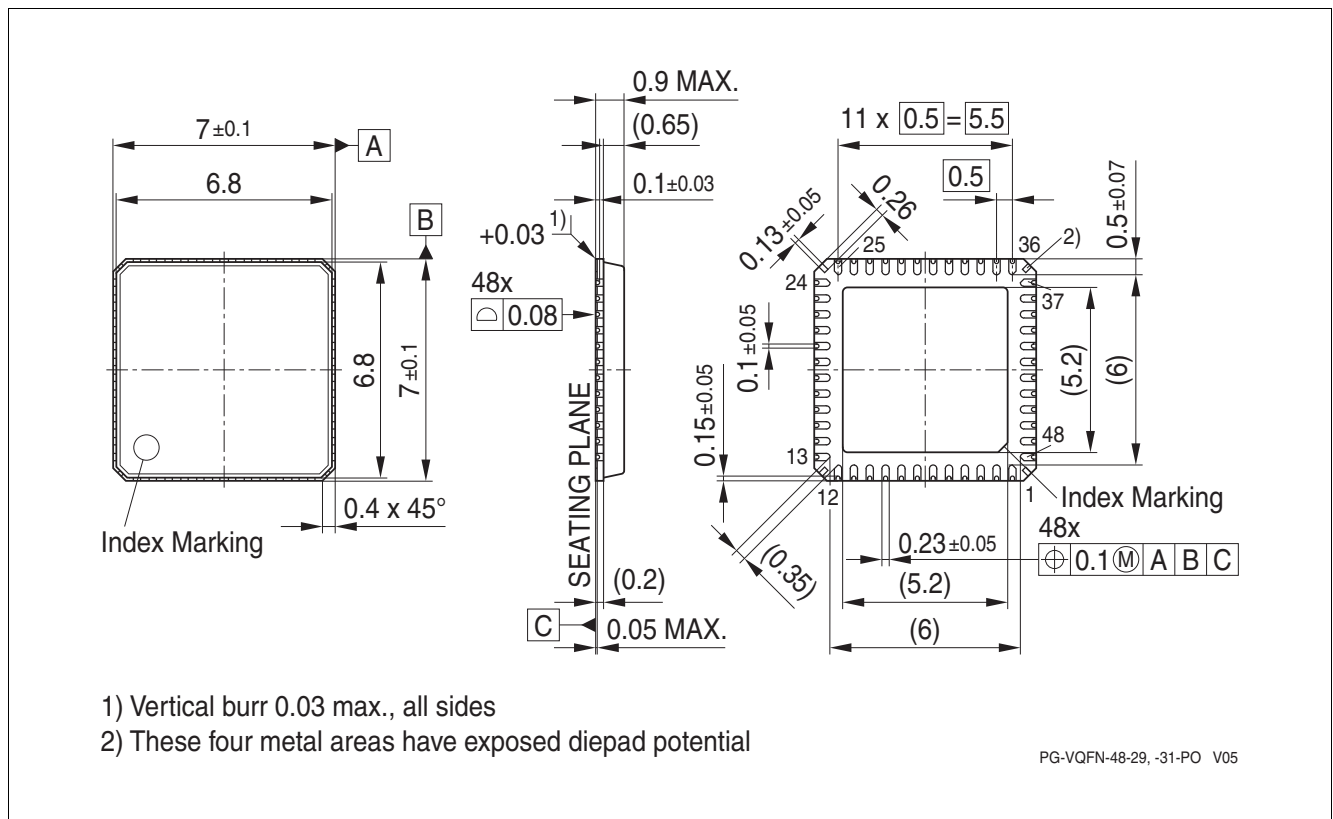

Figure 77 PG-VQFN-48¹⁾

Green Product (RoHS compliant)

To meet the world-wide customer requirements for environmentally friendly products and to be compliant with government regulations the device is available as a green product. Green products are RoHS-Compliant (i.e Pb-free finish on leads and suitable for Pb-free soldering according to IPC/JEDEC J-STD-020).

Further information on packages

<https://www.infineon.com/packages>

1) Dimensions in mm

Revision History

16 Revision History

Revision	Date	Changes
1.0	2021-01-21	First release

Trademarks

All referenced product or service names and trademarks are the property of their respective owners.

Edition 2021-01-21

Published by

Infineon Technologies AG

81726 Munich, Germany

© 2021 Infineon Technologies AG.

All Rights Reserved.

Do you have a question about any aspect of this document?

Email: erratum@infineon.com

IMPORTANT NOTICE

The information given in this document shall in no event be regarded as a guarantee of conditions or characteristics ("Beschaffenhheitsgarantie").

With respect to any examples, hints or any typical values stated herein and/or any information regarding the application of the product, Infineon Technologies hereby disclaims any and all warranties and liabilities of any kind, including without limitation warranties of non-infringement of intellectual property rights of any third party.

In addition, any information given in this document is subject to customer's compliance with its obligations stated in this document and any applicable legal requirements, norms and standards concerning customer's products and any use of the product of Infineon Technologies in customer's applications.

The data contained in this document is exclusively intended for technically trained staff. It is the responsibility of customer's technical departments to evaluate the suitability of the product for the intended application and the completeness of the product information given in this document with respect to such application.

For further information on technology, delivery terms and conditions and prices, please contact the nearest Infineon Technologies Office (www.infineon.com).

WARNINGS

Due to technical requirements products may contain dangerous substances. For information on the types in question please contact your nearest Infineon Technologies office.

Except as otherwise explicitly approved by Infineon Technologies in a written document signed by authorized representatives of Infineon Technologies, Infineon Technologies' products may not be used in any applications where a failure of the product or any consequences of the use thereof can reasonably be expected to result in personal injury.