

PART NUMBER	REVISION	DESCRIPTION	FEED TYPE
2150156-2	E	FINE CRIMP HEIGHT ADJUST	PNEUMATIC
7-2150156-2	E	PNEUMATIC AND CRIMP TOOLING KIT	PNEUMATIC
7-2150156-7	A	CRIMP TOOLING KIT	-

ATLANTIC VERSION TERMINATOR INTERFACE ADAPTER

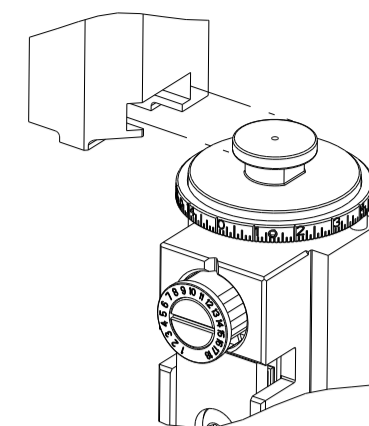

APPLICATOR DATA		
CRIMP	SIZE	TYPE
WIRE	3.30 mm [.130]	F
INSUL	3.94 mm [.155]	OV
APPL INSTRUCTIONS 408-35043		

TERMINAL DATA: TE TERMINAL TE CRIMP SPECIFICATION			
TERMINAL NAME: RING TONGUE			
WIRE STRIP LENGTH		INSULATION DIAMETER RANGE	
5.50-5.80 mm [.217-.228 IN]		∅2.20-3.00 mm [.087-.118 IN]	
TERMINAL APPLICATION SPECIFICATION	114-18022	-	-
TERMINALS APPLIED			
TE TERMINAL	TE TERMINAL	TE TERMINAL	TE TERMINAL
346101-2			

WIRE SIZE	CRIMP HEIGHT mm [INCH]	CRIMP HEIGHT REFERENCE SETTING
2.50mm2	2.40 +/- 0.05 [.094 +/- .002]	4.3
2.00mm2	2.28 +/- 0.05 [.090 +/- .002]	5.5
1.50mm2	2.16 +/- 0.05 [.085 +/- .002]	6.6

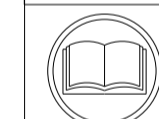

- 1 RECOMMENDED SPARE PARTS
- 2 REFER TO SUPPLIED INSTRUCTION SHEET FOR CLEANING, LUBRICATION AND STORAGE OF APPLICATOR.
- 3 APPLY PART NUMBER 1-23419-5 LOCTITE TO THREADS OF ITEM 50. APPLY PART NUMBER 2-23419-6 LOCTITE TO THREADS OF ITEM 242.
- 4 CRIMP HEIGHT REFERENCE SETTING WAS THE SETTING USED WHEN THE APPLICATOR WAS QUALIFIED AT THE FACTORY. ADJUSTMENT MAY BE NECESSARY WHEN RUNNING APPLICATOR IN THE FIELD.
- 5 TERMINAL PITCH NOT COMPATIBLE WITH MECHANICAL FEED.
- 6. UNLESS SPECIFIED OTHERWISE TORQUE VALUES SHALL BE USED PER DOCUMENT, 101-35000.

**\*WARNING**  
ON INSTALLATION, SET WIRE DISC TO CRIMP HEIGHT REFERENCE SETTING FOR LARGEST WIRE SIZE. CRIMP HEIGHT REFERENCE SETTINGS GREATER THAN THE VALUE SHOWN MAY CAUSE DAMAGE TO THE CRIMP TOOLING, REFER TO THE INSTRUCTION SHEET FOR PROPER SETUP AND ADJUSTMENTS.

**ATLANTIC VERSION**  
Shown on sheets 1 of 4 & 2 of 4  
(Pacific version shown on sheets 3 of 4 & 4 of 4)

LOC	DIST	REVISIONS					
A	66	P	LTN	DESCRIPTION	DATE	OWN	APVD
		B		ECR-13-005521	28MAR2013	RK	TE
		C		ECR-19-006354	18APR2019	LG	TE
		D		ECR-21-118540	25OC12021	JWC	TE
		E		ECR-22-146803	20JUL2022	FJ	TE

-	1	1	2119641-1	FEED CAM, AIR FEED	248	
-	1	1	2119082-9	CAM, SNAIL, INSULATION ADJUSTMENT	244	
-	1	1	2079764-1	WASHER, WAVE SPRING, CREST-TO-CREST	243	
-	1	1	2119083-1	RETAINER, INSULATION DIAL	242	
-	1	1	2844940-4	AIR FEED MODULE	238	
-	1	1	1-18028-0	WASHER, FLAT, REG M8	192	
-	1	1	6-993111-6	PIN, SLOTTED SPRING 3.0 X 14.0	177	
-	1	1	8-22280-7	SPRING, COMPRESSION	176	
-	1	1	1752353-2	GUIDE PIN,HOLDDOWN	175	
-	1	1	1901680-2	GUIDE PIN,HOLDDOWN	174	
-	REF	REF	994970-2	COUNTER, MAGNETIC	164	
-	1	1	455888-6	SPACER, CRIMPER	82	
-	1	1	455888-2	SPACER, CRIMPER	75	
-	1	1	2119791-9	DEPRESSOR, WIRE	73	
-	1	1	1803607-4	DOCUMENTATION PACKAGE	71	
-	2	2	2-18032-2	SCR, SET, FLT PNT, M3 X 10.0	70	
-	1	1	2119943-1	WASHER, SPACER	69	
-	1	1	2119740-1	TAG, IDENTIFICATION	67	
-	2	2	2168078-1	SCREW, DRIVE, RH, RoHS, 2 x .188	66	
-	1	1	1901681-5	HOLDDOWN, TERMINAL	65	
-	1	1	2168083-2	SCR, SKT HD CAP, RoHS, M4 X 8.0	60	
-	1	1	5-18022-5	SCR, HEX HD CAP, M4 X 6.0	59	
-	4	4	2168400-4	SHCS, LOW HEAD, RoHS, M4 X 8	57	
-	2	2	2168083-3	SCR, SKT HD CAP, RoHS, M4 X 12.0	56	
-	2	2	5018030-1	NUT, HEX, REG, RoHS, M3	54	
-	2	2	986965-8	NUT, LOCK, HEX, TORQUE (M4)	53	
-	1	1	1-5018030-0	NUT, HEX, REG, RoHS, M3.5	52	
-	1	1	2063961-9	FEED FINGER	51	
-	1	1	1752354-3	STANDOFF,HOLD-DOWN	50	
-	1	1	18023-9	SCR, SKT HD CAP M4 X 6.0	49	
-	1	1	2119655-5	APPLICATOR BASIC ASSEMBLY, EF	46	
-	1	1	1803517-1	RAM ASSEMBLY, EF ATLANTIC	44	
-	1	1	1803602-1	SCR, BHSC, RoHS (M8 X 25)	41	
-	8	8	1-18028-2	WASHER, FLAT, REG M4	33	
-	2	2	2168083-9	SCR, SKT HD CAP, RoHS, M4 X 20	31	
-	2	2	2168083-2	SCR, SKT HD CAP, RoHS, M4 X 8.0	29	
-	1	1	240639-1	STRIPPER (MACHINING)	27	
-	2	2	1-2168083-5	SCR, SKT HD CAP, RoHS, M4 X 30	25	
-	1	1	1752371-1	PLATE, STRIP GUIDE	24	
-	2	2	2-22281-3	SPRING, COMPRESSION	22	
-	1	1	1803292-1	DRAG	20	
-	1	1	1-1901696-5	STRIP GUIDE, REAR	19	
-	1	1	1-1901695-5	STRIP GUIDE, FRONT	18	
-	4	4	1-2079383-1	SCR, BHSC, RoHS (M6 X 12)	17	
-	1	1	240641-6	SPACER	16	
-	1	1	1752360-1	SPACER,HOLD-DOWN	13	
-	1	1	240644-1	PLATE, REAR SHEAR	11	
-	1	1	690482-5	PLATE, FRONT SHEAR	9	
-	1	2	1	1333221-4	ANVIL, EF .130	8
-	1	1	1	4-690474-2	BLADE, SLUG	7
-	1	1	1	3-240641-1	SPACER	5
-	1	1	1	238011-2	BLOCK, CRIMPER SPACER	4
-	1	2	1	1-2119785-6	CRIMPER, INSULATION OVERLAP PREMIUM	3
-	1	1	1	455888-8	SPACER, CRIMPER	2
-	1	2	1	456410-2	CRIMPER, WIRE PREMIUM	1
-	77	-72	-2	PART NO	DESCRIPTION	ITEM NO

DIMENSIONS:		TOLERANCES UNLESS OTHERWISE SPECIFIED:		DRAWN		DATE	
mm	0 PLC ±	1 PLC ±	2 PLC ±	X. ZHAO	15FEB2012	TE Connectivity	15FEB2012
	3 PLC ±	4 PLC ±	ANGLES ±	T. ELBIN	15FEB2012	Harrisburg, PA 17105-3608	
	FINISH						
MATERIAL				APVD		NAME	
				S. XI		Ocean End Feed Applicator	
				APPLICATION SPEC		SIZE	
						A   00779 C=2150156	
				WEIGHT		SCALE	
						1:1 SHEET 1 OF 4	
				Customer Accessible Production Drawing		REV E	

LOC	DIST	REVISIONS			
P	LTN	DESCRIPTION	DATE	OWN	APVD
A	66	SEE SHEET 1			

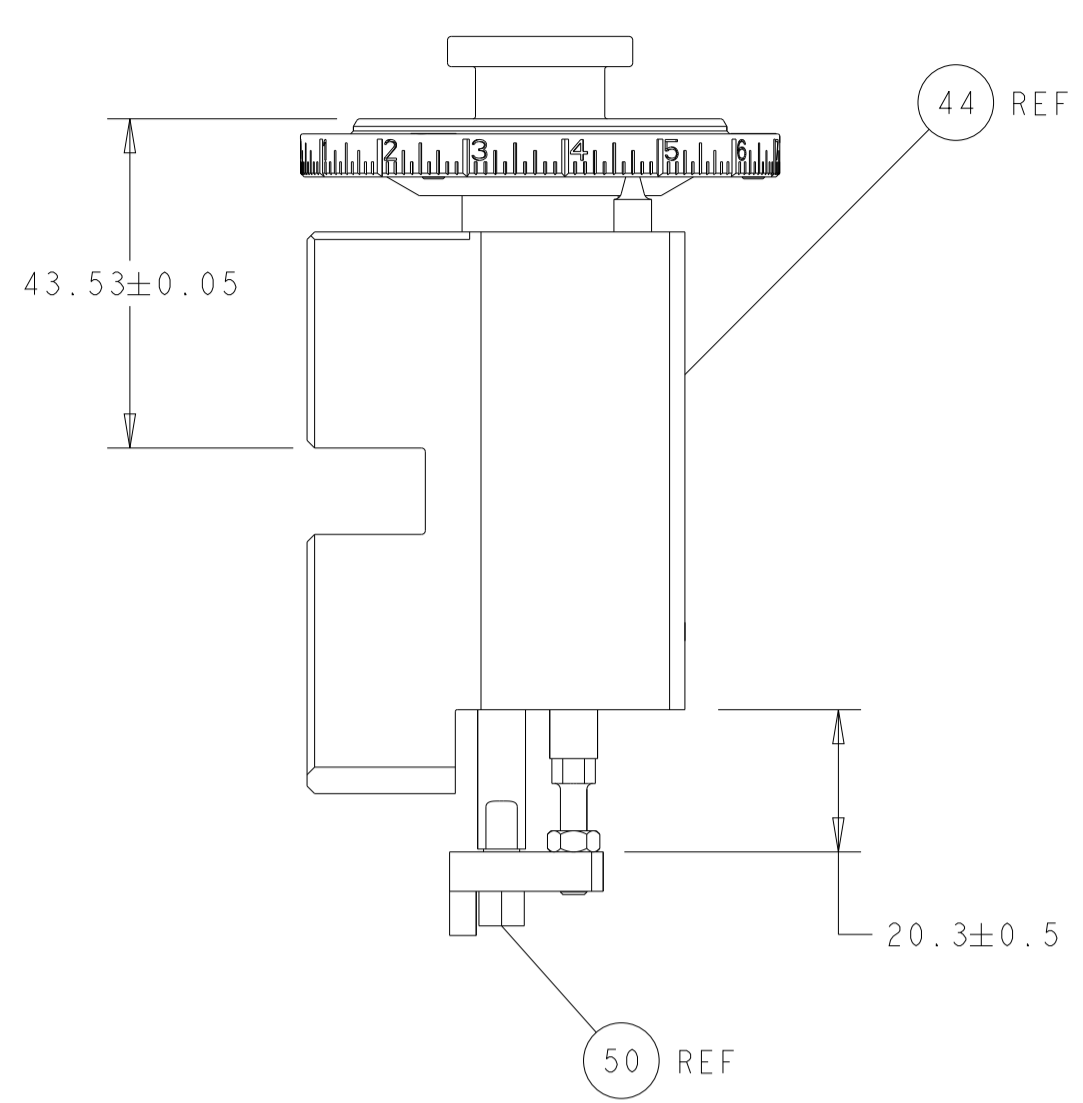

RAM AND HOLDDOWN SET-UP

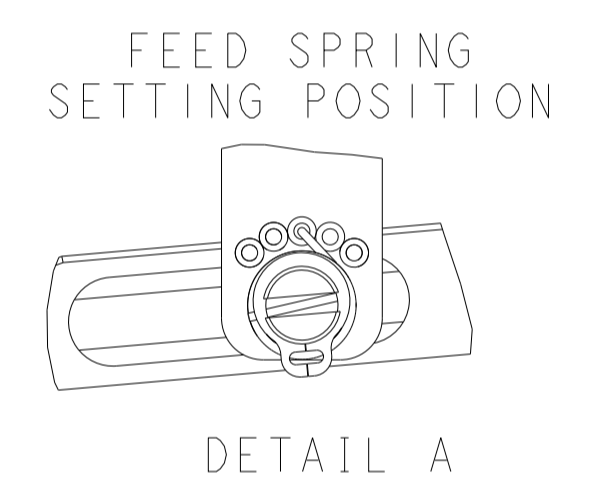
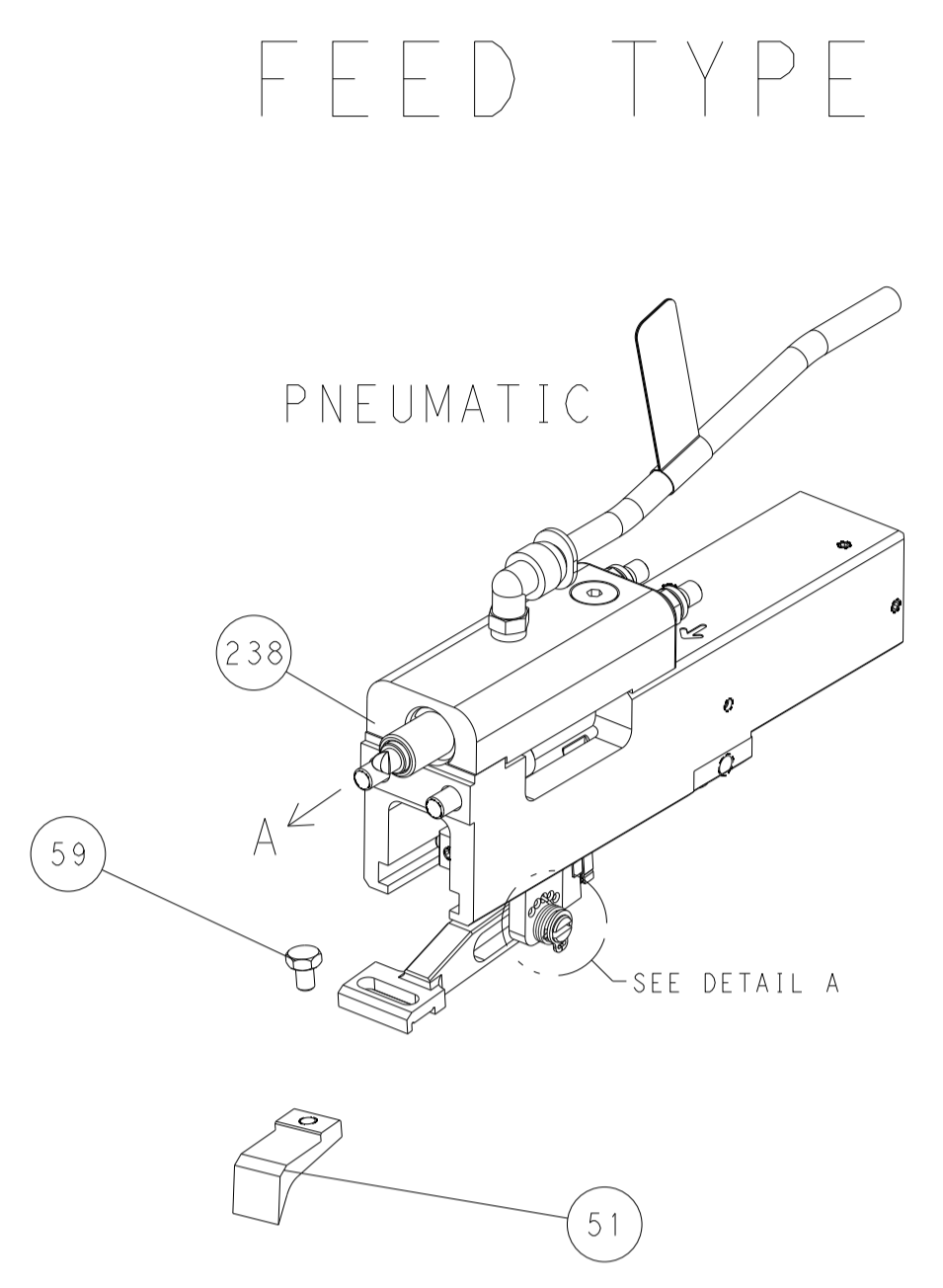
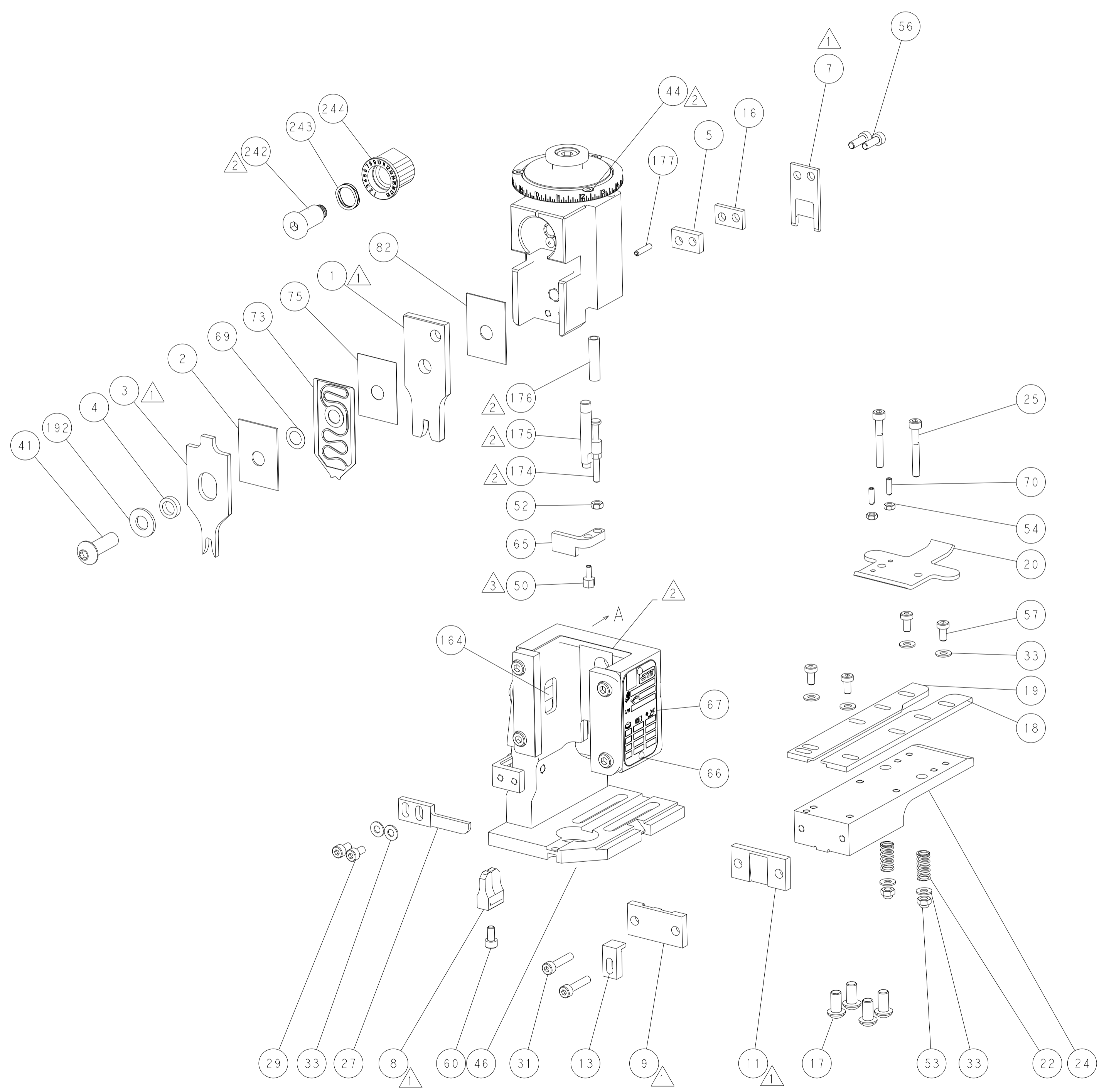

CAM POSITION

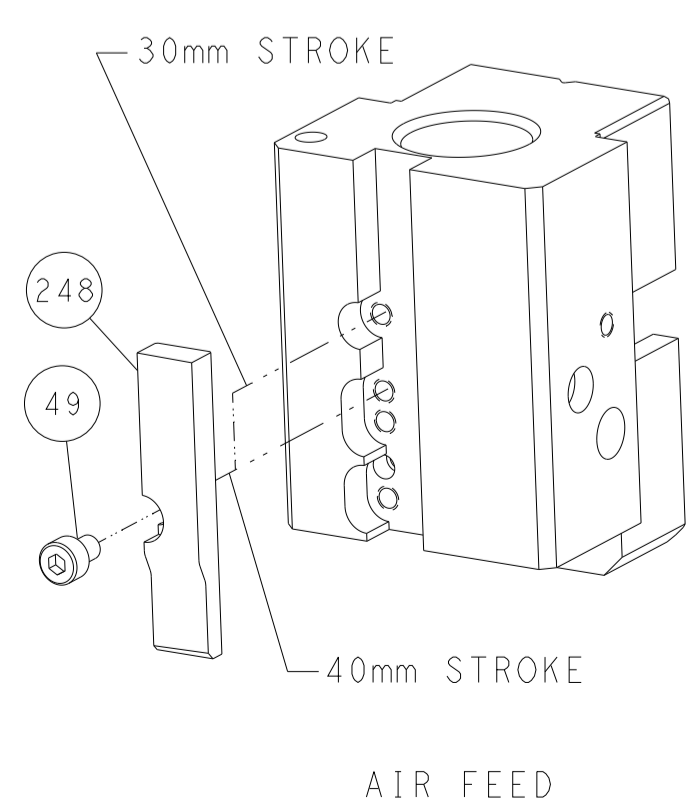

ATLANTIC VERSION  
 Shown on sheets 1 of 4 & 2 of 4  
 (Pacific version shown on sheets 3 of 4 & 4 of 4)

<small>THIS DRAWING IS A CONTROLLED DOCUMENT FOR TYCO ELECTRONICS CORPORATION. IT IS THE PROPERTY OF TYCO ELECTRONICS CORPORATION AND IS NOT TO BE REPRODUCED OR TRANSMITTED IN ANY FORM OR BY ANY MEANS, ELECTRONIC OR MECHANICAL, INCLUDING PHOTOCOPYING, RECORDING, OR BY ANY INFORMATION STORAGE AND RETRIEVAL SYSTEM, WITHOUT THE WRITTEN PERMISSION OF TYCO ELECTRONICS CORPORATION.</small>		DWN X.ZHAO 15FEB2012 CHK T.ELBIN 15FEB2012 APVD S.XI 15FEB2012	TE Connectivity Harrisburg, PA 17105-3608
DIMENSIONS: mm 		TOLERANCES UNLESS OTHERWISE SPECIFIED: 0 PLC ± 1 PLC ± 2 PLC ± 3 PLC ± 4 PLC ± ANGLES ± FINISH ±	NAME Ocean End Feed Applicator SIZE A1 CAGE CODE 00779 DRAWING NO. C=2150156 RESTRICTED TO
MATERIAL:		WEIGHT:	SCALE 1:1 SHEET 2 OF 4 REV E

PART NUMBER	REVISION	DESCRIPTION	FEED TYPE
2-2150156-2	E	FINE CRIMP HEIGHT ADJUST	PNEUMATIC
7-2150156-7	A	CRIMP TOOLING KIT	-

PACIFIC VERSION TERMINATOR  
 INTERFACE ADAPTER

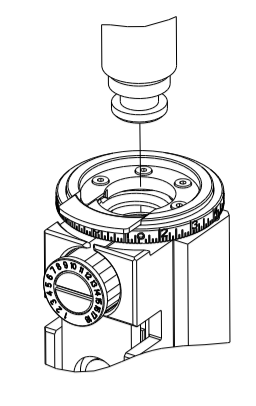

APPLICATOR DATA		
CRIMP	SIZE	TYPE
WIRE	3.30 mm [.130]	F
INSUL	3.94 mm [.155]	OV
APPL INSTRUCTIONS 408-35043		

TERMINAL DATA: TE TERMINAL		TE CRIMP SPECIFICATION	
TERMINAL NAME: RING TONGUE			
WIRE STRIP LENGTH		INSULATION DIAMETER RANGE	
5.50-5.80 mm [.217-.228 IN]		∅2.20-3.00 mm [.087-.118 IN]	
TERMINAL APPLICATION SPECIFICATION	114-18022	-	-
TERMINALS APPLIED			
TE TERMINAL	TE TERMINAL	TE TERMINAL	TE TERMINAL
346101-2			

WIRE SIZE	CRIMP HEIGHT mm [INCH]	CRIMP HEIGHT REFERENCE SETTING
2.50mm2	2.40 +/- 0.05 [.094 +/- .002]	4.3
2.00mm2	2.28 +/- 0.05 [.090 +/- .002]	5.5
1.50mm2	2.16 +/- 0.05 [.085 +/- .002]	6.6



- RECOMMENDED SPARE PARTS
- REFER TO SUPPLIED INSTRUCTION SHEET FOR CLEANING, LUBRICATION AND STORAGE OF APPLICATOR.
- APPLY PART NUMBER 1-23419-5 LOCTITE TO THREADS OF ITEM 50. APPLY PART NUMBER 2-23419-6 LOCTITE TO THREADS OF ITEM 242.
- CRIMP HEIGHT REFERENCE SETTING WAS THE SETTING USED WHEN THE APPLICATOR WAS QUALIFIED AT THE FACTORY. ADJUSTMENT MAY BE NECESSARY WHEN RUNNING APPLICATOR IN THE FIELD.
- TERMINAL PITCH NOT COMPATIBLE WITH MECHANICAL FEED.
- 6. UNLESS SPECIFIED OTHERWISE TORQUE VALUES SHALL BE USED PER DOCUMENT, 101-35000.

**\*WARNING**  
 ON INSTALLATION, SET WIRE DISC TO CRIMP HEIGHT REFERENCE SETTING FOR LARGEST WIRE SIZE. CRIMP HEIGHT REFERENCE SETTINGS GREATER THAN THE VALUE SHOWN MAY CAUSE DAMAGE TO THE CRIMP TOOLING, REFER TO THE INSTRUCTION SHEET FOR PROPER SETUP AND ADJUSTMENTS.

**PACIFIC VERSION**  
 Shown on sheets 3 of 4 & 4 of 4  
 (Atlantic version shown on sheets 1 of 4 & 2 of 4)

LOC	DIST	REVISIONS					
A	66	P	LTN	DESCRIPTION	DATE	OWN	APVD
		-		SEE SHEET 1	-	-	-

-	1	2119082-9	CAM, SNAIL, INSULATION ADJUSTMENT	244	
-	1	2079764-1	WASHER, WAVE SPRING, CREST-TO-CREST	243	
	-	1	2119083-1	RETAINER, INSULATION DIAL	242
-	1	2844940-4	AIR FEED MODULE	238	
-	1	1-18028-0	WASHER, FLAT, REG M8	192	
-	4	2079383-9	SCR, BHSC, RoHS (M6 X 20)	186	
-	1	6-993111-6	PIN, SLOTTED SPRING 3.0 X 14.0	177	
-	1	8-22280-7	SPRING, COMPRESSION	176	
-	1	1752353-2	GUIDE PIN, HOLDDOWN	175	
-	1	1901680-2	GUIDE PIN, HOLDDOWN	174	
-	REF	994970-2	COUNTER, MAGNETIC	164	
-	1	2119641-2	FEED CAM, AIR FEED	152	
-	1	2168083-8	SCR, SKT HD CAP, RoHS, M4 X 16	144	
-	1	2119655-6	APPLICATOR BASIC ASSEMBLY, EF	141	
-	1	1803518-1	RAM ASSEMBLY, EF PACIFIC	140	
-	1	455888-6	SPACER, CRIMPER	82	
-	1	455888-2	SPACER, CRIMPER	75	
-	1	2119791-9	DEPRESSOR, WIRE	73	
-	1	1803607-4	DOCUMENTATION PACKAGE	71	
-	2	2-18032-2	SCR, SET, FLT PNT, M3 X 10.0	70	
-	1	2119943-1	WASHER, SPACER	69	
-	1	2119740-1	TAG, IDENTIFICATION	67	
-	2	2168078-1	SCREW, DRIVE, RH, RoHS, 2 x .188	66	
-	1	1901681-5	HOLDDOWN, TERMINAL	65	
-	1	5-18022-5	SCR, HEX HD CAP, M4 X 6.0	59	
-	4	2168400-4	SHCS, LOW HEAD, RoHS, M4 X 8	57	
-	2	2168083-3	SCR, SKT HD CAP, RoHS, M4 X 12.0	56	
-	2	5018030-1	NUT, HEX, REG, RoHS, M3	54	
-	2	986965-8	NUT, LOCK, HEX, TORQUE (M4)	53	
-	1	1-5018030-0	NUT, HEX, REG, RoHS, M3.5	52	
-	1	2063961-9	FEED FINGER	51	
	-	1	1752354-3	STANDOFF, HOLD-DOWN	50
-	1	18023-9	SCR, SKT HD CAP M4 X 6.0	49	
-	1	1803602-1	SCR, BHSC, RoHS (M8 X 25)	41	
-	8	1-18028-2	WASHER, FLAT, REG M4	33	
-	2	2168083-9	SCR, SKT HD CAP, RoHS, M4 X 20	31	
-	2	2168083-2	SCR, SKT HD CAP, RoHS, M4 X 8.0	29	
-	1	240639-1	STRIPPER (MACHINING)	27	
-	2	1-2168083-5	SCR, SKT HD CAP, RoHS, M4 X 30	25	
-	1	1752371-1	PLATE, STRIP GUIDE	24	
-	2	2-22281-3	SPRING, COMPRESSION	22	
-	1	1803292-1	DRAG	20	
-	1	1-1901696-5	STRIP GUIDE, REAR	19	
-	1	1-1901695-5	STRIP GUIDE, FRONT	18	
-	1	240641-6	SPACER	16	
	-	1	1752360-1	SPACER, HOLD-DOWN	13
-	1	240644-1	PLATE, REAR SHEAR	11	
	-	1	690482-5	PLATE, FRONT SHEAR	9
	1	1	1333221-4	ANVIL, EF .130	8
	-	1	4-690474-2	BLADE, SLUG	7
-	1	3-240641-1	SPACER	5	
-	1	238011-2	BLOCK, CRIMPER SPACER	4	
	1	1	1-2119785-6	CRIMPER, INSULATION OVERLAP PREMIUM	3
-	1	455888-8	SPACER, CRIMPER	2	
	1	1	456410-2	CRIMPER, WIRE PREMIUM	1
-	77-22		PART NO	DESCRIPTION	ITEM NO

DIMENSIONS:		TOLERANCES UNLESS OTHERWISE SPECIFIED:		MATERIAL:	
mm	0 PLC ±	1 PLC ±	2 PLC ±	3 PLC ±	4 PLC ±
	ANGLES	FINISH			
DWG: X.ZHAO 15FEB2012		CHK: T.ELBIN 15FEB2012		APVD: S.XI 15FEB2012	
NAME: Ocean End Feed Applicator		SIZE: A1		CAGE CODE: 00779	
DRAWING NO: 2150156		SCALE: 1:1		SHEET 3 OF 4	
Customer Accessible Production Drawing		REV: E			

LOC	DIST	REVISIONS			
P	LTN	DESCRIPTION	DATE	DMN	APVD
A	66	SEE SHEET 1	-	-	-

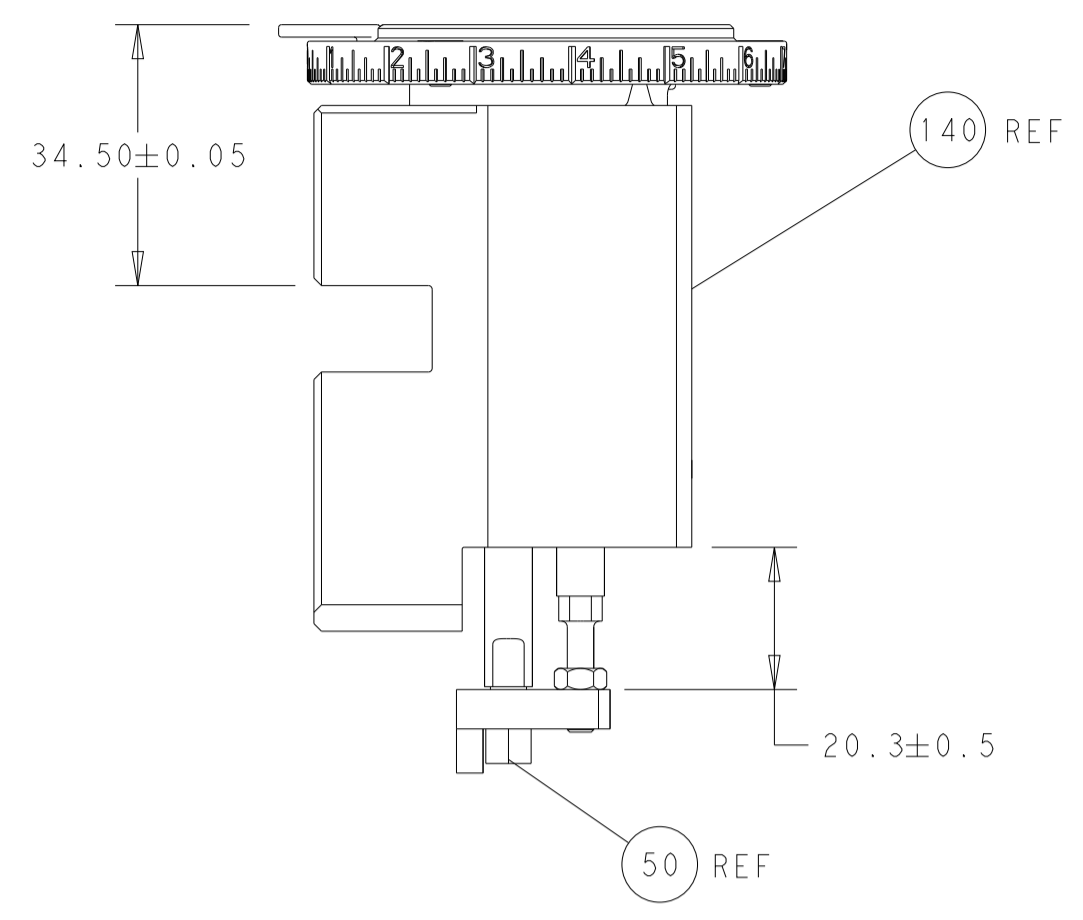

RAM AND HOLDDOWN SET-UP

FEED TYPE

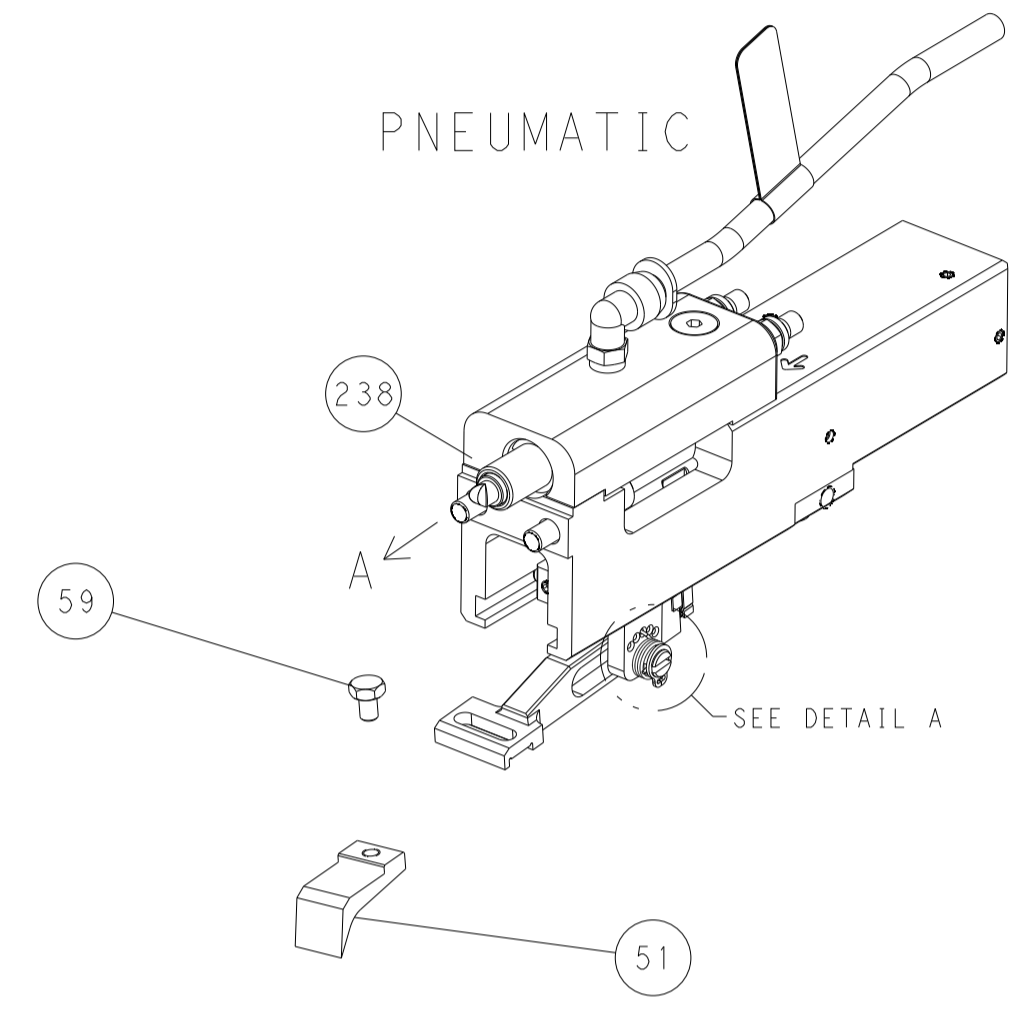

FEED SPRING SETTING POSITION

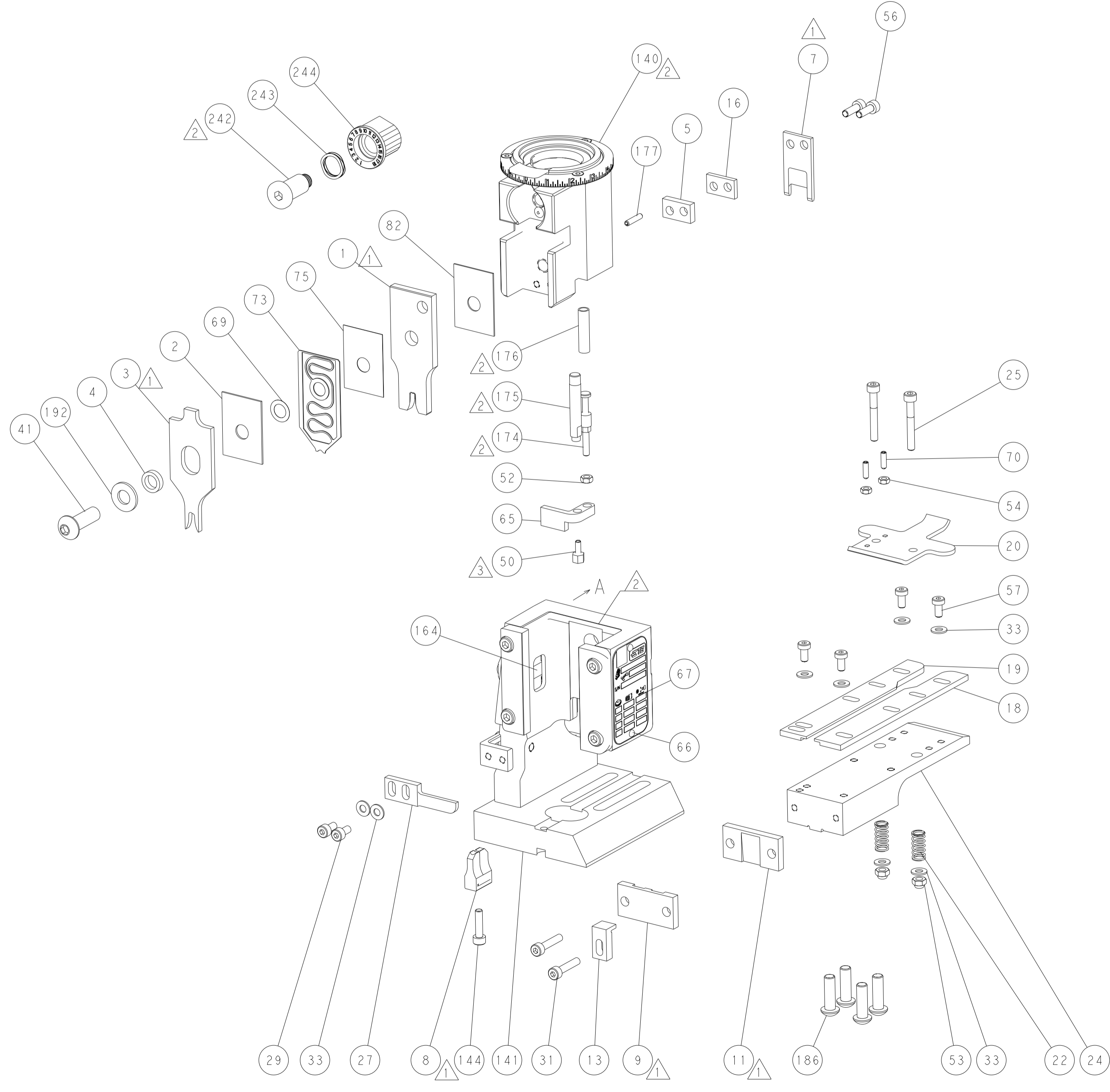
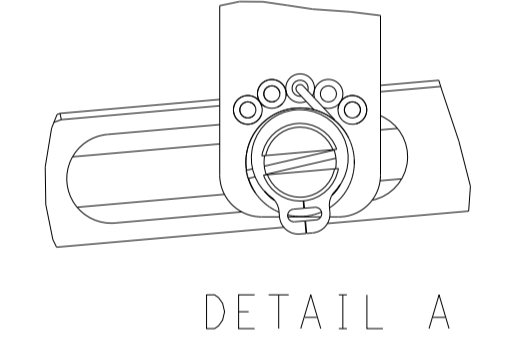

CAM POSITION

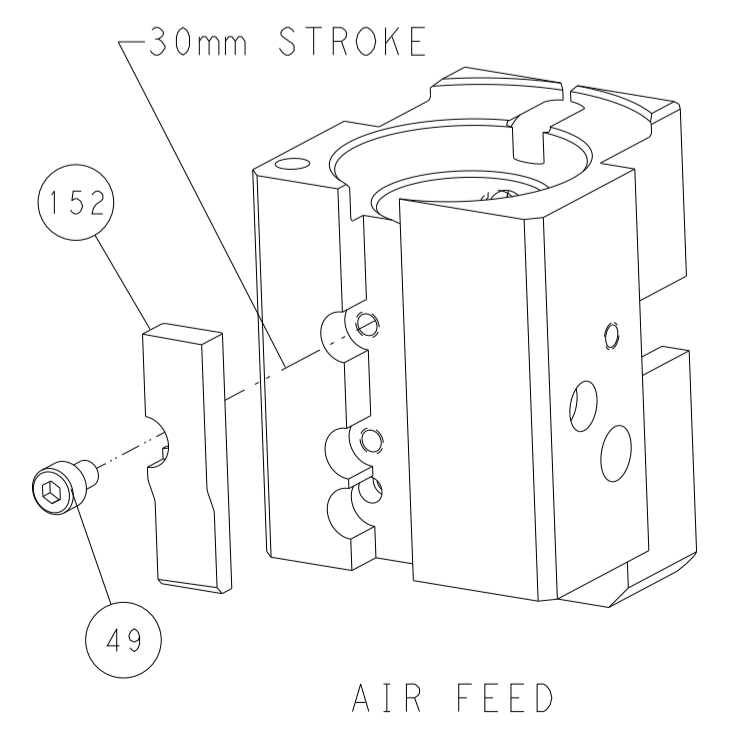

AIR FEED

PACIFIC VERSION  
 Shown on sheets 3 of 4 & 4 of 4  
 (Atlantic version shown on sheets 1 of 4 & 2 of 4)

DIMENSIONS:		TOLERANCES UNLESS OTHERWISE SPECIFIED:		DWG X_ZHAO 15FEB2012		TE Connectivity	
mm	0 PLC ±	1 PLC ±	2 PLC ±	3 PLC ±	4 PLC ±	5 PLC ±	Harrisburg, PA 17105-3608
MATERIAL:	FINISH:	WEIGHT:	SCALE:	APVD S_XI 15FEB2012	NAME	SIZE	CAGE CODE
			1:1	Customer Accessible Production Drawing	Ocean End Feed Applicator	A1	00779
							©=2150156
							Customer Accessible Production Drawing
							SCALE 1:1 SHEET 4 OF 4 REV E