

REVISIONS

P	LTR	DESCRIPTION	DATE	DWN	APVD
A		SQUARE NUT PART INFORMATION ADDED	13APR2018	RK	PS

NOTES:

- MATERIALS AND FINISH:  
HOUSING: HIGH TEMPERATURE POLYAMIDE, UL94V-0,  
COLOR: BLACK.  
TERMINAL: PHOSPHOR BRONZE, TIN PLATED.  
SQUARE NUT: BRASS, NICKEL PLATED.
- MECHANICAL  
MAX. INSERTION FORCE PER POLE : 3.0 N  
MIN. WITHDRAWAL FORCE PER POLE : 1.5 N  
MIN. PC BOARD HOLES DIAMETER : 1.2 mm  
MAX. PC BOARD THICKNESS : 2.4 mm
- ELECTRICAL  
WIRE RANGE : 14-30 AWG  
MAX. VOLTAGE : 300 V  
MAX CURRENT : 11 A  
CONTACT RESISTANCE : <15 m Ohm  
INSULATION RESISTANCE : >1000 M Ohm (500V DC)
- OPERATING TEMPERATURE RANGE: -40°C TO +110°C
- CONNECTOR ASSEMBLY INCLUDED 2 SQUARE NUTS LOADED IN CAVITY.

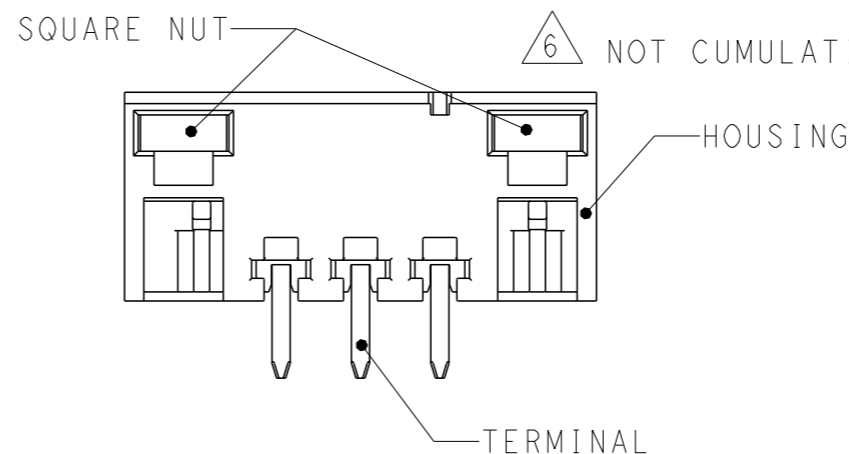
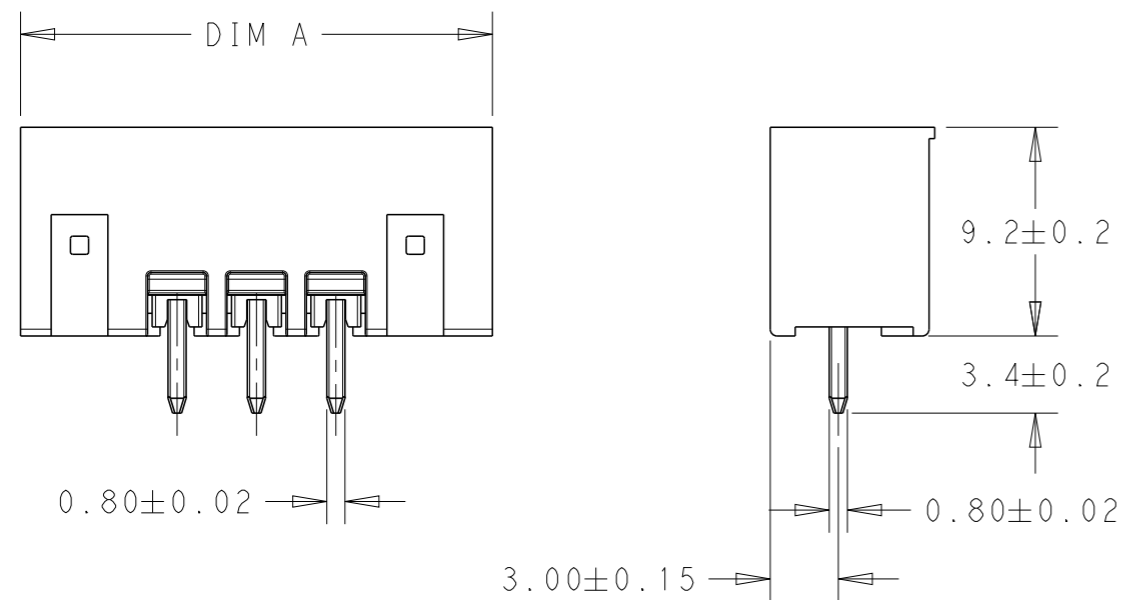
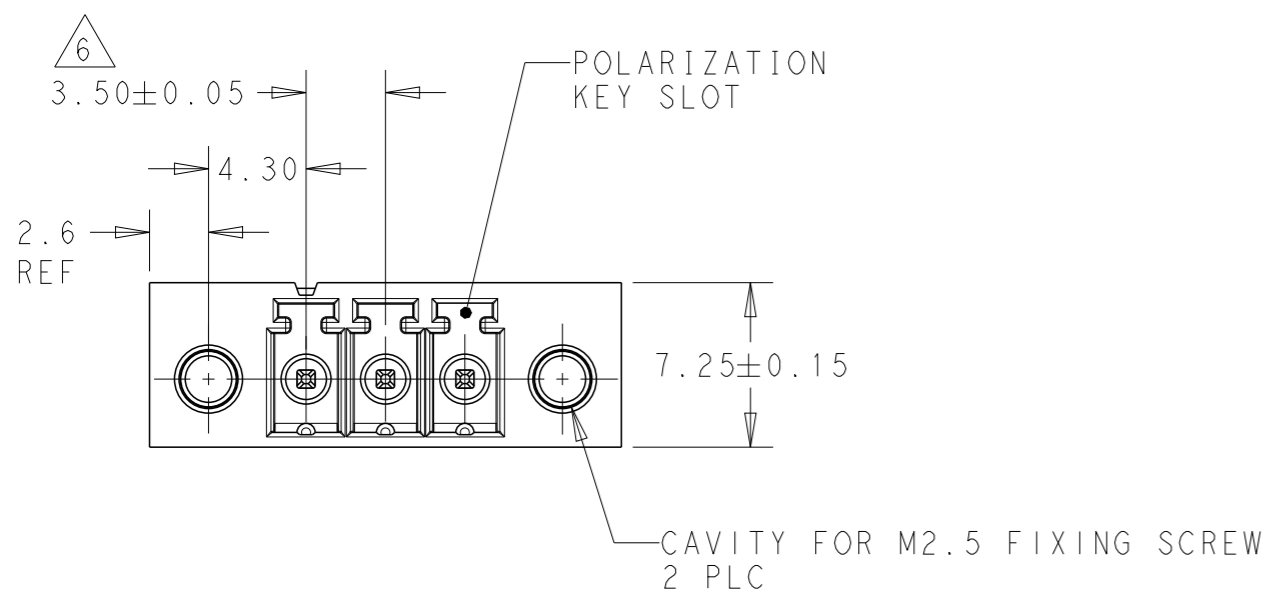

52.3	12	1-177132-2
48.8	11	1-177132-1
45.3	10	1-177132-0
41.8	9	177132-9
38.3	8	177132-8
34.8	7	177132-7
31.3	6	177132-6
27.8	5	177132-5
24.3	4	177132-4
20.8	3	177132-3
17.3	2	177132-2
DIM A	NO OF POS.	PART NUMBER

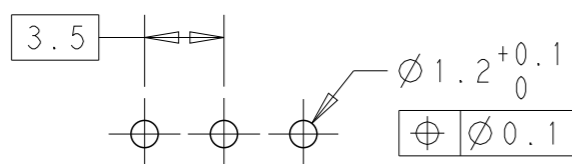

RECOMMENDED PC BOARD LAYOUT

THIS DRAWING IS A CONTROLLED DOCUMENT.		DWN S. SCHLEGEL 06 JAN 2010	 TE Connectivity	
DIMENSIONS: mm		CHK C RICHARD 06 JAN 2010		
TOLERANCES UNLESS OTHERWISE SPECIFIED:		APVD C RICHARD 06 JAN 2010	NAME TERMINAL BLOCK HEADER ASSEMBLY, STRAIGHT, W/ THREADED FLG, 3.5mm PITCH	
0 PLC ± 1 PLC ±0.3 2 PLC ±0.25 3 PLC ± 4 PLC ±		PRODUCT SPEC	SIZE A300779	
ANGLES ±2		APPLICATION SPEC	DRAWING NO C=1776132	
MATERIAL SEE NOTES		FINISH SEE NOTES	RESTRICTED TO -	
CUSTOMER DRAWING		WEIGHT -	SCALE 3:1	
		SHEET 1 OF 1		REV A