

SECTION A-A

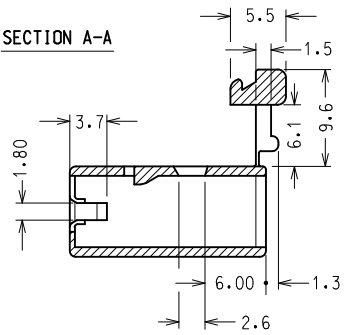

SECTION B-B

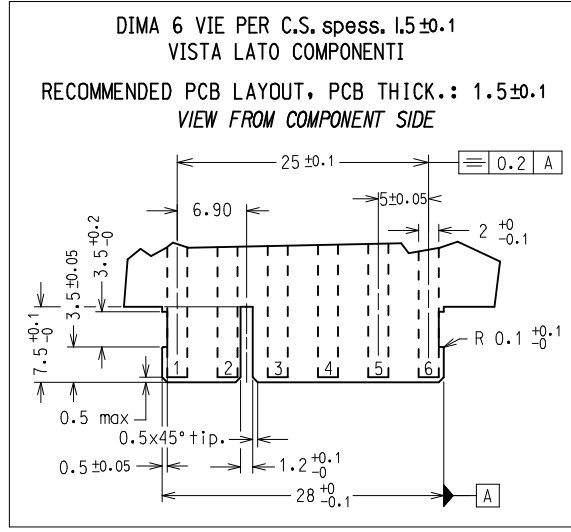
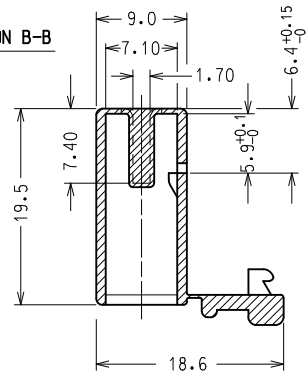

CODICE P/N	MATERIAL AND COLOR
94529-9106	NYLON 66 UL94 V2 NATURAL
94529-9206	NYLON 66 UL94 V2 BLACK
94529-7106	NYLON 66 UL94 V0 NATURAL
94529-7206	NYLON 66 UL94 V0 GREY
94529-4106	NYLON 6.6 GWT 750°C sec. IEC 60335-1 TEST METHOD IEC 60695-2-11 NATURAL
94529-4206	NYLON 6.6 GWT 750°C sec. IEC 60335-1 TEST METHOD IEC 60695-2-11 BLACK

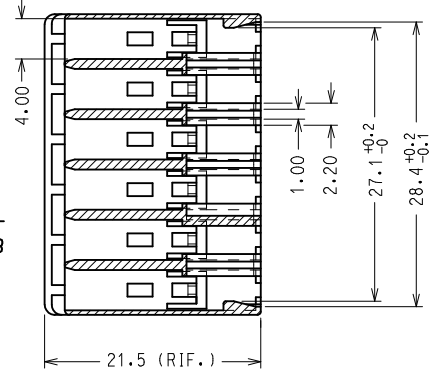
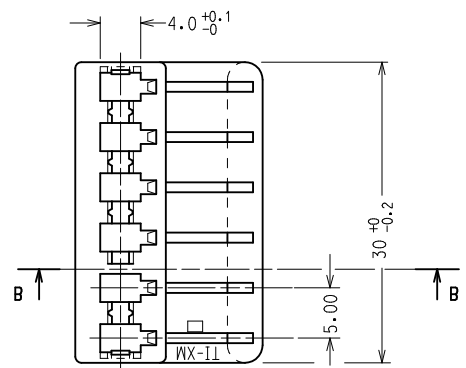
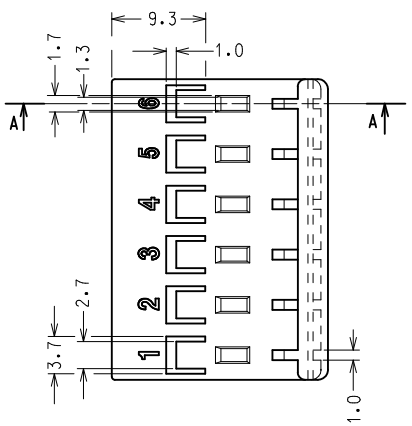

NOTA: LE DIMENSIONI VANNO MISURATE CON CORPI STABILIZZATI SECONDO NG 2301. (AUMENTO IN PESO DEL 2.7 %)

NOTE: PARTS SHALL BE DIMENSIONALLY CHECKED AFTER ATTAINING EQUILIBRIUM CONDITIONS E.G. 27 % INCREASE IN WEIGHT FOR HUMIDITY ABSORPTION FROM DRY STATUS.

CARATTERISTICHE PRODOTTO SECONDO PS-94529
PRODUCT CHARACTERISTICS ACCORDING TO PS-94529 E

CONFEZIONE: 2000 pz. IN SCATOLA
PACKAGING: 2000 pcs IN CARTON BOX

SPQ: 2000 pz.

Descr. Std: HSG FOR FORK TERMINAL 6 CKT

EC NO: Z2006-0051 DRWN: FGOTTARD 2005/10/12 CHKD: RSANDANI 2005/10/12 APPR: GZUJIN 2005/10/14	QUALITY SYMBOLS	GENERAL TOLERANCES (UNLESS SPECIFIED)	SCALE 2:1	DESIGN UNITS METRIC	FIRST ANGLE PROJECTION	REVISE ON CAD ONLY
	▲ = 0 ▽ = 0	mm	INCH	DIMENSION STYLE MM ONLY		TITLE 6 CKT HOUSING FOR STRAIGHT FORK TERMINAL
		4 PLACES ± --- ± ---	3 PLACES ± --- ± ---	DRAWN BY DATE	FGOTTARD 1995/10/25	
		2 PLACES ± 0.1 ± ---	1 PLACE ± 0.2 ± ---	CHECKED BY DATE	SSORATO 1995/10/25	
A4	REV	ANGULAR ± 2°	DRAFT WHERE APPLICABLE MUST REMAIN WITHIN DIMENSIONS		APPROVED BY DATE	MATERIAL NO. SEE TAB. DOCUMENT NO. SD-94529-008 SHEET NO. 1 OF 1