

| PART NO. | BASE TYPE | DESIGN VOLTS | DESIGN AMPS | MSCD | FILAMENT TYPE | AVG LIFE |
|----------|-----------------------------|--------------|---------------|---------------|---------------|----------|
| 1889 | MIN. BAYONET Bays T3 1/4 | 14.0 | .27A ± 10% | 2.00 ± 20% | C-2F | 1500 |

| REVISIONS | | | |
|-----------|--|----------|----------|
| REV | DESCRIPTION | DATE | APPROVED |
| B | Address Change | 8-4-2008 | S.L. |
| C | Add SAE note, Bead Color & Design Watts. | 8-6-2008 | S.L. |

* SAE J573 Compliance.
Design Watts: 3.78 ± 10%

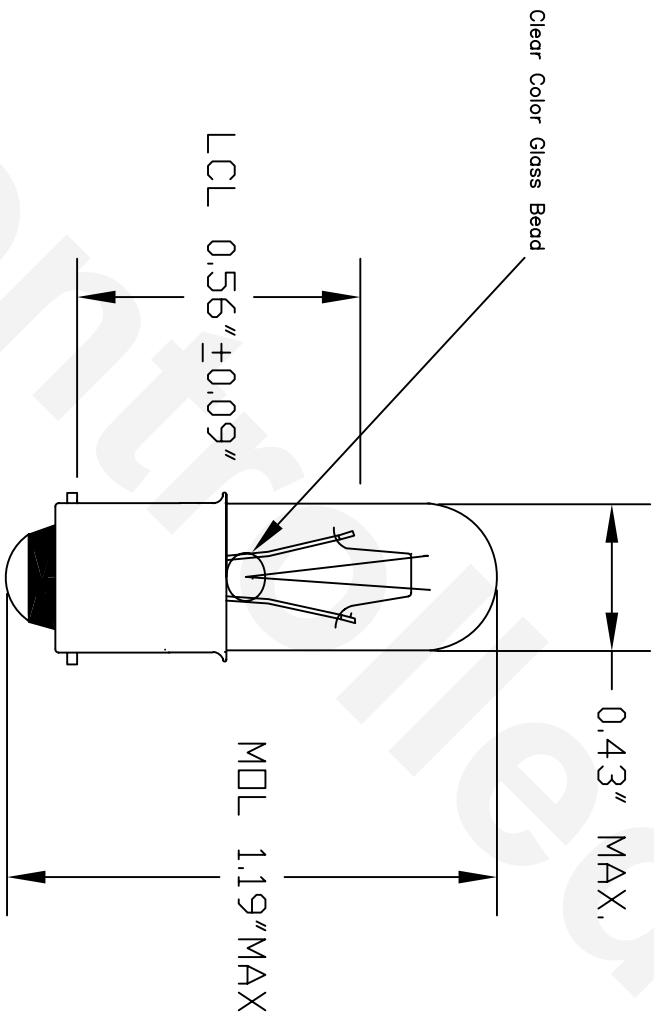

UNLESS OTHERWISE SPECIFIED:
DIMENSIONS ARE IN INCHES
TOLERANCES

| | |
|------------|---------|
| DECIMALS | ANGULAR |
| XX ± .05 | ± 0.5° |
| XXX ± .010 | |
| FRACTIONAL | ± 1/64 |

DRAWN
Anna Soloveychik 01/24/02

CHECKED

DESIGN

MATERIAL

CEC INDUSTRIES LTD
599 BOND STREET
LINCOLNSHIRE, IL 60069

TITLE
LIGHT BULB NO. 1889

| | | | |
|------|----------|----------|-----|
| SIZE | FSCM NO. | DWG NO. | REV |
| A | | 1889.DWG | C |

| | | | | | |
|-------|------------|-------|---|----|---|
| SCALE | PLOT SCALE | SHEET | 1 | OF | 1 |
|-------|------------|-------|---|----|---|

FILE \AUTO CAD FILES\1889.DWG DO NOT SCALE DRAWING