

© - TE Connectivity. All Rights Reserved.

REVISIONS					
P	LTR	DESCRIPTION	DATE	DWN	APVD
	Z	REVISED PER ECR-22-152397	06OCT2022	BB	DSC

AMP WIRE RANGE	Listed FILE E13288	LR7189 Certified
16-14 AWG SOLID OR STRANDED	16-14 AWG SOLID OR STRANDED	16-14 AWG SOLID OR STRANDED

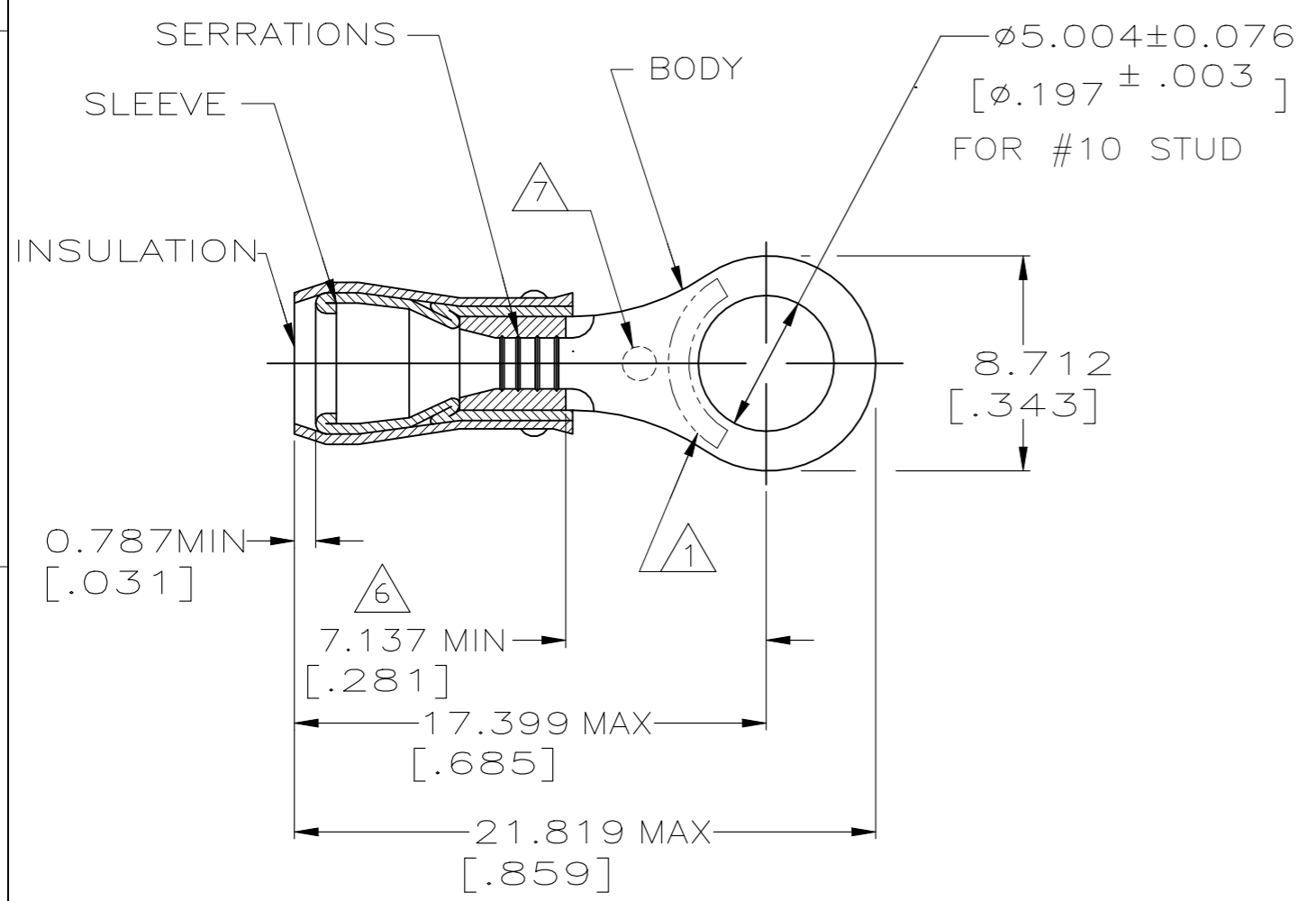

- 1 STAMP AMP 16-14* APPROX AS SHOWN
- 2 WIRE INSULATION DIAMETER:
Ø2.921[.115] TO Ø4.318[.170]
- 3 BODY MATERIAL THK: 0.787±0.051[.031±.002]
- 4 MATERIAL:
BODY & SLEEVE - COPPER PER ASTM B152
INSULATION - PVC
- 5 FINISH:
BODY & SLEEVE - TIN PLATE 0.00254[.000100]
MIN EXT THK PER ASTM B545
INSULATION COLOR - BLUE
- 6 APPLIES FROM EDGE OF METAL WIRE BARREL TO
CENTER OF STUD HOLE
- 7 "O" STAMP MARK OPTIONAL

5000	ON TAPE	2-31903-2
1000	LOOSE PIECE	31903
QUANTITY	PACKAGE TYPE	PART NO

AMP INCORPORATED CUSTOMER SERVICE SYSTEMS		MAX RECOMMENDED OPERATING TEMPERATURE: 105° C [221°F]	THIS DRAWING IS A CONTROLLED DOCUMENT.		DWN JR RUTH 16JAN01	TE Connectivity			
FOR ADDITIONAL PRODUCT INFORMATION OR COPIES OF DRAWINGS AND TECHNICAL DOCUMENTS	PRODUCT INFORMATION CENTER 1-800-522-6752	VOLTAGE RATING: 300 V MAX	DIMENSIONS: mm [INCHES]	TOLERANCES UNLESS OTHERWISE SPECIFIED:	CHK MS FEHER 16JAN01				NAME
FOR APPLICATION TOOLING INFORMATION	TOOLING ASSISTANCE CENTER 1-800-722-1111	WIRE CROSS SECTIONAL AREA RANGE: 1.04-2.62mm ² [2050-5180] CIR MILS SOLID OR STRANDED		0 PLC ± - 1 PLC ± - 2 PLC ± - 3 PLC ± 0.127[.005] 4 PLC ± - ANGLES ± -	APVD T MICHIELUTTI 16JAN01	PRODUCT SPEC			
FOR ORDER ENTRY	1-800-526-5142	THIS DRAWING IS A CONTROLLED DOCUMENT FOR AMP INCORPORATED. IT IS SUBJECT TO CHANGE AND THE CONTROLLING ENGINEERING ORGANIZATION SHOULD BE CONTACTED FOR THE LATEST REVISION.	MATERIAL	FINISH	APPLICATION SPEC UL 486A-B	SIZE	CAGE CODE	DRAWING NO	RESTRICTED TO
					114-2157	A3	00779	C-31903	-
					WEIGHT	CUSTOMER DRAWING		SCALE	SHEET
					-	4:1		1 OF 1	REV Z