

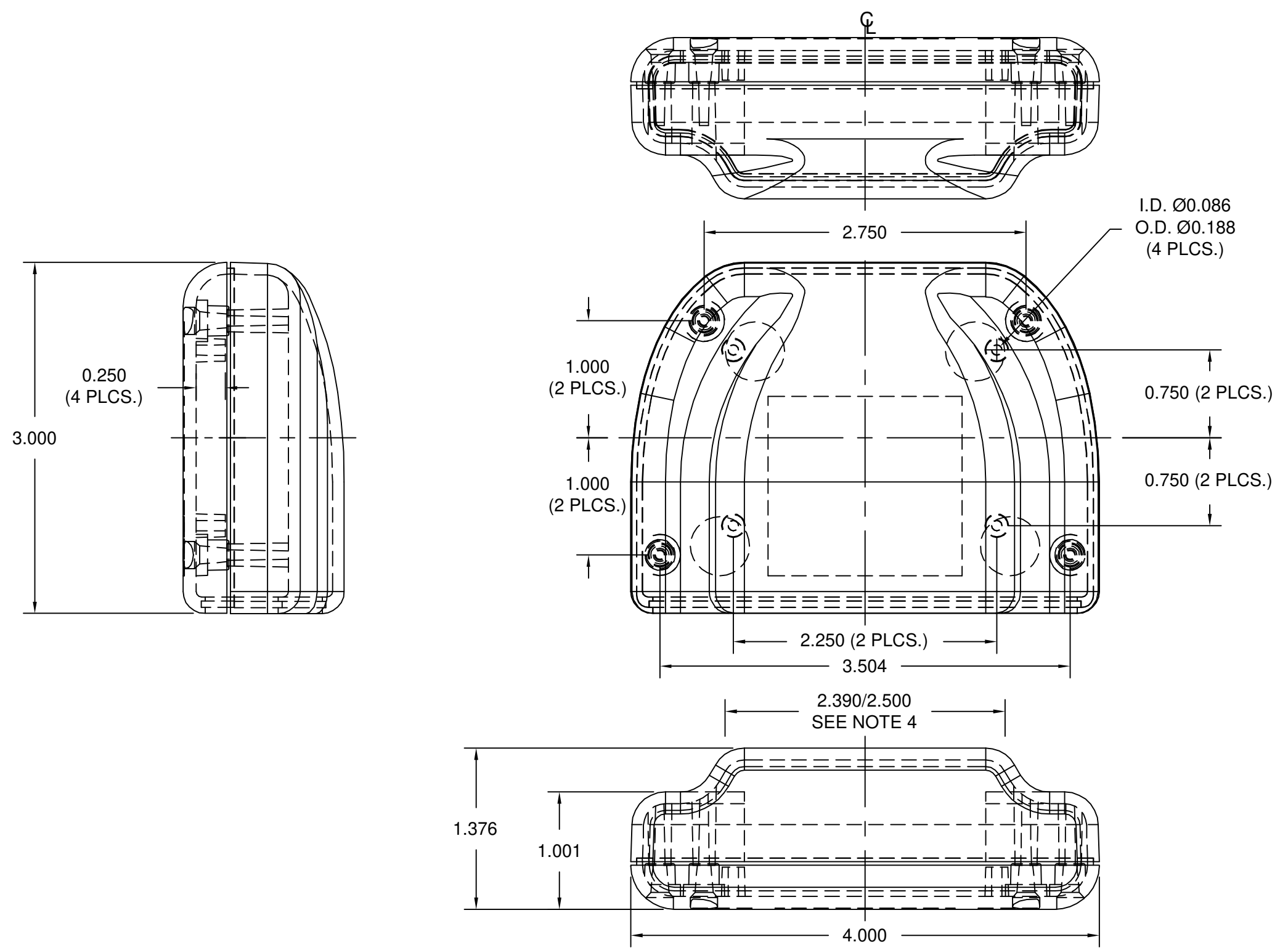

DWG. NO.	PT-11743
ISSUE	REVISIONS



- NOTES:
- 1) PC BOARD BOSSES WILL ACCEPT A #4 X 1/4" THREAD FORMING SCREW
 - 2) MATERIAL: ABS - UL94-5VA
 - 3) FINISH: BLACK TEXTURE
 - 4) DIMENSIONS ARE TO THEORETICAL SHARP CORNERS.
 - 5) INCLUDES (4) #4-24 x 5/8 HI-LOW THREAD FORMING, CSK, OVAL HEAD, PHILLIPS DRIVE SCREWS FOR ATTACHING BODY TO COVER. (MAX TORQUE 4.5 IN-LBS)

ITEM		REQ'D.	PART NO.	DESCRIPTION
TOLERANCES: ±.005 BETWEEN HOLE CENTERS ±.015 FROM SHEARED EDGE ±.032 FROM A BENT SURFACE ±.063 BETWEEN ASSEMBLED SURFACES UNLESS OTHERWISE SPECIFIED		MAT:	AS NOTED	SCALE:
		FINISH:	SEE SPEC.	 BUD INDUSTRIES, INC. WILLOUGHBY, OHIO
		DR. DP	5-23-05	
		CH.		
APP.				DWG. NO. PT-11743

QTY. USED ON