



All numerical values are in metric units [with U.S. customary units in brackets]. Dimensions are in millimeters [and inches]. Unless otherwise specified, dimensions have a tolerance of ± 0.13 [$\pm .005$] and angles have a tolerance of $\pm 2^\circ$. Figures and illustrations are for identification only and are not drawn to scale.

1. INTRODUCTION

This specification covers the requirements for application of Multi-Beam XL cable receptacle assemblies used in power distribution systems. The cable receptacles are available in floating panel-mount and slide-to-lock for panel mount applications and squeeze-to-release for free-hanging applications. The cable receptacles are supplied fully assembled with terminated contacts.



The amount and location of power and signal contacts is customer determined. Different cable receptacle configurations can be designed to meet customer requirements within the limitations stated in this document.

When corresponding with personnel, use the terminology provided in this specification to facilitate your inquiries for information. Basic terms and features of this product are provided in Figure 1.

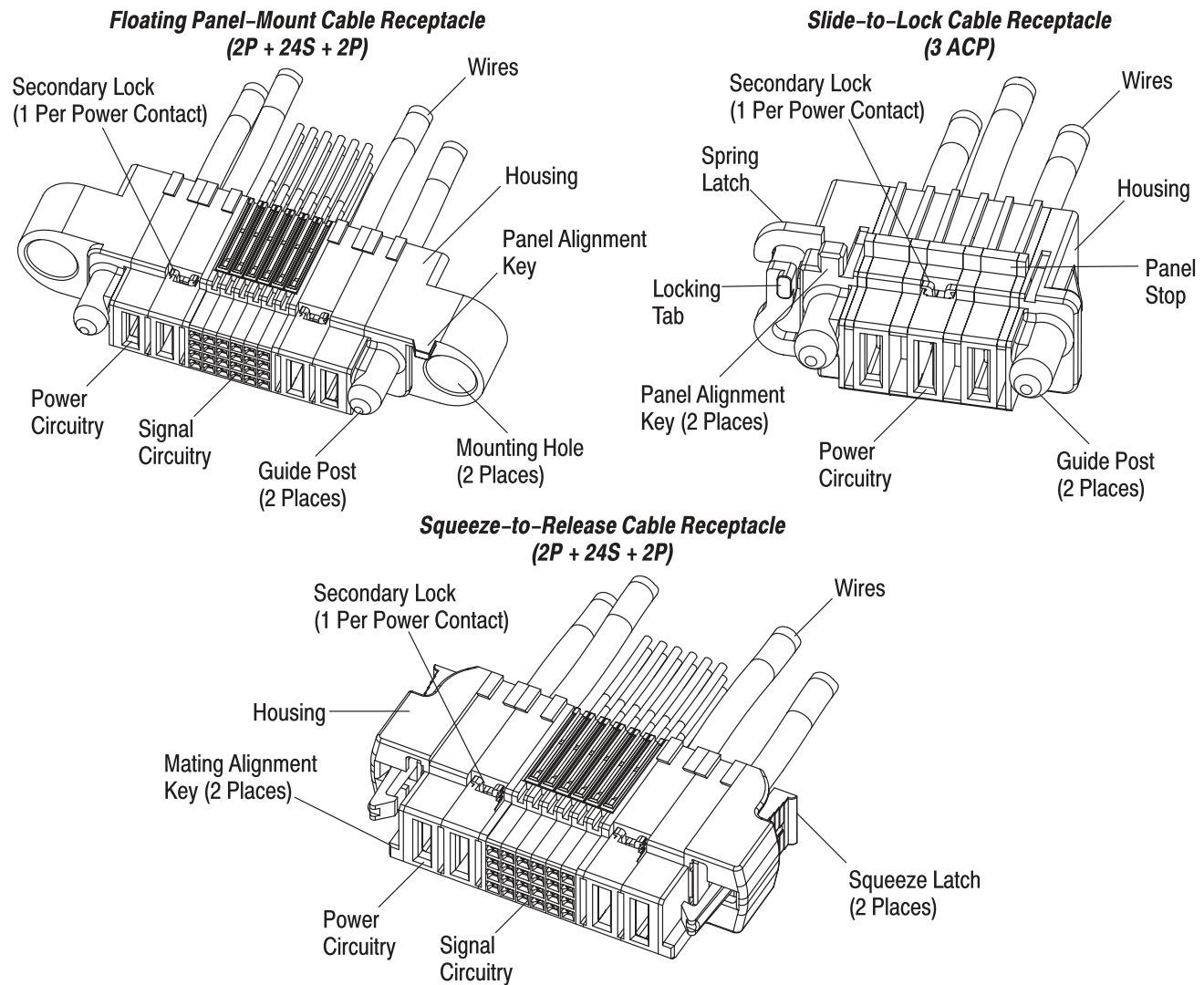

NOTE: 'P' stands for power circuitry with contact centerline spacing of 6.35 [.250], 'S' stands for signal contacts, 'ACP' stands for power circuitry with contact centerline spacing of 7.62 [.300], and 'HDP' stands for high density power circuitry with contact centerline spacing of 5.08 [.200].

Figure 1

The cable receptacles are available with wire sizes 16 through 8 AWG for power contacts and wire sizes 26 through 22 AWG for signal contacts. The cable receptacle is capable of holding combinations of power contacts and/or signal contacts within a maximum length of 157.5 [6.2] between guide posts or squeeze latches.

For sequencing applications, the cable receptacles are available with a standard mating length for signal contacts and two mating lengths for power contacts: standard and make-first-break-last (MFBL) (pre-mate). Signal contacts have a centerline spacing of 2.54 [.100]. Available power contact centerline spacing according to wire size is given in Figure 2.

WIRE		CENTERLINE SPACING OF POWER CONTACTS
SIZE (AWG)	INSULATION DIAMETER	
(2) 16	2.29 [.090] Max	6.35 [.250]
(2) 14	3.48 [.137] Max	7.62 [.300]
(2) 12	3.30 [.130] Max	7.62 [.300]
14	3.05-3.96 [.120-.156]	5.08 [.200] or 6.35 [.250]
12	3.96 [.156] Max	5.08 [.200] or 6.35 [.250]
	3.96-4.47 [.156-.176]	6.35 [.250]
10	4.47-5.46 [.176-.215]	6.35 [.250] or 7.62 [.300]
8	5.46-6.91 [.215-.272]	7.62 [.300]

Figure 2

The housing of the cable receptacle consists of power and/or signal circuitry which accept the contacts, and features that provide for blind mating, misalignment, polarization (mating and panel). Each power contact features a secondary lock that provides a visual indicator for a properly seated contact.

The floating panel-mount and slide-to-lock cable receptacles feature panel alignment key(s) and guide posts. The panel alignment key(s) ensure proper orientation of the cable receptacle to the panel. The guide posts provide ease of mating and are offset to prevent improper mating of connectors. The squeeze-to-release cable receptacle features mating alignment keys that ensure proper orientation of connectors when mating, and squeeze latches to ensure that free-hanging mating connectors do not accidentally back-out.

Mounting holes (which accept hardware available in kits) are used to secure the floating panel-mount cable receptacle to the panel. When mounted, this cable receptacle is designed to "float" in the panel. An integral spring latch with locking tab is used to secure the slide-to-lock cable receptacle to the panel (the panel stop ensures that the locking tab is compatible with the thickness of the panel).

These cable receptacles mate with Multi-Beam XL printed circuit (pc) board header assemblies covered in Application Specification 114-13038.

2. REFERENCE MATERIAL

2.1. Revision Summary

Revisions to this application specification include:

- Updated document to corporate requirements

2.2. Customer Assistance

Reference Product Base Part Numbers 1600636 (floating panel-mount), 1761419 (slide-to-lock), 1600688 (squeeze-to-release), and 1600914 (panel mount hardware kit) and Product Code H091 are representative of Multi-Beam XL cable receptacle assemblies. Use of these numbers will identify the product line and expedite your inquiries through a service network established to help you obtain product and tooling information. Such information can be obtained through a local Representative or, after purchase, by calling PRODUCT INFORMATION at the number at the bottom of page 1.

2.3. Drawings

Customer Drawings for product part numbers are available from the service network. If there is a conflict between the information contained in the Customer Drawings and this specification or with any other technical documentation supplied, call PRODUCT INFORMATION at the number at the bottom of page 1.

2.4. Specifications

Application Specification 114-13038 provides product description and application requirements for Multi-Beam XL connectors.

Product Specification 108-2157 provides product performance and test information.

2.5. Standards

These cable receptacles comply to Electronic Industries Alliance (EIA)-364, "Electrical Connector Test Procedures Including Environmental Classifications".

3. REQUIREMENTS

3.1. Safety

Do not stack product shipping containers so high that the containers buckle or deform.

3.2. Storage

A. Ultraviolet Light

Prolonged exposure to ultraviolet light may deteriorate the chemical composition used in the cable receptacle material.

B. Shelf Life

The cable receptacles should remain in the shipping containers until ready for use to prevent deformation to the contacts. The cable receptacles should be used on a first in, first out basis to avoid storage contamination that could adversely affect performance.

C. Chemical Exposure

Do not store cable receptacles near any chemical listed below as they may cause stress corrosion cracking in the contacts.

Alkalies	Ammonia	Citrates	Phosphates	Citrates	Sulfur Compounds
Amines	Carbonates	Nitrites	Sulfur	Nitrites	Tartrates

3.3. Panel

A. Thickness

The panel thickness range for the floating panel-mount cable receptacle shall be 0.79 through 2.54 [.031 through .100], and for the slide-to-lock cable receptacle, the panel thickness range shall be 1.02 ± 0.13 [.040 \pm .005].

B. Cutout

The panel must be cut using the dimensions provided on the customer drawing for the specific cable receptacle. Reference *samples* of recommended panel cutouts are shown in Figure 3.

Sample Recommended Panel Cutout

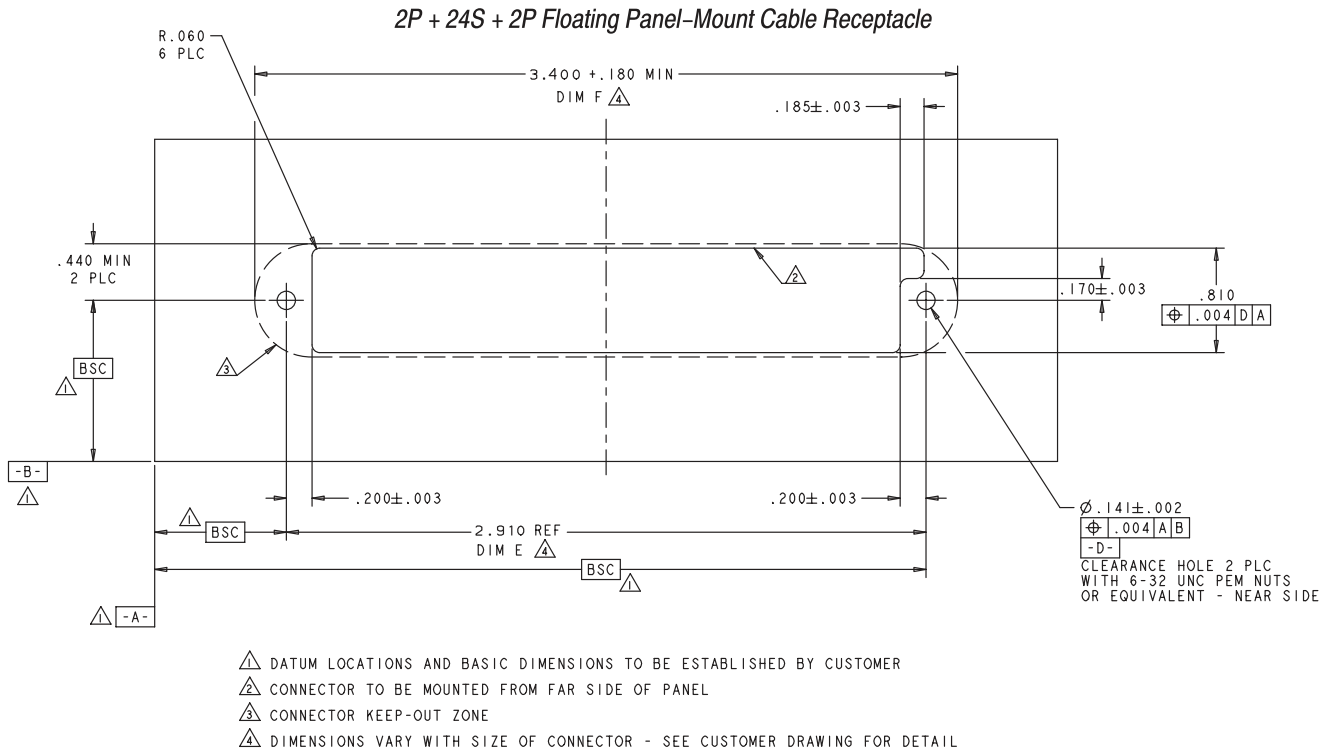

3 ACP Slide-to-Lock Cable Receptacle

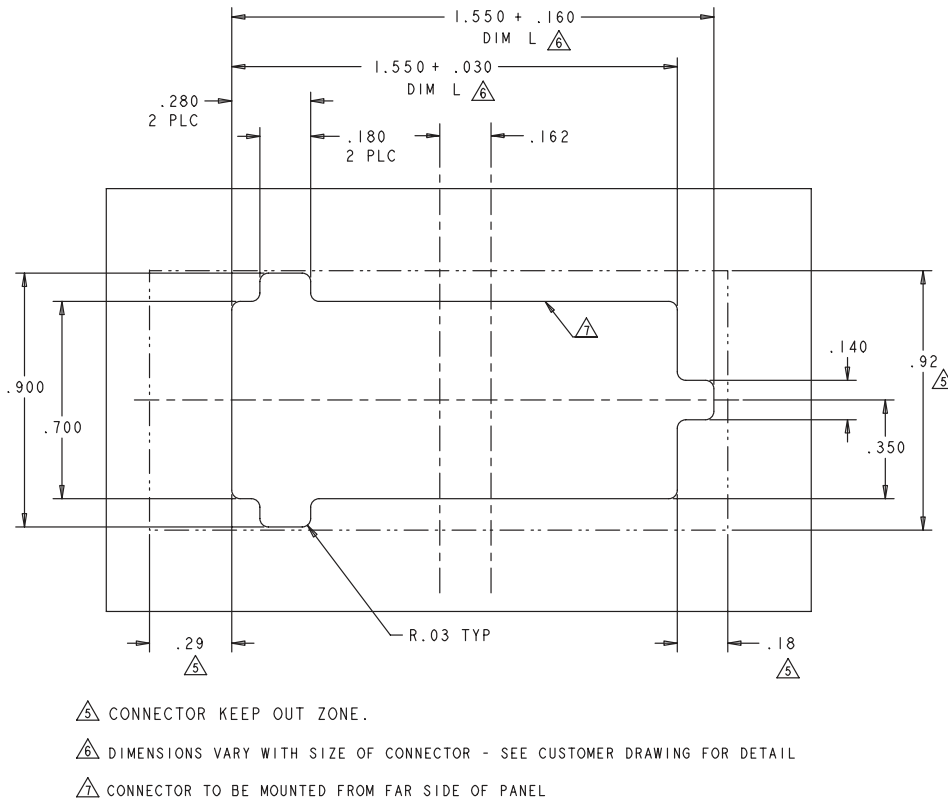

Figure 3

3.4. Panel Mounting

A. Floating Panel-Mount Cable Receptacle

The floating panel-mount cable receptacle is designed to be front or rear panel mounted using a panel mount hardware kit chosen according to the length of the connector (refer to customer drawing of specific cable receptacle for appropriate hardware kit part number). The hardware kit contains two shoulder screws, compression springs, and flat washers.

The receptacles are polarized to the panel by matching the panel alignment key(s) with the vertical notch(es) in the panel cutout. It is important to note that the receptacles can only be inserted into the panel opposite the cutting side. When secured to the panel, the floating panel-mount receptacle is designed to float in the panel cutout. This floating ability aids in alignment of mating connectors. The dimension of float is given in Figure 4.

When the cable receptacle is mounted, the shoulder of the screw must be bottomed on the panel. Refer to Figure 4.

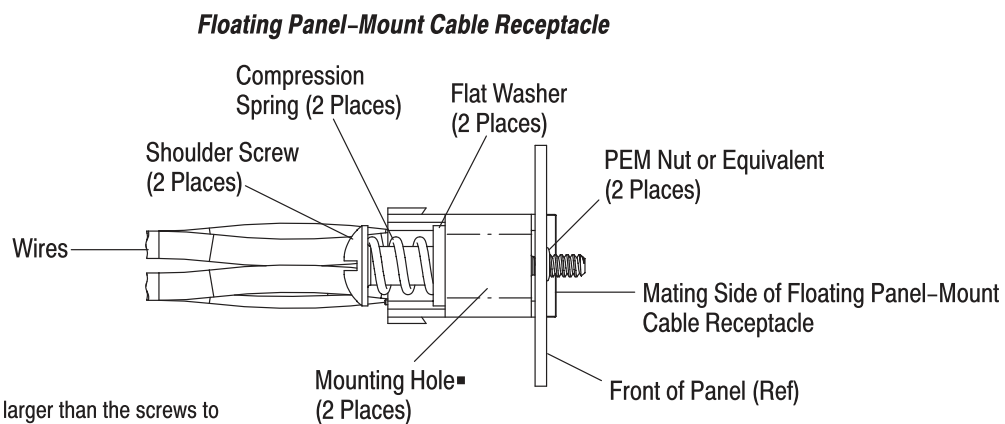

DIMENSION OF FLOAT (Nominal)

X and Y (Horizontal and Vertical)	Z (Back-and-Forth)	
	Standard Panel Mount Hardware Kit	High-Force Panel Mount Hardware Kit
$\pm 1.52 [\pm .060]$	$\pm 1.52 [\pm .060]$	$\pm 1.14 [\pm .045]$

Figure 4

B. Slide-to-Lock Cable Receptacle

The slide-to-lock cable receptacle is designed to be front or rear panel mounted without hardware. When secured to the panel, the slide-to-lock receptacle has a $\pm 0.76 [\pm .030]$ (nominal) X and Y (horizontal and vertical) float in the panel cutout. This floating ability aids in alignment of mating connectors.

Requirements of mounting the cable receptacle are as follows (refer to Figure 5):

1. The cable receptacle must be inserted through the panel until the panel stop is against the back of the panel.
2. The cable receptacle must be slid sideways toward the single-notched edge of the panel cutout until the locking tab “snaps” into place.
3. The locking tab must engage the panel, and the shoulder of the cable receptacle must be in front of the panel.

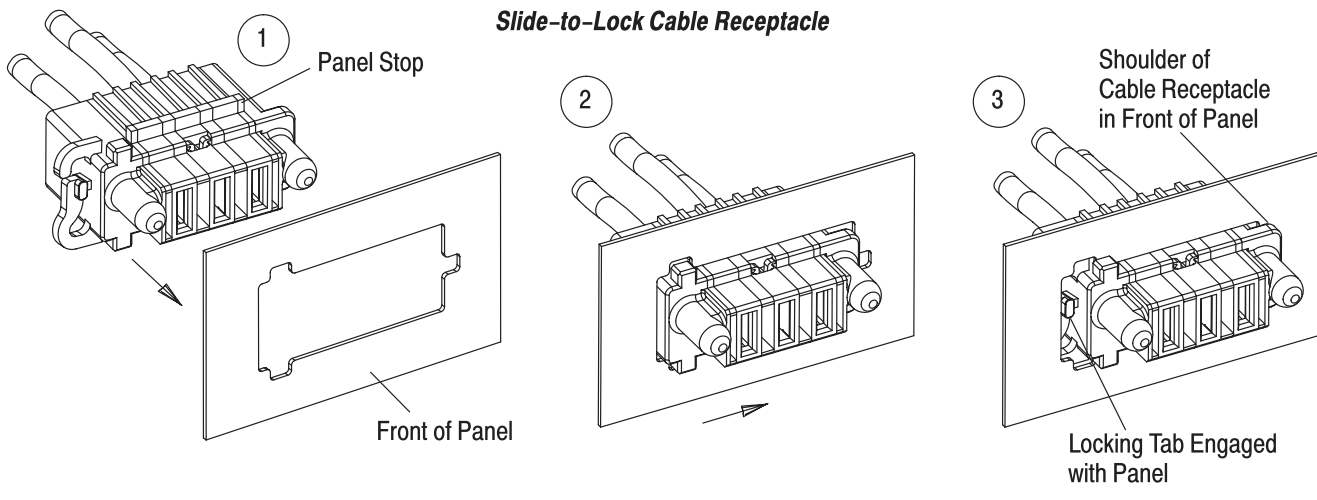

Figure 5

The mounted slide-to-lock cable receptacle must meet the dimension given in Figure 6.

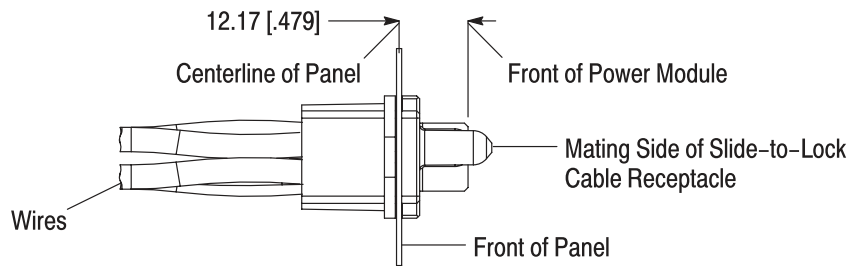

Figure 6

3.5. Mating

A. Polarization

For floating panel-mount and slide-to-lock cable receptacles, polarization is provided by matching the guide posts with the guide holes of mating connectors. For the squeeze-to-release cable receptacle, polarization is provided by matching the mating alignment keys with the key slots of mating connectors.

B. Mating Force

The average mating force per contact is given in Figure 7.

CONTACT	AVERAGE MATING FORCE PER CONTACT (N [oz])
Power	7.8 [28]
Signal	1.7 [6]

Figure 7

C. Mating Length

Contact mating lengths available for the connectors are listed in Figure 8.

CONTACT MATING LENGTH	
Power Contact	Signal Contact
MFBL (Pre-Mate)	Standard
Standard	

Figure 8

D. Wipe Length and Sequencing

Wipe length and sequencing for the connectors is given in 114-13038.

E. Misalignment

When mating connectors, the system is capable of aligning the receptacle to the header assembly when there is side-to-side and up-and-down misalignment to the dimensions given in Figure 9.

There is no alignment capability for the squeeze-to-release cable receptacle.

Misalignment for Floating Panel-Mount Cable Receptacle

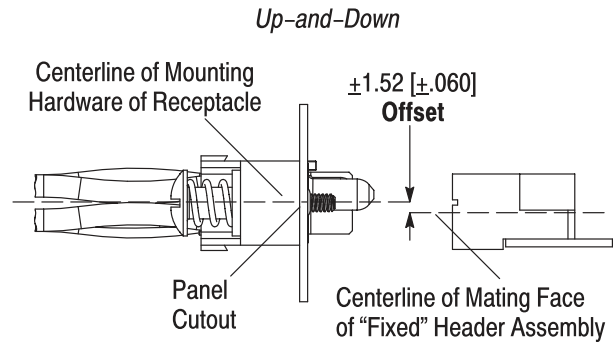
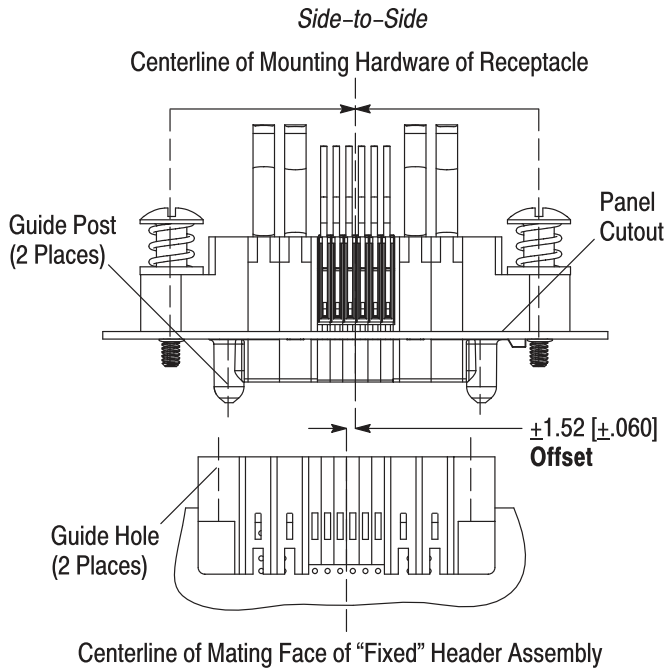

Note:

The system must be designed so that, during mating, the centerline of the receptacle mounting hardware is positioned relative to the centerline of the mating face of the header assembly within the dimensional **offset**. The allowable additional float of the receptacle can result in a dimensional maximum offset of 3.04 [.120] between the centerline of the guide posts of the receptacle and the centerline of the guides holes of the header assembly.

Misalignment for Slide-to-Lock Cable Receptacle

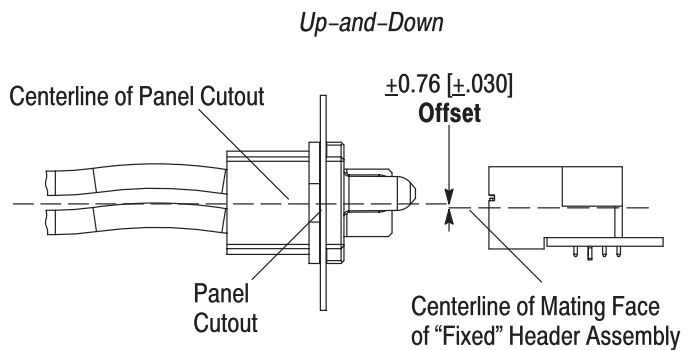
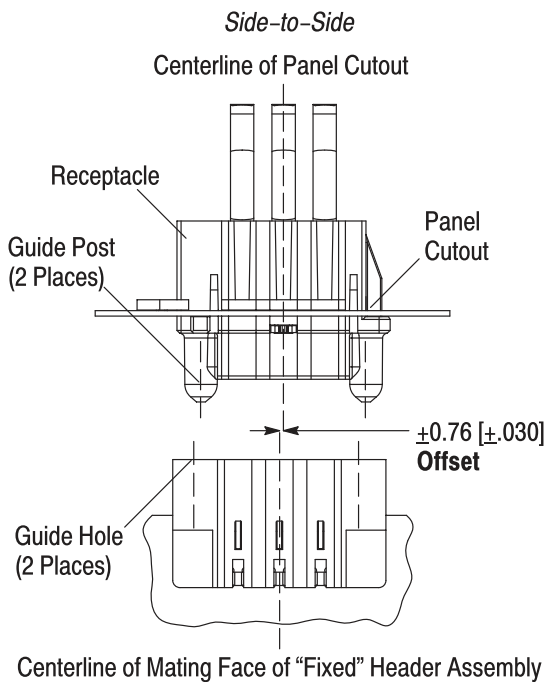

Note:

The system must be designed so that, during mating, the centerline of the receptacle panel cutout is positioned relative to the centerline of the mating face of the header assembly within the dimensional **offset**. The allowable additional float of the receptacle can result in a dimensional maximum offset of 1.52 [.060] between the centerline of the guide posts of the receptacle and the centerline of the guides holes of the header assembly.

Figure 9

F. Dimension

The required nominal mating dimension is provided in Figure 10.

Mating Dimension

Floating Panel-Mount Cable Receptacle

Mated to Right-Angle Header Assembly

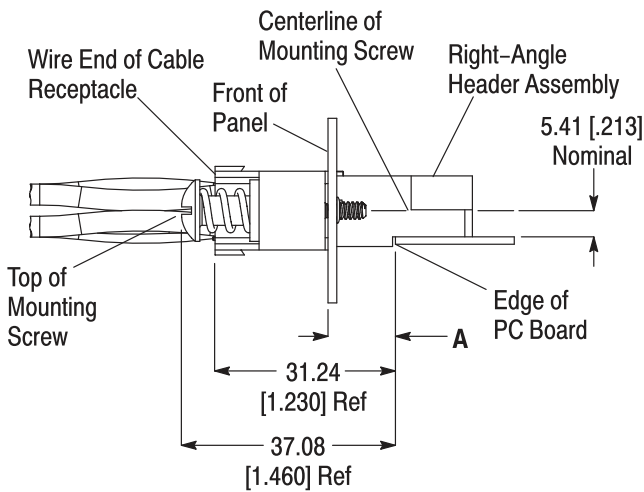

Mated to Vertical Header Assembly

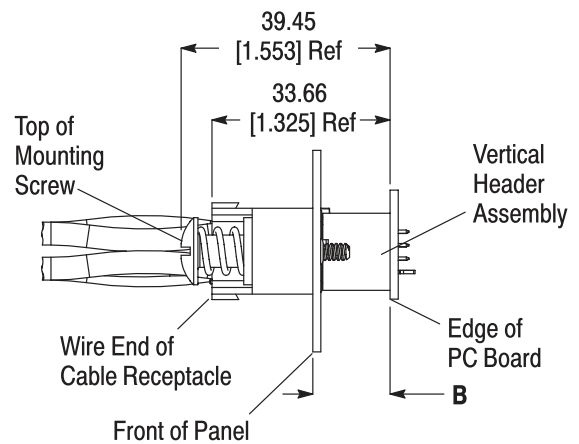

Slide-to-Lock Cable Receptacle

Mated to Right-Angle Header Assembly

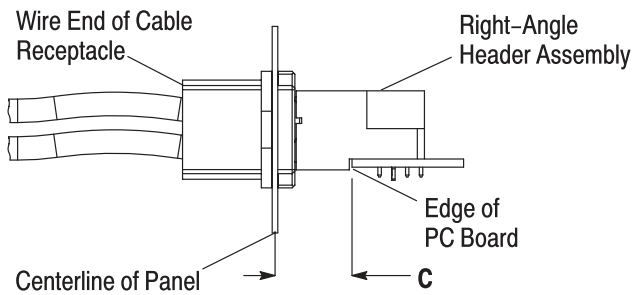

Mated to Vertical Header Assembly

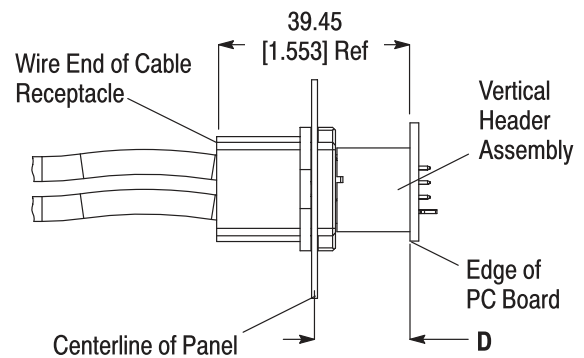

Squeeze-to-Release Cable Receptacle

Mated to Right-Angle Header Assembly

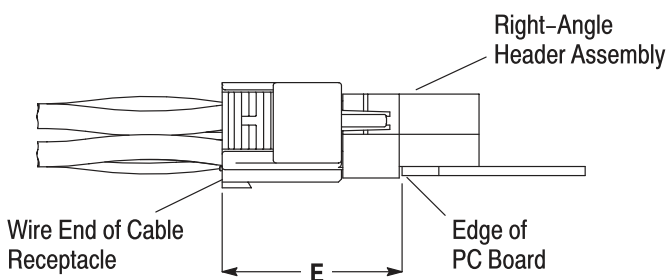

Mated to Vertical Header Assembly

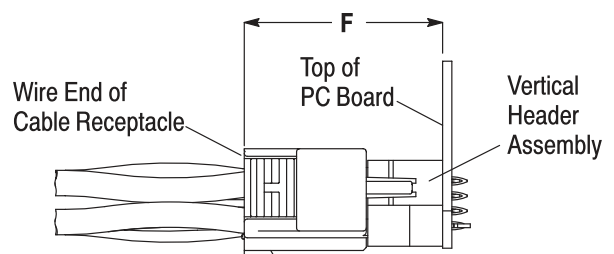

DIMENSION (Nominal)

A	B	C	D	E	F
12.19 [.480]	14.61 [.575]	14.19 [.559]	16.61 [.654]	31.24 [1.230]	39.45 [1.553]

Figure 10

3.6. Connector Unmating

The minimum amount of unmating force per contact is given in Figure 11.

CONTACT	MINIMUM UNMATING FORCE PER CONTACT (N [oz])
Power	2.22 [8]
Signal	0.19 [.7]

Figure 11

3.7. Removal from Panel

Connectors must be unmated before removal from panel.

A. Floating Panel-Mount Cable Receptacle

The mounting hardware must be loosened from the panel before the cable receptacle can be removed from the panel.

B. Slide-to-Lock Cable Receptacle

The locking tab of the cable receptacle must be disengaged from the panel, then the cable receptacle slid sideways away from the single-notched edge of the panel cutout. The panel alignment keys must align with the vertical notches in the panel cutout before the cable receptacle can be removed from the panel. Refer to Figure 12.

Removing Slide-to-Lock Cable Receptacle from Panel

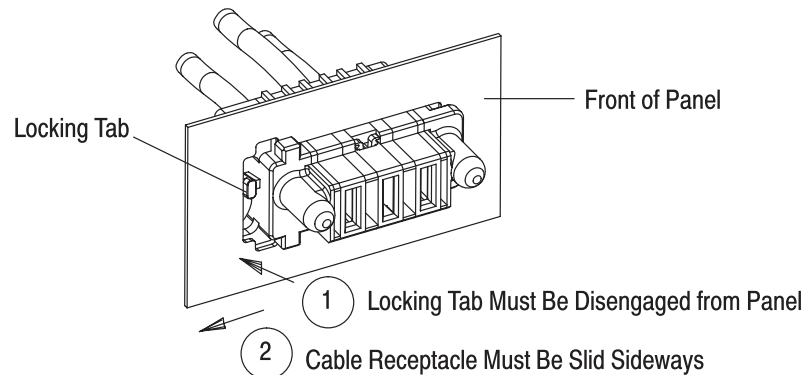

Figure 12

3.8. Repair

Damaged or defective cable receptacles must not be used. Wires **MUST NOT** be removed from the connector.

4. QUALIFICATION

Multi-Beam XL cable receptacle assemblies have been submitted for UL and CSA International evaluation.

5. TOOLING

A No. 3 cross-recessed screwdriver can be used to install the hardware for securing the floating panel-mount cable receptacle to the panel.

6. VISUAL AID

The illustration below shows a typical application of Multi-Beam XL cable receptacle assemblies. This illustration should be used by production personnel to ensure a correctly applied product. Applications which DO NOT appear correct should be inspected using the information in the preceding pages of this specification and in the instructional material shipped with the product or tooling.

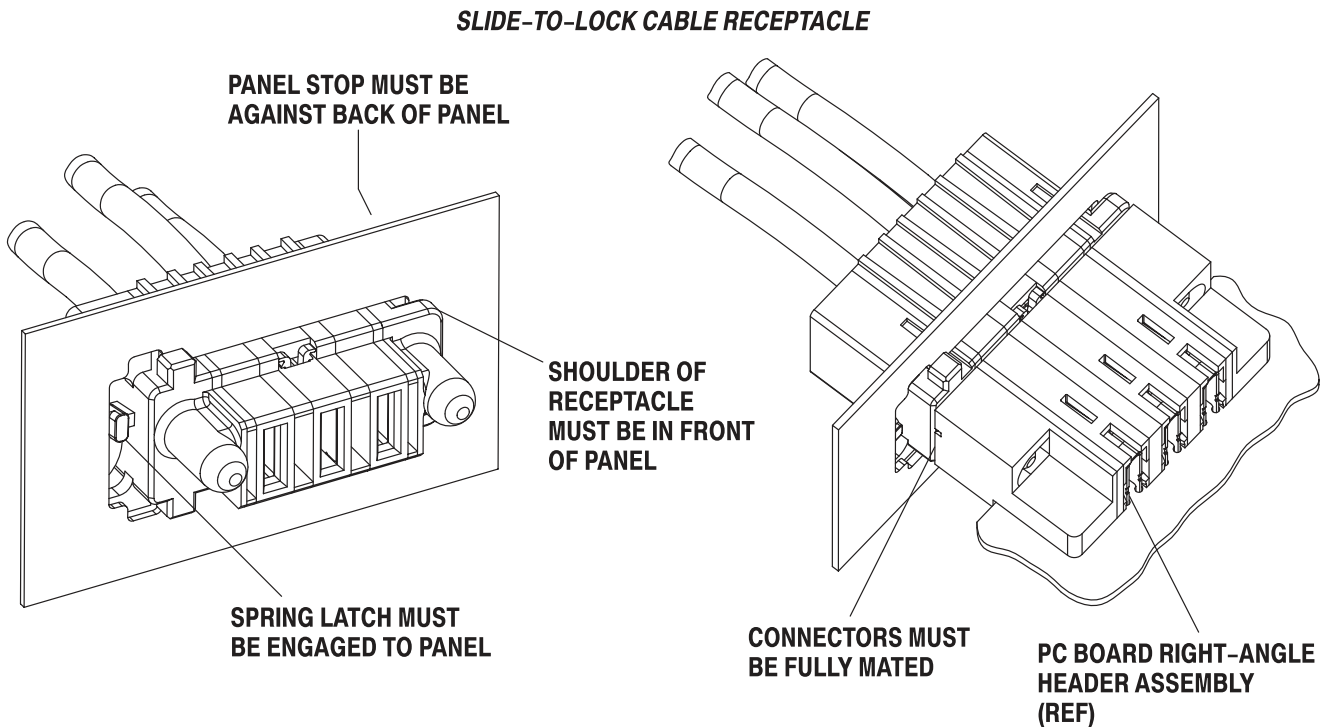
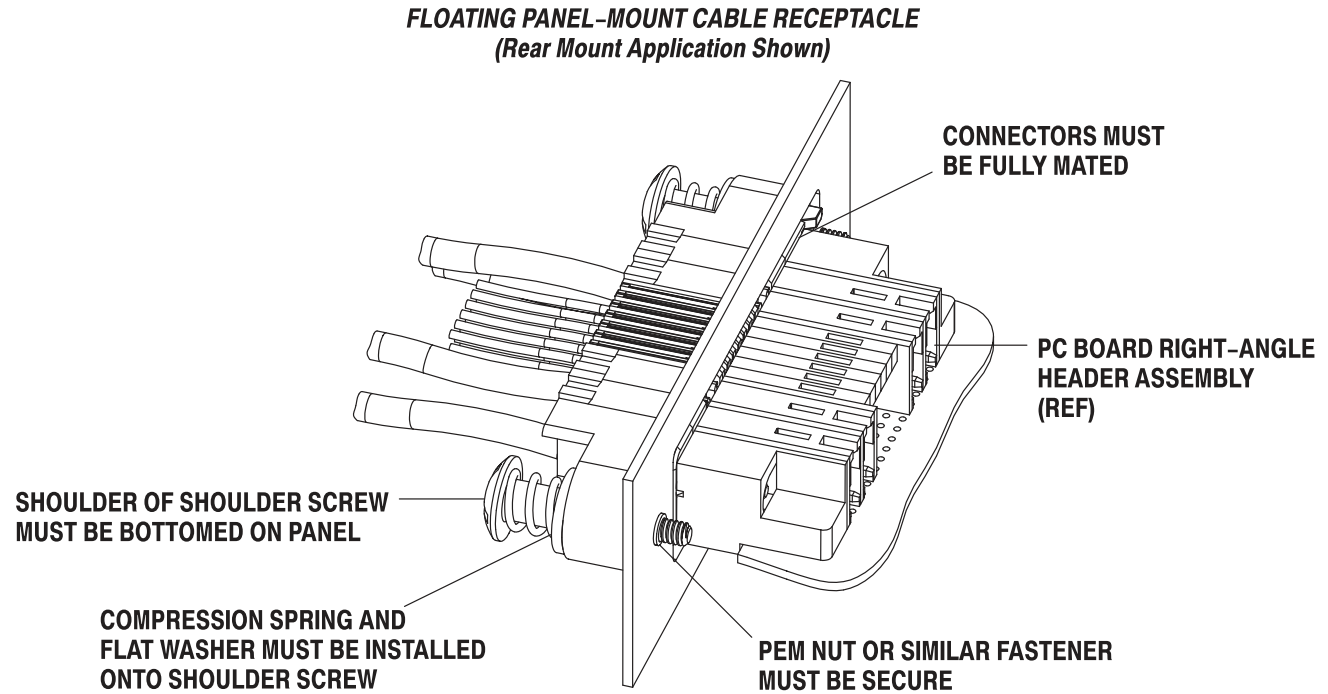

FIGURE 13. VISUAL AID (CONT'D)

SQUEEZE-TO-RELEASE CABLE RECEPTACLE

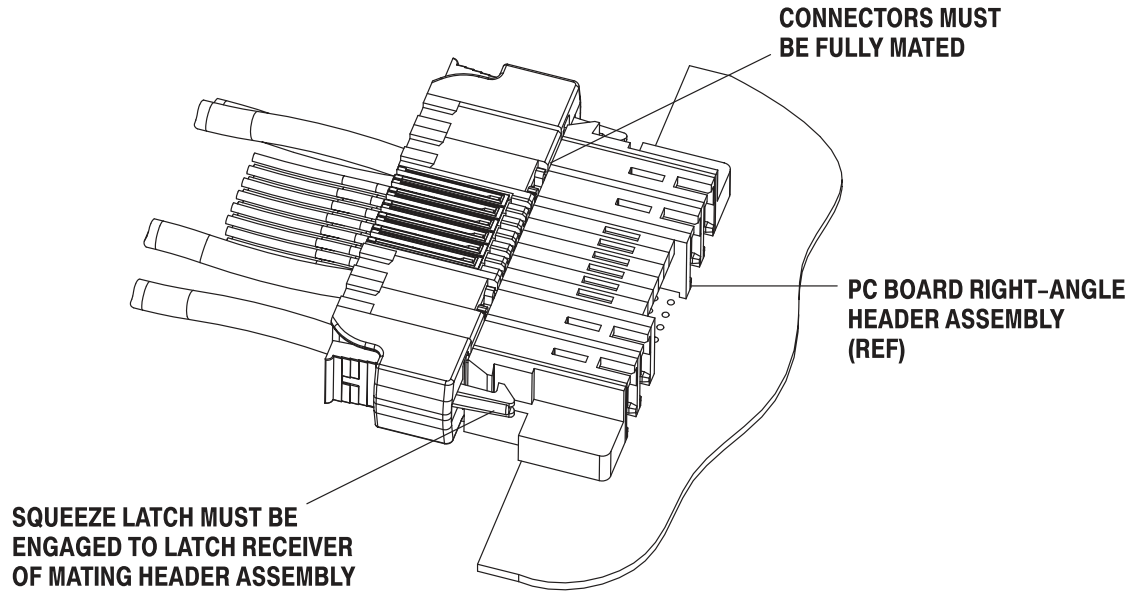

FIGURE 13. VISUAL AID (END)