

# LCD Adapter™

## Manual

*All Mikroelektronika's development systems feature a large number of peripheral modules expanding microcontroller's range of application and making the process of program testing easier. In addition to these modules, it is also possible to use numerous additional modules linked to the development system through the I/O port connectors. Some of these additional modules can operate as stand-alone devices without being connected to the microcontroller.*

# Additional Board

 **MikroElektronika**

SOFTWARE AND HARDWARE SOLUTIONS FOR EMBEDDED WORLD ...making it simple

## LCD Adapter Additional Board

The *LCD Adapter* additional board is used to connect the pins of the microcontroller provided on the development system to a 2x16 LCD or a 4x20 LCD. The additional board is connected to a development system via a 2x5 female connector provided on the flat cable, whereas a 1x16 male connector provided on the additional board enables connection with an LCD display. In addition to this connector, there is also a potentiometer used for the display backlight regulation provided on the board.

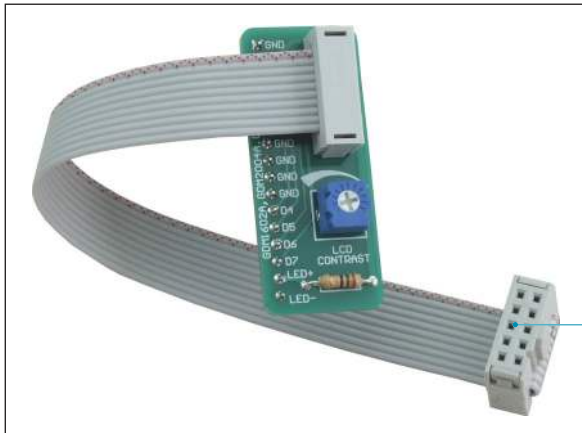

Figure 1: LCD Adapter additional board

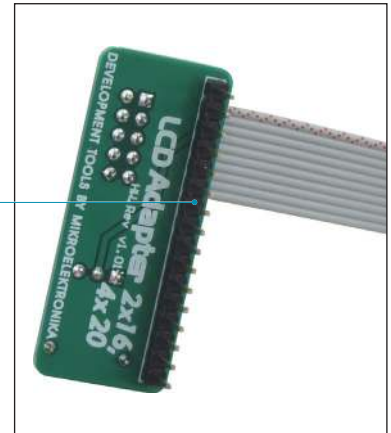

Figure 2: LCD Adapter board's back view

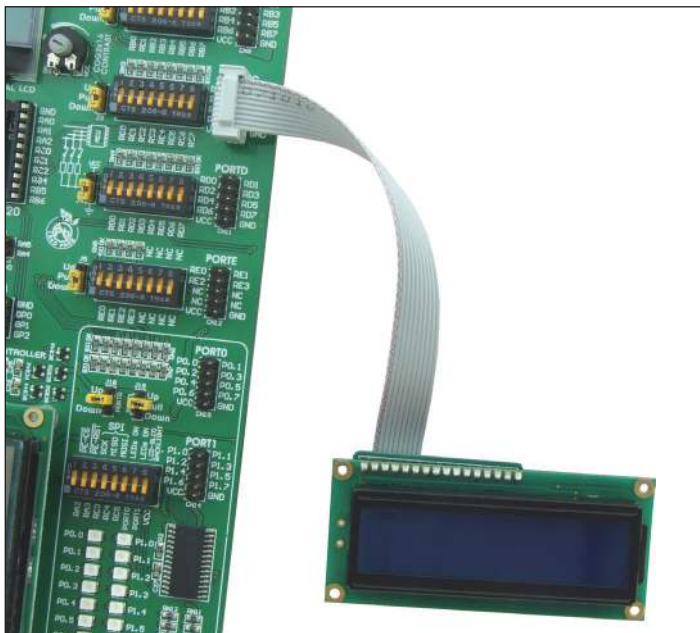

Figure 3: LCD Adapter additional board connected to a development system

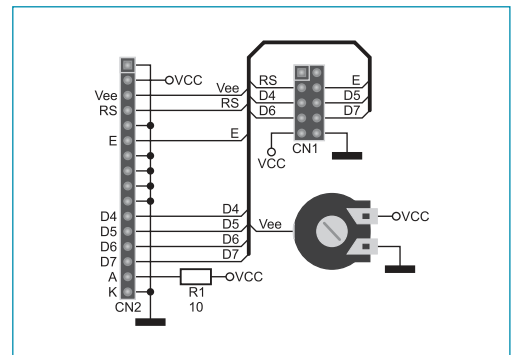

Figure 4: LCD Adapter additional board connection schematic





**MikroElektronika**  
SOFTWARE AND HARDWARE SOLUTIONS FOR EMBEDDED WORLD ...making it simple

If you want to learn more about our products, please visit our website at [www.mikroe.com](http://www.mikroe.com)

If you are experiencing some problems with any of our products or just need additional information, please place your ticket at [www.mikroe.com/en/support](http://www.mikroe.com/en/support)

If you have any questions, comments or business proposals, do not hesitate to contact us at [office@mikroe.com](mailto:office@mikroe.com)