

PART NO.	JLL-301 WIRE	SCALE	1: 1
DESCRIPTION	SJT#16*3C 60C	UNIT:	mm
DWG No.	CNC-99-16		

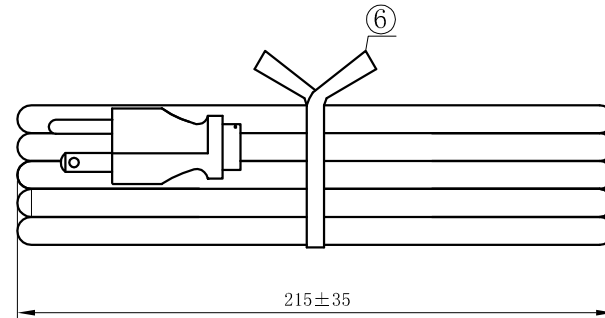

NOTES:

- 1) JACKET COLOR: BLACK
- 2). E-GREEN; L-BLACK ; N-WHITE

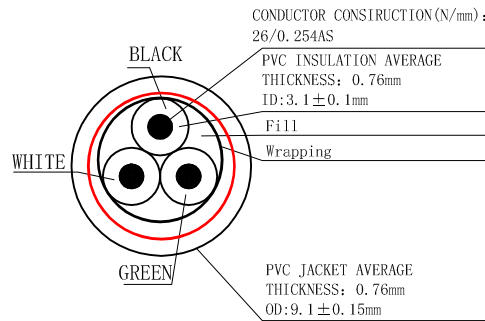
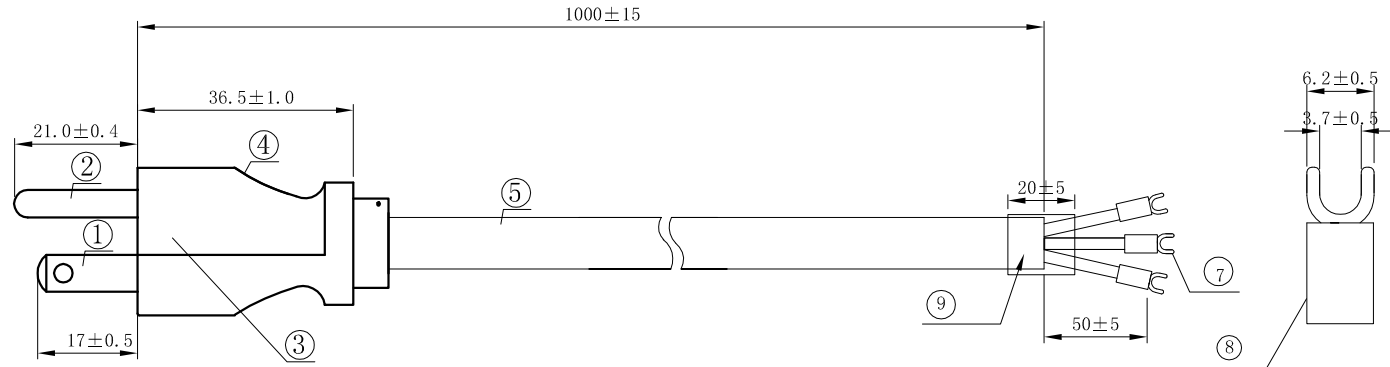
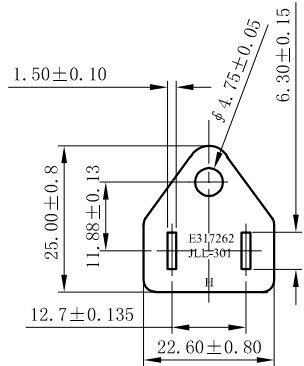

NO.	SPECIFICATION	COLOUR	MATERIAL	AMOUNT
①	Load terminals 98661	Silver	Cu	2P
②	Grounding terminal 97475	Silver	Cu	1P
③	Model aircraft 8661AN-3P	WHITE	PBT	1PCS
④	Plug JLL-301	BLACK	PVC Cu	1PCS
⑤	Wire SJT 16AWG/3C 60°C	BLACK	PVC Cu	1PCS
⑥	Ties	BLACK		1PCS
⑦	Solutions Terminal		Brass Tin/plated	3PCS
⑧	InsulateColour	BLUE		
⑨	Adhesive lined heat Shrink tube	BLACK		1PCS

Printing the contents of wire      The use of printing ink replenish Wire

E243711 (UL) SJT 3×16AWG(1.31mm<sup>2</sup>) VW-1 60°C 300V  
CSA 228191 SJT 3×16AWG(1.31mm<sup>2</sup>) FT2 60°C 300V -LF-

REV	DATE	DESCRIPTION	SYMBOL
	DRAWN/DATE	CHECKED/DATE	
	CAI/12.02.29	GONG/12.02.29	