

REVISIONS			
REV	DESCRIPTION, ECN, EAR NO.	DATE	APP'D
K	PRODUCT DRAWING (EAR 15230)	JAN9/23	K.L.
L	PRODUCT DRAWING (EAR 15304)	AUG22/23	K.L.

**ORDERING CODE: ND9-AS1X-00**

- SERIES, IX INDUSTRIAL
- A KEY FOR ETHERNET
- SOCKET / RECEPTACLE
- RIGHT ANGLE FLAG STYLE
- PLATING FOR MATING AREA
  - 1 = GOLD FLASH
  - 2 = 0.20µm (8µ") GOLD
  - 3 = 0.76µm (30µ") GOLD
  - 4 = 1.27µm (50µ") GOLD
  - 7 = 0.76µm (30µ") PALLADIUM NICKEL WITH GOLD FLASH
- STANDARD

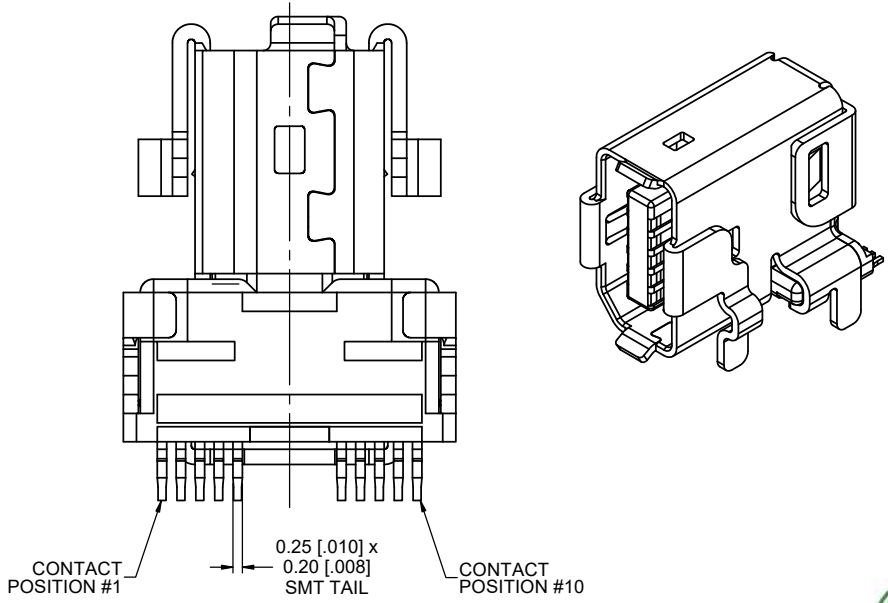

**NOTES:**

- MATERIAL: RoHS COMPLIANT PER EU DIRECTIVE 2011/65/EU AND AMENDMENTS.
  - SHIELD: STAINLESS STEEL, MATTE TIN OVER NICKEL PLATED.
  - INSERTS: HIGH TEMPERATURE RESISTANT ENGINEERING THERMOPLASTIC, GLASS REINFORCED, UL94V-0, BLACK.
  - CONTACTS: COPPER ALLOY PLATED WITH GOLD OR PALLADIUM-NICKEL (SEE ORDERING CODE) OVER 1.27µm (50µ") MINIMUM NICKEL ON THE MATING AREA AND GOLD FLASH OVER NICKEL ON THE SMT TAILS. CODE 4 MATING AREA PLATING 1.27µm (50µ") GOLD OPTION CONFORMS TO ASTM B488, TYPE 2, CODE C, CLASS 1.25.
  - MID-PLATE: STAINLESS-STEEL
- CONNECTORS ARE PROVIDED IN TAPE & REEL PACKAGING FOR PICK & PLACE PROCESSING AND ARE SUITABLE FOR IR REFLOW SOLDERING OF PIN IN PASTE SHIELD TAILS AND SURFACE MOUNT CONTACT TAILS.
- DESIGNED TO CONFORM TO REQUIREMENTS OF IEC 61076 PART 3-124 SPECIFICATION. THE A KEY FEATURE SHOWN IS INTENDED FOR USE WITH ETHERNET APPLICATIONS, EITHER 10/100 MBIT/S OR 1 TO 10 GBIT/S (CAT 5e, 6 & 6A).
- CURRENT RATING: 1.5 AMPERES, VOLTAGE RATING: 50V AC rms OR 60V DC
- OPERATING TEMPERATURE -55° TO +105°C.
- DIELECTRIC WITHSTANDING VOLTAGE: 500V DC
- CONTACT RESISTANCE: 30 MILLIOHMS MAXIMUM.
- INSULATION RESISTANCE: 500 MEGOHMS MINIMUM.
- MATING & UNMATING FORCE: 25N (5.6 lbf) MAXIMUM.



UNLESS SPECIFIED OTHERWISE	DRAWN	B.COPPING	MAR5/19
PRIMARY UNITS MILLIMETRES	CHECKED	K. LAMBIE	MAR5/19
SECONDARY INCHES	M.E. APP'D		
REFERENCE IN PARENTHESES	Q.A. APP'D		
GENERAL TOLERANCES	DWG APPR.		
1 DECIMAL PLACE	ENG. REL. NO.	EAR 14720	
2 DECIMAL PLACES ±0.15	REF.		
3 DECIMAL PLACES	THIRD ANGLE PROJECTION		
ANGULAR DEGREES	DO NOT SCALE DRAWING		

**Amphenol Canada Corp.**  
Commercial Products

**IX INDUSTRIAL CONNECTOR, 10 POSITION  
A KEY RIGHT ANGLE FLAG STYLE,  
SMT TERMINATION, CAT 6A HIGH SPEED  
PERFORMANCE, RoHS COMPLIANT**

DWG. NO. **P-ND9-AS1X-00** REV **L**

CODE ID NO. 03554 DWG SIZE: X SCALE: 10:1 SHEET 1 OF 3

REVISIONS			
REV	DESCRIPTION, ECN, EAR NO.	DATE	APP'D
K	PRODUCT DRAWING (EAR 15230)	JAN9/23	K.L.
L	PRODUCT DRAWING (EAR 15304)	AUG22/23	K.L.

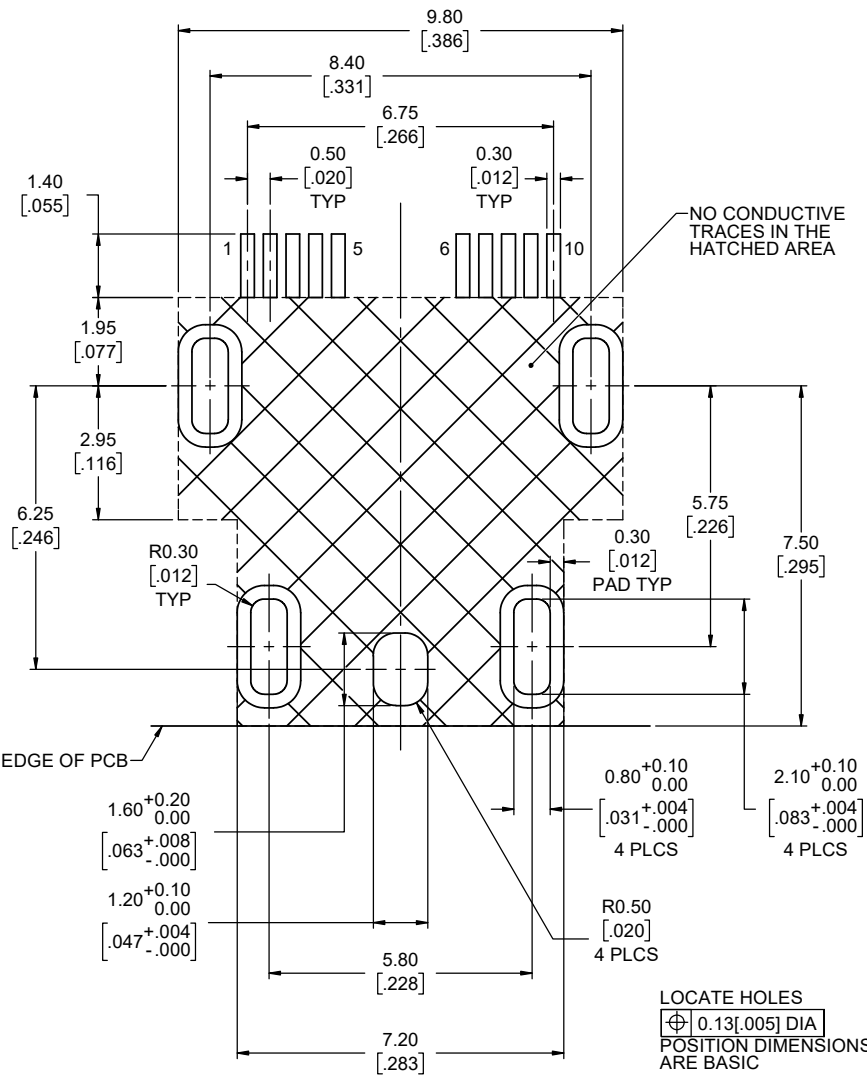

**RECOMMENDED PCB LAYOUT**  
 COMPONENT SIDE OF BOARD  
 SCALE 12:1  
 GENERAL TOLERANCE  $\pm 0.05$ mm  
 FOR THIS VIEW

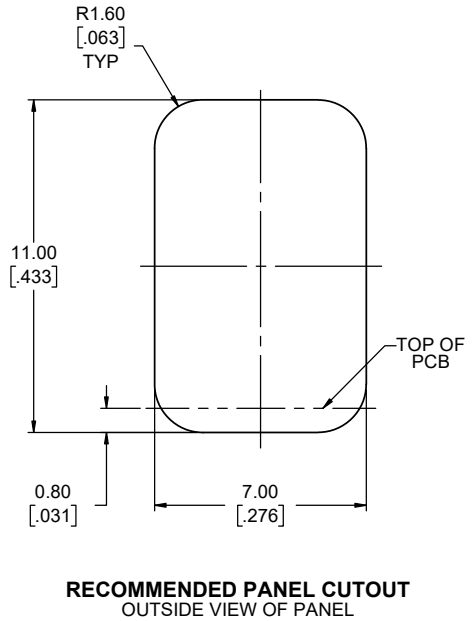
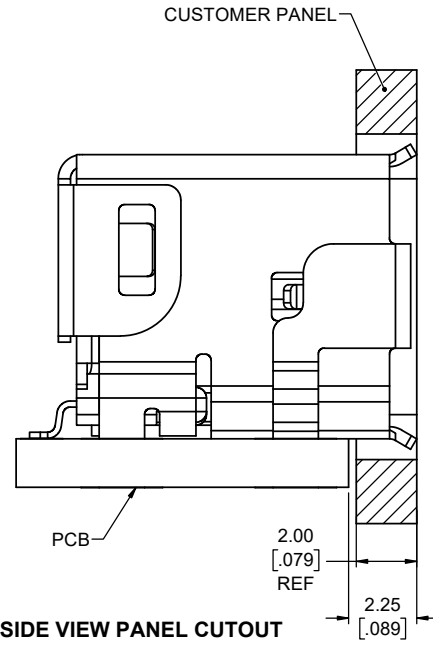

CONNECTOR PIN ASSIGNMENT		
POSITION NUMBER	PIN ASSIGNMENT 10 OR 100 Mbit/S ETHERNET	PIN ASSIGNMENT 1, 2.5, 5 OR 10 Gbit/S ETHERNET
1	TX +	BI_DA +
2	TX -	BI_DA -
3	NOT USED	GND
4	NOT USED	BI_DC +
5	NOT USED	BI_DC -
6	RX +	BI_DB +
7	RX -	BI_DB -
8	NOT USED	GND
9	NOT USED	BI_DD +
10	NOT USED	BI_DD -

UNLESS SPECIFIED OTHERWISE	DRAWN	B.COPPING	MAR5/19
PRIMARY UNITS MILLIMETRES	CHECKED	K. LAMBIE	MAR5/19
SECONDARY INCHES	M.E. APP'D		
REFERENCE IN PARENTHESES	Q.A. APP'D		
GENERAL TOLERANCES	DWG APPR.		
1 DECIMAL PLACE	ENG. REL. NO.	EAR 14720	
2 DECIMAL PLACES $\pm 0.15$	REF.		
3 DECIMAL PLACES	THIRD ANGLE PROJECTION		
ANGULAR DEGREES		DO NOT SCALE DRAWING	

**Amphenol Canada Corp.**  
 Commercial Products

**IX INDUSTRIAL CONNECTOR, 10 POSITION**  
 A KEY RIGHT ANGLE FLAG STYLE,  
 SMT TERMINATION, CAT 6A HIGH SPEED  
 PERFORMANCE, RoHS COMPLIANT

DWG. NO. **P-ND9-AS1X-00** REV **L**

CODE ID NO. 03554 DWG SIZE: X SCALE: 8:1 SHEET 2 OF 3

REVISIONS			
REV	DESCRIPTION, ECN, EAR NO.	DATE	APP'D
K	PRODUCT DRAWING (EAR 15230)	JAN9/23	K.L.
L	PRODUCT DRAWING (EAR 15304)	AUG22/23	K.L.

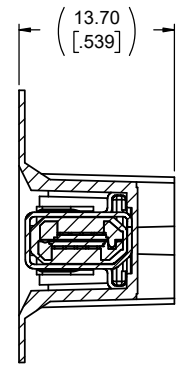
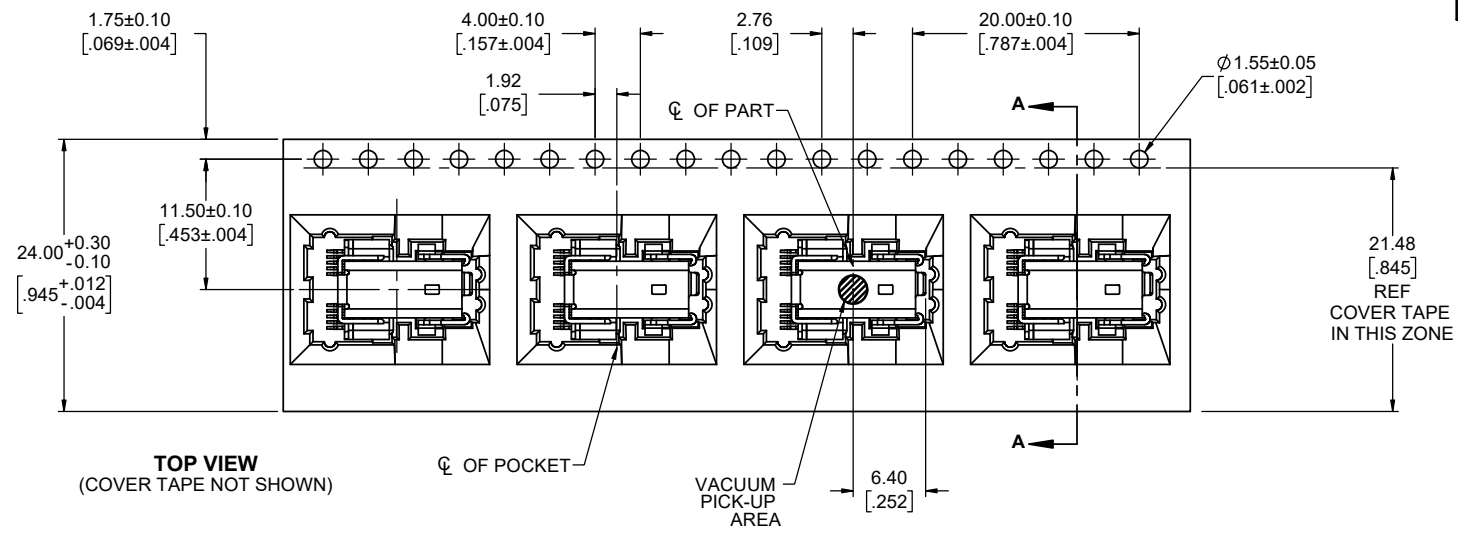

**SECTION A-A**  
SCALE 3 : 1

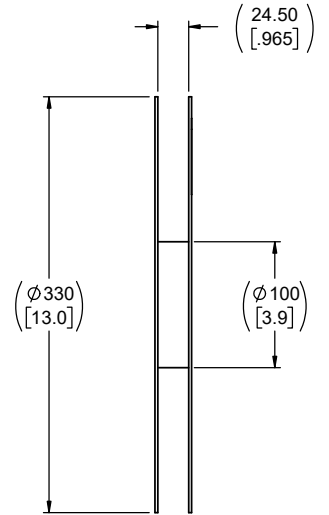
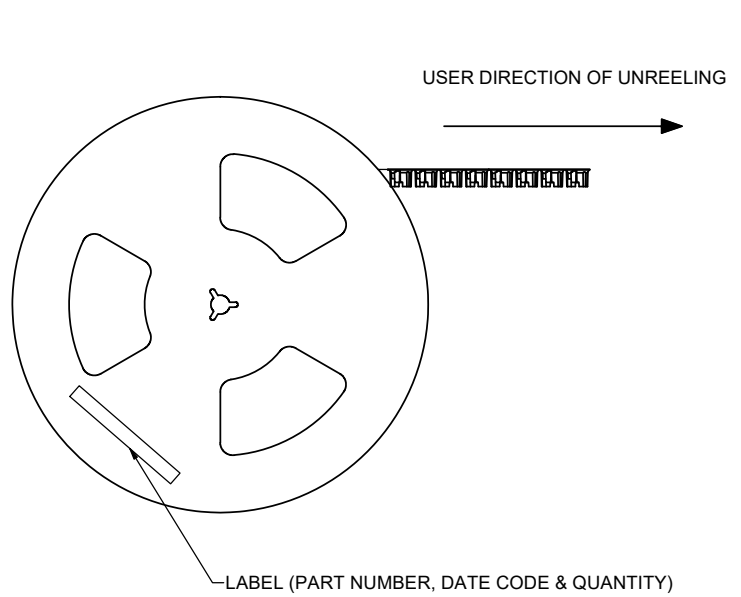

**PACKAGING NOTES:**

1. EACH REEL TO CONTAIN A QUANTITY OF 240 CONNECTORS.
2. EACH FULL CARTON TO CONTAIN A QUANTITY OF 9 REELS TOTAL OF 2160 CONNECTORS.

THIS DOCUMENT CONTAINS PROPRIETARY INFORMATION AND SUCH INFORMATION MAY NOT BE DISCLOSED TO OTHERS FOR ANY PURPOSE OR USED FOR MANUFACTURING PURPOSES WITHOUT WRITTEN PERMISSION FROM AMPHENOL CANADA CORP.

UNLESS SPECIFIED OTHERWISE	DRAWN	B.COPPING	MAR5/19
PRIMARY UNITS MILLIMETRES	CHECKED	K.LAMBIE	MAR5/19
SECONDARY UNITS INCHES	M.E. APP'D		
REFERENCE IN PARENTHESES	Q.A. APP'D		
GENERAL TOLERANCES	DWG APPR.		
1 DECIMAL PLACE	ENG. REL. NO.	EAR 14720	
2 DECIMAL PLACES	REF.		
3 DECIMAL PLACES	THIRD ANGLE PROJECTION		
ANGULAR DEGREES			

**Amphenol Canada Corp.**  
Commercial Products

**IX INDUSTRIAL CONNECTOR, 10 POSITION  
A KEY RIGHT ANGLE FLAG STYLE,  
SMT TERMINATION, CAT 6A HIGH SPEED  
PERFORMANCE, RoHS COMPLIANT**

DWG. NO. **P-ND9-AS1X-00** REV **L**

CODE ID NO. 03554 DWG SIZE: X SCALE: 3:1 SHEET 3 OF 3