

LOC GT	DIST -	REVISIONS				
P	LTR	DESCRIPTION	DATE	DWN	APVD	
	A2	SEE ECR-12-005245	20MAR12	MP	VC	

WIRE BARREL

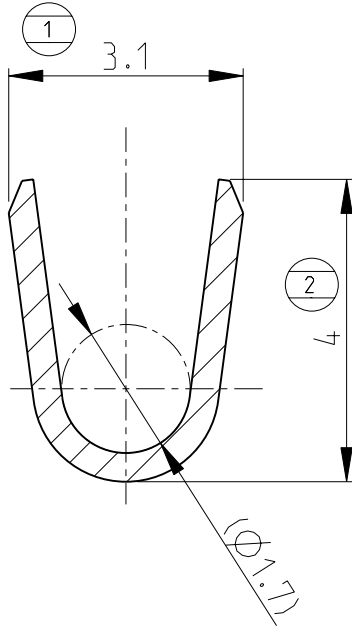

INSULATION BARREL

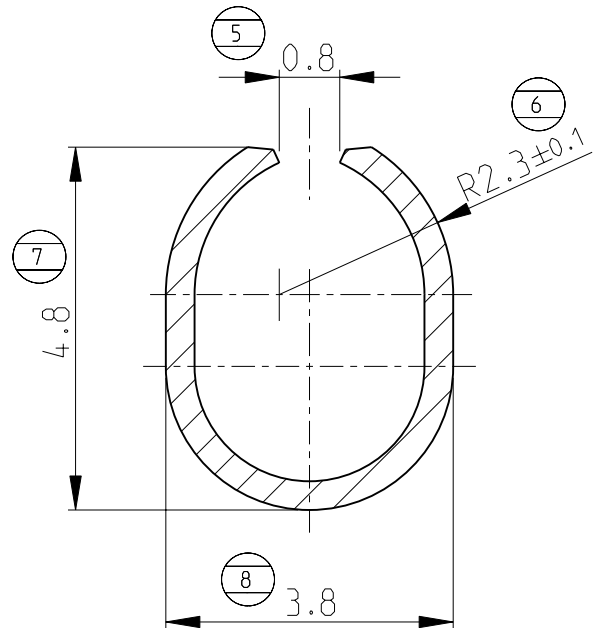

NOTES:

- 1 MISSING DIMENSIONS SEE DRAWING OF STRIP FORM PN 964133
- 2 CUT OFF TAB MAX. 0.5mm
- 3 FOR USE WITH CRIMP HANDTOOL PN 539635-1 WITH CRIMPING HEAD PN 539734-2
- 4 CRIMP PRE-FORMED

0-964133-4	SEL. GOLD PLATED	CuSn4	0-964142-4	FOR CURRENT REVISION SEE STRIP-DRAW.
0-964133-3	PRETINNED	CuNiSi	0-964142-3	
0-964133-2	PRETINNED	CuSn4	0-964142-2	
0-964133-1	PLAIN	CuSn4	0-964142-1	
MADE FROM (STRIP)	FINISH	MATERIAL	LP NO	REV

DIMENSIONS: mm	DWN M. Pavlicek	26MAR2012	MATERIAL	SEE TABLE	FINISH	-
	CHK M. Benes	27MAR2012	TE Connectivity			
TOLERANCES UNLESS OTHERWISE SPECIFIED:	APVD V. Cech	28MAR2012				
0 PLC ± 1 PLC ± 2 PLC ± 3 PLC ± 4 PLC ± ANGLES ±2°	PRODUCT SPEC	-	SIZE	CAGE CODE	DRAWING NO	RESTRICTED TO
	APPLICATION SPEC	114-18014	A 4	00779	©-964142	-
	WEIGHT	-	CUSTOMER DRAWING			SCALE 10:1
					SHEET 1 OF 1	REV A2

2012

RELEASED FOR PUBLICATION

ALL RIGHTS RESERVED.

Tyco Electronics AMP GmbH

COPYRIGHT 2012

THIS DRAWING IS UNPUBLISHED.