

THIS DRAWING IS UNPUBLISHED. RELEASED FOR PUBLICATION 20
 © COPYRIGHT 20 BY - ALL RIGHTS RESERVED.

REVISIONS					
P	LTR	DESCRIPTION	DATE	DWN	APVD
A		RELEASE	01NOV2016	JY	SH
A1		REVISED PER ECN-22-163746	11JUL2022	IT	SZ

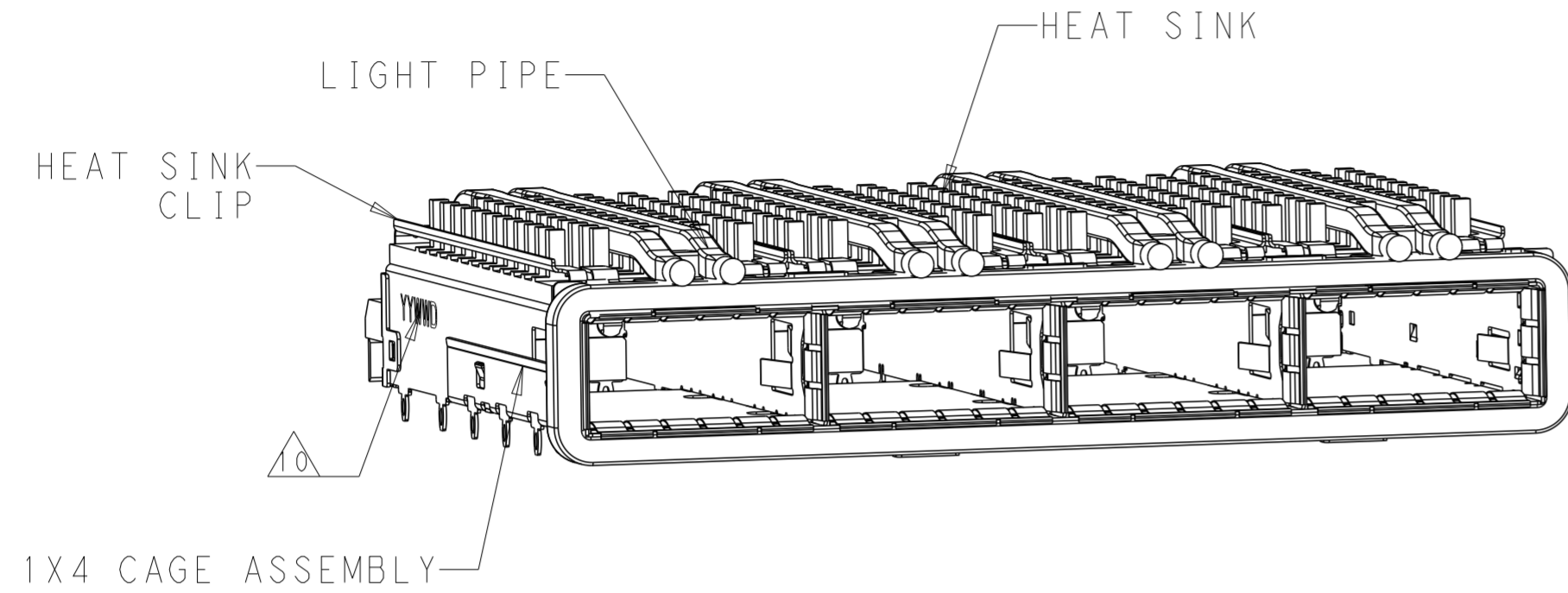

- COMPONENTS
 CAGE ASSEMBLY: NICKEL-SILVER ALLOY
 HEAT SINK: ALUMINUM/BLACK ANODIZE
 HEAT SINK CLIP: STAINLESS STEEL
 EMI SPRING: COPPER ALLOY/NICKEL PLATE
 EMI GASKET: PLATED FILLED SILICONE
 LIGHT PIPE: CLEAR POLYCARBONATE WITH 94 V-0
 ORGANIZER: POLYESTER WITH UL 94 V-0
- REFERENCE APPLICATION SPECIFICATION 114-32023 FOR RECOMMENDED DRILL HOLE DIAMETER AND PLATING THICKNESS
- DATUM AND BASIC DIMENSION ESTABLISHED BY CUSTOMER
- DIMENSION APPLIES WITH MODULE INSERTED IN CAGE
- HEAT SINKS, HEAT SINK CLIPS AND LIGHT PIPES ARE SHIPPED ASSEMBLED ON CAGE
- MINIMUM PC BOARD THICKNESS: SINGLE SIDED: 1.57 MIN
DOUBLE SIDED: 3.00 MIN
- DATUM **-A-** IS TOP SURFACE OF THE HOST BOARD.
- THESE HOLES ARE OPTIONAL WHEN THE REAR PINS ARE REMOVED.
- MATES WITH QSFP28 MSA COMPATIBLE TRANSCEIVER.
- DATE CODE (YYWWD) MARKED APPROXIMATELY AS SHOWN.

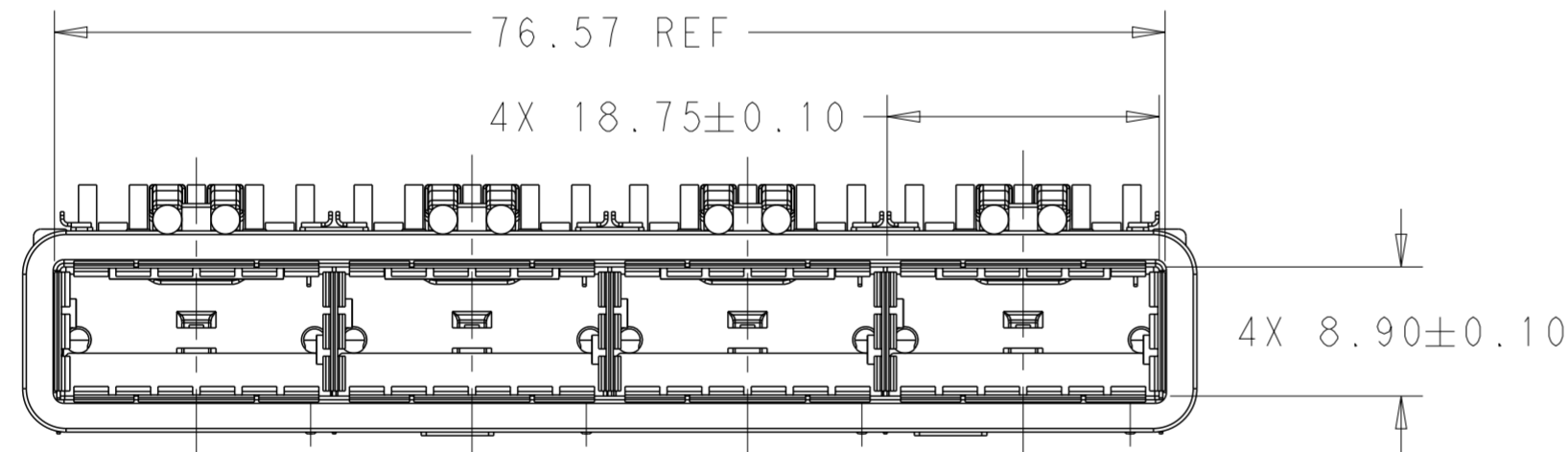

SCALE 2:1

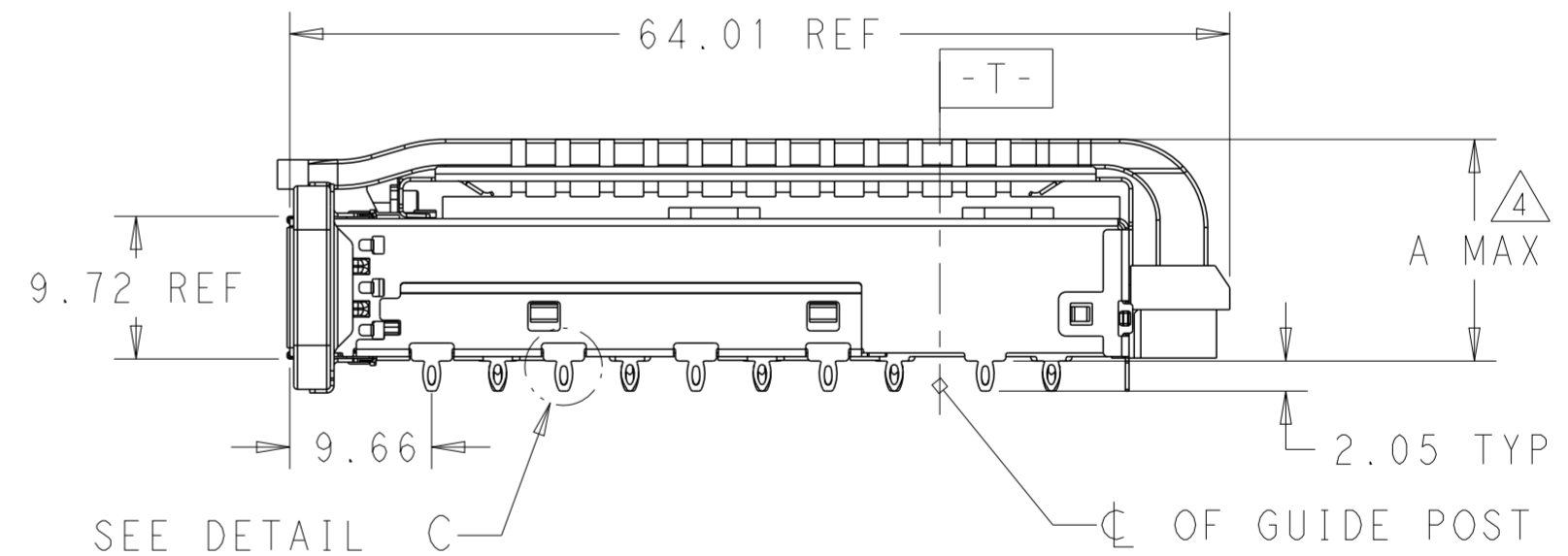

SEE DETAIL C

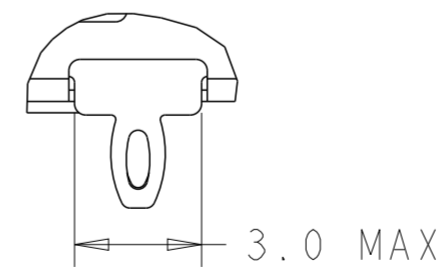

DETAIL C
SCALE 6:1

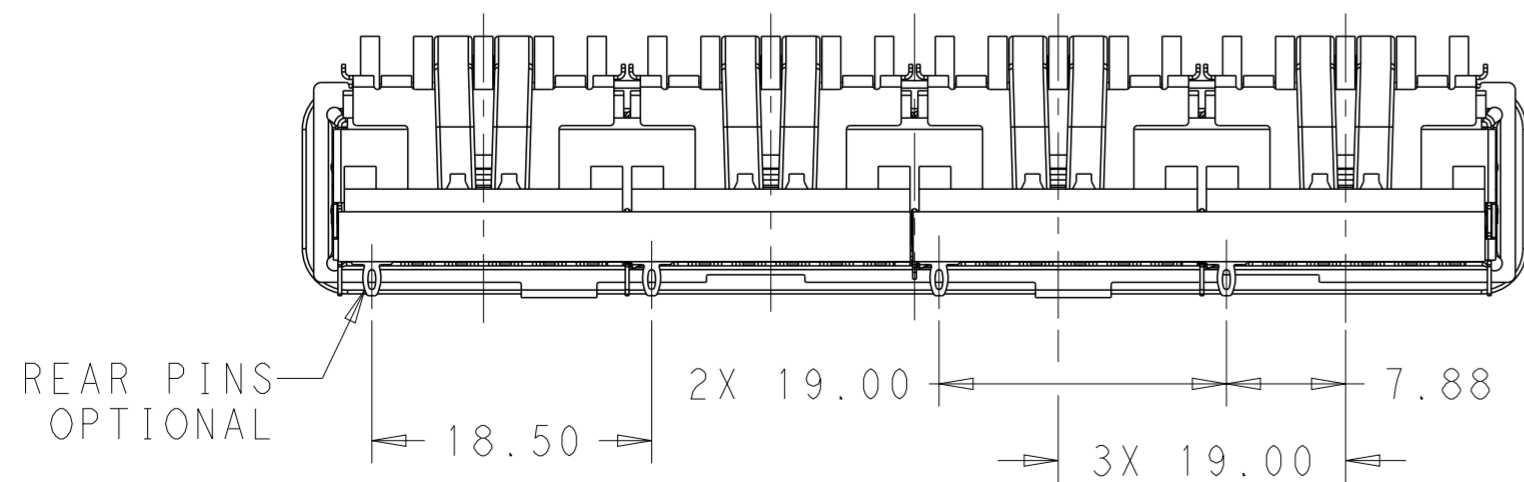

BACK VIEW
SCALE 2:1

THIS DRAWING IS A CONTROLLED DOCUMENT.		DWN 20 JUN 2014 JASON YANG	STE TE Connectivity	
		CHK 01 NOV 2016 SEAN HAN		
DIMENSIONS: mm	TOLERANCES UNLESS OTHERWISE SPECIFIED: 0 PLC ± 1 PLC ±0.25 2 PLC ±0.2 3 PLC ± 4 PLC ±	APVD -	NAME	RECEPTACLE CAGE ASSEMBLY WITH HEAT SINKS AND LIGHT PIPES, THRU BEZEL, 1X4, QSFP28, GASKET
		PRODUCT SPEC	SIZE	CAGE CODE
		108-19428	A2	00779
		APPLICATION SPEC	DRAWING NO	RESTRICTED TO
		114-32023	C-2170785	-
MATERIAL SEE NOTES	FINISH SEE NOTES	WEIGHT	SCALE	SHEET
		-	3:1	1 OF 9
		CUSTOMER DRAWING	REV	A1

THIS DRAWING IS UNPUBLISHED. RELEASED FOR PUBLICATION 20
 © COPYRIGHT 20 BY - ALL RIGHTS RESERVED.

REVISIONS				
P	LTR	DESCRIPTION	DATE	APVD
-		SEE SHEET 1	-	-

HEAT SINK OPTION

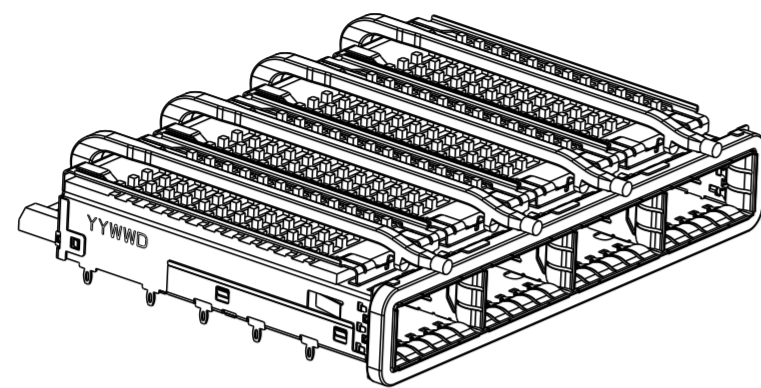

PCI HEAT SINK
SCALE 1:1

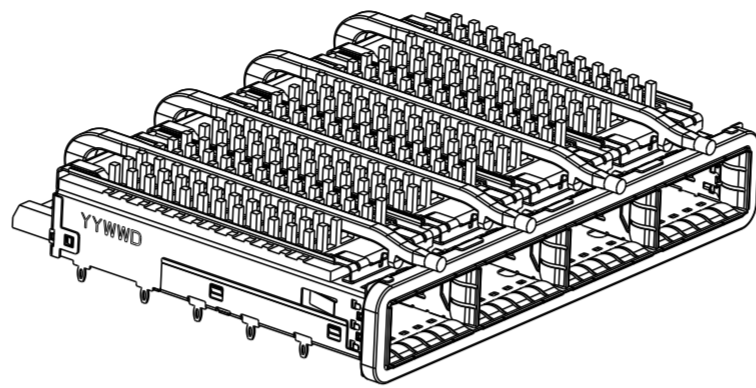

SAN HEAT SINK
SCALE 1:1

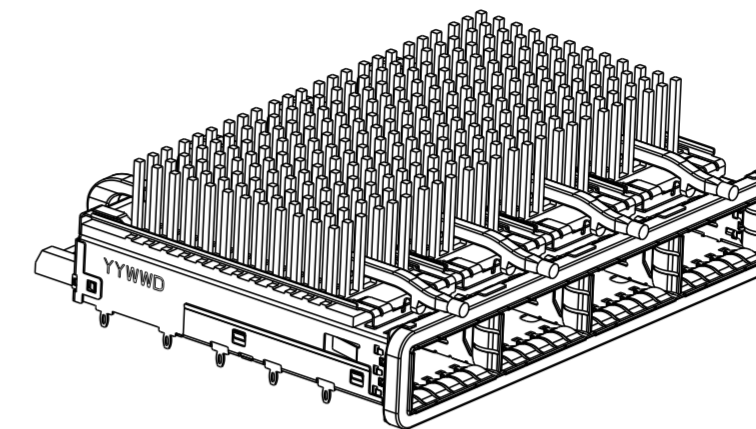

NETWORKING HEAT SINK
SCALE 1:1

LIGHT PIPE OPTION

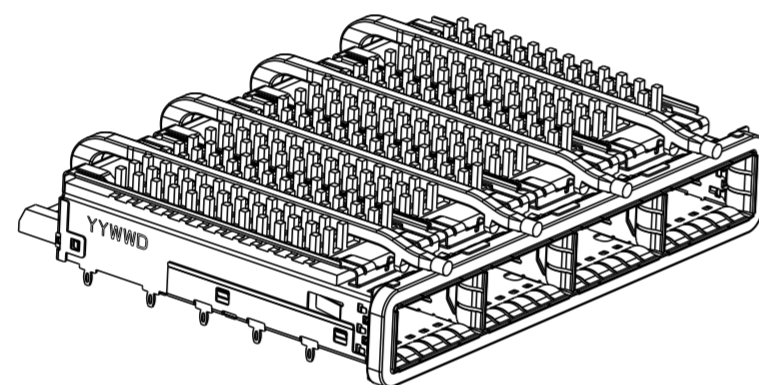

SINGLE LOGHT PIPE
SCALE 1:1

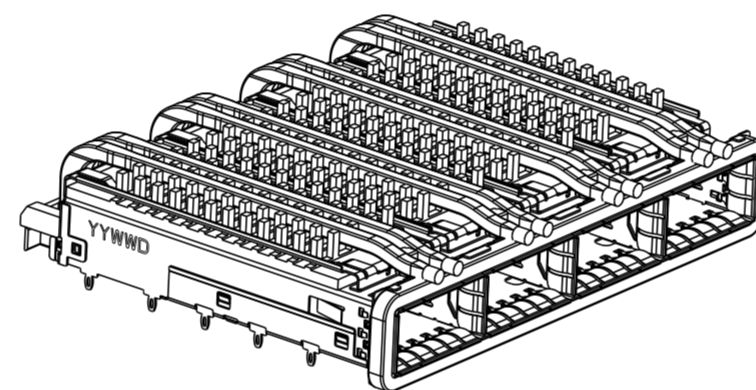

DUAL LIGHT PIPE
SCALE 1:1

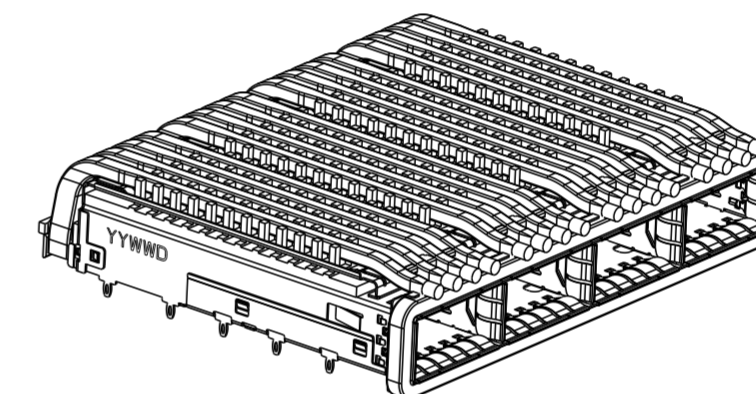

QUAD LIGHT PIPE
SCALE 1:1

OF REAR PIN OPTION

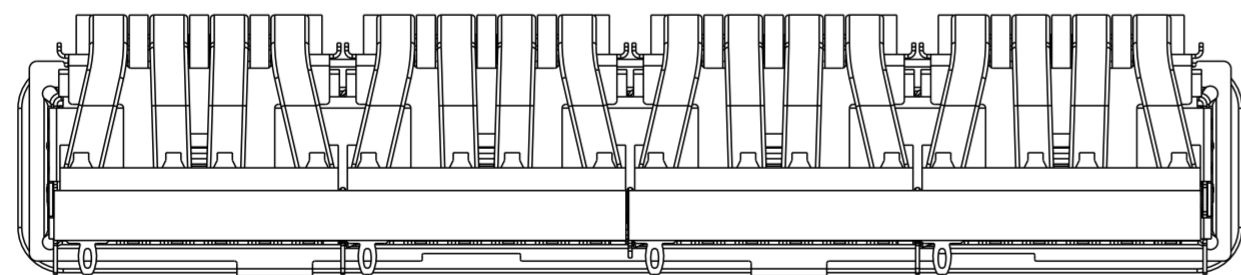

1 REAR PIN
SCALE 2:1

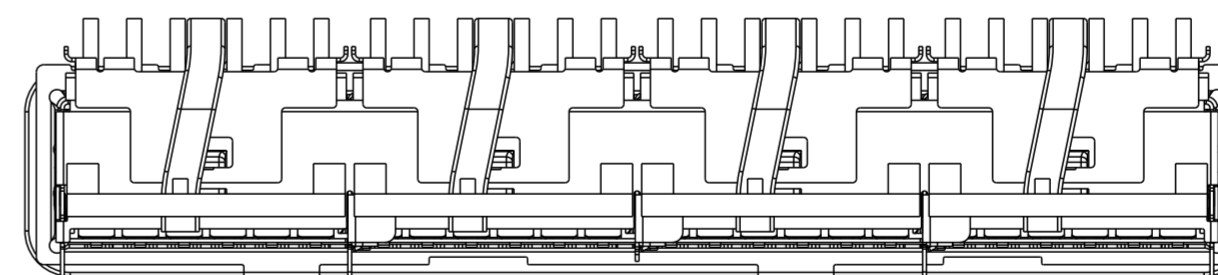

0 REAR PIN
SCALE 2:1

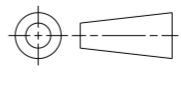
THIS DRAWING IS A CONTROLLED DOCUMENT.		DWN JASON YANG 20 JUN 2014	 TE Connectivity	
		CHK SEAN HAN 01 NOV 2016		
DIMENSIONS: mm	TOLERANCES UNLESS OTHERWISE SPECIFIED:	APVD -	NAME RECEPTACLE CAGE ASSEMBLY WITH HEAT SINKS AND LIGHT PIPES, THRU BEZEL, 1X4, QSFP28, GASKET	RESTRICTED TO
	0 PLC ± 1 PLC ±0.25 2 PLC ±0.2 3 PLC ± 4 PLC ± ANGLES ± FINISH	PRODUCT SPEC 108-19428	SIZE 114-32023	
MATERIAL SEE NOTES	SEE NOTES	APPLICATION SPEC 114-32023	WEIGHT -	SCALE 3:1
		CUSTOMER DRAWING	SIZE A200779	DRAWING NO C-2170785
			SCALE 3:1	SHEET 2 OF 9
				REV A1

THIS DRAWING IS UNPUBLISHED. RELEASED FOR PUBLICATION 20
 © COPYRIGHT 20 BY - ALL RIGHTS RESERVED.

REVISIONS				
P	LTR	DESCRIPTION	DATE	APVD
-		SEE SHEET 1	-	-

0	23.0	NETWORKING	QUAD	4-2170785-6
0	16.0	SAN	QUAD	4-2170785-5
0	13.7	PCI	QUAD	4-2170785-4
1	23.0	NETWORKING	QUAD	4-2170785-3
1	16.0	SAN	QUAD	4-2170785-2
1	13.7	PCI	QUAD	4-2170785-1
0	23.0	NETWORKING	DUAL	2-2170785-6
0	16.0	SAN	DUAL	2-2170785-5
0	13.7	PCI	DUAL	2-2170785-4
1	23.0	NETWORKING	DUAL	2-2170785-3
1	16.0	SAN	DUAL	2-2170785-2
1	13.7	PCI	DUAL	2-2170785-1
0	23.0	NETWORKING	SINGLE	2170785-6
0	16.0	SAN	SINGLE	2170785-5
0	13.7	PCI	SINGLE	2170785-4
1	23.0	NETWORKING	SINGLE	2170785-3
1	16.0	SAN	SINGLE	2170785-2
1	13.7	PCI	SINGLE	2170785-1
# OF REAR PIN	DIM A	APPLICATION	LIGHT PIPE OPTION	PART NUMBER

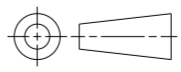
THIS DRAWING IS A CONTROLLED DOCUMENT.		DWN JASON YANG 20 JUN 2014	 TE Connectivity	
		CHK SEAN HAN 01 NOV 2016		
DIMENSIONS: mm	TOLERANCES UNLESS OTHERWISE SPECIFIED:	APVD -	NAME RECEPTACLE CAGE ASSEMBLY WITH HEAT SINKS AND LIGHT PIPES, THRU BEZEL, 1X4, QSFP28, GASKET	
	0 PLC ± 1 PLC ±0.25 2 PLC ±0.2 3 PLC ± 4 PLC ±	PRODUCT SPEC 108-19428	SIZE A2	
	ANGLES ±	APPLICATION SPEC 114-32023	CAGE CODE 00779	DRAWING NO C-2170785
MATERIAL SEE NOTES	FINISH SEE NOTES	WEIGHT -	RESTRICTED TO -	
CUSTOMER DRAWING		SCALE 3:1	SHEET 3 OF 9	REV A1

THIS DRAWING IS UNPUBLISHED. RELEASED FOR PUBLICATION 20
 © COPYRIGHT 20 BY - ALL RIGHTS RESERVED.

REVISIONS					
P	LTR	DESCRIPTION	DATE	DWN	APVD
-	-	SEE SHEET 1	-	-	-

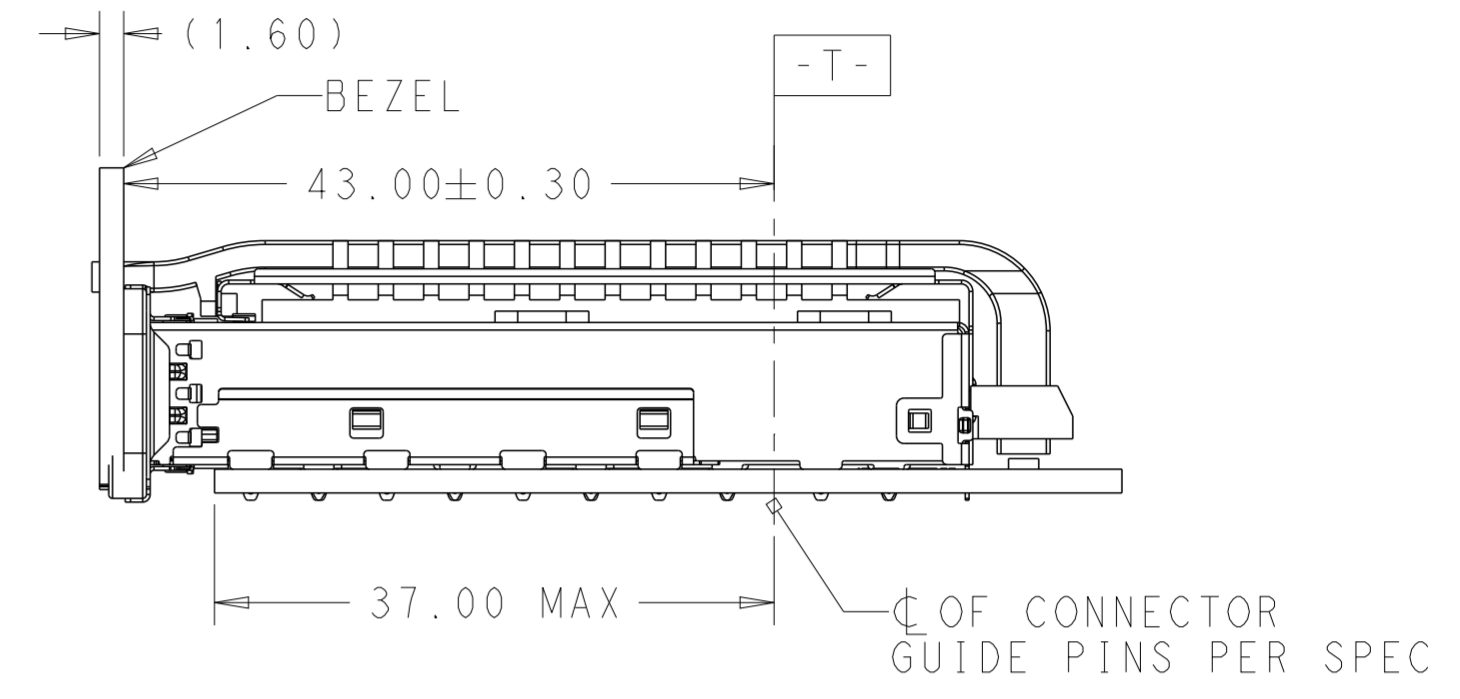
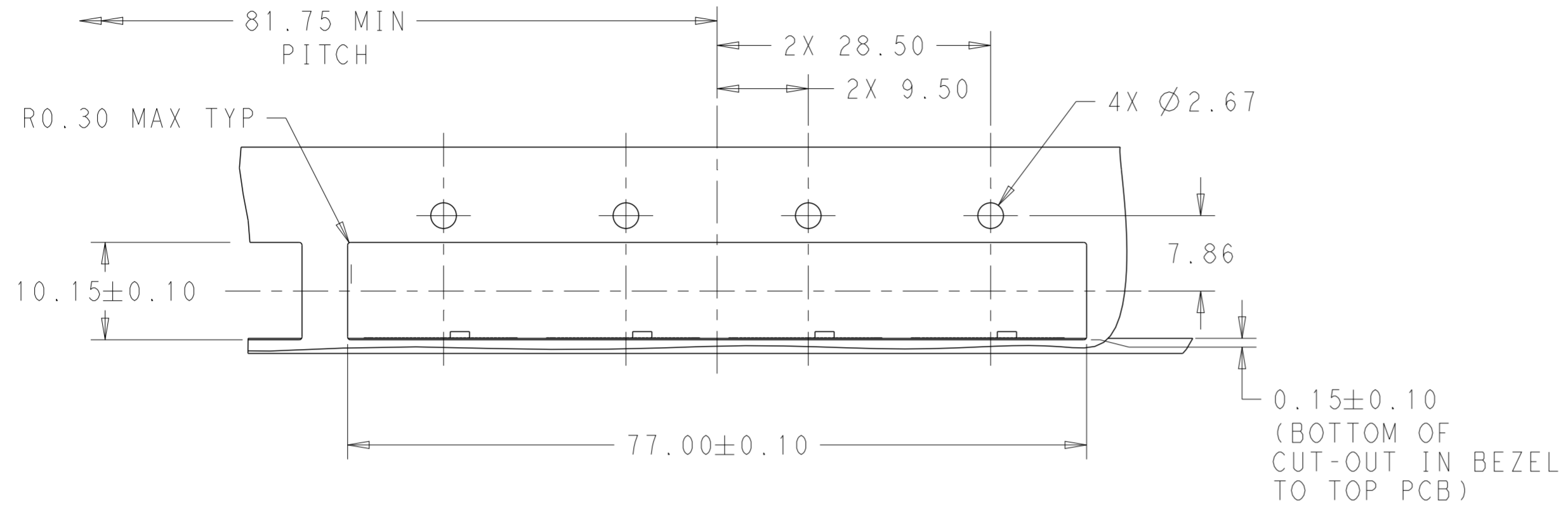

SINGLE SIDE MOUNTING
SCALE 2:1

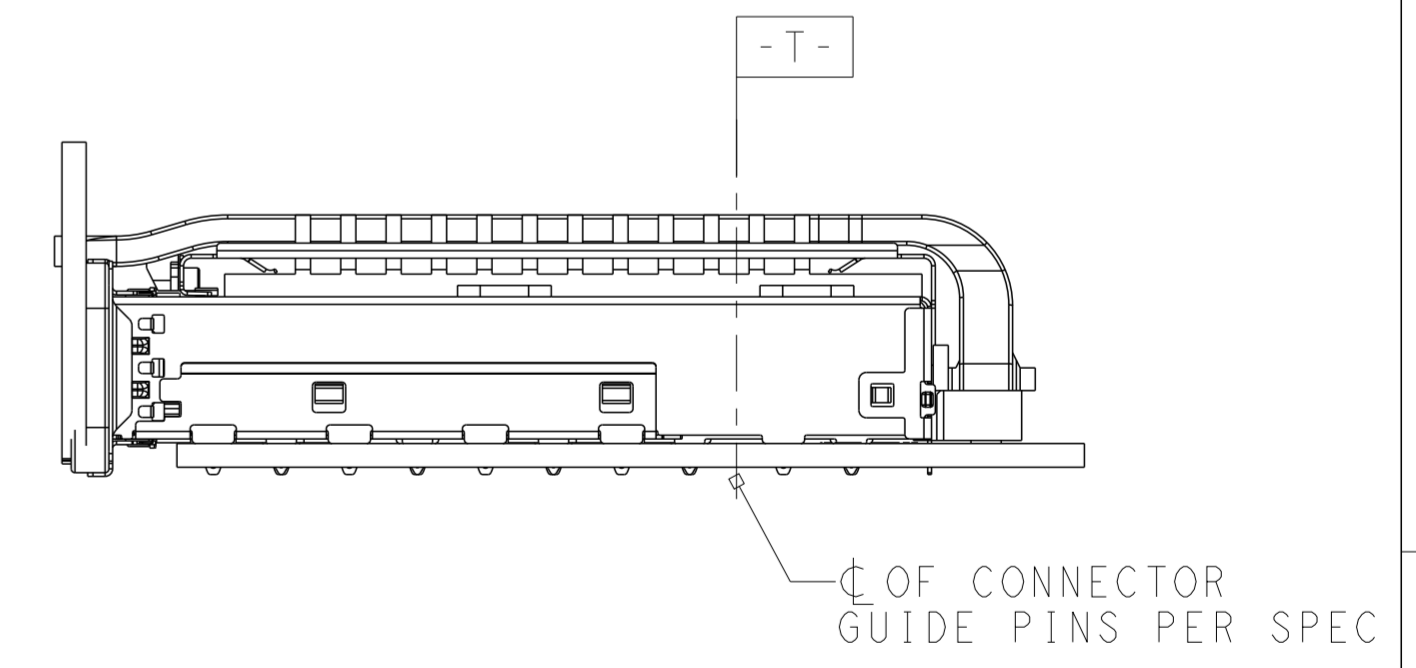
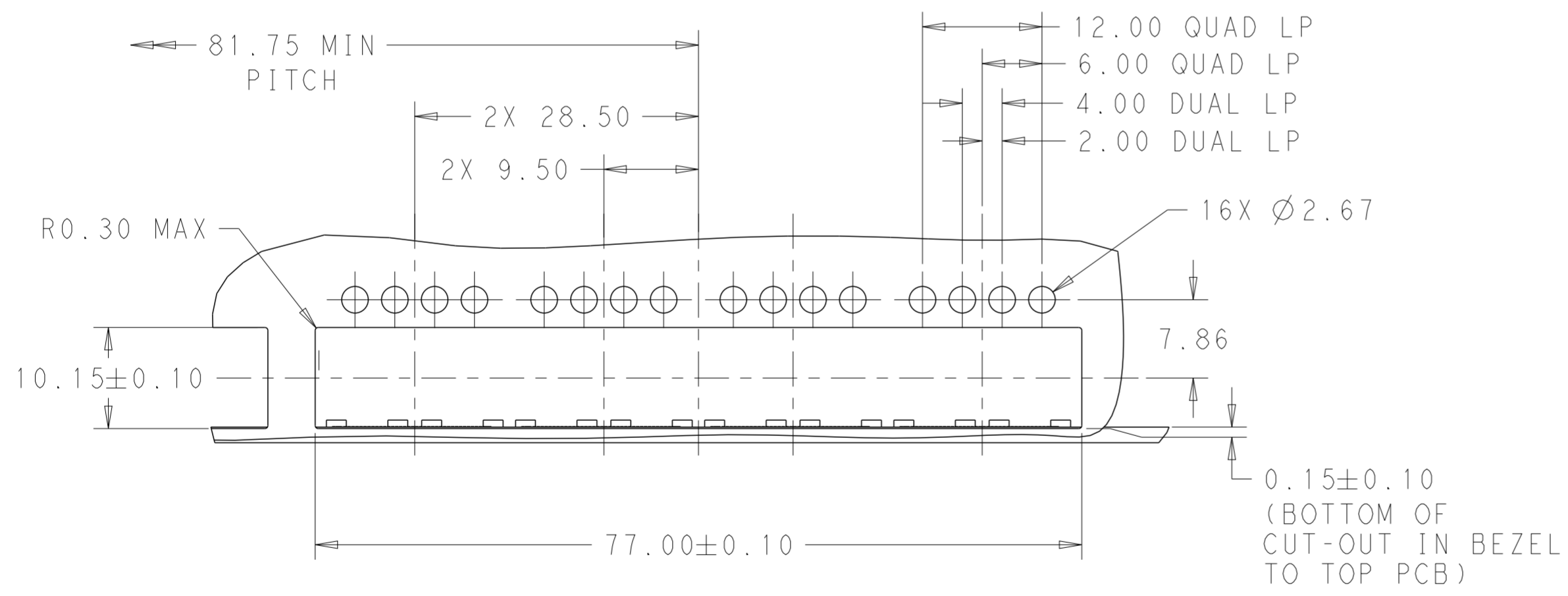

SINGLE SIDE MOUNTING
SCALE 2:1

THIS DRAWING IS A CONTROLLED DOCUMENT.		DWN JASON YANG 20 JUN 2014	TE Connectivity	
		CHK SEAN HAN 01 NOV 2016		
DIMENSIONS: mm	TOLERANCES UNLESS OTHERWISE SPECIFIED:	APVD -	NAME RECEPTACLE CAGE ASSEMBLY WITH HEAT SINKS AND LIGHT PIPES, THRU BEZEL, 1X4, QSFP28, GASKET	RESTRICTED TO
	0 PLC ± 1 PLC ±0.25 2 PLC ±0.2 3 PLC ± 4 PLC ± ANGLES ± FINISH	PRODUCT SPEC 108-19428	SIZE A200779	DRAWING NO C-2170785
MATERIAL SEE NOTES	SEE NOTES	APPLICATION SPEC 114-32023	SCALE 3:1	SHEET 4 OF 9
		WEIGHT -	CUSTOMER DRAWING	REV A1

THIS DRAWING IS UNPUBLISHED. RELEASED FOR PUBLICATION 20
 © COPYRIGHT 20 BY - ALL RIGHTS RESERVED.

REVISIONS				
P	LTR	DESCRIPTION	DATE	APVD
-	-	SEE SHEET 1	-	-

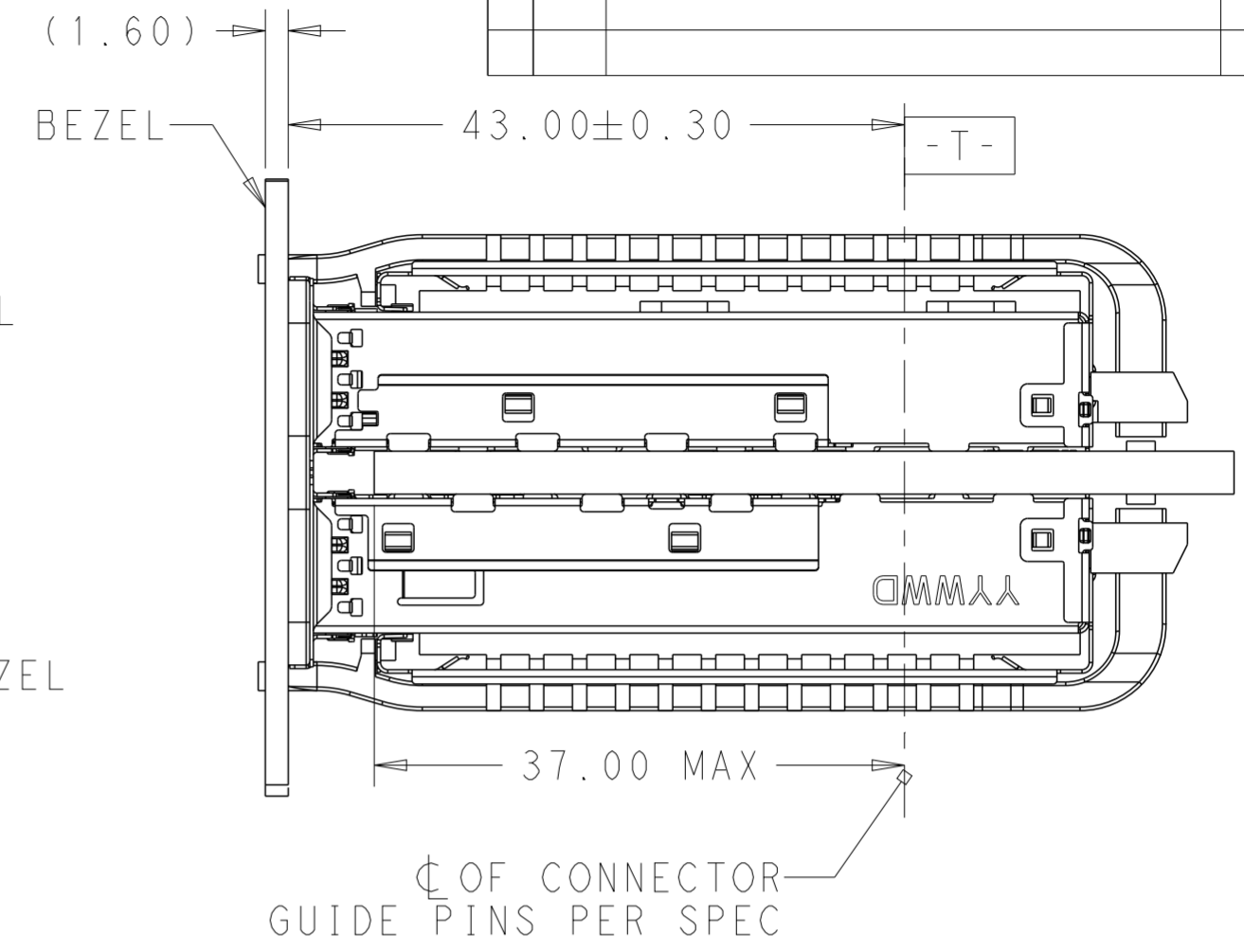
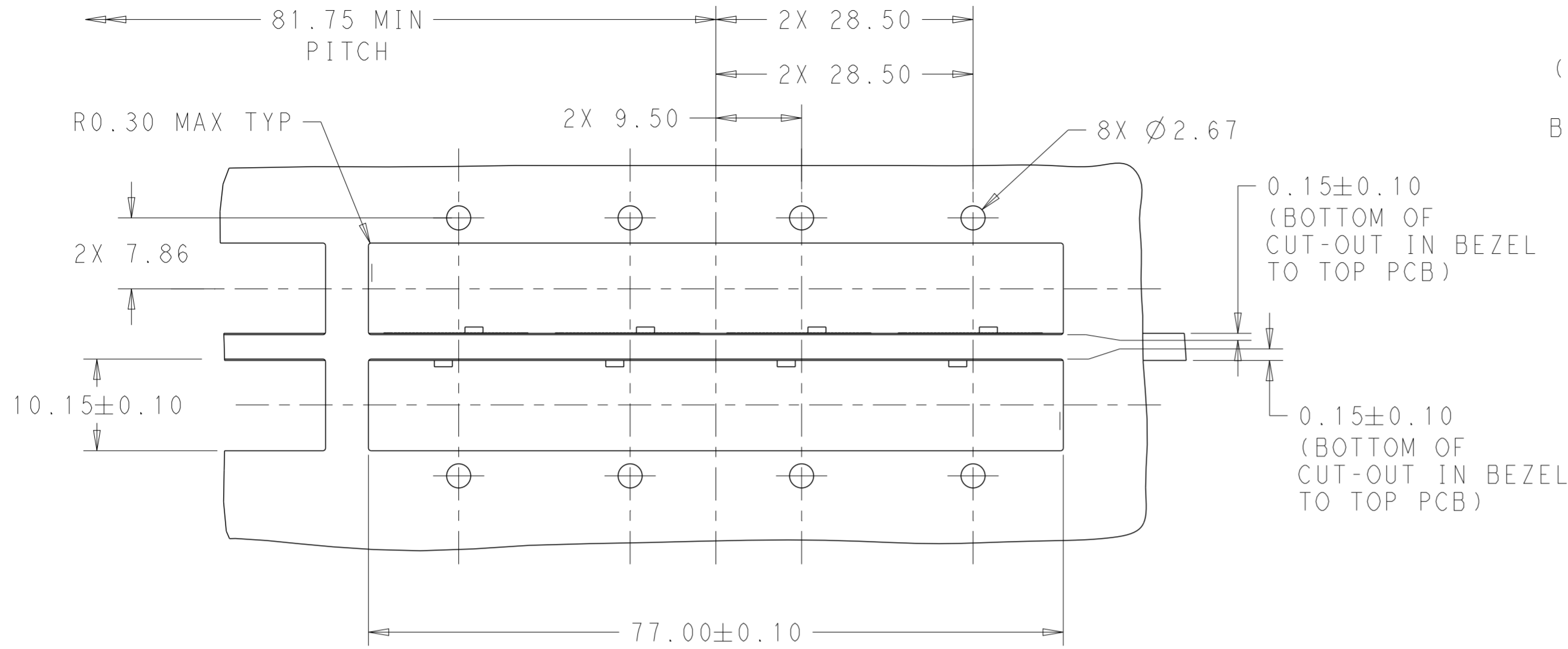

BELLY TO BELLY MOUNTING
SCALE 2:1

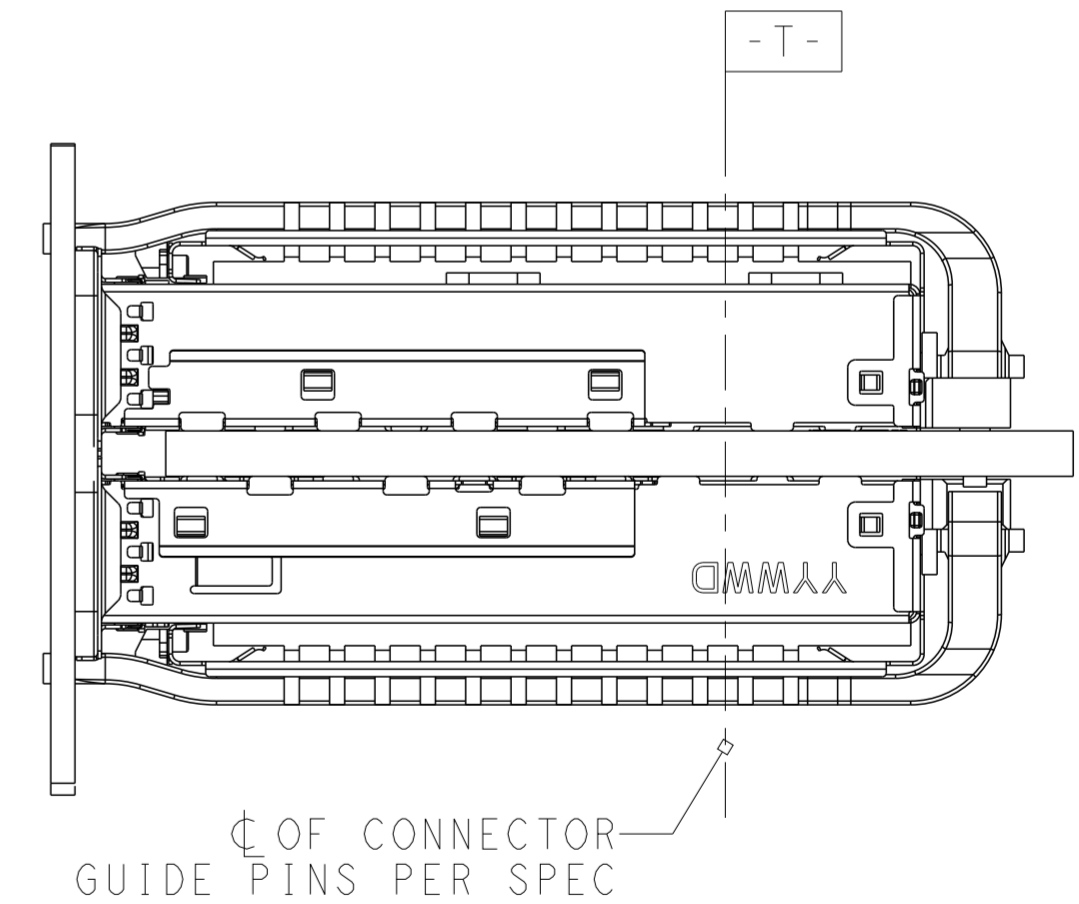
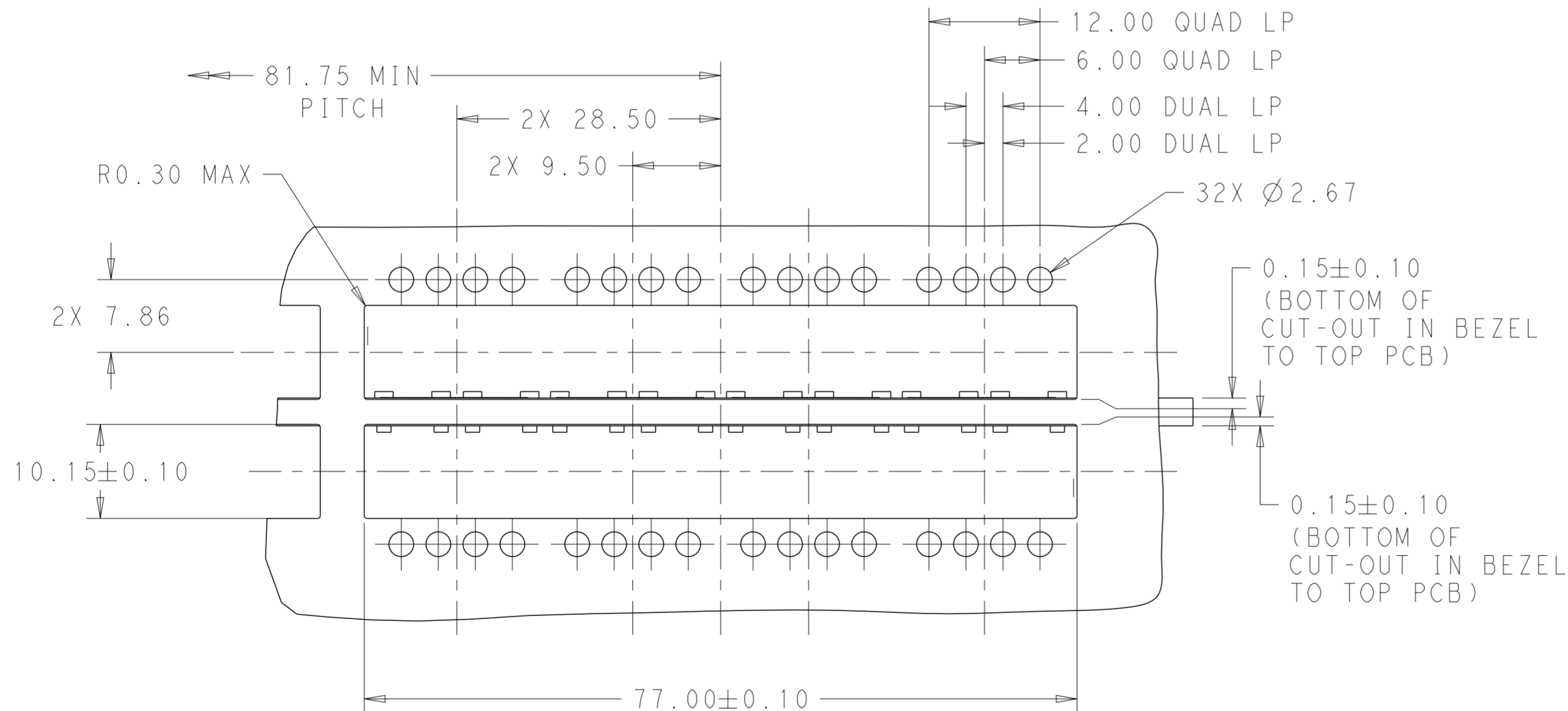

BELLY TO BELLY MOUNTING
SCALE 2:1

THIS DRAWING IS A CONTROLLED DOCUMENT.		DWN JASON YANG 20 JUN 2014	TE Connectivity	
		CHK SEAN HAN 01 NOV 2016		
DIMENSIONS:	TOLERANCES UNLESS OTHERWISE SPECIFIED:	APVD	NAME	
mm	0 PLC ± 1 PLC ±0.25 2 PLC ±0.2 3 PLC ± 4 PLC ± ANGLES ± FINISH ±	PRODUCT SPEC	RECEPTACLE CAGE ASSEMBLY WITH HEAT SINKS AND LIGHT PIPES, THRU BEZEL, 1X4, QSFP28, GASKET	
MATERIAL	SEE NOTES	APPLICATION SPEC	SIZE	RESTRICTED TO
		114-32023	A200779	
		WEIGHT	CAGE CODE	DRAWING NO
			C-2170785	
		CUSTOMER DRAWING	SCALE	SHEET
			3:1	5 OF 9
				REV A1

THIS DRAWING IS UNPUBLISHED. RELEASED FOR PUBLICATION 20
 © COPYRIGHT 20 BY - ALL RIGHTS RESERVED.

REVISIONS				
P	LTR	DESCRIPTION	DATE	APVD
-	-	SEE SHEET 1	-	-

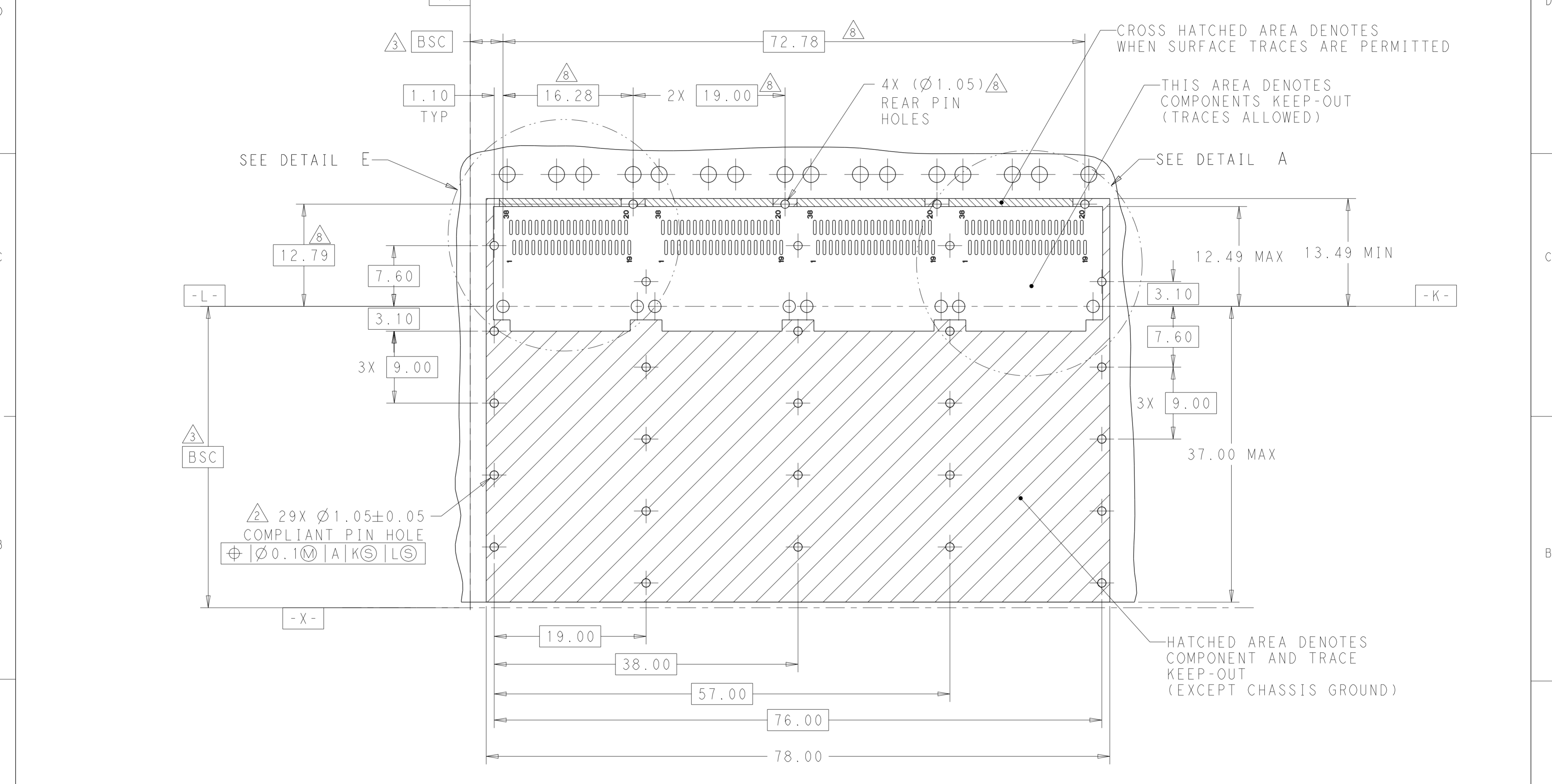

RECOMMENDED PCB LAYOUT
 SINGLE TYPE
 PCB TOLERANCE: ±0.05
 SCALE 3:1

THIS DRAWING IS A CONTROLLED DOCUMENT.		DWN JASON YANG 20 JUN 2014	TE Connectivity	
		CHK SEAN HAN 01 NOV 2016		
DIMENSIONS: mm		TOLERANCES UNLESS OTHERWISE SPECIFIED: 0 PLC ± 1 PLC ±0.25 2 PLC ±0.2 3 PLC ± 4 PLC ± ANGLES ± FINISH SEE NOTES		NAME RECEPTACLE CAGE ASSEMBLY WITH HEAT SINKS AND LIGHT PIPES, THRU BEZEL, 1X4, QSFP28, GASKET
MATERIAL SEE NOTES		PRODUCT SPEC 108-19428 APPLICATION SPEC 114-32023		SIZE A200779
		WEIGHT -		DRAWING NO C-2170785
		CUSTOMER DRAWING		RESTRICTED TO -
		SCALE 3:1		SHEET 6 OF 9 REV A1

THIS DRAWING IS UNPUBLISHED. RELEASED FOR PUBLICATION 20
 © COPYRIGHT 20 BY - ALL RIGHTS RESERVED.

REVISIONS				
P	LTR	DESCRIPTION	DATE	APVD
-	-	SEE SHEET 1	-	-

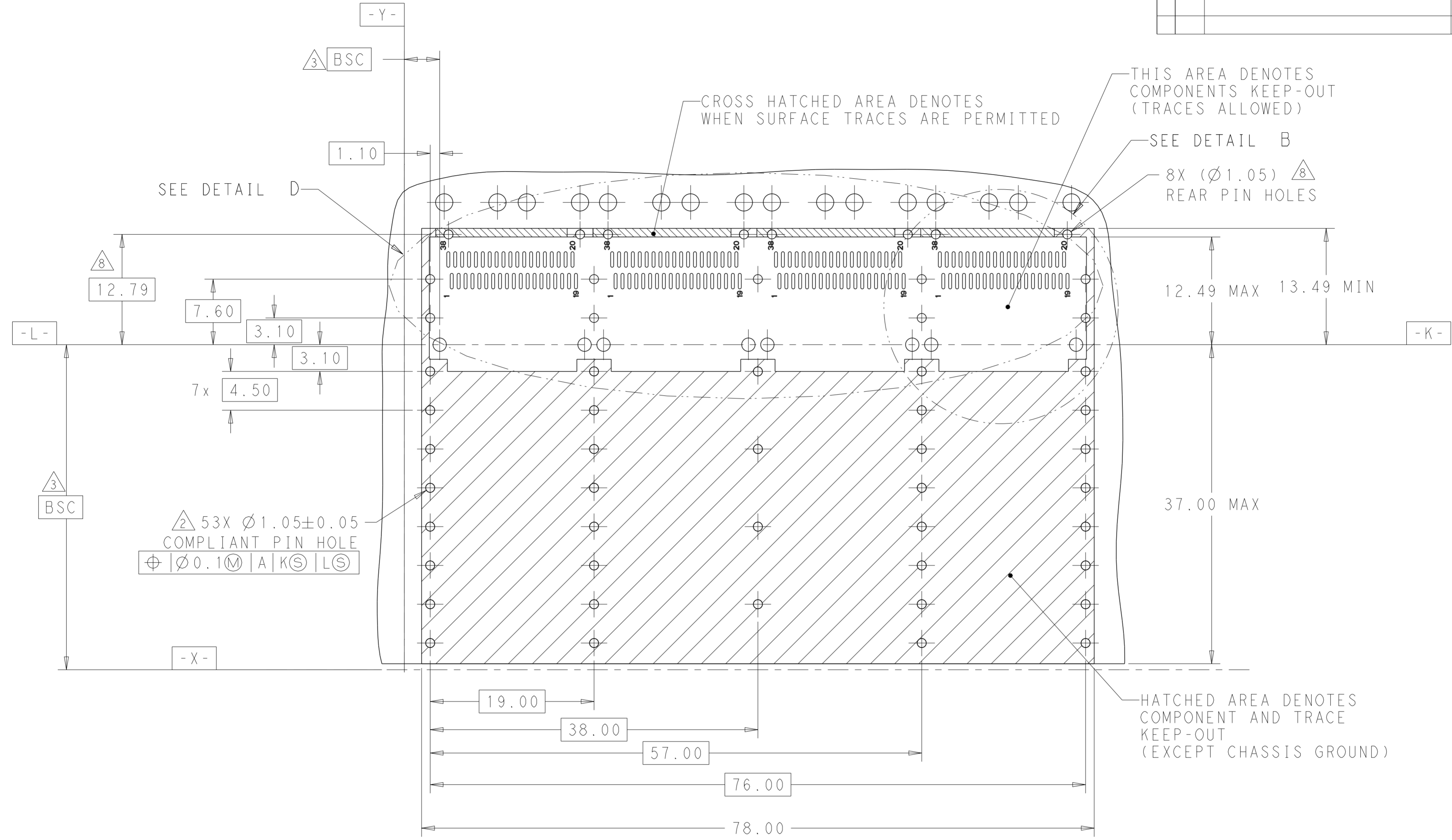

RECOMMENDED PCB LAYOUT
 BELLY TO BELLY TYPE
 PCB TOLERANCE: ±0.05
 SCALE 3:1

THIS DRAWING IS A CONTROLLED DOCUMENT.		DWN JASON YANG 20 JUN 2014	TE Connectivity		
		CHK SEAN HAN 01 NOV 2016			
DIMENSIONS: mm		TOLERANCES UNLESS OTHERWISE SPECIFIED: 0 PLC ± 1 PLC ±0.25 2 PLC ±0.2 3 PLC ± 4 PLC ± ANGLES ± FINISH SEE NOTES		NAME RECEPTACLE CAGE ASSEMBLY WITH HEAT SINKS AND LIGHT PIPES, THRU BEZEL, 1X4, QSFP28, GASKET	
MATERIAL SEE NOTES		PRODUCT SPEC 108-19428 APPLICATION SPEC 114-32023 WEIGHT -		SIZE A200779 CAGE CODE C-2170785 DRAWING NO - RESTRICTED TO -	
		CUSTOMER DRAWING		SCALE 3:1	SHEET 7 OF 9

THIS DRAWING IS UNPUBLISHED. RELEASED FOR PUBLICATION 20
 © COPYRIGHT 20 BY - ALL RIGHTS RESERVED.

REVISIONS				
P	LTR	DESCRIPTION	DATE	APVD
-	-	SEE SHEET 1	-	-

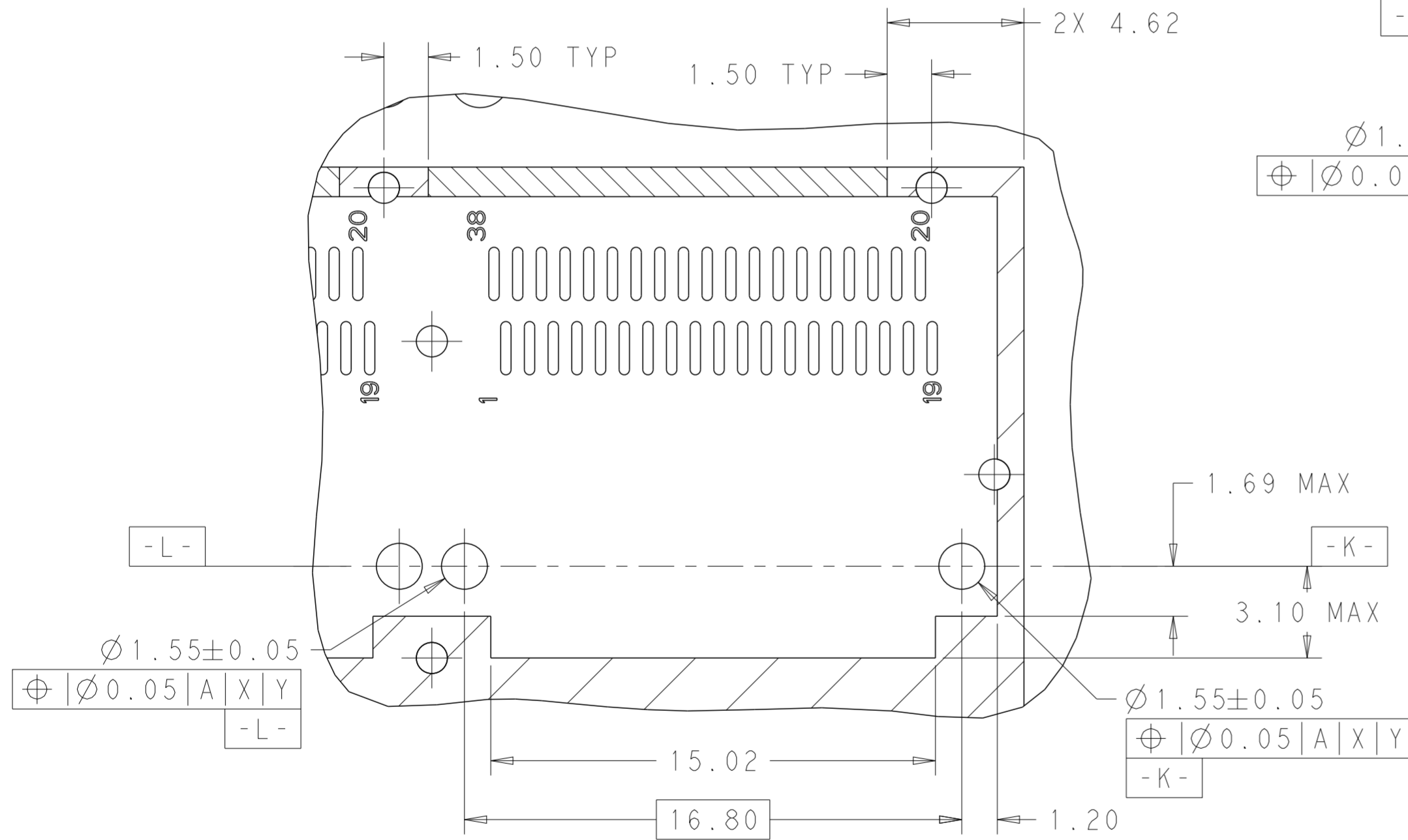

DETAIL A
SCALE 6:1

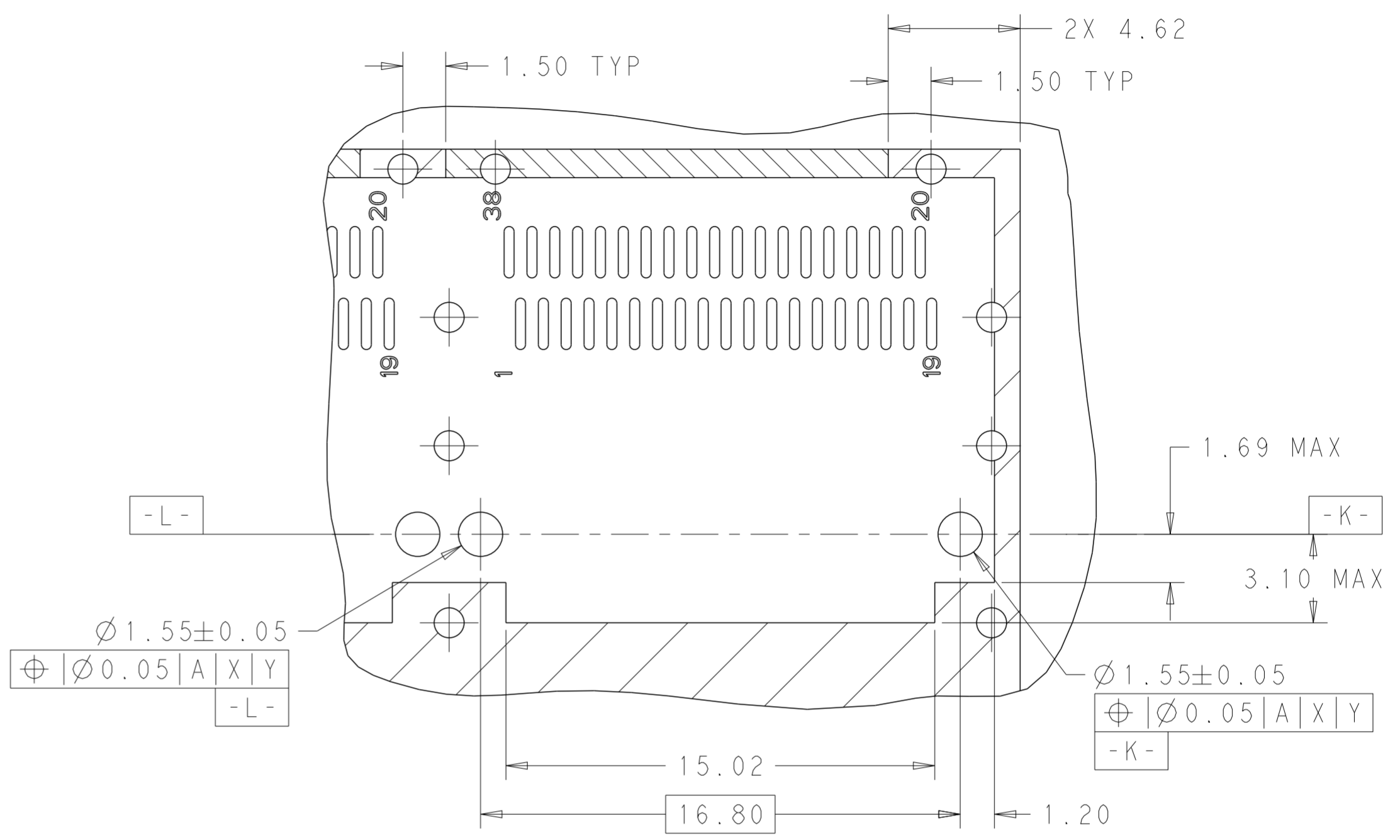

DETAIL B
SCALE 6:1

THIS DRAWING IS A CONTROLLED DOCUMENT.		DWN 20 JUN 2014 JASON YANG	STE TE Connectivity
		CHK 01 NOV 2016 SEAN HAN	
DIMENSIONS: mm	TOLERANCES UNLESS OTHERWISE SPECIFIED:	APVD -	NAME RECEPTACLE CAGE ASSEMBLY WITH HEAT SINKS AND LIGHT PIPES, THRU BEZEL, 1X4, QSFP28, GASKET
	0 PLC ± 1 PLC ±0.25 2 PLC ±0.2 3 PLC ± 4 PLC ± ANGLES ± FINISH	PRODUCT SPEC 108-19428	SIZE A200779
MATERIAL SEE NOTES	SEE NOTES	APPLICATION SPEC 114-32023	CAGE CODE C-2170785
		WEIGHT -	DRAWING NO. -
		CUSTOMER DRAWING	RESTRICTED TO -
		SCALE 3:1	SHEET 8 OF 9
			REV A1

THIS DRAWING IS UNPUBLISHED. RELEASED FOR PUBLICATION 20
 © COPYRIGHT 20 BY - ALL RIGHTS RESERVED.

REVISIONS				
P	LTR	DESCRIPTION	DATE	APVD
-	-	SEE SHEET 1	-	-

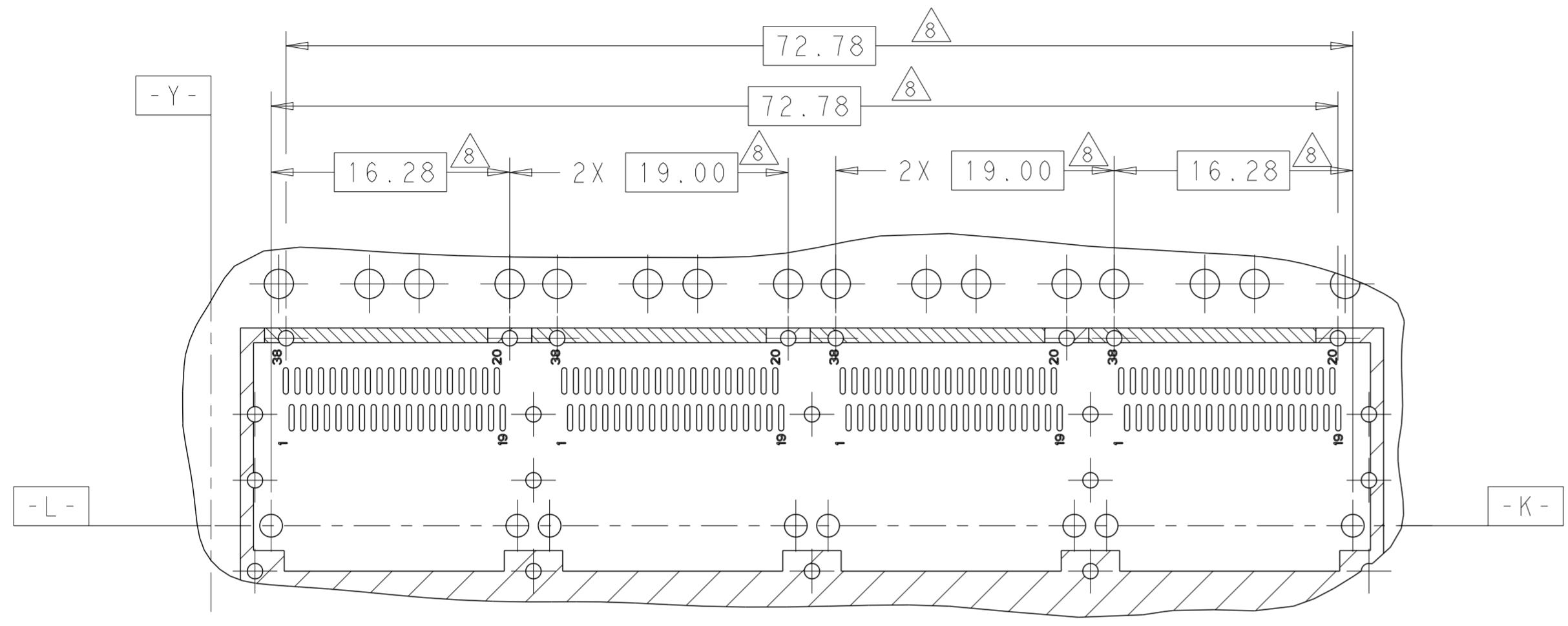

DETAIL D
SCALE 3:1

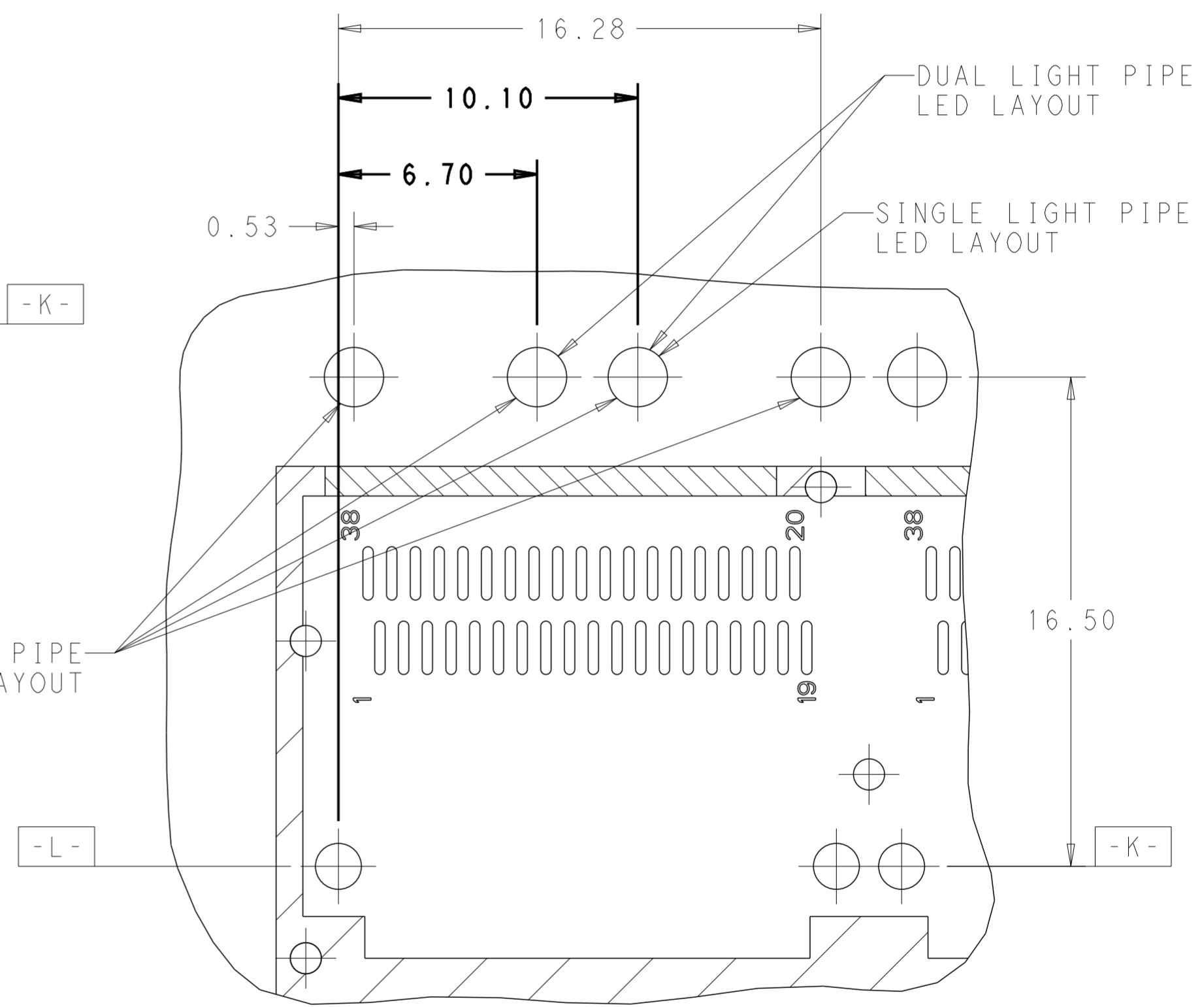

DETAIL E
SCALE 6:1

THIS DRAWING IS A CONTROLLED DOCUMENT.		DWN JASON YANG 20 JUN 2014	TE Connectivity	
		CHK SEAN HAN 01 NOV 2016		
DIMENSIONS:	TOLERANCES UNLESS OTHERWISE SPECIFIED:	APVD	NAME	RECEPTACLE CAGE ASSEMBLY WITH HEAT SINKS AND LIGHT PIPES, THRU BEZEL, 1X4, QSFP28, GASKET
mm	0 PLC ± 1 PLC ±0.25 2 PLC ±0.2 3 PLC ± 4 PLC ±	PRODUCT SPEC	108-19428	
	ANGLES ±	APPLICATION SPEC	114-32023	RESTRICTED TO
MATERIAL	FINISH	WEIGHT	SIZE	CAGE CODE
SEE NOTES	SEE NOTES	-	A2	00779
		CUSTOMER DRAWING	DRAWING NO	C-2170785
		SCALE	3:1	SHEET 9 OF 9
				REV A1