

MATERIALS AND FINISHES

BODY: BRASS
PLATED TRI-M

CONTACT: BRASS
PLATED SILVER

INSULATOR: TEFLON

COUPLING NUT: BRASS
PLATED NICKEL

O-RING: SILICONE RUBBER

NOTE: CONNECTORS SHIPPED
WITH POLYETHYLENE
DUST CAP

PERFORMANCE REQUIREMENTS:

FREQUENCY RANGE: 0-6GHz
IMPEDANCE: 50 OHM
WITHSTAND VOLTAGE(AC): 2500V @0,5mA
VSWR: ≤1.10(0-3GHz)
PIM3(2x20W): ≤-165dBc@1800MHz
WATER-PROOF: IP68 WHEN MATED

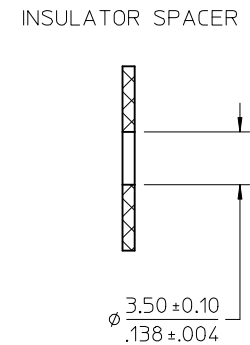
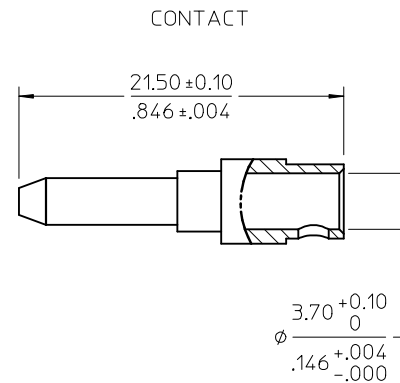
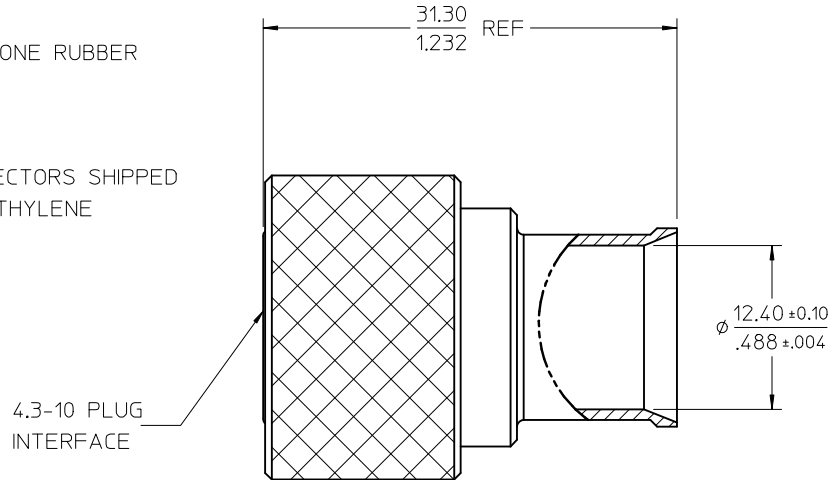
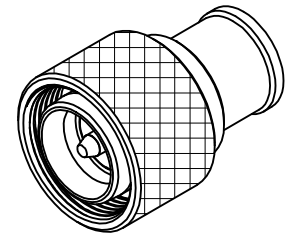

73162-6171	ONE PIECE PER CARTON
73162-6170	BLANK
PART NO.	PACKAGING

IEC61169-54	INTERFACE
SPECIFICATION	DESCRIPTION

CHG: AND PACKAG.
PIM3 -165dBc WAS
-160dBc. PN.73162
WAS 73134

EC NO: URF2016-0691
DRAWN:YHUANG11 2016/04/15
CHKD:
APPR:MYE08 2016/04/20

DESCRIPTION
REV

QUALITY SYMBOLS
▽=0
▽=0
▽=0

GENERAL TOLERANCES (UNLESS SPECIFIED)

	mm	INCH
4 PLACES	± .004	± .0001
3 PLACES	± .003	± .0001
2 PLACES	± .002	± .0001
1 PLACE	± .001	± .0001
0 PLACE	± .000	± .0001

ANGULAR ± 2°

DRAFT WHERE APPLICABLE MUST REMAIN WITHIN DIMENSIONS

DIMENSION STYLE	
MM/IN	
DRAWN BY	DATE
YHUANG11	2015/12/03
CHECKED BY	DATE
MXU11	2015/12/03
APPROVED BY	DATE
MYE08	2016/02/01
MATERIAL NO.	
SEE TABLE	

SCALE	DESIGN UNITS	THIRD ANGLE PROJECTION
	METRIC	
TITLE		
4.3-10 PLUG, 50 OHM FOR 1/2SF CA, SOLDERING 4.3-10-PS,HAND-TIGHT		
molex		
MATERIAL NO.	DOCUMENT NO.	SHEET NO.
	SD-73162-617	1 OF 2
THIS DRAWING CONTAINS INFORMATION THAT IS PROPRIETARY TO MOLEX INCORPORATED AND SHOULD NOT BE USED WITHOUT WRITTEN PERMISSION		

STEP 2

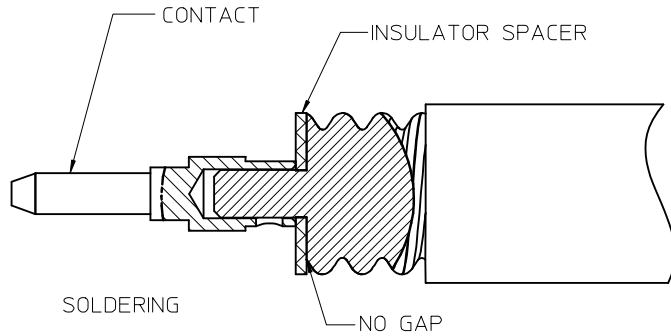

STEP 1

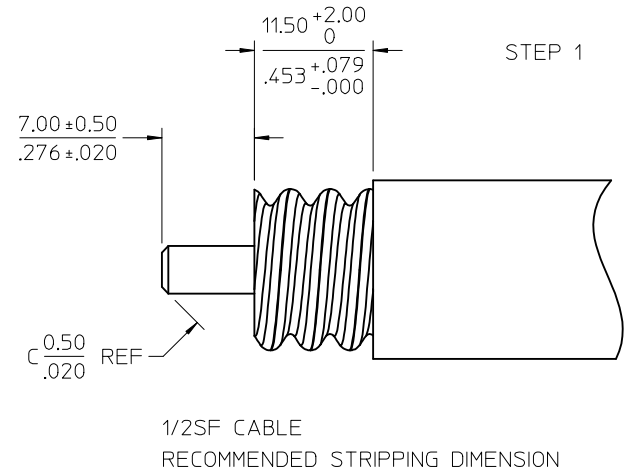

STEP 3

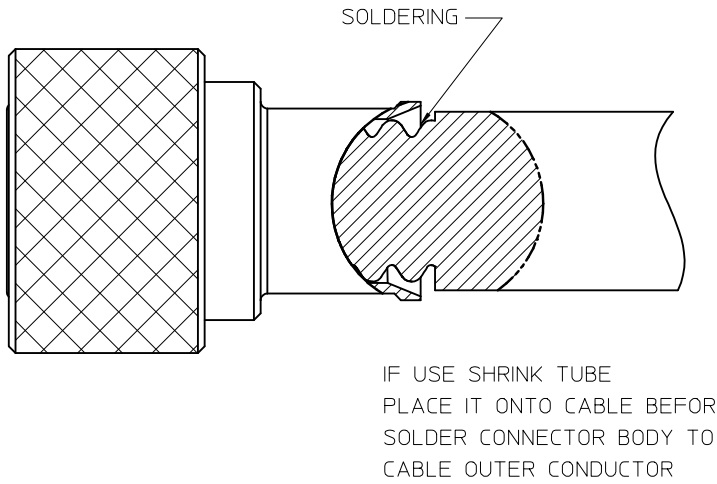

CHG: SEE SHEET 1 EC NO: URF2016-0691 DRWN:YHUANG11 2016/04/15 CHKD: APPR:MYE08 2016/04/20	QUALITY SYMBOLS	GENERAL TOLERANCES (UNLESS SPECIFIED)	DIMENSION STYLE	SCALE	DESIGN UNITS	THIRD ANGLE PROJECTION
	▽=0	mm INCH	MM/IN		METRIC	
	▽=0	4 PLACES ± --- ± ---	DRAWN BY DATE	TITLE		
	▽=0	3 PLACES ± --- ± ---	CHECKED BY DATE			
		2 PLACES ± --- ± ---	MXU11 2015/12/03			
		1 PLACE ± --- ± ---	APPROVED BY DATE			
		0 PLACE ± --- ± ---	MYE08 2016/02/01			
		ANGULAR ± 2°	MATERIAL NO.	DOCUMENT NO.		SHEET NO.
		DRAFT WHERE APPLICABLE MUST REMAIN WITHIN DIMENSIONS	SEE TABLE	SD-73162-617		2 OF 2
			SIZE C	THIS DRAWING CONTAINS INFORMATION THAT IS PROPRIETARY TO MOLEX INCORPORATED AND SHOULD NOT BE USED WITHOUT WRITTEN PERMISSION		