

Rev	AWO #	Description	Date	Appr
-		RELEASED	5/28/15	

APPROVED: _____
 DATE: _____ TITLE: _____

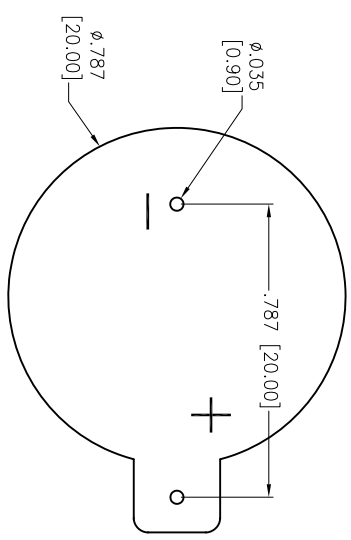
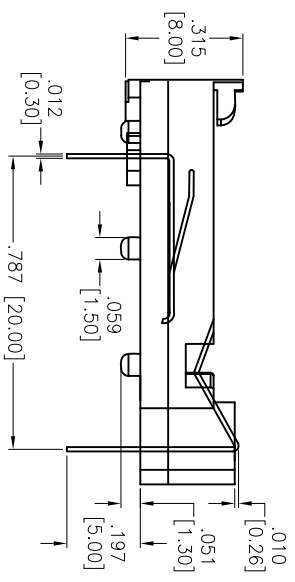
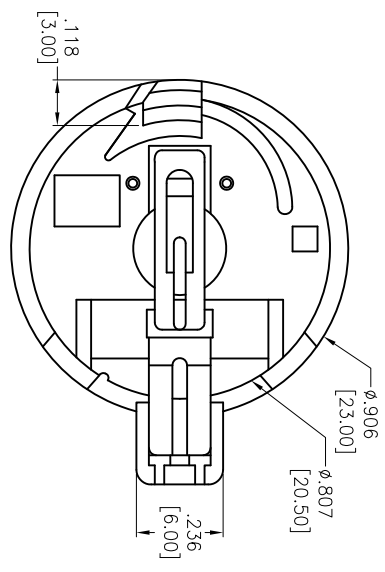

RECOMMENDED PCB LAYOUT

SPECIFICATIONS:

- Material: Insulator: PBT, rated UL 94V-0
- Insulator color: Black
- Contacts: Brass, Tin plated
- Electrical: Contact resistance: 30 mohms max
- Insulation resistance: 1,000 Mohms min
- Dielectric withstanding voltage: 500 VAC one sec level
- Temperature Rating: Operating temperature: -25°C to +85°C
- Environmental: Lead free, RoHS compliant



UNLESS OTHERWISE SPECIFIED ALL DIMENSIONS ARE INCHES [MM] TOLERANCES: EXCEPT AS NOTED			
.X	± .10	ØX	± .10
.XX	± .020	ØXXX	± .015
.XXX	± .015	ØXXXX	± .010

APPROVALS		DATE
DRAWN	HR	5/28/15
CHECKED	OC	5/28/15
APPROVED		

ADAM TECH
 909 Rahway Avenue, Union, NJ 07083
 Phone: 908-687-5000 Fax: 908-687-5710

TITLE	BATTERY HOLDER, PCB THRU HOLE, FOR 2032		
SIZE	PART NO.	REV.	
X	BH-80A-1		
REF:	S00136C	SCALE:	NTS
SHEET	1	OF	1