

CA3151

Single Chip TV Chroma Processor/Demodulator

FEATURES:

- All chroma processing and demodulating circuitry on a single chip in a 24-lead plastic package
- Phase-locked subcarrier regeneration utilizing sample-and-hold techniques
- Supplementary ACC with overload detector to prevent over saturation of the picture tube
- Linear dc controls for chroma gain and tint
- Dynamic "flesh correction"—corrects purple and green flesh colors without affecting primary colors
- Balanced chroma demodulators with low output impedance for direct coupling
- Internal rf filtering
- Requires few external components
- Low system dissipation—nominal 0.5 W

The RCA-CA3151E is a monolithic silicon integrated circuit that performs the complete chroma processor and demodulating functions for color TV. This simple chip contains all the features of the CA3126 chroma processor and the CA3137 chroma demodulator.

The CA3151E is supplied in the 24-lead dual-in-line plastic package.

MAXIMUM RATINGS, Absolute-Maximum Values:

DC SUPPLY VOLTAGE:
Between Terminals 18 and 7 13.2 V

DEVICE DISSIPATION:
Up to $T_A = 55^\circ\text{C}$ 825 mW
Above $T_A = 55^\circ\text{C}$ Derate linearly at
8.7 mW/ $^\circ\text{C}$

AMBIENT TEMPERATURE RANGE:
Operating -40 to $+85^\circ\text{C}$
Storage -65 to $+150^\circ\text{C}$

LEAD TEMPERATURE (During Soldering):
At distance $1/16 \pm 1/32$ inch
(1.59 ± 0.79 mm) from case
for 10 seconds max. $+265^\circ\text{C}$

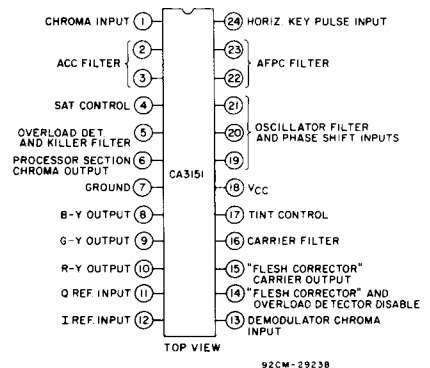

92CM-2923B

TERMINAL DIAGRAM

ELECTRICAL CHARACTERISTICS at $T_A = 25^\circ\text{C}$, $V^+ = 11.6\text{ V}$

| CHARACTERISTIC | TEST CONDITIONS | | | | | | TYPICAL VALUE | UNITS | | |
|--|-----------------|----------------|----------------|-----------|----------|----------------|---------------|---------------|---------------------|-------------------|
| | S ₁ | S ₂ | S ₃ | Chroma In | Burst In | V ₄ | | | V ₁₇ | |
| STATIC (See Fig. 1) | | | | | | | | | | |
| Supply Current, I _T | | | | | | | | 42 | mA | |
| R-Y, G-Y, B-Y, Outputs, V ₈ , V ₉ , V ₁₀ | | | | | | | | 5.3 | V _{dc} | |
| Oscillator Reference Inputs, V ₁₁ , V ₁₂ | | | | | | | | 3.7 | | |
| Chroma Demodulator Input, V ₁₃ | | | | | | | | 2.9 | | |
| Chroma Processor Input, V ₁ | | | | | | | | 2.2 | | |
| DYNAMIC (See Fig. 2) | | | | | | | | | | |
| Minimum Oscillator Pull-In Range*, V ₁₂ | 2 | 1 | 1 | | | | | ±300 | Hz | |
| Oscillator Level, V ₁₂ | 2 | 1 | 1 | | | | 1.5 V | 0.6 | V _{p-p} | |
| 100 Percent ACC, V ₁₃ | 1 | 1 | 1 | | | | | 1 | | |
| Minimum Gain Control, V ₁₃ | 1 | 1 | 1 | | | | 11.6 V | 20 | | mV _{p-p} |
| 50 Percent Gain Control, V ₁₃ | 1 | 1 | 1 | | | | 6 V | 50 | % of 100% ACC Value | |
| 200 Percent ACC, V ₁₃ | 1 | 1 | 1 | | | | | 100 | | |
| 20 Percent ACC, V ₁₃ | 1 | 1 | 1 | | | | | 100 | | |
| Maximum Kill Output, V ₁₃ | 1 | 1 | 1 | | | | | 20 | | mV _{p-p} |
| Minimum Unkill Output, V ₁₃ | 1 | 1 | 1 | | | | | 400 | | |
| Overload Detector (OLD), V ₁₃ | 1 | 1 | 2 | | | | | 1 | V _{p-p} | |
| R-Y Sensitivity, V ₁₀ E _g = 282 mV _{p-p} , 3.53 MHz | 1 | 2 | 1 | | | | | 0.8 | | |
| R-Y Ratio B-Y/R-Y, V ₈ ** | 1 | 2 | 1 | | | | | 120 | | % |
| G-Y Ratio G-Y/R-Y, V ₉ ** | 1 | 2 | 1 | | | | | 33 | | |
| Max. R-Y Output, V ₁₀ E _g = 2 V _{p-p} , 3.53 MHz | 1 | 2 | 1 | | | | | 3 | V _{p-p} | |
| Minimum Tint Control Range, φ ₁₃ | 1 | 1 | 1 | | | | | 0 V to 11.6 V | 80 | Degrees |

* Tune C₂ to 3,579,845 Hz with S₁ in position 2. Put S₁ in position 1, and check for pull in. Repeat for frequency tuned to 3,579,245 Hz. For other tests, frequency tuned to 3,579,545 ± 10 Hz. ** All input levels up to 2 V_{p-p}.

CA3151

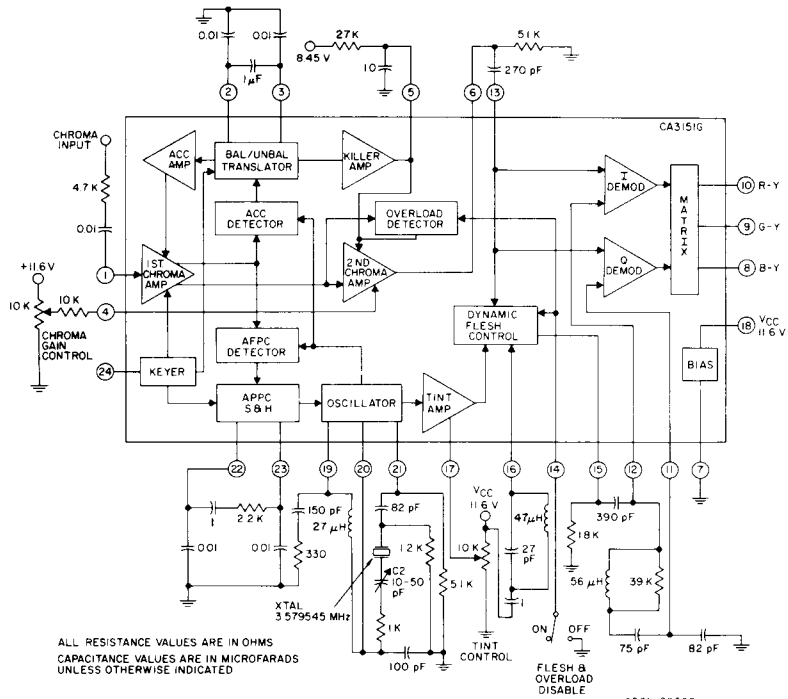

92CL-29239

Fig. 1 - Functional diagram, static test circuit, and typical application circuit.

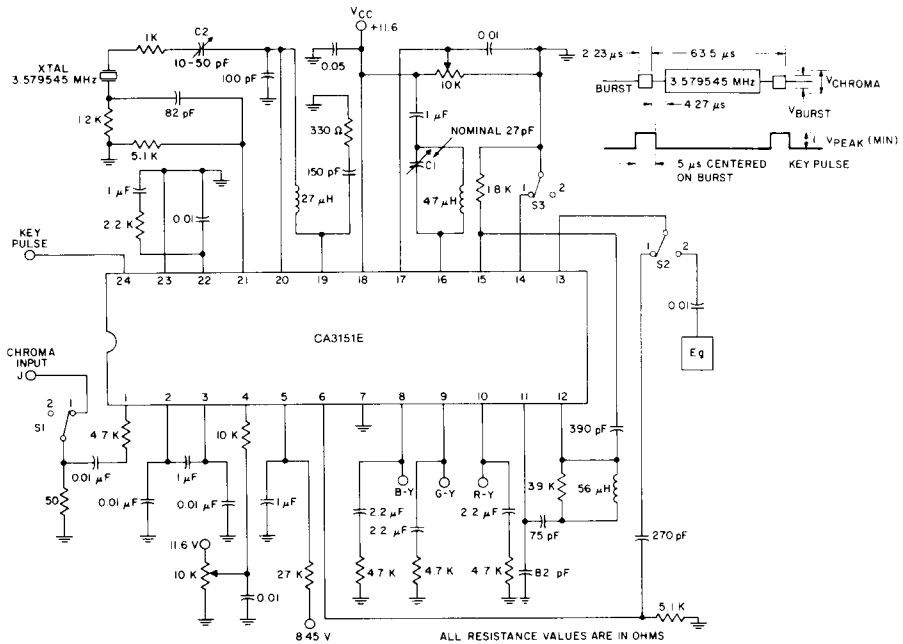

92CL-29236

Fig. 2 - Dynamic test circuit.

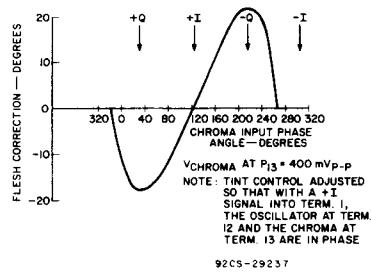

Fig. 3 — "Flesh" correction of oscillator phase angle as a function of chroma input phase angle.