

Introduction

The MicroClock development kit is designed to support the 5X1503/5L1503 devices. It provides a convenient way of verifying, configuring and programming the blank parts for MicroClock devices 5X1503 and 5L1503. The IDT [Timing Commander™](#) GUI supports the devices for configuration and frequency validation on a socket board through a USB programmer board in USB interface. The development kit support programming to MicroClock blank parts either placed into a socket of the board or the blank device soldered on evaluation boards as additional extension boards.

Table 1. 5X1503/5L1503 Family of Products

Product	Description	Package
5X1503	1.8V integrated with an internal 52MHz crystal (standard 5X1503).	10-DFN
5L1503	1.8V using an external crystal (standard 5L1503).	10-DFN
5X1503L	1.8V integrated with an internal 52MHz crystal, low output swing at channel 1.	10-DFN
5L1503L	1.8V using an external crystal, low output swing at channel 1.	10-DFN
5X1503S	1.8V integrated with an internal 52MHz crystal (supports spread spectrum clock).	10-DFN
5L1503S	1.8V using an external crystal (supports spread spectrum clock).	10-DFN

Limit of VCO for Each MicroClock Device

- For standard 5X1503 / standard 5L1503:
 - F_{VCO} : 50MHz – 130MHz
- For 5X1503L / 5L1503L:
 - F_{VCO} : 50MHz – 130MHz
- For 5X1503S / 5L1503S:
 - F_{VCO} : 500MHz – 1100MHz

Socket Board Overview

Use [Figure 1](#) and [Table 2](#) to identify board items and features.

The MicroClock socket board builds in with a MicroClock evaluation part (standard 5X1503 product) with all of the necessary components and connections to test the functionality of the configuration. Users can use the evaluation part for configuration. Once the configuration is final, users can either place blank parts in the socket or connect to a separated evaluation board with a soldered blank part for programming.

To evaluate parts in the socket, un-plug a jumper in JP2 (see the jumper setting in [Figure 10](#)). Test points for Output 1 (label number 9), Output 2 (label number 15), and Output 3 (label number 4) are shown in [Figure 1](#) and [Table 2](#).

Figure 1. Socket Board Overview (5X1503 board shown in below with socket closed)

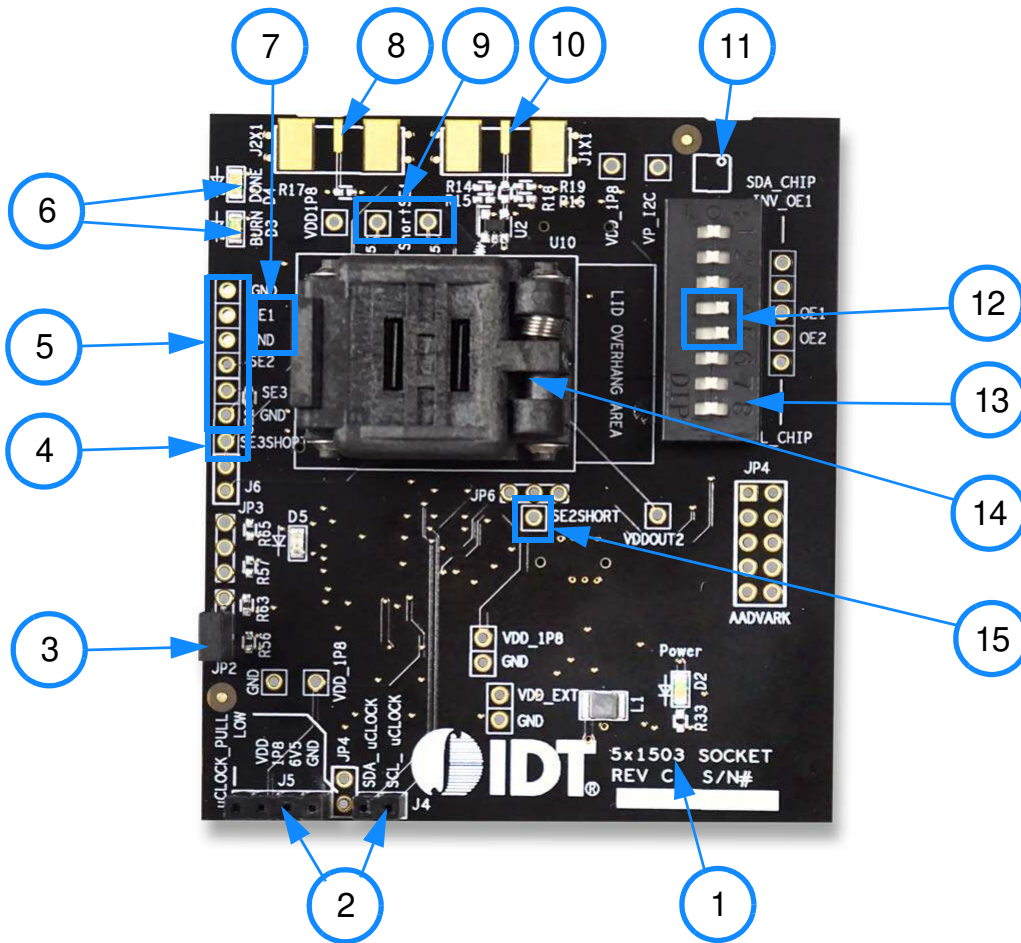

Table 2. Socket Board Descriptions

Label Number	Label Name	Description
1	Device ID (5x1503)	The evaluation board name supports 5X2503 or 5L2503.
2	Connectors	Two set of connectors support configuration programming on evaluation board.
3	Jumper	A switch jumper to control OTP programming function to blank parts either in the socket or evaluation board through the connector.
4	Test Point	Test point for Output 3 from part in socket for 5X1503 and 5L1503.
5	Test Points	Test points for Output 1, Output 2, and Output 3 from evaluation part.
6	LEDs	Two LED lights to indicate the OTP burn process.
7	External crystal	The footprint of external crystal supports 5L1503 / 5L1503L / 5L1503S. Footprint is located on the back of the board.
8	SMA Connector	Connector for supporting either input of external clock for CLKINB/X2 pin or PPS Mode on SE1.
9	Test Points	Test points for Output 1 from part in socket. 5X: Output 1 from 5X1503; 5L: Output 1 from 5L1503.
10	SMA Connector	Connector for supporting either input of external clock for CLKIN/X1 pin or PPS Mode on OE1.
11	Part Indication	Indication for device orientation.
12	Switch Control on OE1 and OE2	Two switch controls to enable/disable outputs in hardware mode from DIP switch. Setting shown is logic high.

Table 2. Socket Board Descriptions (Cont.)

Label Number	Label Name	Description
13	DIP Switch	Used to configure the device in different modes (software mode as default for I2C control; hardware mode as output pin control selection).
14	Socket	10-DFN socket for placing MicroClock blank parts.
15	Test Point	Test point for Output 2 from part in socket for 5X1503 and 5L1503.

Figure 2. Evaluation Board Overview (5X1503 evaluation board shown in below)

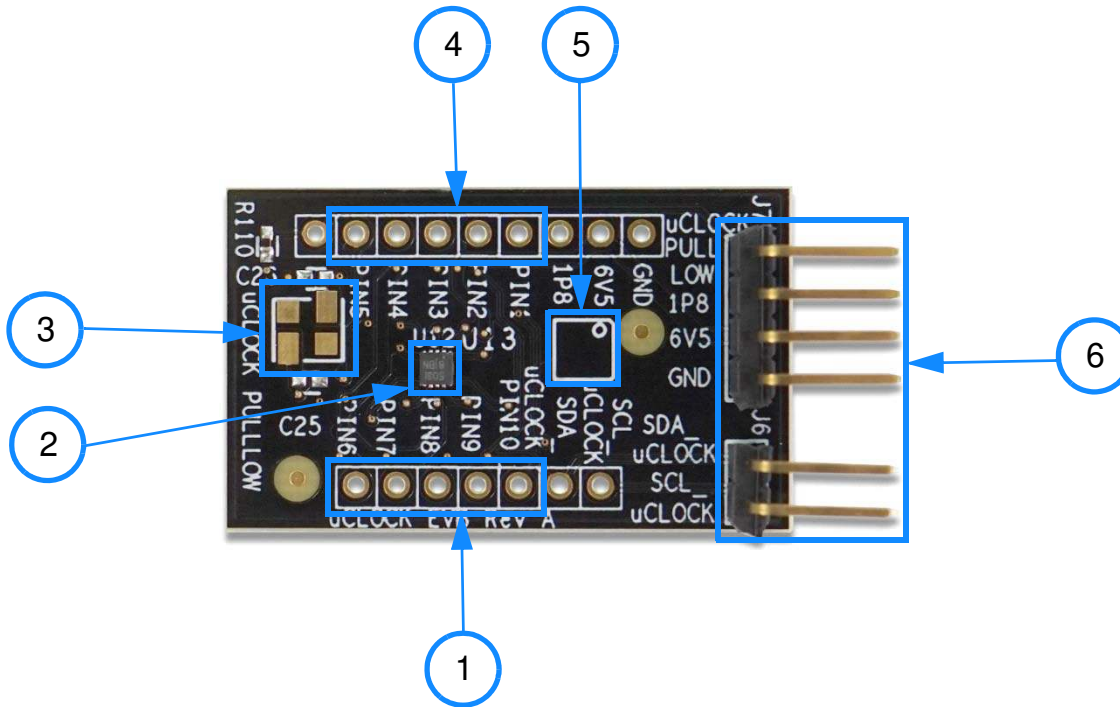
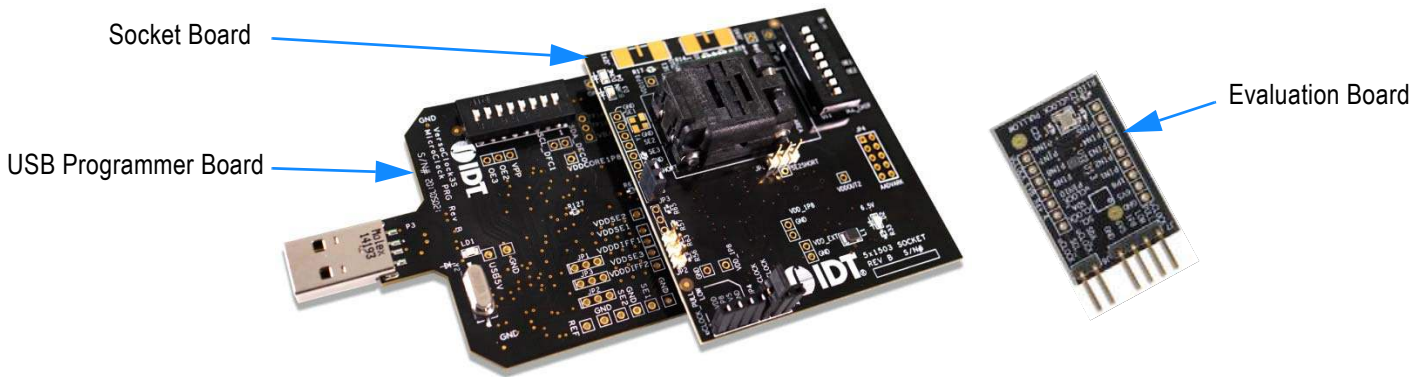

Table 3. Evaluation Board Descriptions

Label Number	Label Name	Function
1	Test Points	Test points for PIN6, PIN7, PIN8, PIN9, and PIN10 (in order of appearance from left to right).
2	5X1503	MicroClock device soldered on evaluation board.
3	External Crystal	The footprint of external crystal supports for 5L1503 / 5L1503L / 5L1503S.
4	Test Points	Test points for PIN5, PIN4, PIN3, PIN2, and PIN1 (in order of appearance from left to right).
5	Part Indication	Indication for device orientation.
6	Headers for Connector	Separated for 2 and 4 headers as connection between socket and evaluation boards.

Figure 3. Development Kit Boards



The socket board for all MicroClock products, combined with a USB programmer board, is used for the purpose of validation and measurement on all outputs. The development kit offers two ways to program a configuration to either a blank part in the socket or a blank part soldered on an evaluation board for validation. Blank parts can drop into the socket of the socket board for programming on different MicroClock family devices. The evaluation board is another option for configuration programming so it can be brought over to any system board for clocking support. Note that blank parts can only be burnt once through the socket board. The socket board is bundled with a USB programmer board. The following description and images are restricted to the socket board.

On the footprint of the socket board, a pin orientation identifies the position of Pin 1 as shown in Figure 4. Align the dot of the blank part in the socket as pointed. After placing the blank part, secure the socket cover.

Figure 4. Socket Board (pin position)

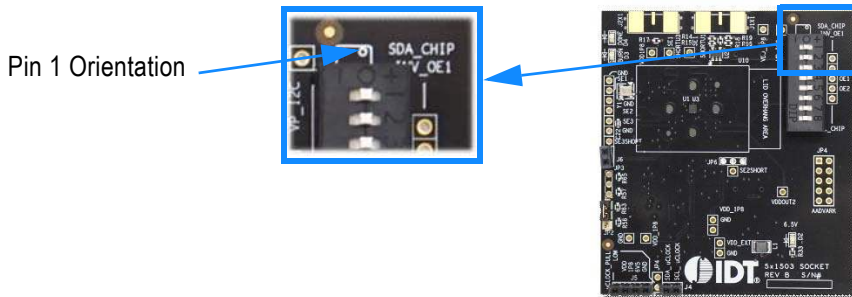
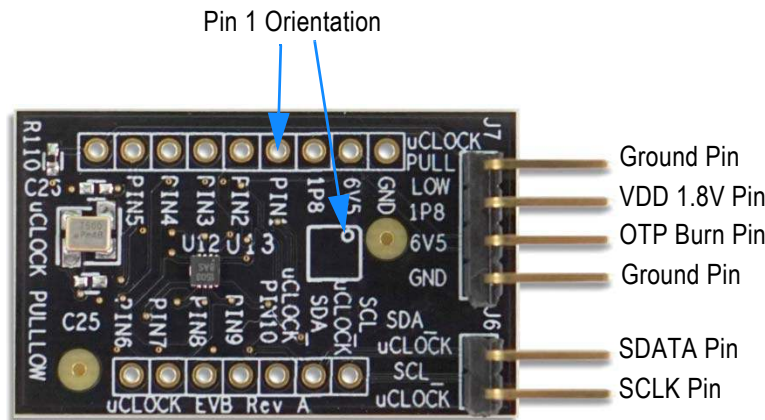





Figure 5. Evaluation Board (pin position)



Programming Steps

Use programming steps 2 – 7 as described in the [Table 4](#) to program a configuration into the blank part in the specified socket board.

Table 4. Programming Steps

Step Number	Step description	Comments
0	A configuration has been validated and completed on the development kit.	Configurations should have programmed to the 12-pin evaluation part for validation on the socket board through the USB programmer board using Timing Commander.
1	All intended outputs should be available for measurement on the USB development kit.	Upon validation of the outputs, “Disconnect” the USB board and proceed for OTP burn as explained in the following sections.
2	Plug the specified socket board onto the USB programmer board (shown in Figure 3).	USB programmer board with the socket board provides a communication channel between the GUI and a blank part in the socket board.
3	Start Timing Commander software (this step can be skipped if a configuration is ready in the personality).	Launch the Timing Commander GUI software. Load the personality file.
4	New settings file (this step can be skipped if a configuration is ready in the personality).	Using the Timing Commander GUI, start a new settings file or open a pre-optimized file.
5	Connect to the development kit.	Click on the chip symbol on the top right corner of the GUI window. 
6	—	Once connected, new options will be available on a green background indicating that the USB programmer board has successfully connected with the socket board. 
7	Click the “Write all” icon.	The configuration will be programmed into the blank part in the socket. 

Use the following steps to proceed with the OTP burn.

- After the chip is connected to the Timing Commander, the main window of configuration is shown (see Figure 6). Click the OTP icon on the left side of personality window.

Figure 6. Personality Main Window

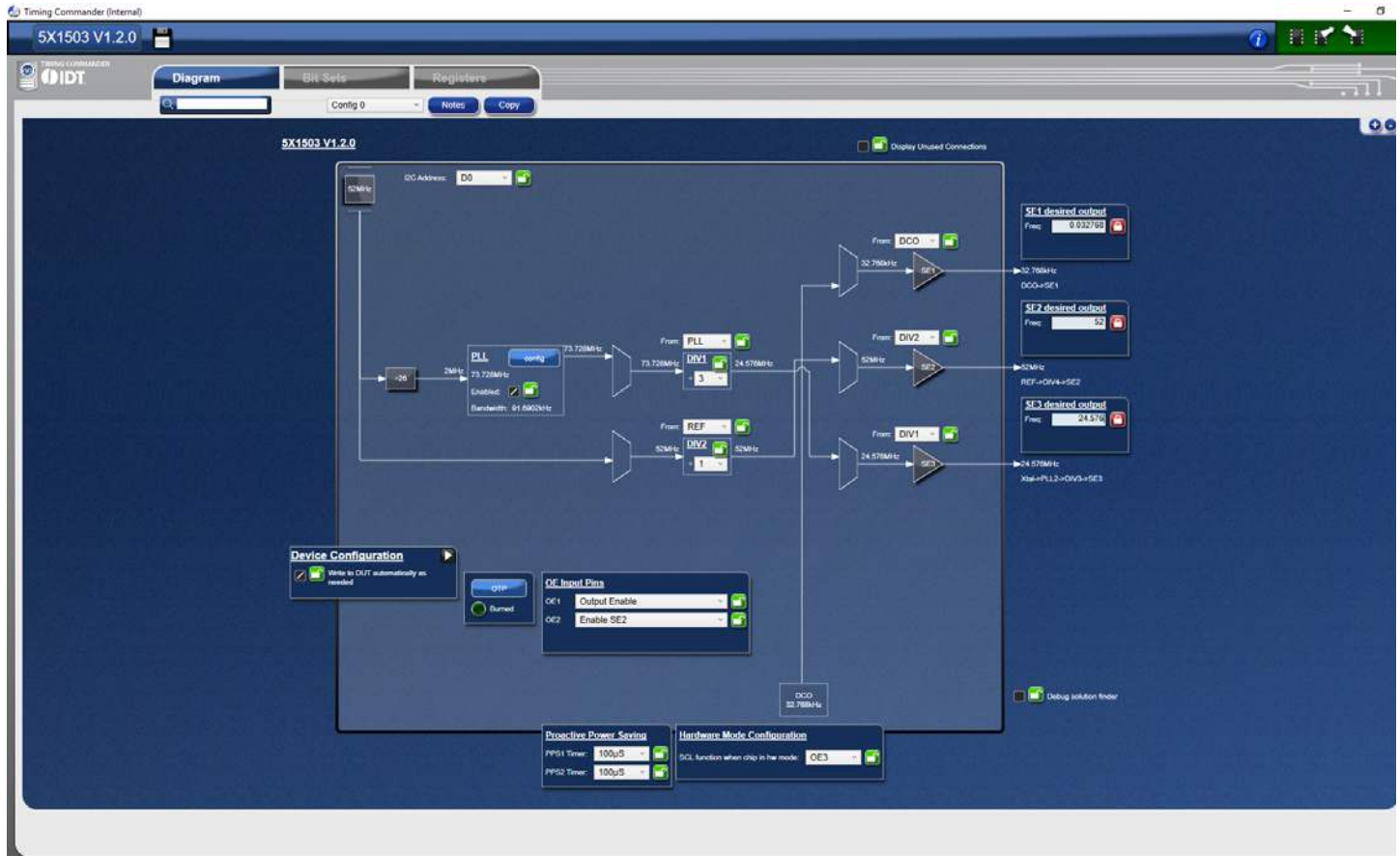

- After clicking the icon, a new dialogue window will open (see Figure 7). Set the burning protection for the desired Config/DFC to configure the OTP Burn (default is “Burn”). Click “Burn” to proceed with the OTP burn process. Please note that this process cannot be reverted back.

Figure 7. Burn Dialog Window



10. Once “Burn” is clicked, a dialog of confirmation will appear verifying if the development kit has connected with user PC for OTP programming. Click “Yes” to proceed with the OTP burn.

Figure 8. Connection Confirmation Window

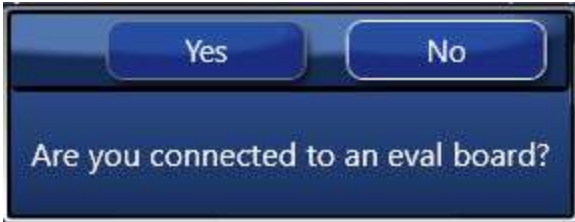

11. If the OTP burn process is successful, a dialog window with “Success” will appear indicating that the process is completed and the part has been burnt based on the configuration.

Figure 9. Success Dialog Window

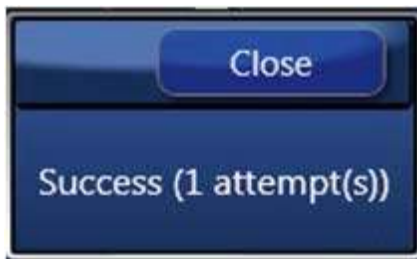

JP2 on MicroClock socket board provides a select function for configuration programming to either the evaluation part or blank parts in socket or on an evaluation board. To program OTP on a blank part in the socket or an evaluation board, ensure to un-plug the jumper on JP2 (default jumper sets to be plugged). See [Figure 10](#).

Figure 10. Jumper Setup

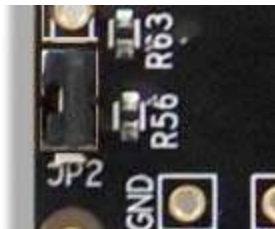
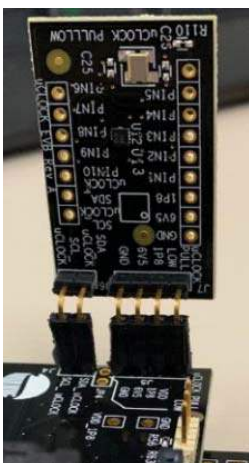

Figure 11. Connection between Socket Board and Evaluation Board



Termination Options–Default

Table 5. Termination for Single-ended Output (option 1)

Signal Type	Series Resistor, R4
LVC MOS for VDDO set at 1.8V	22Ω
LVC MOS for VDDO set at 1V, 1.1V and 1.2V	20Ω
LVC MOS for 32.768kHz output	0 Ω

Table 6. Termination for Single-ended Output (option 2)

Signal Type	Series Resistor, R2
LVC MOS for VDDO set at 1.8V	22Ω
LVC MOS for VDDO set at 1V, 1.1V and 1.2V	20Ω

Table 7. Termination for Single-ended Output (option 3)

Signal Type	Series Resistor, R1
LVC MOS	22Ω
LVC MOS for VDDO set at 1V, 1.1V and 1.2V	20Ω

Schematics

Development kit socket board and evaluation board schematics are shown on the following pages.

Figure 12. Development Kit Socket Board Schematic

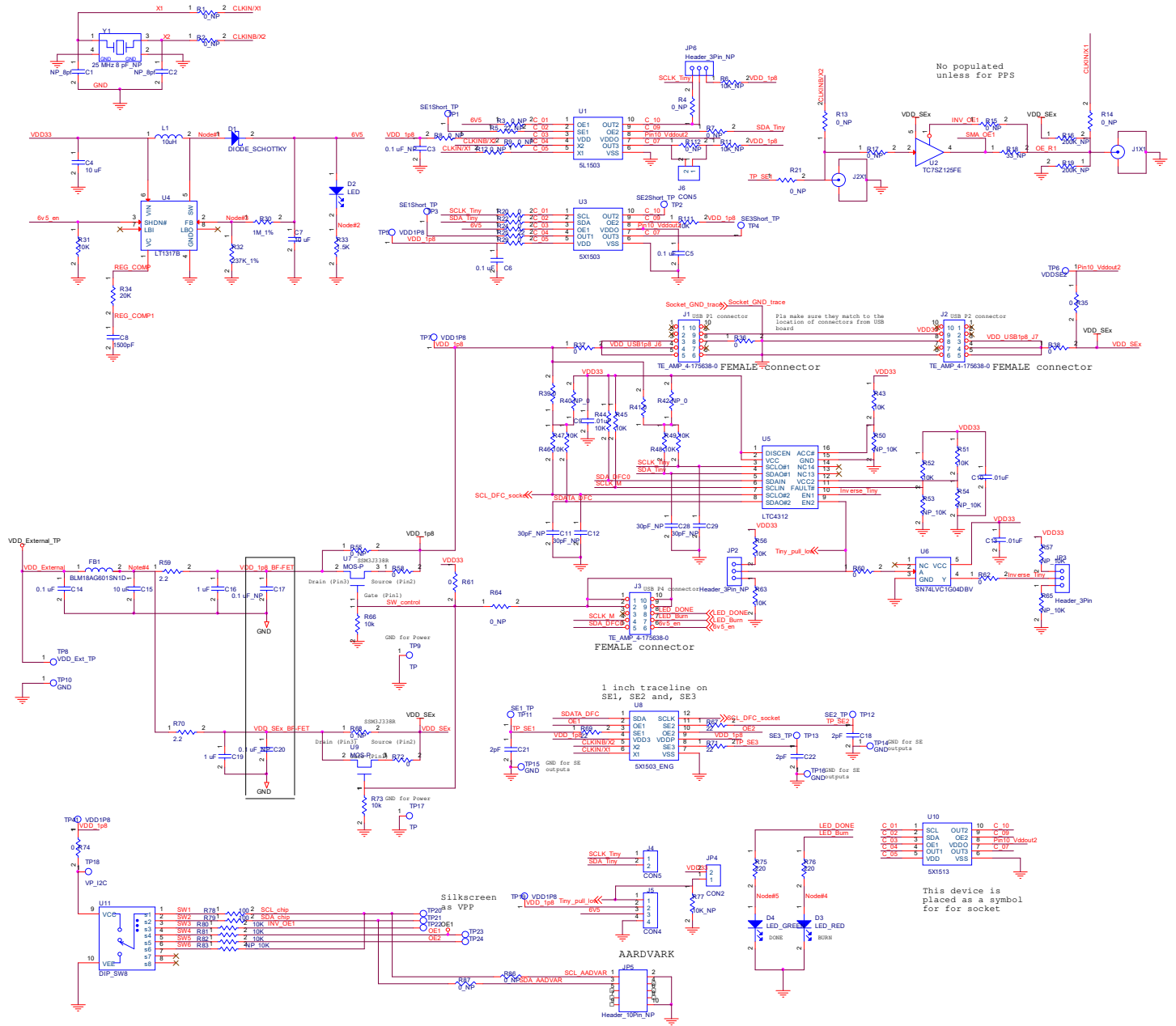

Figure 13. Development Kit Evaluation Board Schematic

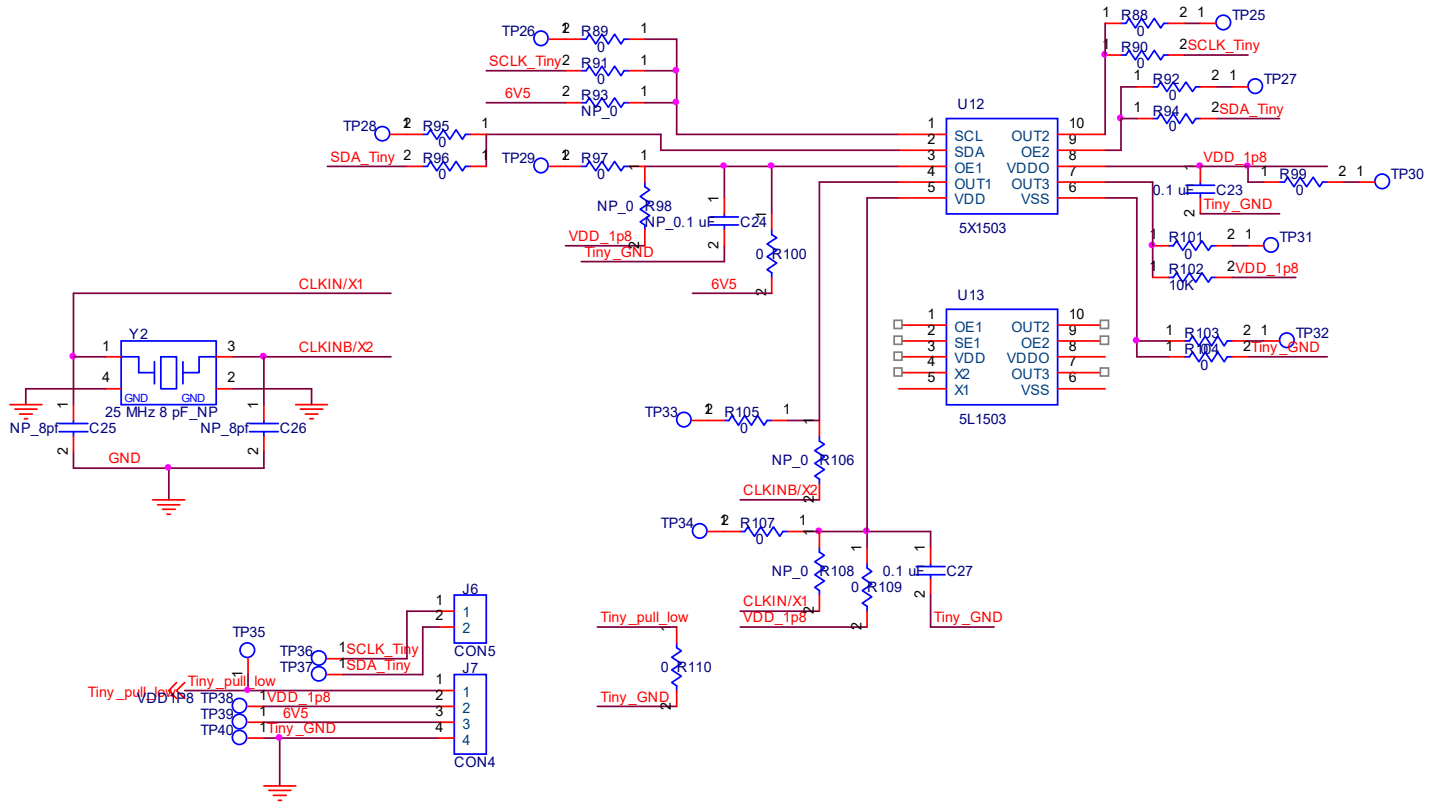

Figure 14. 5X1503 Socket Board (board populated with a 52MHz crystal for evaluation)

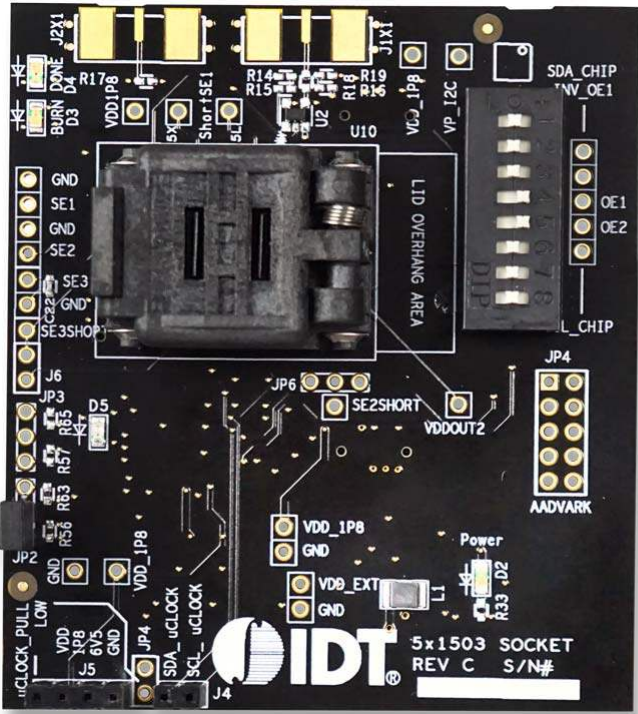

Figure 15. 5L1503 Socket Board (board populated with a 25MHz crystal for evaluation)

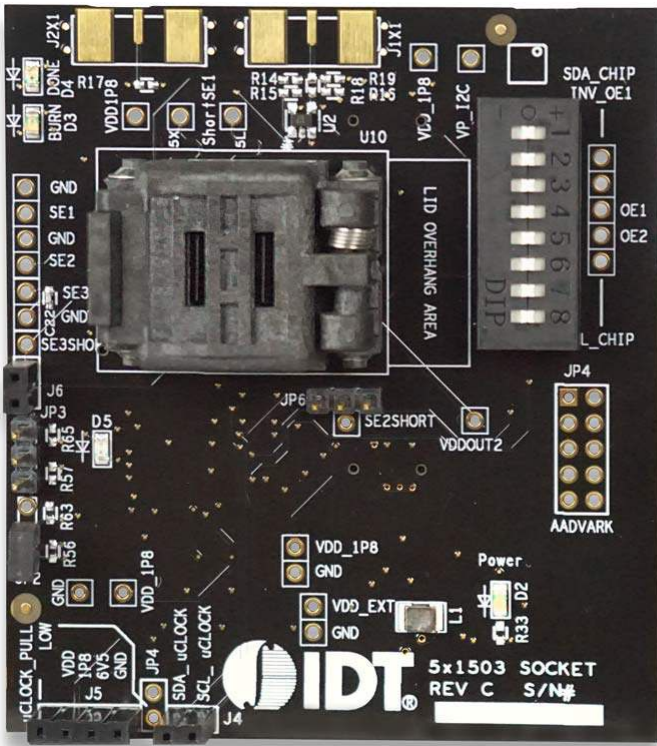

Figure 16. 5X1503 Evaluation Board (board without a crystal)

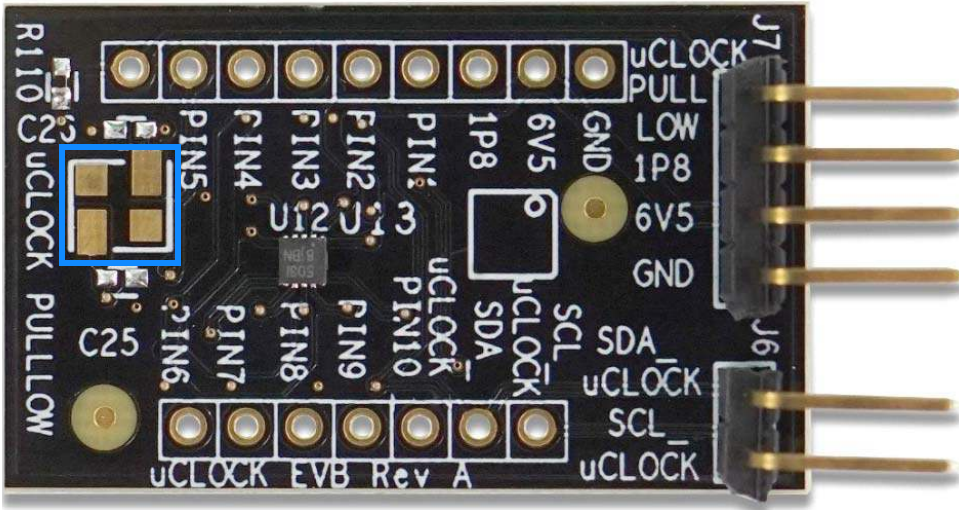
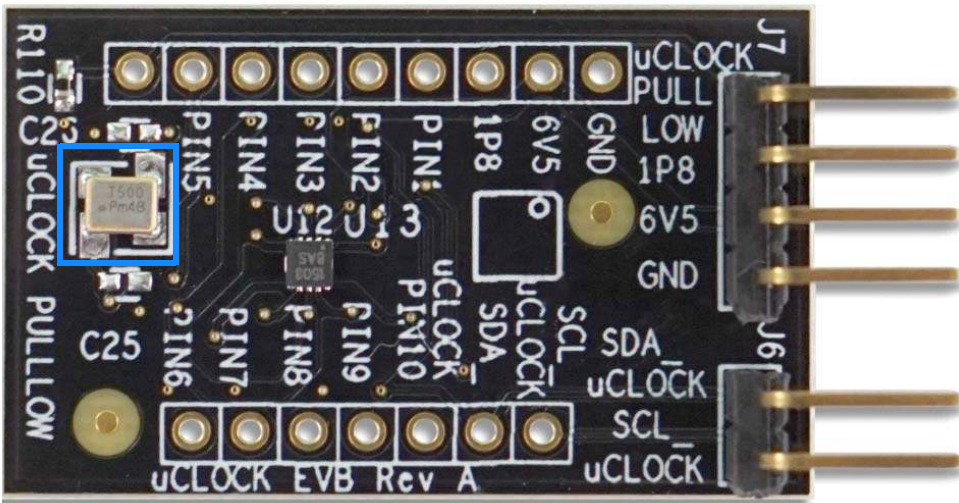

Figure 17. 5L1503 Evaluation Board (board populated with a 25MHz crystal)



Ordering Information

Orderable Part Number	Description
DEV5L1503	Development Kit for the 5L1503 (standard 5L1503).
DEV5X1503	Development Kit for the 5X1503 (standard 5X1503).
EVB5L1503	5L1503 series tiny evaluation board.
EVB5X1503	5X1503 series tiny valuation board.

Revision History

Revision Date	Description of Change
July 24, 2019	Updated Socket Board Overview figure and descriptions.
July 8, 2019	Initial release.

IMPORTANT NOTICE AND DISCLAIMER

RENESAS ELECTRONICS CORPORATION AND ITS SUBSIDIARIES (“RENESAS”) PROVIDES TECHNICAL SPECIFICATIONS AND RELIABILITY DATA (INCLUDING DATASHEETS), DESIGN RESOURCES (INCLUDING REFERENCE DESIGNS), APPLICATION OR OTHER DESIGN ADVICE, WEB TOOLS, SAFETY INFORMATION, AND OTHER RESOURCES “AS IS” AND WITH ALL FAULTS, AND DISCLAIMS ALL WARRANTIES, EXPRESS OR IMPLIED, INCLUDING, WITHOUT LIMITATION, ANY IMPLIED WARRANTIES OF MERCHANTABILITY, FITNESS FOR A PARTICULAR PURPOSE, OR NON-INFRINGEMENT OF THIRD PARTY INTELLECTUAL PROPERTY RIGHTS.

These resources are intended for developers skilled in the art designing with Renesas products. You are solely responsible for (1) selecting the appropriate products for your application, (2) designing, validating, and testing your application, and (3) ensuring your application meets applicable standards, and any other safety, security, or other requirements. These resources are subject to change without notice. Renesas grants you permission to use these resources only for development of an application that uses Renesas products. Other reproduction or use of these resources is strictly prohibited. No license is granted to any other Renesas intellectual property or to any third party intellectual property. Renesas disclaims responsibility for, and you will fully indemnify Renesas and its representatives against, any claims, damages, costs, losses, or liabilities arising out of your use of these resources. Renesas' products are provided only subject to Renesas' Terms and Conditions of Sale or other applicable terms agreed to in writing. No use of any Renesas resources expands or otherwise alters any applicable warranties or warranty disclaimers for these products.

(Disclaimer Rev.1.0 Mar 2020)

Corporate Headquarters

TOYOSU FORESIA, 3-2-24 Toyosu,
Koto-ku, Tokyo 135-0061, Japan
www.renesas.com

Contact Information

For further information on a product, technology, the most up-to-date version of a document, or your nearest sales office, please visit:
www.renesas.com/contact/

Trademarks

Renesas and the Renesas logo are trademarks of Renesas Electronics Corporation. All trademarks and registered trademarks are the property of their respective owners.