

1

2

3

4

5

6

7

A

B

C

D

E

F

A

B

C

D

E

F

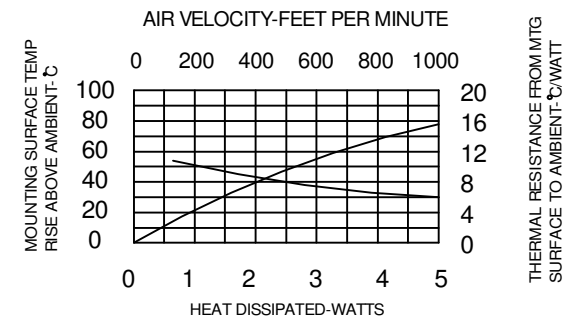
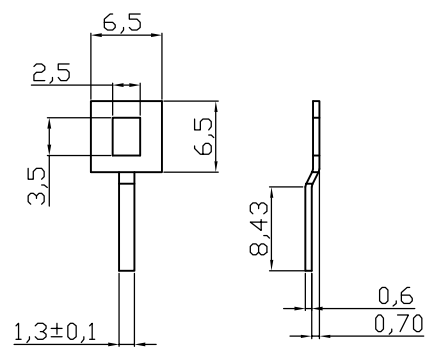
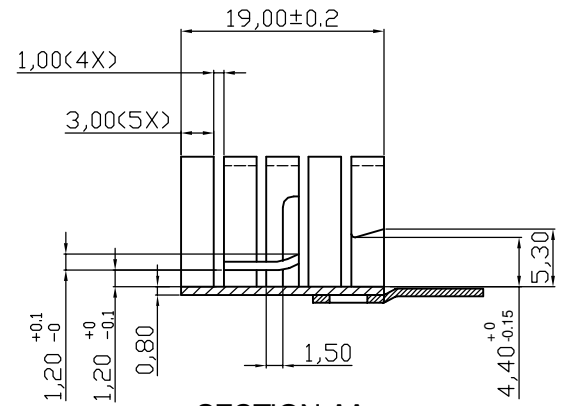
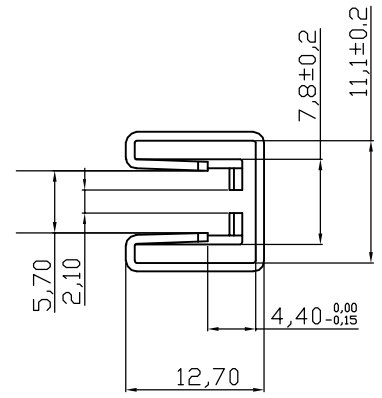
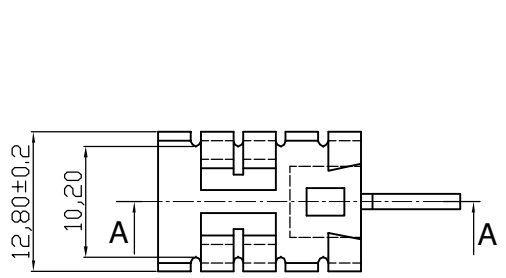

Notes
 Material : AL 5052 T=0.8±0.1 MM
 Finished : Black Anodize

② Thermal resistance : 21 K/W
 Weight : 0,001KG

RoHS compliant
 UNIT: mm

Scale	FREE					Date	Name	Customer-No.
TOLERANCE						Drawn	20.07.2006	Storb
UNIT	±0.5					Approved	09.09.2011	Andy
		②	Update	09.09.2011	Schulz			
		①	Update	29.06.2011	Schulz			
		①	Drawn	20.07.2006	Storb			
DIM	TOL	Id.	Modification	Date	Name			
X.°	±X°							
X.X°	±X°							
Angle	TOL							

Customer-No.		
ASSMANN WSW-No.		V8508B-L
Drawing-No.	ASS 0555 HS	rev02
Replace		Sheet

1

2

3

4

5

6

7

H

H