

TOSHIBA Bi-CMOS Integrated Circuit Silicon Monolithic

TB6561FG

Dual Full-Bridge Driver IC for DC Motors

The TB6561FG is a dual bridge driver IC for DC brush motor that contains MOS transistors in an output stage.

By using low ON-resistance MOS transistors and PWM current control circuitry, the driver achieves high efficiency.

Features

- Power supply voltage: 40 V (max)
- Output current: 1.5 A (max)
- Low ON-resistance: 1.5 Ω (upper and lower transistors/typ.)
- Direct PWM current control system
- Power-saving function
- Forward/reverse/short brake/stop modes
- Over-current protection: $I_{LIM} = 2.5$ A (typ.)
- Thermal shutdown
- Package: SSOP30-P-375-1.00

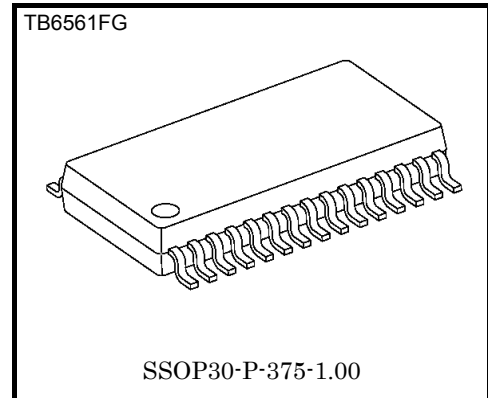

Weight: 0.63g (typ.)

The following conditions apply to solderability:

About solderability, following conditions were confirmed

(1) Use of Sn-37Pb solder Bath

·solder bath temperature: 230°C

·dipping time: 5 seconds

·the number of times: once

·use of R-type flux

(2) Use of Sn-3.0Ag-0.5Cu solder Bath

·solder bath temperature: 245°C

·dipping time: 5 seconds

·the number of times: once

·use of R-type flux

Block Diagram

Some of the functional blocks, circuits and constants in the block diagram may be omitted or simplified for explanatory purposes.

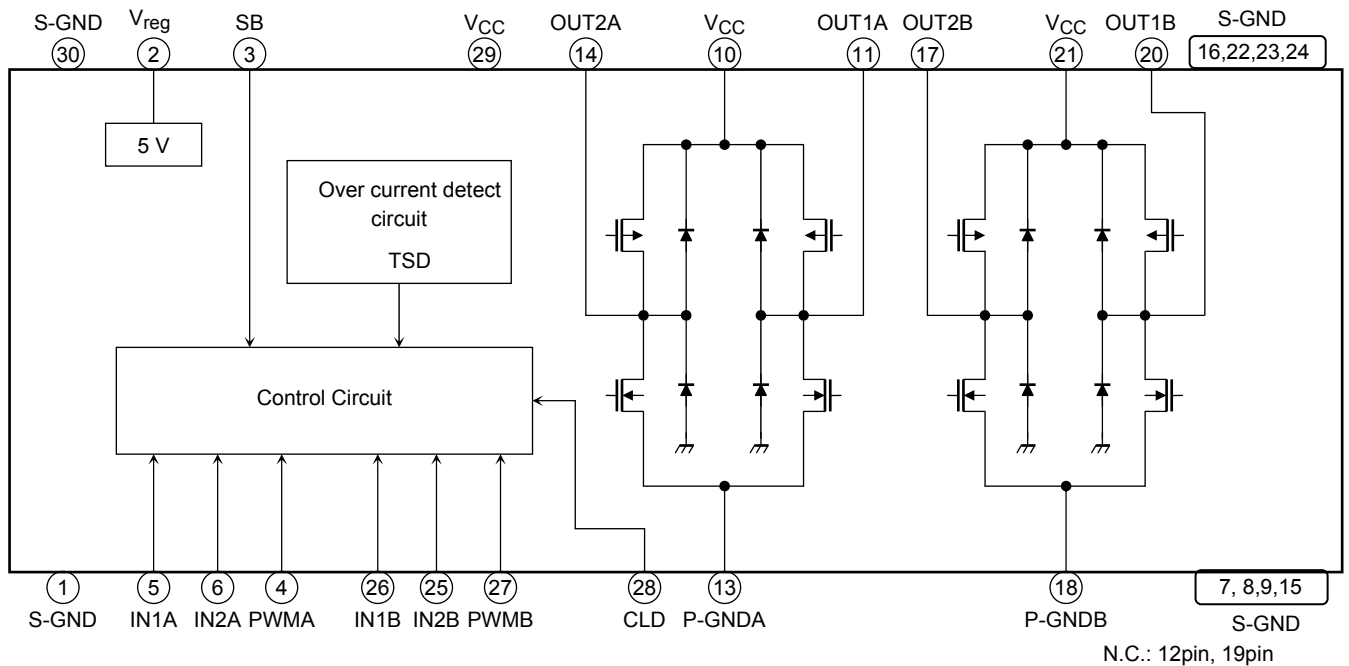

Absolute Maximum Ratings ($T_a = 25^\circ\text{C}$)

Characteristics	Symbol	Rating	Unit
Power supply voltage	V_{CC}	40	V
Output voltage	V_O	40 (Note 1)	V
Output current	I_O (Peak)	1.5 (Note 2)	A
Input voltage	V_{IN}	-0.3 to 5.5	V
Power dissipation	P_D	2.5 (Note 3)	W
Operating temperature	T_{opr}	-20 to 85	$^\circ\text{C}$
Storage temperature	T_{stg}	-55 to 150	$^\circ\text{C}$

The absolute maximum ratings of a semiconductor device are a set of specified parameter values that must not be exceeded during operation, even for an instant.

If any of these ratings are exceeded during operation, the electrical characteristics of the device may be irreparably altered, in which case the reliability and lifetime of the device can no longer be guaranteed.

Moreover, any exceeding of the ratings during operation may cause breakdown, damage and/or degradation in other equipment. Applications using the device should be designed so that no maximum rating will ever be exceeded under any operating condition.

Note 1: Please use output voltage within the above absolute maximum rating, 40 V, in which includes back-EMF voltage.

Note 2: The output current may be subject to the duty cycle, ambient temperature and heatsink. Ensure that the junction temperature does not exceed 150 $^\circ\text{C}$ (max).

Note 3: When mounted on a board (50 mm \times 50 mm \times 1.6 mm, Cu area: 70 %)

Operating Range ($T_a = 25^\circ\text{C}$)

Characteristics	Symbol	Rating	Unit
Power supply voltage	V_{CC}	10 to 36	V

Pin Description

Pin No.	Symbol	Function Description	Remarks
1	S-GND	Signal ground	—
2	V _{reg}	5 V output pin	Connect a capacitor (0.1 μF) between this pin and S-GND pin.
3	SB	Standby pin	High: Start, Low: Standby, Built in pull-down resistance (100 kΩ (typ.)).
4	PWMA	Rotation direction control pin (chA)	Apply a 0-V/5-V signal, Built in pull-down resistance (100 kΩ (typ.)).
5	IN1A	Input pin 1 (chA)	Apply a 0-V/5-V signal, Built in pull-down resistance (100 kΩ (typ.)).
6	IN2A	Input pin 2 (chA)	Apply a 0-V/5-V signal, Built in pull-down resistance (100 kΩ (typ.)).
7	S-GND	Signal ground	—
8	S-GND	Signal ground	—
9	S-GND	Signal ground	—
10	V _{CC}	Power supply voltage input pin for motor drive (chA)	V _{CC (opr)}} = 10 V to 36 V
11	OUT1A	Output pin 1 (chA)	Connect to a motor coil pin.
12	N.C.	—	—
13	P-GNDA	Power ground for chA output	—
14	OUT2 A	Output pin 2 (chA)	Connect to a motor coil pin.
15	S-GND	Signal ground	—
16	S-GND	Signal ground	—
17	OUT2B	Output pin 2 (chB)	Connect to a motor coil pin.
18	P-GNDB	Power ground for chB output	—
19	N.C.	—	—
20	OUT1B	Output pin 1 (chB)	Connect to a motor coil pin.
21	V _{CC}	Power supply voltage input pin for motor drive (chB)	V _{CC (opr)}} = 10 V to 36 V
22	S-GND	Signal ground	—
23	S-GND	Signal ground	—
24	S-GND	Signal ground	—
25	IN2B	Input pin used to set output current level (chB)	Input 0-V/5-V signal, Built in pull-down resistance (100 kΩ (typ.)).
26	IN1B	Input pin used to set output current level (chB)	Input 0-V/5-V signal, Built in pull-down resistance (100 kΩ (typ.)).
27	PWM B	Rotation direction control pin (chB)	Input 0-V/5-V signal, Built in pull-down resistance (100 kΩ (typ.)).
28	CLD	Output signal pin of current limiter detection	—
29	V _{CC}	Power supply voltage input pin	V _{CC (opr)}} = 10 V to 36 V
30	S-GND	Signal ground	—

Electrical Characteristics (V_{CC} = 24 V, T_a = 25°C)

Characteristics		Symbol	Test Circuit	Test Condition	Min	Typ.	Max	Unit
Supply current		I _{CC1}	—	Stop mode	—	5.5	10	mA
		I _{CC2}		Forward/Reverse mode	—	5.0	9	
		I _{CC3}		Short brake mode	—	5.5	10	
		I _{CC4}		Standby mode	—	1.5	3	
Control circuit	Input voltage	V _{INH}	—	—	2.3	—	5.5	V
		V _{INL}		—	−0.2	—	0.8	
	Hysteresis voltage	V _{IN (HYS)}	—	(Design guarantee)	—	0.4	—	
	Input current	I _{INH}	—	V _{IN} = 5 V	30	50	75	μA
I _{INL}		V _{IN} = 0 V		—	—	5		
PWM input circuit	Input voltage	V _{PWMH}	—	—	2.3	—	5.5	V
		V _{PWML}		—	−0.2	—	0.8	
	Hysteresis voltage	V _{PWM (HYS)}	—	(Design guarantee)	—	0.4	—	
	Input current	I _{PWMH}	—	V _{PWM} = 5 V	30	50	75	μA
		I _{PWML}		V _{PWM} = 0 V	—	—	5	
PWM frequency	f _{PWM}	—	Duty: 50 %	—	—	100	kHz	
Standby circuit	Input voltage	V _{INSH}	—	—	2.3	—	5.5	V
		V _{INSL}		—	−0.2	—	0.8	
	Hysteresis voltage	V _{IN (HYS)}	—	(Design guarantee)	—	0.4	—	
	Input current	I _{INSH}	—	V _{IN} = 5 V	30	50	75	μA
		I _{INSL}		V _{IN} = 0 V	—	—	5	
Output ON resistance	R _{on (U+L)}	—	I _O = 0.2 A	—	1.5	2.0	Ω	
			I _O = 1.5 A	—	1.5	2.0		
Output leakage current	I _{L (U)}	—	V _{CC} = 40 V	—	—	10	μA	
	I _{L (L)}		V _{CC} = 40 V	—	—	10		
Diode forward voltage	V _{F (U)}	—	I _O = 1.5 A	—	1.3	2.0	V	
	V _{F (L)}		I _O = 1.5 A	—	1.3	2.0		
Internal reference voltage	V _{reg}	—	I _{reg} = 1 mA	4.75	5	5.25	V	
Output signal of current limiter detection	V _{CLD(H)}	—	I _O = 50 μA	4.25	—	V _{reg}	V	
	V _{CLD(L)}	—		—	—	0.5		
Offset time for current limiter	I _{SD (OFF)}	—	(Design guarantee)	—	50	—	μs	
Thermal shutdown circuit operating temperature	T _{SD}	—	(Design guarantee)	—	160	—	°C	

Input/Output Function

Input				Output		
IN1	IN2	SB	PWM	OUT1	OUT2	Mode
H	H	H	H	L	L	Short brake
			L			
L	H	H	H	L	H	CW/CCW
			L	L	L	Short brake
H	L	H	H	H	L	CCW/CW
			L	L	L	Short brake
L	L	H	H	OFF (high-impedance)		Stop
			L			
H/L	H/L	L	H	OFF (high-impedance)		Standby
			L			

Current Limiter Detection Circuit (CLD)

The CLD pin outputs the states of the current limiter and thermal shutdown circuits. If the current limiter for either channel A or B or the thermal shutdown circuit (shared for both channels) operates, the CLD pin state changes from low (normal state) to high.

The CLD circuit supports automatic recovery; its output returns to low once the current decreases to a value below the limit or once the thermal shutdown state is released.

Mode	CLD Output
Under TSD operation and current detection	H
Normal	L

< When current limiter operated >

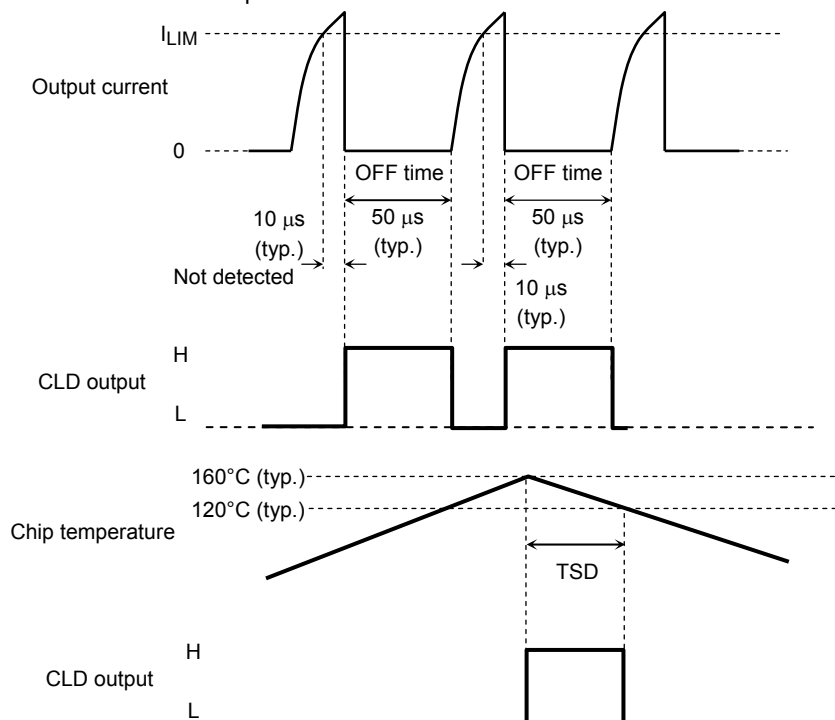

- PWM control function

Applying a PWM signal of 0/5 V to the PWM pin allows motor speed control.

The IC enters CW (CCW) mode and short brake mode alternately in PWM current control.

To prevent shoot-through current caused by simultaneous conduction of upper and lower transistors in the output stage, a dead time is internally generated for 300 ns (target spec) when switching the upper and lower transistors.

Therefore, synchronous rectification for high efficiency in PWM current control can be achieved without an off-time that is generated via an external input.

Even when toggling between CW and CCW modes, and CW (CCW) and short brake modes, the off-time is not required due to the internally generated dead time.

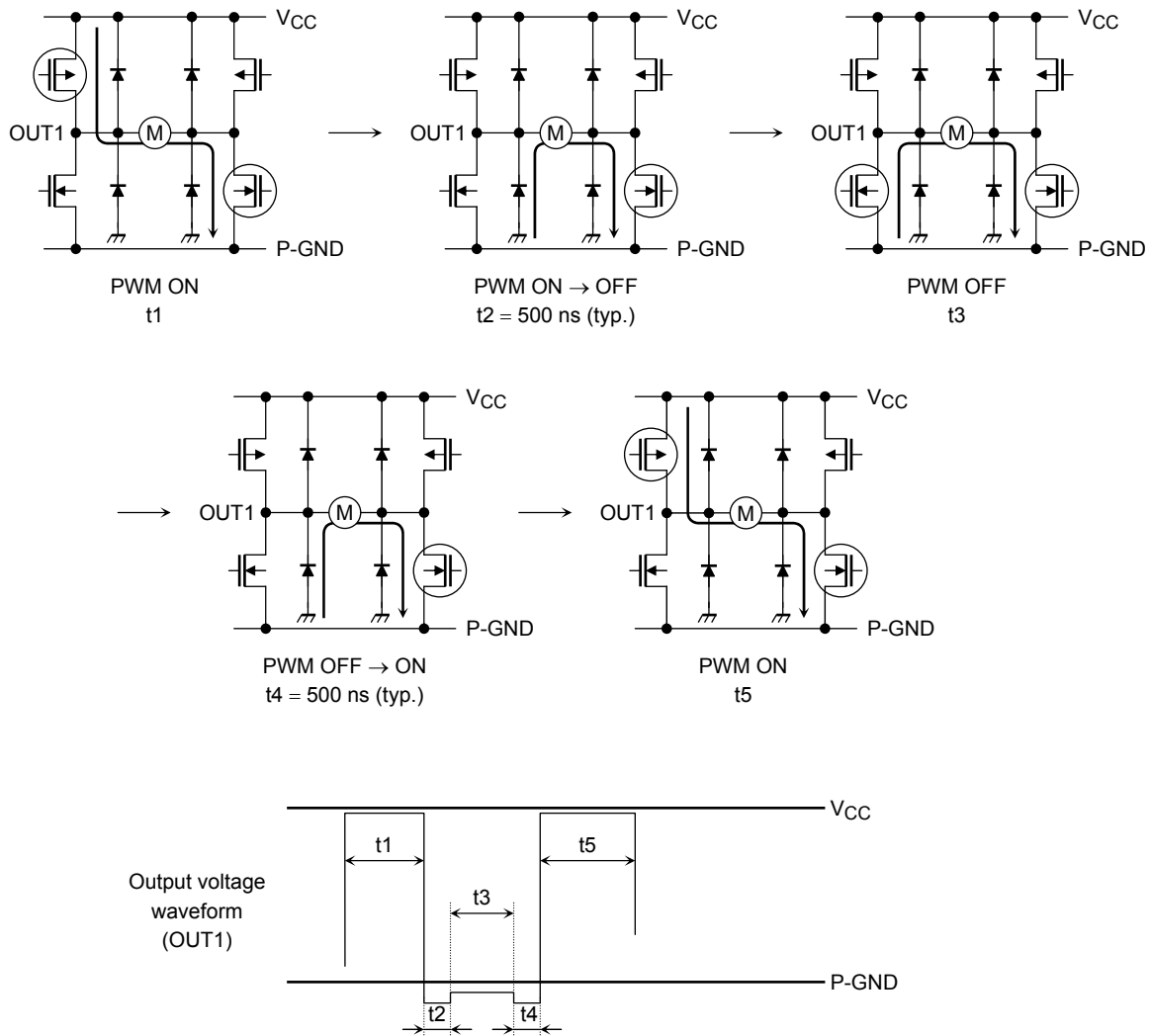

Thermal Shutdown Circuit (TSD)

The IC incorporates a thermal shutdown circuit. When the junction temperature (T_j) reaches 160°C (typ.), the output transistors are turned off.

After 50 μs (typ.), the output transistors are turned on automatically.

The IC has 40°C of temperature hysteresis.

$T_{SD} = 160^\circ\text{C}$ (target spec)

$\Delta T_{SD} = 40^\circ\text{C}$ (target spec)

Overcurrent Protection Circuit (ISD)

The IC incorporates an overcurrent protection circuit to detect voltage that flows through the output transistors. The overcurrent threshold is 2.5 A (typ.).

Currents that flow through the output transistors are monitored individually. If overcurrent is detected in at least one of the transistors, all transistors are turned off.

The IC incorporates a timer to count 50 μs (typ.) for which the transistors are off. After 50 μs, they are turned on automatically. If an overcurrent occurs again, the same operation is repeated. To prevent false detection due to glitch, the circuit turns off the transistors only when current that exceeds the overcurrent threshold flows for 10 μs or longer.

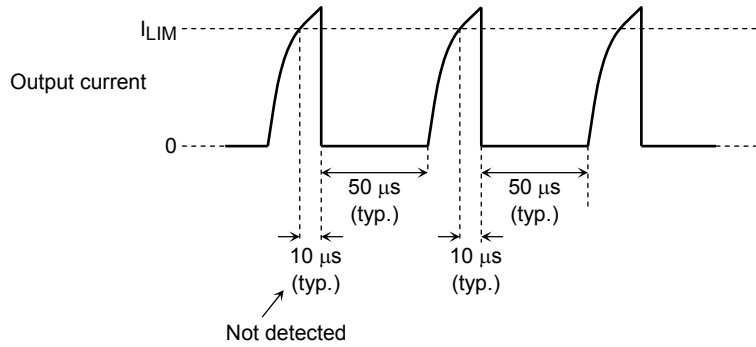

The over-current threshold is a target spec. It varies in a range from approximately 1.5 A to 3.5 A.

- These protection features are provided to temporarily avoid abnormal conditions such as output short circuits and are not guaranteed to prevent the IC from being damaged.
- These features do not operate outside the guaranteed operating ranges and the IC may be permanently damaged in case of output short circuits.
- The overcurrent protection is only provided to protect the IC from temporary short circuits. If a short-circuit condition persists for a long time, it may cause excessive stress and damage to the IC. The protection system should be configured so that any overcurrent condition will be eliminated as soon as possible.

OUTPUT UPPER SIDE $I_{out} - V_{CE(sat)}$ <Reference data>

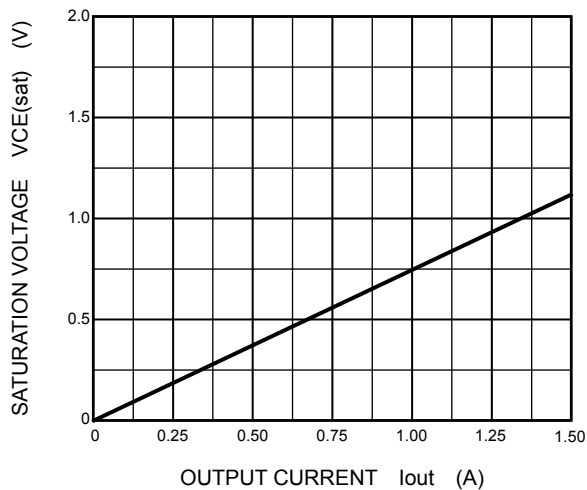

OUTPUT LOWER SIDE $I_{out} - V_{CE(sat)}$ <Reference data>

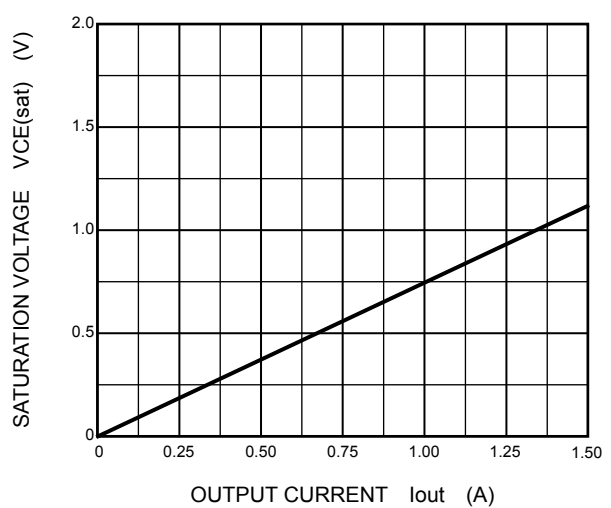

Application Circuit

The application circuits shown in this document are provided for reference purposes only. Thorough evaluation is required, especially at the mass production design stage.

Toshiba does not grant any license to any industrial property rights by providing these examples of application circuits.

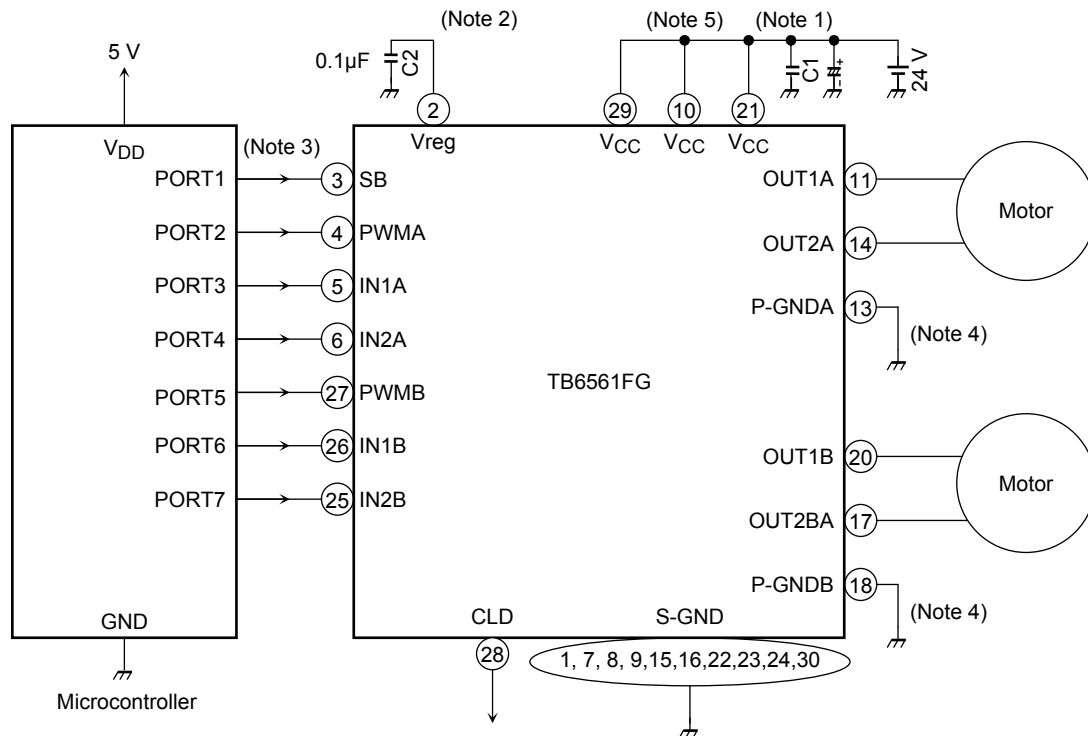

Note 1: A power supply capacitor should be connected between V_{CC} and P-GND as close as possible to the IC.

Note 2: C2 should be connected as close as possible to S-GND.

Note 3: When the power is turned on, set SB for low (standby mode) or IN1 and IN2 for low (stop mode).

Note 4: Avoid connecting the resistor to detect the motor current. If necessary, connect the resistor to V_{CC} line.

Note 5: V_{CC} (10 pin, 21 pin, 29 pin) should be shorted externally.

Caution for using

- Utmost care is necessary in the design of the output, V_{CC} , and GND lines since the IC may be destroyed by short-circuiting between outputs, air contamination faults, or faults due to improper grounding, or by short-circuiting between contiguous pins.
- The IC may be destroyed when mounted in the wrong orientation. Thus, please mount it with great care.

Package Dimensions

SSOP30-P-375-1.00

Unit : mm

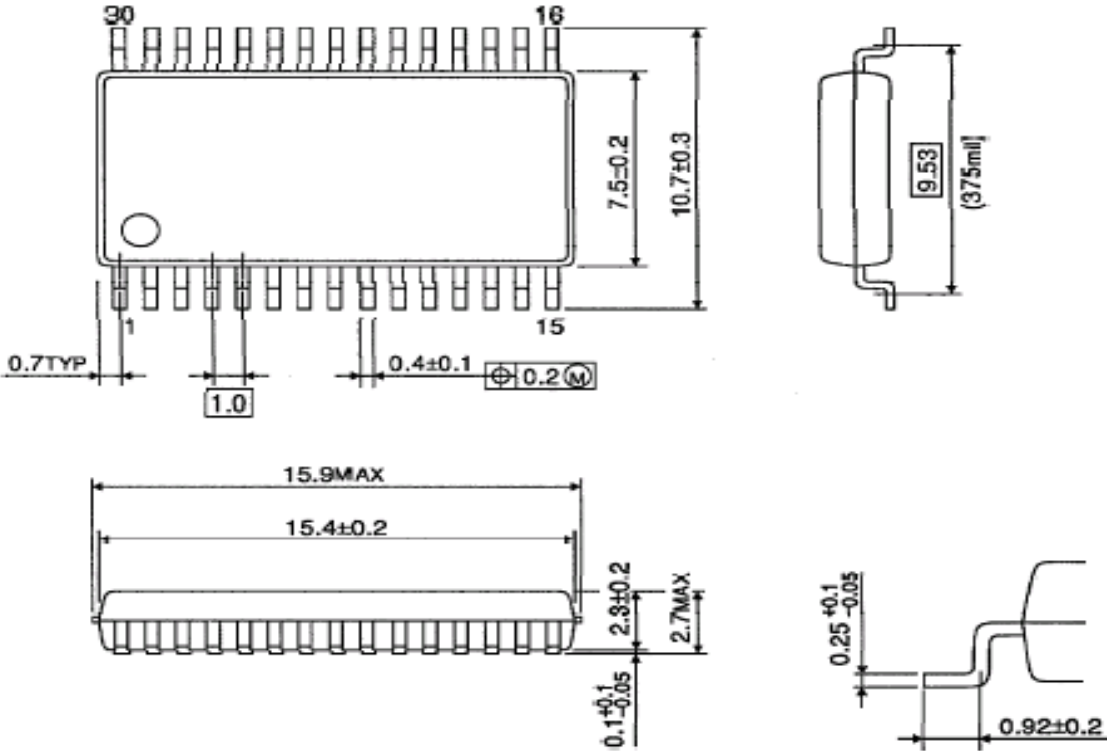

Weight: 0.63 g (typ.)

Notes on Contents

1. Block Diagrams

Some of the functional blocks, circuits, or constants in the block diagram may be omitted or simplified for explanatory purposes.

2. Equivalent Circuits

The equivalent circuit diagrams may be simplified or some parts of them may be omitted for explanatory purposes.

3. Timing Charts

Timing charts may be simplified for explanatory purposes.

4. Application Circuits

The application circuits shown in this document are provided for reference purposes only. Thorough evaluation is required, especially at the mass production design stage.

Toshiba does not grant any license to any industrial property rights by providing these examples of application circuits.

5. Test Circuits

Components in the test circuits are used only to obtain and confirm the device characteristics. These components and circuits are not guaranteed to prevent malfunction or failure from occurring in the application equipment.

IC Usage Considerations

Notes on handling of ICs

- [1] The absolute maximum ratings of a semiconductor device are a set of ratings that must not be exceeded, even for a moment. Do not exceed any of these ratings.
Exceeding the rating(s) may cause the device breakdown, damage or deterioration, and may result injury by explosion or combustion.
- [2] Use an appropriate power supply fuse to ensure that a large current does not continuously flow in case of over current and/or IC failure. The IC will fully break down when used under conditions that exceed its absolute maximum ratings, when the wiring is routed improperly or when an abnormal pulse noise occurs from the wiring or load, causing a large current to continuously flow and the breakdown can lead smoke or ignition. To minimize the effects of the flow of a large current in case of breakdown, appropriate settings, such as fuse capacity, fusing time and insertion circuit location, are required.
- [3] If your design includes an inductive load such as a motor coil, incorporate a protection circuit into the design to prevent device malfunction or breakdown caused by the current resulting from the inrush current at power ON or the negative current resulting from the back electromotive force at power OFF. IC breakdown may cause injury, smoke or ignition.
Use a stable power supply with ICs with built-in protection functions. If the power supply is unstable, the protection function may not operate, causing IC breakdown. IC breakdown may cause injury, smoke or ignition.
- [4] Do not insert devices in the wrong orientation or incorrectly.
Make sure that the positive and negative terminals of power supplies are connected properly. Otherwise, the current or power consumption may exceed the absolute maximum rating, and exceeding the rating(s) may cause the device breakdown, damage or deterioration, and may result injury by explosion or combustion.
In addition, do not use any device that is applied the current with inserting in the wrong orientation or incorrectly even just one time.

Points to remember on handling of ICs**(1) Over current Protection Circuit**

Over current protection circuits (referred to as current limiter circuits) do not necessarily protect ICs under all circumstances. If the Over current protection circuits operate against the over current, clear the over current status immediately.

Depending on the method of use and usage conditions, such as exceeding absolute maximum ratings can cause the over current protection circuit to not operate properly or IC breakdown before operation. In addition, depending on the method of use and usage conditions, if over current continues to flow for a long time after operation, the IC may generate heat resulting in breakdown.

(2) Thermal Shutdown Circuit

Thermal shutdown circuits do not necessarily protect ICs under all circumstances. If the thermal shutdown circuits operate against the over temperature, clear the heat generation status immediately.

Depending on the method of use and usage conditions, such as exceeding absolute maximum ratings can cause the thermal shutdown circuit to not operate properly or IC breakdown before operation.

(3) Heat Radiation Design

In using an IC with large current flow such as power amp, regulator or driver, please design the device so that heat is appropriately radiated, not to exceed the specified junction temperature (T_J) at any time and condition. These ICs generate heat even during normal use. An inadequate IC heat radiation design can lead to decrease in IC life, deterioration of IC characteristics or IC breakdown. In addition, please design the device taking into consideration the effect of IC heat radiation with peripheral components.

(4) Back-EMF

When a motor rotates in the reverse direction, stops or slows down abruptly, a current flow back to the motor's power supply due to the effect of back-EMF. If the current sink capability of the power supply is small, the device's motor power supply and output pins might be exposed to conditions beyond maximum ratings. To avoid this problem, take the effect of back-EMF into consideration in system design.

RESTRICTIONS ON PRODUCT USE

- Toshiba Corporation, and its subsidiaries and affiliates (collectively "TOSHIBA"), reserve the right to make changes to the information in this document, and related hardware, software and systems (collectively "Product") without notice.
- This document and any information herein may not be reproduced without prior written permission from TOSHIBA. Even with TOSHIBA's written permission, reproduction is permissible only if reproduction is without alteration/omission.
- Though TOSHIBA works continually to improve Product's quality and reliability, Product can malfunction or fail. Customers are responsible for complying with safety standards and for providing adequate designs and safeguards for their hardware, software and systems which minimize risk and avoid situations in which a malfunction or failure of Product could cause loss of human life, bodily injury or damage to property, including data loss or corruption. Before customers use the Product, create designs including the Product, or incorporate the Product into their own applications, customers must also refer to and comply with (a) the latest versions of all relevant TOSHIBA information, including without limitation, this document, the specifications, the data sheets and application notes for Product and the precautions and conditions set forth in the "TOSHIBA Semiconductor Reliability Handbook" and (b) the instructions for the application with which the Product will be used with or for. Customers are solely responsible for all aspects of their own product design or applications, including but not limited to (a) determining the appropriateness of the use of this Product in such design or applications; (b) evaluating and determining the applicability of any information contained in this document, or in charts, diagrams, programs, algorithms, sample application circuits, or any other referenced documents; and (c) validating all operating parameters for such designs and applications. **TOSHIBA ASSUMES NO LIABILITY FOR CUSTOMERS' PRODUCT DESIGN OR APPLICATIONS.**
- Product is intended for use in general electronics applications (e.g., computers, personal equipment, office equipment, measuring equipment, industrial robots and home electronics appliances) or for specific applications as expressly stated in this document. Product is neither intended nor warranted for use in equipment or systems that require extraordinarily high levels of quality and/or reliability and/or a malfunction or failure of which may cause loss of human life, bodily injury, serious property damage or serious public impact ("Unintended Use"). Unintended Use includes, without limitation, equipment used in nuclear facilities, equipment used in the aerospace industry, medical equipment, equipment used for automobiles, trains, ships and other transportation, traffic signaling equipment, equipment used to control combustions or explosions, safety devices, elevators and escalators, devices related to electric power, and equipment used in finance-related fields. Do not use Product for Unintended Use unless specifically permitted in this document.
- Do not disassemble, analyze, reverse-engineer, alter, modify, translate or copy Product, whether in whole or in part.
- Product shall not be used for or incorporated into any products or systems whose manufacture, use, or sale is prohibited under any applicable laws or regulations.
- The information contained herein is presented only as guidance for Product use. No responsibility is assumed by TOSHIBA for any infringement of patents or any other intellectual property rights of third parties that may result from the use of Product. No license to any intellectual property right is granted by this document, whether express or implied, by estoppel or otherwise.
- **ABSENT A WRITTEN SIGNED AGREEMENT, EXCEPT AS PROVIDED IN THE RELEVANT TERMS AND CONDITIONS OF SALE FOR PRODUCT, AND TO THE MAXIMUM EXTENT ALLOWABLE BY LAW, TOSHIBA (1) ASSUMES NO LIABILITY WHATSOEVER, INCLUDING WITHOUT LIMITATION, INDIRECT, CONSEQUENTIAL, SPECIAL, OR INCIDENTAL DAMAGES OR LOSS, INCLUDING WITHOUT LIMITATION, LOSS OF PROFITS, LOSS OF OPPORTUNITIES, BUSINESS INTERRUPTION AND LOSS OF DATA, AND (2) DISCLAIMS ANY AND ALL EXPRESS OR IMPLIED WARRANTIES AND CONDITIONS RELATED TO SALE, USE OF PRODUCT, OR INFORMATION, INCLUDING WARRANTIES OR CONDITIONS OF MERCHANTABILITY, FITNESS FOR A PARTICULAR PURPOSE, ACCURACY OF INFORMATION, OR NONINFRINGEMENT.**
- Do not use or otherwise make available Product or related software or technology for any military purposes, including without limitation, for the design, development, use, stockpiling or manufacturing of nuclear, chemical, or biological weapons or missile technology products (mass destruction weapons). Product and related software and technology may be controlled under the Japanese Foreign Exchange and Foreign Trade Law and the U.S. Export Administration Regulations. Export and re-export of Product or related software or technology are strictly prohibited except in compliance with all applicable export laws and regulations.
- Please contact your TOSHIBA sales representative for details as to environmental matters such as the RoHS compatibility of Product. Please use Product in compliance with all applicable laws and regulations that regulate the inclusion or use of controlled substances, including without limitation, the EU RoHS Directive. TOSHIBA assumes no liability for damages or losses occurring as a result of noncompliance with applicable laws and regulations.