

LOC	DIST	REV	DATE	DWN	APVD
FM	-	A2	21MAR2011	RK	HMR
		A3	11MAY2011	KWE	B.F.
		A4	19APR2012	VP	B.F.

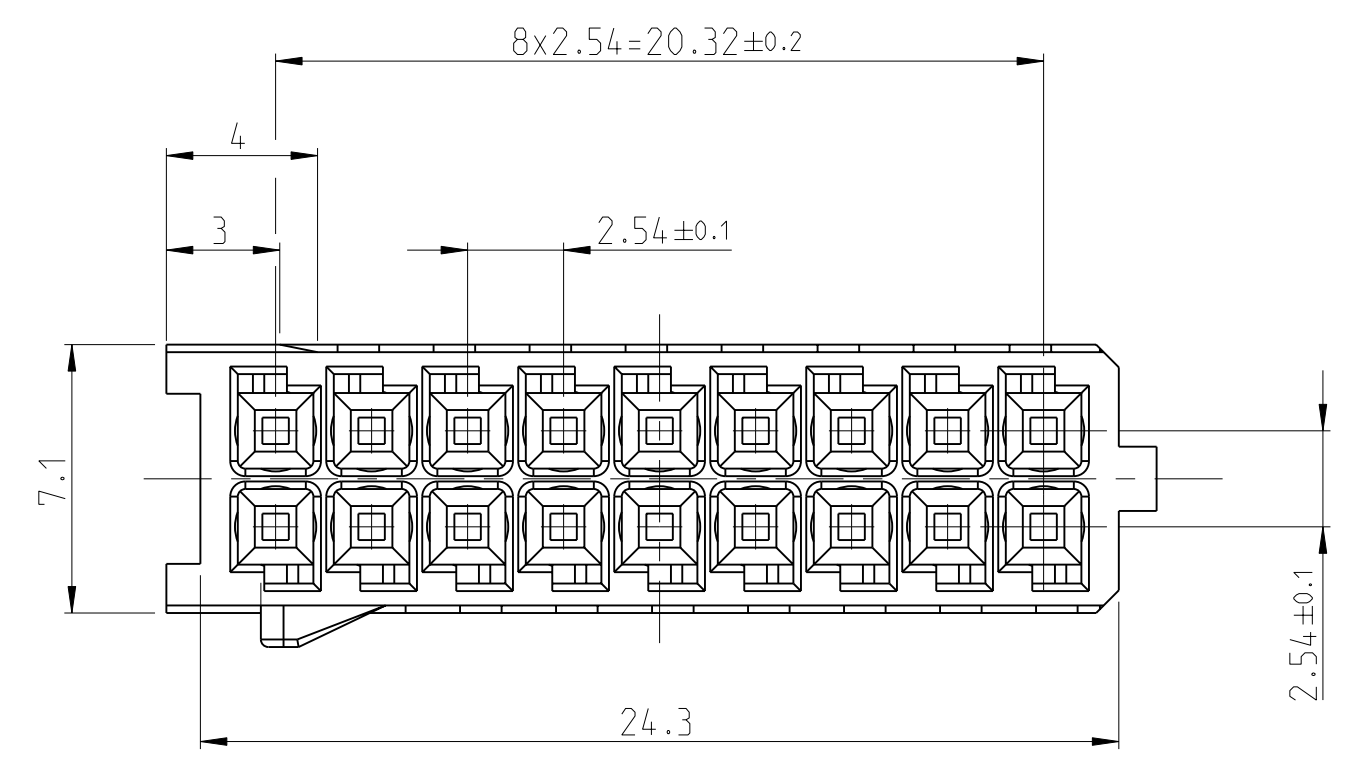
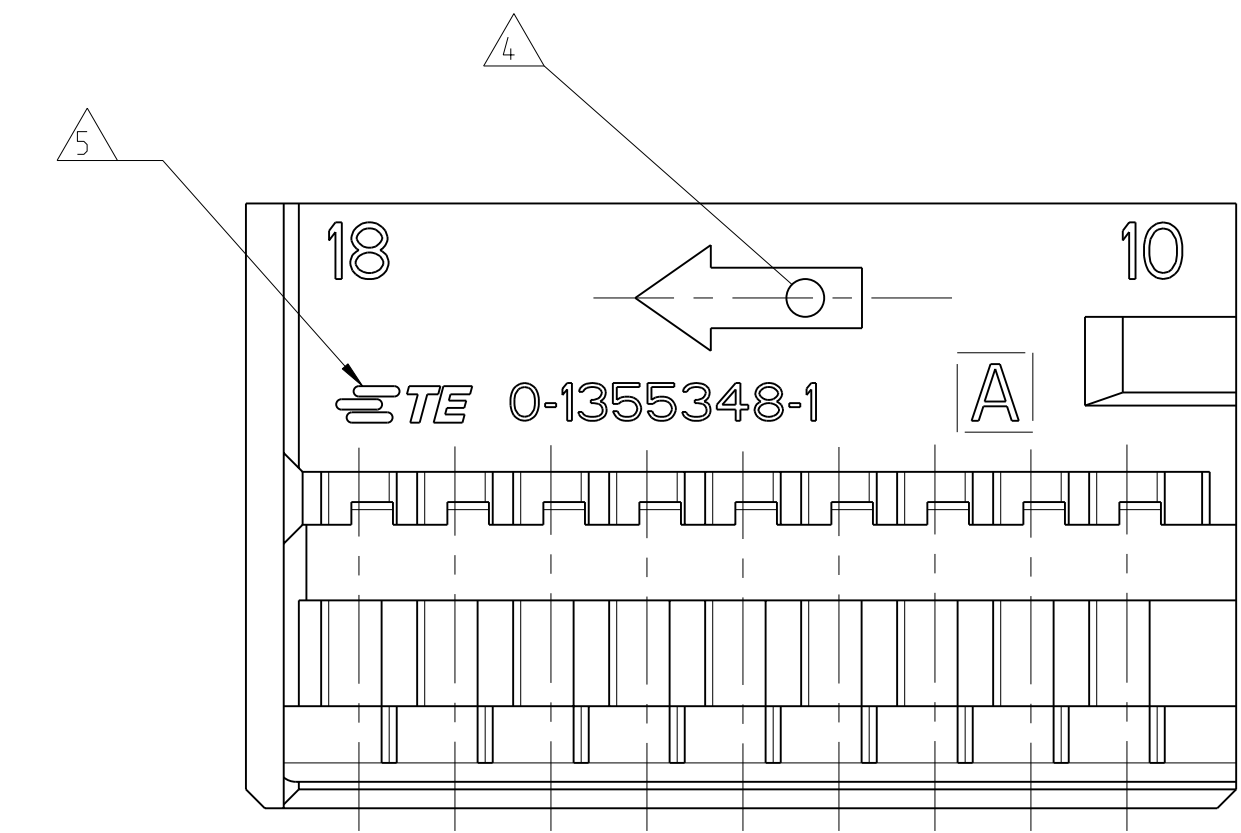
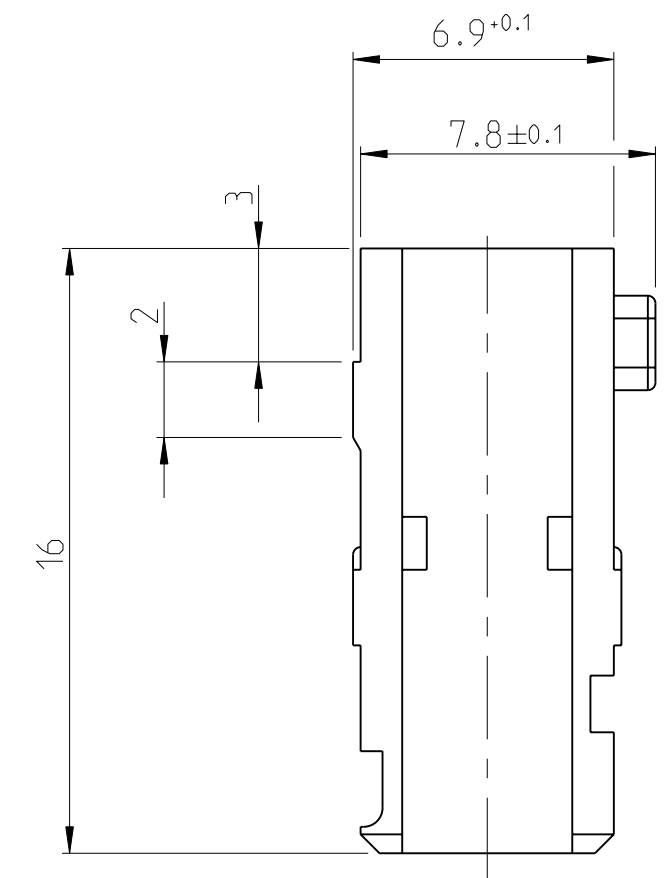
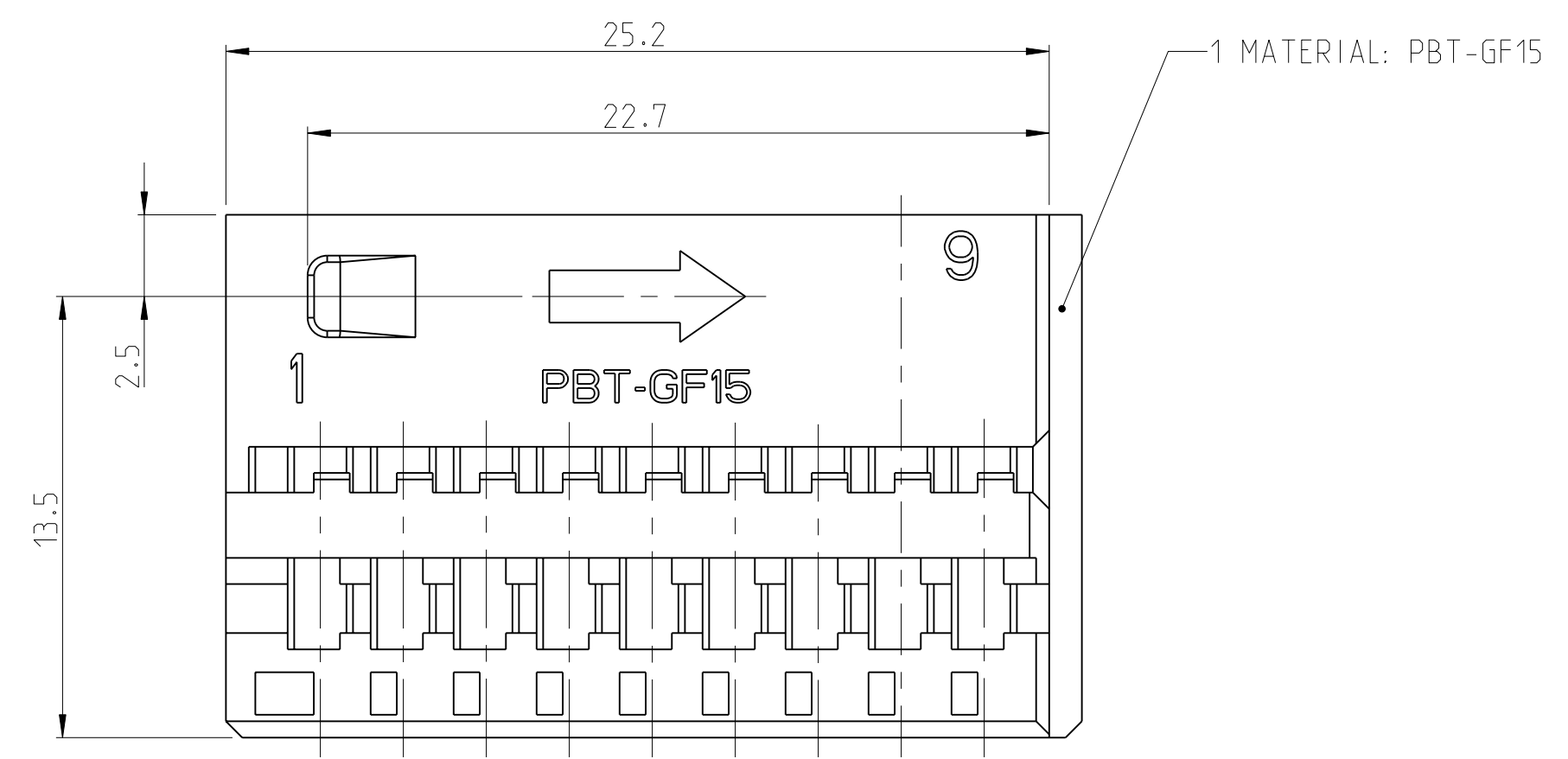

NOTES  
Bemerkungen

- 1 ASSOCIATION SEE TABLE  
Zuordnung siehe Tabelle
- 2 Produktspezifikation: 108-18157-1  
PRODUCTSPECIFICATION:108-18157-1
- 3 WIRE SIZE RANGE 0.75 mm IN ALL CAVITIES POSSIBLE  
BUT ONLY IN 4 CAVITIES PERMITTED  
Drahtgrossenbereich 0.75 mm in allen Kammern moeglich.  
jedoch nur in 4 Kammern zulaessig

- 4 CAVITY MARKING  
Nestmarkierung
- 5 TE-LOGO  
TE-Logo

	Tool 1 Werkzeug 1	Tool 2 Werkzeug 2
TE LOGO TE Logo	AMP	TE
Tool Number Werkzeugnummer		
Tool Cavity 1 Formnest 1	1	2.1
Tool Cavity 2 Formnest 2	2	2.2
Tool Cavity 3 Formnest 3	3	2.3
Tool Cavity 4 Formnest 4	4	2.4

0-1355348-1	A	/	1	1	SOCKET. HOUSING Buchsengehaeuse	BLACK schwarz	1.7	<del>4-1355350-1</del> <del>3-1355350-1</del> <del>2-1355350-1</del> <del>1-1355350-1</del>	NOT YET TOOLED
TE BESTELL-NR. ORDER NO.	REV. KOD.	COD. KOD.	POS.	QTY. STK.	DESCRIPTION BENENNUNG	OBERFLAECHE SURFACE FARBE/COLOUR	GRAMM GEWICHT WEIGHT	SUITABLE FOR/PASSEND ZU: SHIELD/Abdeckkappe TE CONNECTIVITY	

CUSTOMER PART NO	PART NO	REV	PCS	MATERIAL	SURFACE COLOUR	DESCRIPTION

THIS DRAWING IS A CONTROLLED DOCUMENT.  
 DIMENSIONING AND TOLERANCING PER GPS (ISO STANDARDS)

DIMENSIONS:  
MASSENMESSEN:  
mm

TOLERANCES UNLESS  
OTHERWISE SPECIFIED:  
ALLGEMEINTOLERANZEN

9 PLC	±0.2
1 PLC	±0.1
5 PLC	±0.2
4 PLC	±
ANGLE/SCHWELWEN	±0.2
FINISH/OBERFLAECHE/FARBE	

MATERIAL  
PBT GF15  
703457-2

WEIGHT  
GEWICHT

CUSTOMER DRAWING

DWN: D.Ebank  
31JAN2000  
BY: B.Eiebertling  
APVD:

NAME: MICRO QUADLOK SYSTEM. SOCKET HOUSING.18POS.  
Micro Quadlok System. Buchsengehaeuse.18POS.

SIZE: A1  
CAGE CODE: 100779  
DRAWING NO: 0-1355348

RESTRICTED TO  
NUR FÜR

SCALE: MASSSTAB 5:1  
SHEET: 1 OF 1  
REV: A4

