



Features

- Formerly J. W. Miller® model
- Current rating up to 2.6 A
- Inductance range: 10 μ H to 47,000 μ H
- RoHS compliant*

Applications

- DC/DC converters
- Power supplies
- Desktop notebooks
- Output chokes

BOURNS®

RL895 Series - Radial Lead RF Choke

Electrical Specifications (@ 25 °C)

Part Number	Inductance (μ H)	Tol.	Q (Min.)	Test Frequency		SRF (MHz) Typ.	DCR (Ω) Max.	I dc (mA)
				L	Q			
RL895-100M-RC	10	$\pm 20\%$	40	2.52 MHz	2.52 MHz	14	0.04	2600
RL895-120M-RC	12	$\pm 20\%$	40	2.52 MHz	2.52 MHz	13	0.04	2600
RL895-150K-RC	15	$\pm 10\%$	40	2.52 MHz	2.52 MHz	11	0.05	2100
RL895-180K-RC	18	$\pm 10\%$	40	2.52 MHz	2.52 MHz	10	0.05	2000
RL895-220K-RC	22	$\pm 10\%$	40	2.52 MHz	2.52 MHz	9.0	0.06	1700
RL895-270K-RC	27	$\pm 10\%$	40	2.52 MHz	2.52 MHz	8.0	0.06	1600
RL895-330K-RC	33	$\pm 10\%$	40	2.52 MHz	2.52 MHz	7.0	0.07	1400
RL895-390K-RC	39	$\pm 10\%$	40	2.52 MHz	2.52 MHz	6.5	0.08	1400
RL895-470K-RC	47	$\pm 10\%$	40	2.52 MHz	2.52 MHz	6.0	0.10	1300
RL895-560K-RC	56	$\pm 10\%$	30	2.52 MHz	2.52 MHz	5.5	0.11	1200
RL895-680K-RC	68	$\pm 10\%$	30	2.52 MHz	2.52 MHz	5.0	0.14	1100
RL895-820K-RC	82	$\pm 10\%$	30	2.52 MHz	2.52 MHz	4.5	0.16	1000
RL895-101K-RC	100	$\pm 10\%$	25	1.0 KHz	796 KHz	4.0	0.19	900
RL895-121K-RC	120	$\pm 10\%$	25	1.0 KHz	796 KHz	3.8	0.22	820
RL895-151K-RC	150	$\pm 10\%$	25	1.0 KHz	796 KHz	3.5	0.27	740
RL895-181K-RC	180	$\pm 10\%$	25	1.0 KHz	796 KHz	3.0	0.31	710
RL895-221K-RC	220	$\pm 10\%$	25	1.0 KHz	796 KHz	2.8	0.38	640
RL895-271K-RC	270	$\pm 10\%$	25	1.0 KHz	796 KHz	2.4	0.53	570
RL895-331K-RC	330	$\pm 10\%$	20	1.0 KHz	796 KHz	2.2	0.61	510
RL895-391K-RC	390	$\pm 10\%$	20	1.0 KHz	796 KHz	2.1	0.69	480
RL895-471K-RC	470	$\pm 10\%$	15	1.0 KHz	796 KHz	2.0	0.89	430
RL895-561K-RC	560	$\pm 10\%$	15	1.0 KHz	796 KHz	1.8	1.01	400
RL895-681K-RC	680	$\pm 10\%$	15	1.0 KHz	796 KHz	1.5	1.18	350
RL895-821K-RC	820	$\pm 10\%$	15	1.0 KHz	796 KHz	1.4	1.57	320
RL895-102K-RC	1000	$\pm 10\%$	40	1.0 KHz	252 KHz	1.3	1.84	300
RL895-122K-RC	1200	$\pm 10\%$	40	1.0 KHz	252 KHz	1.2	2.10	270
RL895-152K-RC	1500	$\pm 10\%$	45	1.0 KHz	252 KHz	1.0	2.80	230
RL895-182K-RC	1800	$\pm 10\%$	45	1.0 KHz	252 KHz	0.90	3.21	210
RL895-222K-RC	2200	$\pm 10\%$	45	1.0 KHz	252 KHz	0.80	4.21	190
RL895-272K-RC	2700	$\pm 10\%$	45	1.0 KHz	252 KHz	0.78	4.94	170
RL895-332K-RC	3300	$\pm 10\%$	45	1.0 KHz	252 KHz	0.70	6.16	150
RL895-392K-RC	3900	$\pm 10\%$	45	1.0 KHz	252 KHz	0.65	6.84	140
RL895-472K-RC	4700	$\pm 10\%$	45	1.0 KHz	252 KHz	0.60	7.89	130
RL895-562K-RC	5600	$\pm 10\%$	50	1.0 KHz	252 KHz	0.55	11.5	120
RL895-682K-RC	6800	$\pm 10\%$	50	1.0 KHz	252 KHz	0.48	13.2	110
RL895-822K-RC	8200	$\pm 10\%$	50	1.0 KHz	252 KHz	0.45	15.3	100
RL895-103K-RC	10,000	$\pm 10\%$	80	1.0 KHz	79.6 KHz	0.40	22.0	89
RL895-123K-RC	12,000	$\pm 10\%$	80	1.0 KHz	79.6 KHz	0.39	25.0	73
RL895-153K-RC	15,000	$\pm 10\%$	80	1.0 KHz	79.6 KHz	0.33	29.1	68
RL895-183K-RC	18,000	$\pm 10\%$	80	1.0 KHz	79.6 KHz	0.29	38.9	66
RL895-223K-RC	22,000	$\pm 10\%$	70	1.0 KHz	79.6 KHz	0.27	44.9	59
RL895-273K-RC	27,000	$\pm 10\%$	70	1.0 KHz	79.6 KHz	0.24	55.2	52
RL895-333K-RC	33,000	$\pm 10\%$	70	1.0 KHz	79.6 KHz	0.21	64.2	48
RL895-393K-RC	39,000	$\pm 10\%$	60	1.0 KHz	79.6 KHz	0.20	74.2	42
RL895-473K-RC	47,000	$\pm 10\%$	60	1.0 KHz	79.6 KHz	0.17	96.4	38

Electrical Schematic



General Specifications

Rated Current..... Inductance drop 10 %,
 Operating Temperature
-30 °C to +100 °C
 Storage Temperature
-30 °C to +100 °C

Materials

Core Material..... Ferrite
 Wire Enameled copper
 Terminal Coating..... Sn/Ag/Cu alloy

Marking

..... Value code on top of inductor

Packaging

Standard..... 100 pcs. per bag

Product Dimensions

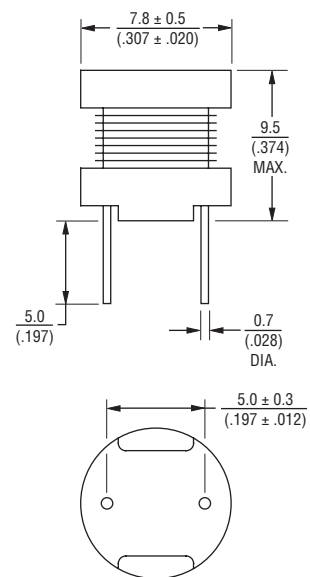

DIMENSIONS: $\frac{\text{MM}}{\text{(INCHES)}}$

How To Order

RL895 - 102K - RC

Model _____
 Value/Tolerance Code (see table) _____
 Compliance Code _____
 RC = RoHS Compliant

Example:
 RL895-102K-RC = 1000 μ H, $\pm 10\%$

REV. 02/11

*RoHS Directive 2002/95/EC Jan. 27, 2003 including annex and RoHS Recast 2011/65/EU June 8, 2011.
 Specifications are subject to change without notice.
 Customers should verify actual device performance in their specific applications