



## Quartz Crystal Specification

IQD Part No. + Packaging: LFX TAL025159Reel

Würth Part No. 830025159



### Description

- 2 x 6mm watch crystal with pre-formed legs to make a SMD package.
- Model CFPX-56
- Model Issue number 6

### Frequency Parameters

- Frequency 32.7680kHz
- Frequency Tolerance  $\pm 20.00$ ppm
- Tolerance Condition @ 25°C
- Overtone Order Fundamental
- Ageing  $\pm 5$ ppm max in 1st year

### Electrical Parameters

- Load Capacitance (CL) 12.50pF
- Shunt Capacitance (C0) 1.6pF typical
- Drive Level 1.0 $\mu$ W max
- ESR 40.00k $\Omega$  max
- Motional Capacitance (C1): 3.2fF typ
- Frequency Stability Coefficient:  $-0.034$ ppm/ $^{\circ}$ C<sup>2</sup>  $\pm 0.006$ ppm/ $^{\circ}$ C<sup>2</sup>

### Environmental Parameters

- Storage Temperature Range: -40 to 85°C
- High Temperature Storage: 85°C for 24hrs.
- Drop: 75cm drop (3 times) onto hard wooden board.

### Manufacturing Details

- Suitable for reflow soldering at 245°C max for 10sec max x 1 cycle.
- Note: Do not solder the body of the device to any PCB pads. Use other bonding methods such as adhesive, sealant, sticky-pads.
- RoHS Terminations SnAgCu
- RoHS Reflow Temp 245°C for 10secs max

### Compliance

- RoHS Status (2015/863/EU) Compliant
- REACH Status Compliant
- MSL Rating (JDEC-STD-033): Not Applicable

### Packaging Details

- Pack Style: Reel Tape & reel in accordance with EIA-481-D  
Pack Size: 3,000
- Alternative packing option available

## USEFUL LINKS

#### Toolbox:

[www.we-online.com/toolbox](http://www.we-online.com/toolbox)

#### Product Catalog:

[www.we-online.com/products](http://www.we-online.com/products)



### Outline (mm)

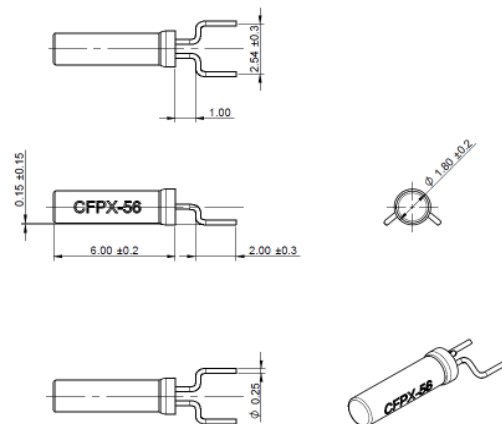

### Recommended Solder Pad Layout

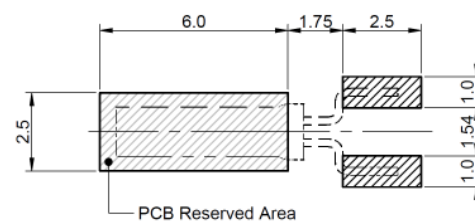

NOTE: Do not solder the body of this device to any PCB pads. Use other bonding methods such as adhesive sealant, sticky pads.

### CONTACT INFORMATION:

Würth Elektronik eiSos GmbH & Co. KG  
Max-Eyth-Str. 1, 74638 Waldenburg, Germany  
Tel: +49(0) 7942 945-0

Email: [eiSos@we-online.de](mailto:eiSos@we-online.de)  
Web: [www.we-online.com](http://www.we-online.com)



## Quartz Crystal Specification

*IQD Part No. + Packaging: LFX TAL025159Reel*

*Würth Part No. 830025159*



### Typical Frequency Stability Characteristics

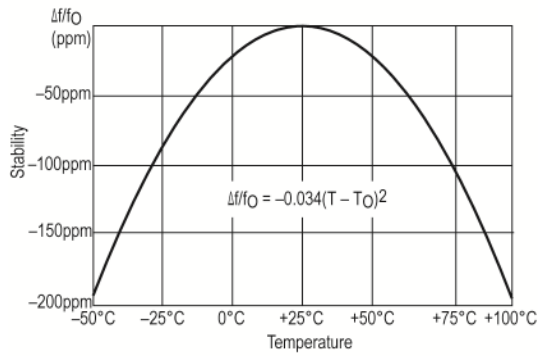

### Reflow Temperature Profile

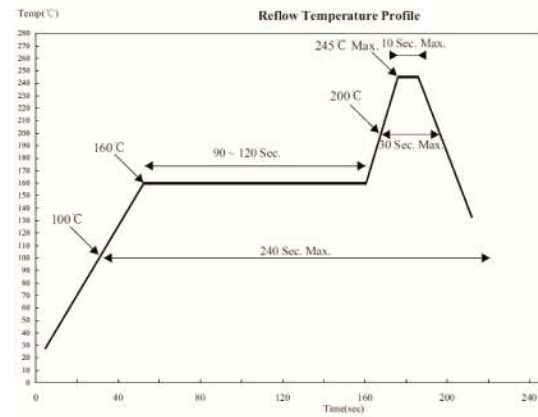

#### CONTACT INFORMATION:

Würth Elektronik eiSos GmbH & Co. KG  
 Max-Eyth-Str. 1, 74638 Waldenburg, Germany  
 Tel: +49(0) 7942 945-0

Email: [eiSos@we-online.de](mailto:eiSos@we-online.de)  
 Web: [www.we-online.com](http://www.we-online.com)