

PART NUMBER	REVISION	DESCRIPTION	FEED TYPE
2151929-1	G	FINE CRIMP HEIGHT ADJUST	MECHANICAL
2151929-2	G	FINE CRIMP HEIGHT ADJUST	PNEUMATIC
7-2151929-1	G	MECHANICAL AND CRIMP TOOLING KIT	MECHANICAL
7-2151929-2	G	PNEUMATIC AND CRIMP TOOLING KIT	PNEUMATIC
7-2151929-7	A	CRIMP TOOLING KIT	-

ATLANTIC VERSION TERMINATOR INTERFACE ADAPTER



APPLICATOR DATA		
CRIMP	SIZE	TYPE
WIRE	1.40 mm [.055]	F
INSUL	1.60 mm [.063]	F

APPLICATOR INSTRUCTIONS 408-35042

TERMINAL DATA: MOLEX TERMINAL MOLEX CRIMP SPECIFICATION	
TERMINAL NAME: MICRO-FIT (3.0) FEMALE CRIMP TERMINAL	
WIRE STRIP LENGTH 2.54-2.92 mm [.100-.115 IN]	INSULATION DIAMETER RANGE Ø1.10-1.30 mm [.043-.051 IN]
TERMINAL APPLICATION SPECIFICATION 63901-8800 Rev C	

TERMINAL DATA: ANDERSON TERMINAL MOLEX CRIMP SPECIFICATION	
TERMINAL NAME: MICRO-FIT (3.0) FEMALE CRIMP TERMINAL	
WIRE STRIP LENGTH 2.54-2.92 mm [.100-.115 IN]	INSULATION DIAMETER RANGE Ø1.10-1.30 mm [.043-.051 IN]
TERMINAL APPLICATION SPECIFICATION 63901-8800 Rev C	

TERMINALS APPLIED			
TE TERMINAL	MOLEX TERMINAL	TE TERMINAL	MOLEX TERMINAL
286747-1	43030-0003	286974-2	43031-0002
286747-2	43030-0002	286974-3	43031-0003
286747-3	43030-0001	286974-4	43031-0017
286747-4	43030-1001	286974-5	43031-0018
286747-5	43030-0051	286974-6	43031-0051
286747-6	43030-0052	286974-7	43031-0052
286747-7	43030-0053	286974-8	43031-0053
286747-8	45773-0001	286974-9	43031-0102
286747-9	45773-0002	1-286974-0	43031-0103
1-286747-0	45773-0003	1572840-1	44372-0002
1-286747-1	45773-0053	1572840-2	44372-3606
286974-1	43031-0001		

TERMINALS APPLIED			
TE TERMINAL	ANDERSON TERMINAL	TE TERMINAL	ANDERSON TERMINAL
1-286747-2	4202G1	1-286974-1	4203G1
1-286747-3	4202G3	1-286974-2	4203G3

WIRE SIZE	CRIMP HEIGHT mm [INCH]	CRIMP HEIGHT REFERENCE SETTING
20 AWG OR 0.50mm2	0.95 +/- 0.04 [.0375 +/- .0015]	8.3
22 AWG OR 0.35mm2	0.875 +/- 0.035 [.0345 +/- .0015]	9.1
24 AWG OR 0.20mm2	0.815 +/- 0.025 [.032 +/- .001]	9.8

- 1. RECOMMENDED SPARE PARTS
- 2. REFER TO SUPPLIED INSTRUCTION SHEET FOR CLEANING, LUBRICATION AND STORAGE OF APPLICATOR.
- 3. APPLY PART NUMBER 2-23419-6 LOCTITE TO THREADS OF ITEM 242.
- 4. CRIMP HEIGHT REFERENCE SETTING WAS THE SETTING USED WHEN THE APPLICATOR WAS QUALIFIED AT THE FACTORY. ADJUSTMENT MAY BE NECESSARY WHEN RUNNING APPLICATOR IN THE FIELD.
- 5. THIS APPLICATOR IS FOR INSULATION RANGE 1.10-1.30. REFER TO APPLICATOR 2151941 FOR INSULATION RANGE 2.31-2.77. REFER TO APPLICATOR 2151375 FOR INSULATION RANGE 1.30-1.85.
- 6. UNLESS SPECIFIED OTHERWISE TORQUE VALUES SHALL BE USED PER DOCUMENT, 101-35000.

***WARNING**
ON INSTALLATION, SET WIRE DISC TO CRIMP HEIGHT REFERENCE SETTING FOR LARGEST WIRE SIZE. CRIMP HEIGHT REFERENCE SETTINGS GREATER THAN THE VALUE SHOWN MAY CAUSE DAMAGE TO THE CRIMP TOOLING. REFER TO THE INSTRUCTION SHEET FOR PROPER SETUP AND ADJUSTMENTS.

ATLANTIC VERSION
Shown on sheets 1 of 4 & 2 of 4
(Pacific version shown on sheets 3 of 4 & 4 of 4)

LOC	DIST	REVISIONS					
A	66	P	LTN	DESCRIPTION	DATE	OWN	APVD
		D		ECR-19-016470	22OCT2019	TB	TE
		E		ECR-20-016023	10NOV2020	JWC	RR
		F		ECR-20-017418	14DEC2020	JWC	TE
		G		ECR-22-132472	14MAR2022	ROY	GEB

-	1	-	1	-	2119641-1	FEED CAM, AIR FEED	248
-	1	1	1	1	2119082-5	CAM, SNAIL, INSULATION ADJUSTMENT	244
-	1	1	1	1	2079764-1	WASHER, WAVE SPRING, CREST-TO-CREST	243
-	1	1	1	1	2119083-1	RETAINER, INSULATION DIAL	242
-	1	1	1	1	7-18023-7	SCR, SKT HD CAP M3 X 4.0	241
-	-	1	-	1	2119580-1	MECHANICAL FEED ASSEMBLY	239
-	1	-	1	-	2844940-1	AIR FEED MODULE	238
-	REF	REF	REF	REF	994970-2	COUNTER, MAGNETIC	164
-	1	1	1	1	1-18028-2	WASHER, FLAT, REG M4	119
-	1	1	1	1	2844908-1	SCREW, LOCKING	99
-	1	1	1	1	2844907-1	POST, LOCKING	98
-	1	1	1	1	455888-6	SPACER, CRIMPER	82
-	1	1	1	1	1803607-3	DOCUMENTATION PACKAGE	71
-	1	1	1	1	2119791-9	DEPRESSOR, WIRE	70
-	1	1	1	1	2119740-1	TAG IDENTIFICATION	67
-	2	2	2	2	2168078-1	SCREW, DRIVE, RH, RoHS, 2 x .188	66
-	1	1	1	1	2168083-2	SCR, SKT HD CAP, RoHS, M4 X 8.0	60
-	1	1	1	1	5-18022-5	SCR, HEX HD CAP, M4 X 6.0	59
-	1	1	1	1	1338685-1	PAWL, FEED	56
-	4	4	4	4	2168083-3	SCR, SKT HD CAP, RoHS, M4 X 12.0	54
-	2	2	2	2	2168083-3	SCR, SKT HD CAP, RoHS, M4 X 12.0	53
-	1	1	1	1	5018030-1	NUT, HEX, REG, RoHS, M3	52
-	1	1	1	1	811242-5	BUMPER, HOLD DOWN	51
-	1	1	1	1	690753-2	SPACER, TONKER	50
-	1	2	1	2	18023-9	SCR, SKT HD CAP M4 X 6.0	49
-	-	1	-	1	2119652-1	FEED CAM, PRE FEED	48
-	-	1	-	1	2119653-1	FEED CAM, POST FEED	47
-	1	1	1	1	1803583-9	APPLICATOR BASIC ASSEMBLY, SF	46
-	1	1	1	1	1803515-1	RAM ASSEMBLY, SF ATLANTIC	44
-	1	1	1	1	1803602-1	SCR, BHSC, RoHS (M8 X 25)	41
-	1	1	1	1	1752356-3	SUPPORT, TERMINAL	34
-	2	2	2	2	2079383-5	SCR, BHSC, RoHS (M4 X 20)	33
-	2	2	2	2	2-2844962-4	SPACER, CYLINDRICAL, STRIP GUIDE	30
-	1	1	1	1	2844992-1	ASSEMBLY, STRIP GUIDE	29
-	1	1	1	1	455888-3	SPACER, CRIMPER	28
-	1	1	1	1	1320928-2	STRIP GUIDE	24
-	1	1	1	1	2168083-2	SCR, SKT HD CAP, RoHS, M4 X 8.0	21
-	1	1	1	1	1-18028-2	WASHER, FLAT, REG M4	20
-	1	1	1	1	2119533-1	STRIPPER, SIDE FEED	19
-	1	1	1	1	2119806-1	INSERT, SHEAR	13
-	1	1	1	1	3-22280-3	SPRING, COMPRESSION	12
-	1	1	1	1	1-356885-4	STOP, SHEAR	11
-	1	1	1	1	2119805-1	SHEAR HOLDER, FRONT	10
-	1	1	1	1	1803095-6	FLOATING SHEAR, FRONT	9
-	1	2	2	1	1-1633917-6	ANVIL, COMBINATION	8
-	1	1	1	1	3-240641-9	SPACER	7
-	-	-	-	-	-	-	6
-	1	1	1	1	2119757-8	DEPRESSOR, SHEAR	5
-	1	1	1	1	5-238011-3	BLOCK, CRIMPER SPACER	4
-	1	2	2	1	7-2119582-6	CRIMPER, INSULATION F PREMIUM	3
-	1	1	1	1	455888-3	SPACER, CRIMPER	2
-	1	2	2	1	1-456402-5	CRIMPER, WIRE PREMIUM	1

DIMENSIONS:		TOLERANCES UNLESS OTHERWISE SPECIFIED:		MATERIAL:		FINISH:	
mm	0 PLC ±	1 PLC ±	2 PLC ±	3 PLC ±	4 PLC ±	ANGLES ±	FINISH ±

OWN	HOFFNER	19APR2013	
CHK	T. ELBIN	22APR2013	
APVD	T. ELBIN	22APR2013	
PRODUCT SPEC			
APPLICATION SPEC			
SIZE	A1	CAGE CODE	00779
DRAWING NO	C=2151929		
RESTRICTED TO			
WEIGHT			
Customer Accessible Production Drawing		SCALE	1:2
SHEET		1	OF 4
REV		G	

LOC	DIST	REV	DATE	BY	APPV
A	66				

FEED TYPE MECHANICAL

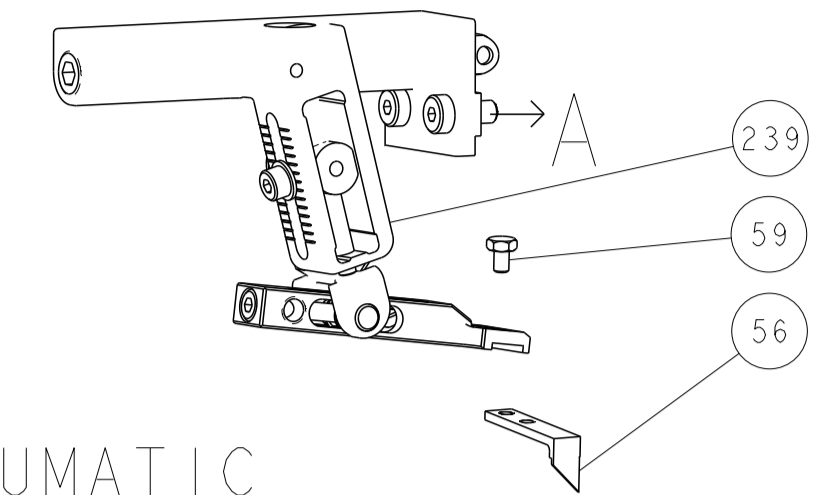

PNEUMATIC

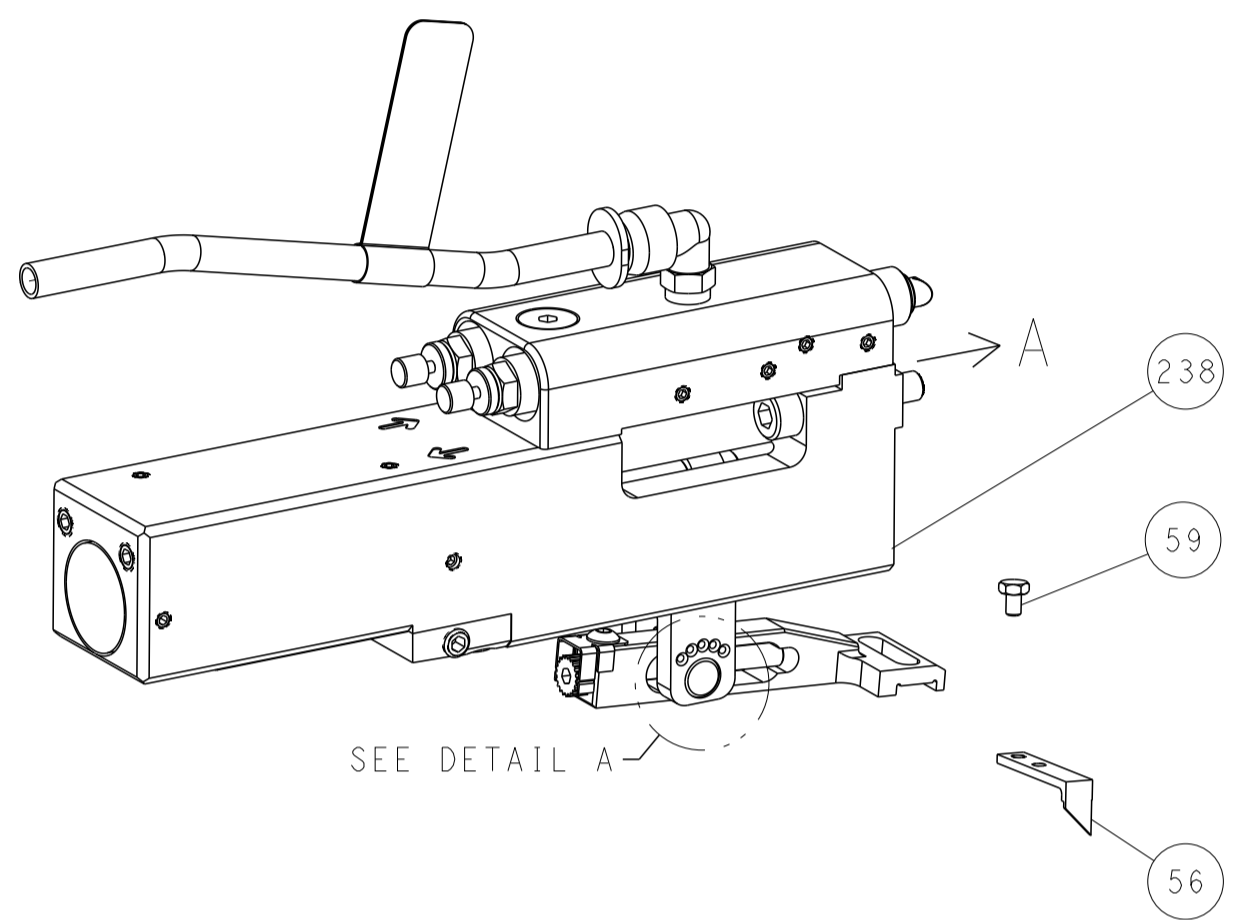

FEED SPRING SETTING POSITION (SHOWN FROM REAR SIDE)



DETAIL A

CAM POSITIONS

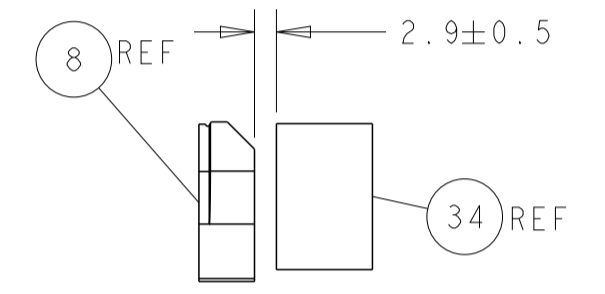
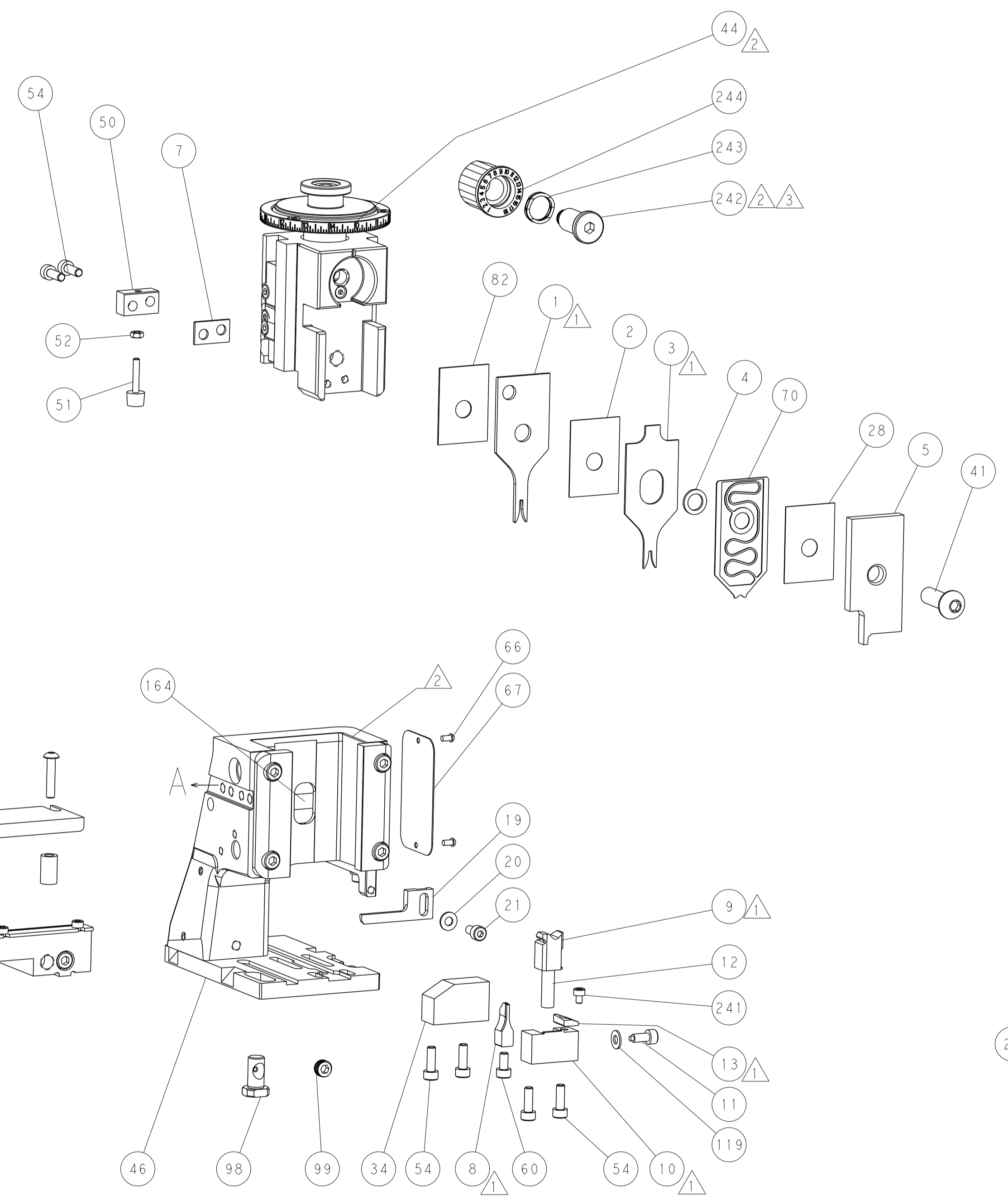
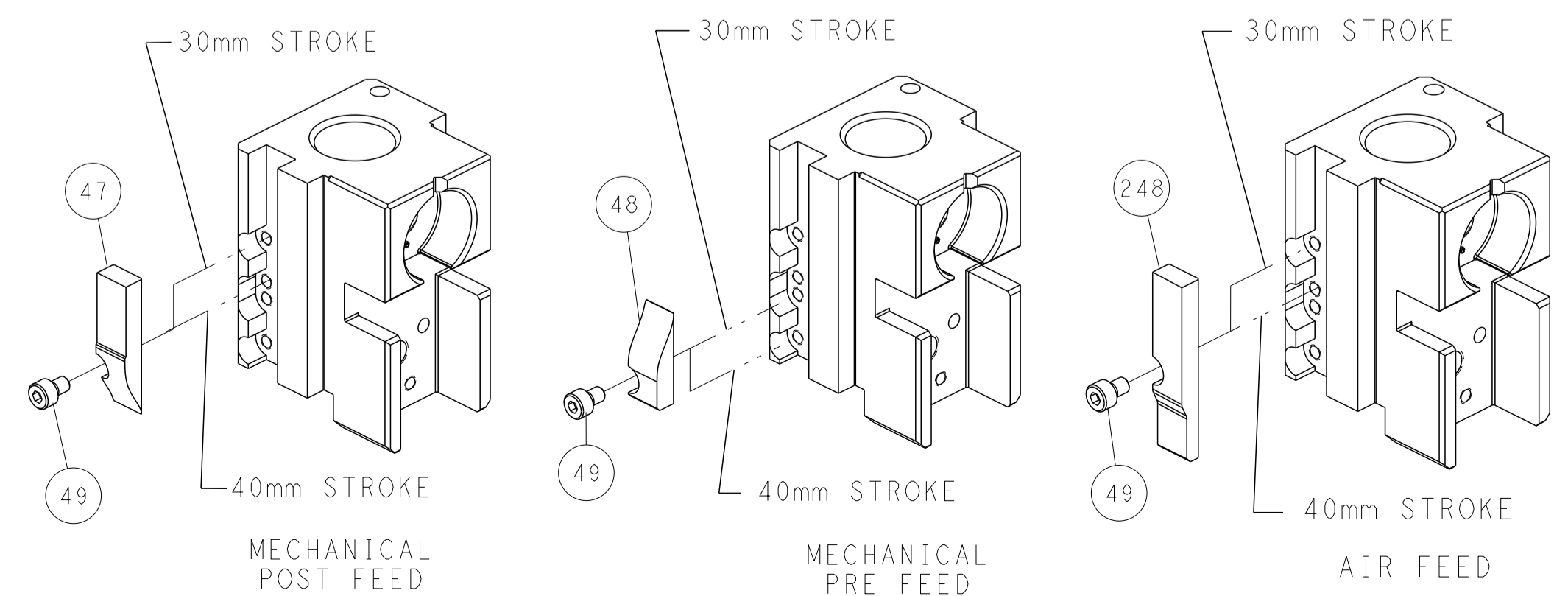

TERMINAL SUPPORT LOCATION

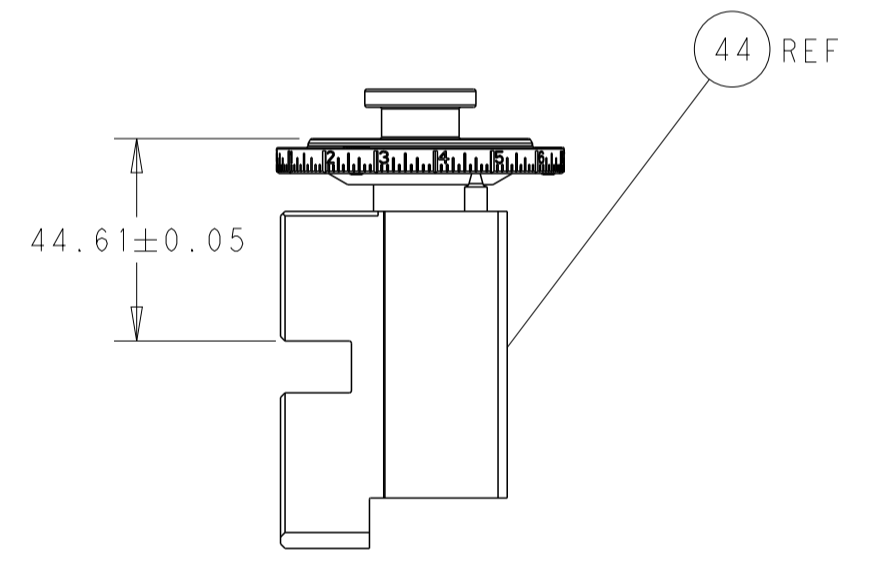

RAM SET-UP

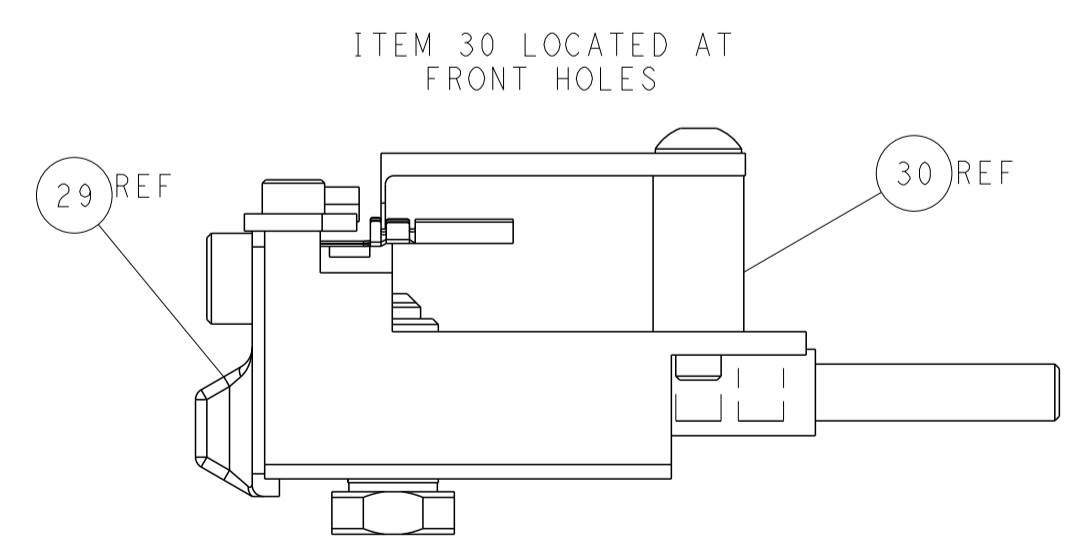

FEED TRACK POSITION GUIDE BY INSULATION BARREL

ATLANTIC VERSION
 Shown on sheets 1 of 4 & 2 of 4
 (Pacific version shown on sheets 3 of 4 & 4 of 4)

<small>THIS DRAWING IS UNPUBLISHED. RELEASED FOR PUBLICATION BY TYCO ELECTRONICS CORPORATION. ALL RIGHTS RESERVED.</small>		DWN: HOFFNER 19APR2013 CHK: T. ELBIN 22APR2013 APVD: T. ELBIN 22APR2013	NAME: TE Connectivity Harrisburg, PA 17105-3608
DIMENSIONS: mm TOLERANCES UNLESS OTHERWISE SPECIFIED: 0 PLC ± 1 PLC ± 2 PLC ± 3 PLC ± 4 PLC ± ANGLES ±	MATERIAL:	PRODUCT SPEC: APPLICATION SPEC: WEIGHT:	SIZE: A1 CAGE CODE: 00779 DRAWING NO: C=2151929 RESTRICTED TO:
Customer Accessible Production Drawing		SCALE: 1:2	SHEET: 2 OF 4 REV: G

PART NUMBER	REVISION	DESCRIPTION	FEED TYPE
2-2151929-1	G	FINE CRIMP HEIGHT ADJUST	MECHANICAL
2-2151929-2	G	FINE CRIMP HEIGHT ADJUST	PNEUMATIC
7-2151929-7	A	CRIMP TOOLING KIT	-

PACIFIC VERSION TERMINATOR
 INTERFACE ADAPTER



APPLICATOR DATA		
CRIMP	SIZE	TYPE
WIRE	1.40 mm [.055]	F
INSUL	1.60 mm [.063]	F

APPLICATOR INSTRUCTIONS
 408-35042

TERMINAL DATA: MOLEX TERMINAL MOLEX CRIMP SPECIFICATION	
TERMINAL NAME: MICRO-FIT (3.0) FEMALE CRIMP TERMINAL	
WIRE STRIP LENGTH 2.54-2.92 mm [1.00-.115 IN]	INSULATION DIAMETER RANGE Ø1.10-1.30 mm [.043-.051 IN]
TERMINAL APPLICATION SPECIFICATION 63901-8800 Rev C	

TERMINALS APPLIED			
TE TERMINAL	MOLEX TERMINAL	TE TERMINAL	MOLEX TERMINAL
286747-1	43030-0003	286974-2	43031-0002
286747-2	43030-0002	286974-3	43031-0003
286747-3	43030-0001	286974-4	43031-0017
286747-4	43030-1001	286974-5	43031-0018
286747-5	43030-0051	286974-6	43031-0051
286747-6	43030-0052	286974-7	43031-0052
286747-7	43030-0053	286974-8	43031-0053
286747-8	45773-0001	286974-9	43031-0102
286747-9	45773-0002	1-286974-0	43031-0103
1-286747-0	45773-0003	1572840-1	44372-0002
1-286747-1	45773-0053	1572840-2	44372-3606
286974-1	43031-0001		

WIRE SIZE	CRIMP HEIGHT mm [INCH]	CRIMP HEIGHT REFERENCE SETTING
20 AWG OR 0.50mm2	0.95+/-0.04 [.0375+/- .0015]	8.3
22 AWG OR 0.35mm2	0.875+/-0.035 [.0345+/- .0015]	9.1
24 AWG OR 0.20mm2	0.815+/-0.025 [.032+/- .001]	9.8

- 1. RECOMMENDED SPARE PARTS
- 2. REFER TO SUPPLIED INSTRUCTION SHEET FOR CLEANING, LUBRICATION AND STORAGE OF APPLICATOR.
- 3. APPLY PART NUMBER 2-23419-6 LOCTITE TO THREADS OF ITEM 242.
- 4. CRIMP HEIGHT REFERENCE SETTING WAS THE SETTING USED WHEN THE APPLICATOR WAS QUALIFIED AT THE FACTORY. ADJUSTMENT MAY BE NECESSARY WHEN RUNNING APPLICATOR IN THE FIELD.
- 5. THIS APPLICATOR IS FOR INSULATION RANGE 1.10-1.30. REFER TO APPLICATOR 2151941 FOR INSULATION RANGE 2.31-2.77. REFER TO APPLICATOR 2151375 FOR INSULATION RANGE 1.30-1.85.
- 6. UNLESS SPECIFIED OTHERWISE TORQUE VALUES SHALL BE USED PER DOCUMENT, 101-35000.

TERMINAL DATA: ANDERSON TERMINAL MOLEX CRIMP SPECIFICATION	
TERMINAL NAME: MICRO-FIT (3.0) FEMALE CRIMP TERMINAL	
WIRE STRIP LENGTH 2.54-2.92 mm [1.00-.115 IN]	INSULATION DIAMETER RANGE Ø1.10-1.30 mm [.043-.051 IN]
TERMINAL APPLICATION SPECIFICATION 63901-8800 Rev C	

TERMINALS APPLIED			
TE TERMINAL	ANDERSON TERMINAL	TE TERMINAL	ANDERSON TERMINAL
1-286747-2	4202G1	1-286974-1	4203G1
1-286747-3	4202G3	1-286974-2	4203G3

***WARNING**
 ON INSTALLATION, SET WIRE DISC TO CRIMP HEIGHT REFERENCE SETTING FOR LARGEST WIRE SIZE. CRIMP HEIGHT REFERENCE SETTINGS GREATER THAN THE VALUE SHOWN MAY CAUSE DAMAGE TO THE CRIMP TOOLING, REFER TO THE INSTRUCTION SHEET FOR PROPER SETUP AND ADJUSTMENTS.

PACIFIC VERSION
 Shown on sheets 3 of 4 & 4 of 4
 (Atlantic version shown on sheets 1 of 4 & 2 of 4)

LOC	DIST	REVISIONS					
		P	LTN	DESCRIPTION	DATE	OWN	APVD
A	66	-	-	SEE SHEET 1	-	-	-

-	1	1	2119082-5	CAM, SNAIL, INSULATION ADJUSTMENT	244
-	1	1	2079764-1	WASHER, WAVE SPRING, CREST-TO-CREST	243
-	1	1	2119083-1	RETAINER, INSULATION DIAL	242
-	1	1	7-18023-7	SCR, SKT HD CAP M3 X 4.0	241
-	-	1	2119580-1	MECHANICAL FEED ASSEMBLY	239
-	1	-	2844940-1	AIR FEED MODULE	238
-	REF	REF	994970-2	COUNTER, MAGNETIC	164
-	1	-	2119641-2	FEED CAM, AIR FEED	151
-	1	1	2168083-8	SCR, SKT HD CAP, RoHS, M4 X 16	144
-	4	4	2168083-9	SCR, SKT HD CAP, RoHS, M4 X 20	143
-	-	1	2119653-2	FEED CAM, POST FEED	142
-	1	1	1-1803583-0	APPLICATOR BASIC ASSEMBLY, SF	141
-	1	1	1803516-1	RAM ASSEMBLY, SF PACIFIC	140
-	1	1	1-18028-2	WASHER, FLAT, REG M4	119
-	1	1	2844908-1	SCREW, LOCKING	99
-	1	1	2844907-1	POST, LOCKING	98
-	1	1	455888-6	SPACER, CRIMPER	82
-	1	1	1803607-3	DOCUMENTATION PACKAGE	71
-	1	1	2119791-9	DEPRESSOR, WIRE	70
-	1	1	2119740-1	TAG IDENTIFICATION	67
-	2	2	2168078-1	SCREW, DRIVE, RH, RoHS, 2 x .188	66
-	1	1	5-18022-5	SCR, HEX HD CAP, M4 X 6.0	59
-	1	1	1338685-1	PAWL, FEED	56
-	2	2	2168083-3	SCR, SKT HD CAP, RoHS, M4 X 12.0	53
-	1	1	5018030-1	NUT, HEX, REG, RoHS, M3	52
-	1	1	811242-5	BUMPER, HOLD DOWN	51
-	1	1	690753-2	SPACER, TONKER	50
-	1	2	18023-9	SCR, SKT HD CAP M4 X 6.0	49
-	-	1	2119652-1	FEED CAM, PRE FEED	48
-	1	1	1803602-1	SCR, BHSC, RoHS (M8 X 25)	41
-	1	1	1752356-3	SUPPORT, TERMINAL	34
-	2	2	2079383-5	SCR, BHSC, RoHS (M4 X 20)	33
-	2	2	2-2844962-4	SPACER, CYLINDRICAL, STRIP GUIDE	30
-	1	1	2844992-1	ASSEMBLY, STRIP GUIDE	29
-	1	1	455888-3	SPACER, CRIMPER	28
-	1	1	1320928-2	STRIP GUIDE	24
-	1	1	2168083-2	SCR, SKT HD CAP, RoHS, M4 X 8.0	21
-	1	1	1-18028-2	WASHER, FLAT, REG M4	20
-	1	1	2119533-1	STRIPPER, SIDE FEED	19
-	1	1	2119806-1	INSERT, SHEAR	13
-	1	1	3-22280-3	SPRING, COMPRESSION	12
-	1	1	1-356885-4	STOP, SHEAR	11
-	1	1	2119805-1	SHEAR HOLDER, FRONT	10
-	1	1	1803095-6	FLOATING SHEAR, FRONT	9
-	1	1	1-1633917-6	ANVIL, COMBINATION	8
-	1	1	3-240641-9	SPACER	7
-	-	-	-	-	6
-	1	1	2119757-8	DEPRESSOR, SHEAR	5
-	1	1	5-238011-3	BLOCK, CRIMPER SPACER	4
-	1	1	7-2119582-6	CRIMPER, INSULATION F PREMIUM	3
-	1	1	455888-3	SPACER, CRIMPER	2
-	1	1	1-456402-5	CRIMPER, WIRE PREMIUM	1

DIMENSIONS:		TOLERANCES UNLESS OTHERWISE SPECIFIED:		MATERIAL:		FINISH:	
mm	0 PLC ±	1 PLC ±	2 PLC ±	3 PLC ±	4 PLC ±	ANGLES ±	FINISH ±

OWN	CHK	APVD	DATE	DESCRIPTION	ITEM NO
HOFFNER	ELBIN	ELBIN	22APR2013	22APR2013	19APR2013

SIZE	CAGE CODE	DRAWING NO	RESTRICTED TO
A1	00779	2151929	Customer Accessible Production Drawing

Customer Accessible Production Drawing SCALE 1:2 SHEET 3 OF 4 REV G

LOC	DIST	REVISIONS					
A	66	P	LTN	DESCRIPTION	DATE	DMN	APVD
		-		SEE SHEET 1			

FEED TYPE MECHANICAL

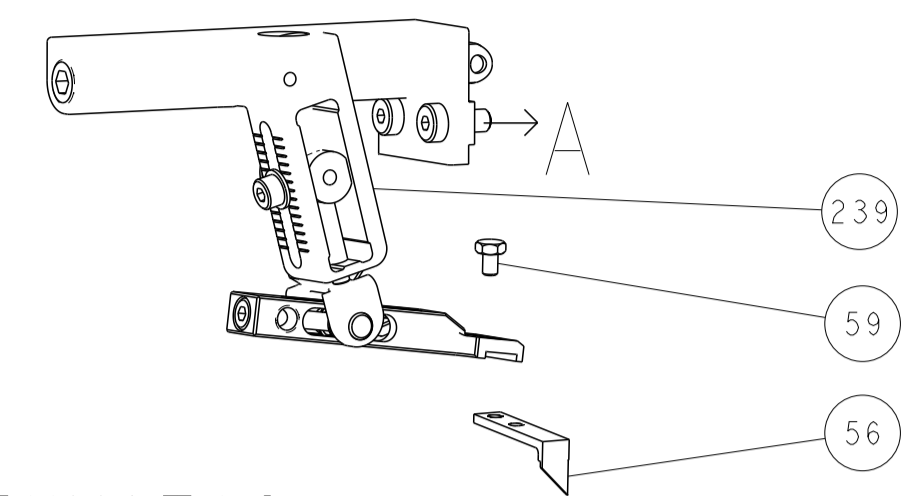

PNEUMATIC

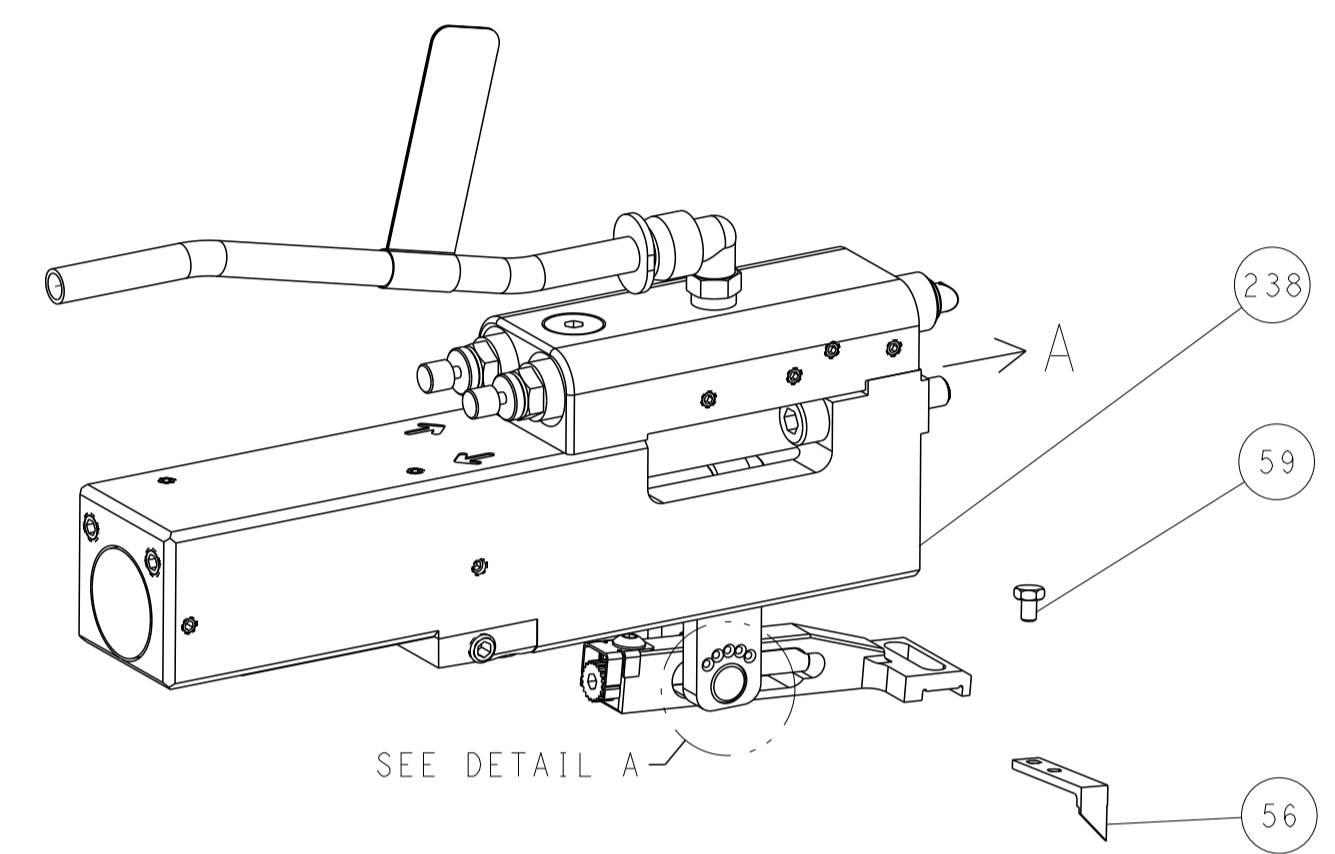

FEED SPRING SETTING POSITION (SHOWN FROM REAR SIDE)



DETAIL A

CAM POSITIONS

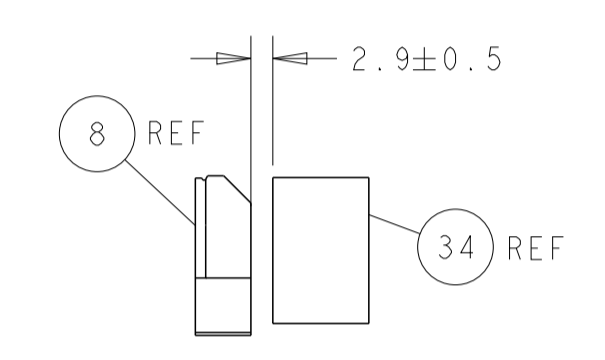
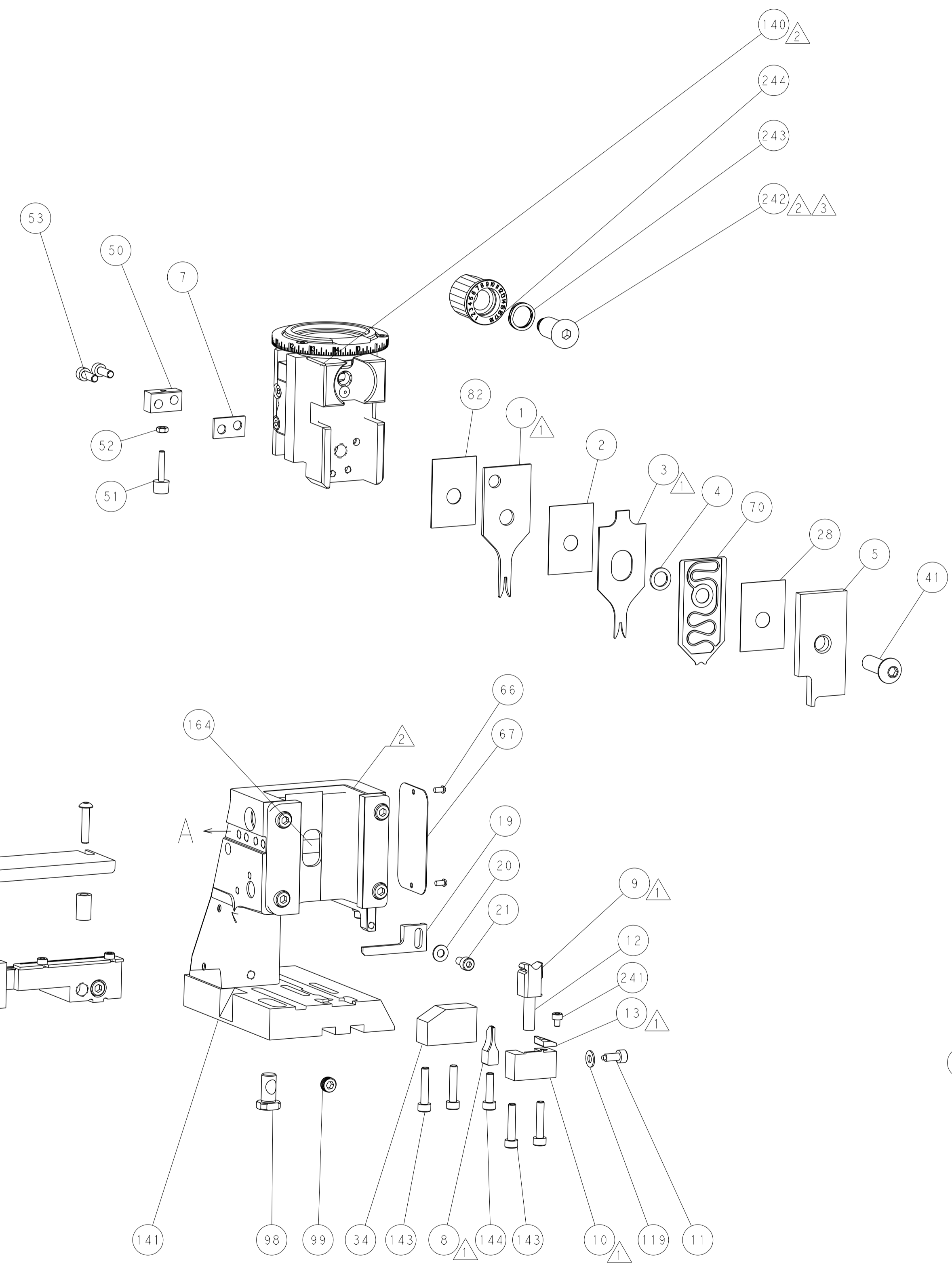
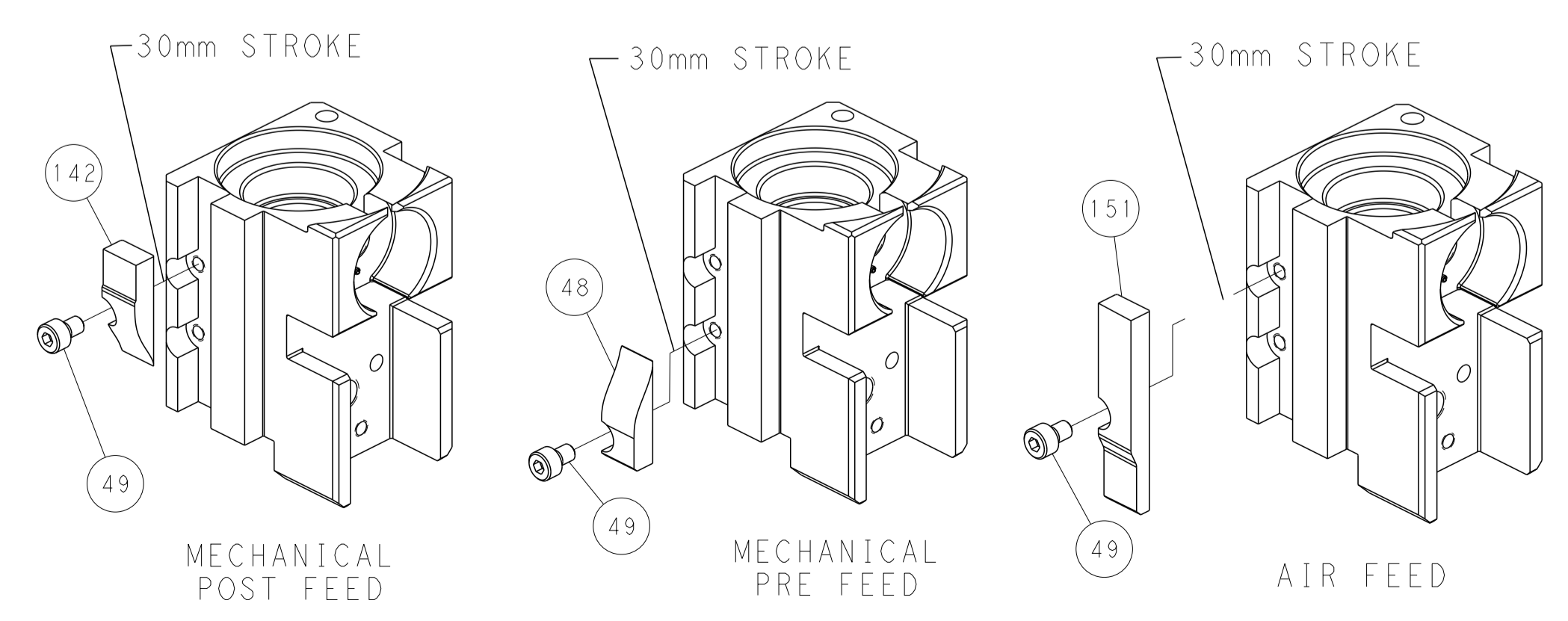

TERMINAL SUPPORT LOCATION

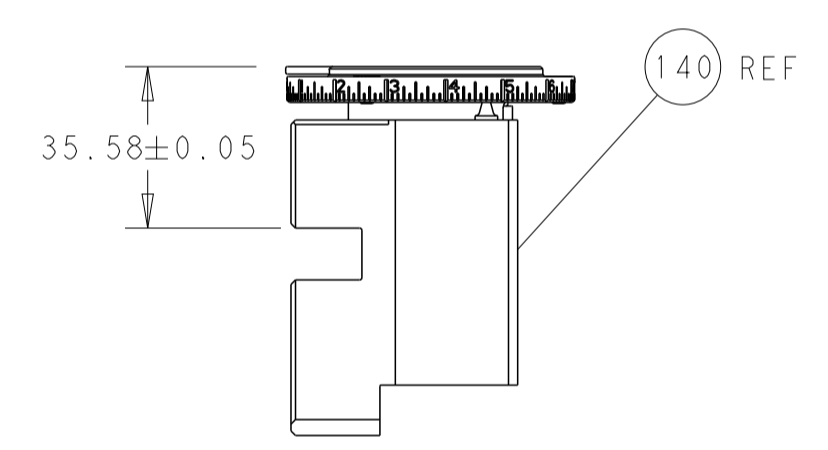

RAM SET-UP

ITEM 30 LOCATED AT
FRONT HOLES

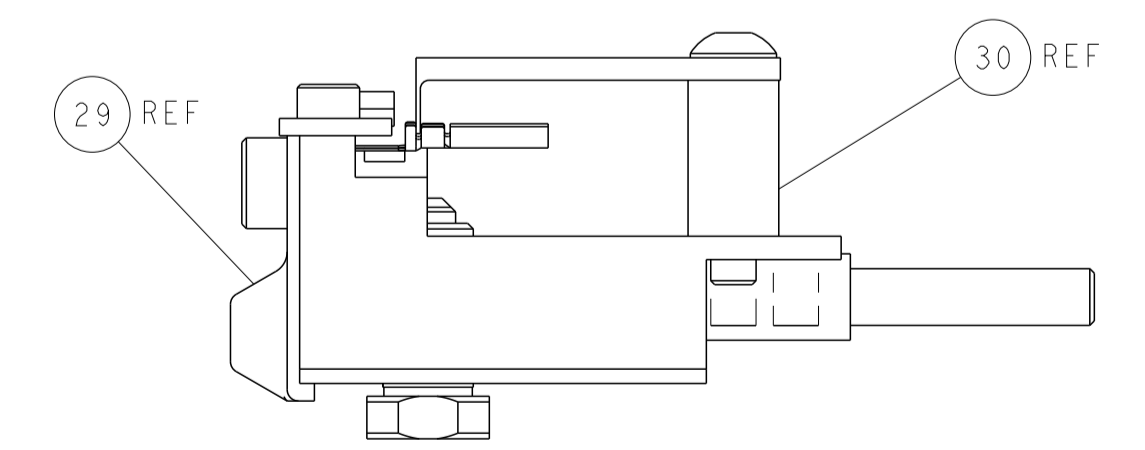

FEED TRACK POSITION
GUIDE BY INSULATION BARREL

PACIFIC VERSION
 Shown on sheets 3 of 4 & 4 of 4
 (Atlantic version shown on sheets 1 of 4 & 2 of 4)

<small>THIS DRAWING IS UNPUBLISHED. RELEASED FOR PUBLICATION. IT IS THE PROPERTY OF TYCO ELECTRONICS CORPORATION. IT IS TO BE USED ONLY FOR THE PURPOSES AND IN THE QUANTITIES SPECIFIED IN THE ORDER. IT IS TO BE RETURNED TO TYCO ELECTRONICS CORPORATION FOR REUSE OR DESTRUCTION AT THE END OF THE PROJECT.</small>		DWN: HOFFNER 19APR2013 CHK: T. ELBIN 22APR2013 APVD: T. ELBIN 22APR2013	TE Connectivity Harrisburg, PA 17105-3608
DIMENSIONS: mm 	TOLERANCES UNLESS OTHERWISE SPECIFIED: 0 PLC ± 1 PLC ± 2 PLC ± 3 PLC ± 4 PLC ± ANGLES ± FINISH	NAME: Ocean Side Feed Applicator APPLICATION SPEC:	SIZE: A1 CAGE CODE: 00779 DRAWING NO: C=2151929 RESTRICTED TO: G
MATERIAL:	WEIGHT:	Customer Accessible Production Drawing	SCALE: 1:2 SHEET 4 OF 4 REV G