

USER MANUAL

MODEL 2018 RS-232 to Current Loop Converter



Part# 07M2018-B
Doc# 07304UB
Revised 3/31/94

SALES OFFICE
(301) 975-1000
TECHNICAL SUPPORT
(301) 975-1007
<http://www.patton.com>

1.0 WARRANTY INFORMATION

Patton Electronics warrants all Model 2018 components to be free from defects, and will—at our option—repair or replace the product should it fail within one year from the first date of shipment.

This warranty is limited to defects in workmanship or materials, and does not cover customer damage, abuse or unauthorized modification. If this product fails or does not perform as warranted, your sole recourse shall be repair or replacement as described above. Under no condition shall **Patton Electronics** be liable for any damages incurred by the use of this product. These damages include, but are not limited to, the following: lost profits, lost savings and incidental or consequential damages arising from the use of or inability to use this product.

Patton Electronics specifically disclaims all other warranties, expressed or implied, and the installation or use of this product shall be deemed an acceptance of these terms by the user.

1.1 RADIO AND TV INTERFERENCE

The Model 2018 generates and uses radio frequency energy, and if not installed and used properly—that is, in strict accordance with the manufacturer's instructions—may cause interference to radio and television reception. The Model 2018 has been tested and found to comply with the limits for a Class A computing device in accordance with the specifications in Subpart J of Part 15 of FCC rules, which are designed to provide reasonable protection from such interference in a commercial installation. However, there is no guarantee that interference will not occur in a particular installation. If the Model 2018 does cause interference to radio or television reception, which can be determined by disconnecting the RS-232 interface, the user is encouraged to try to correct the interference by one or more of the following measures: moving the computing equipment away from the receiver, re-orienting the receiving antenna and/or plugging the receiving equipment into a different AC outlet (such that the computing equipment and receiver are on different branches).

1.2 SERVICE

All warranty and non-warranty repairs must be returned freight prepaid and insured to Patton Electronics. All returns must have a Return Materials Authorization number on the outside of the shipping container. This number may be obtained from Patton Electronics Technical Service at **(301) 975-1007**. *Packages received without an RMA number will not be accepted.*

Patton Electronics' technical staff is also available to answer any questions that might arise concerning the installation or use of your Model 2018. Technical Service hours: **8AM to 5PM EST, Monday through Friday.**

2.0 GENERAL INFORMATION

Thank you for your purchase of this Patton Electronics product. This product has been thoroughly inspected and tested and is warranted for One Year parts and labor.

If any questions or problems arise during installation or use of this product, please do not hesitate to contact Patton Electronics Technical Support at (301) 975-1007.

2.1 FEATURES

- Full duplex, asynchronous transmission over 4 wires
- Operates actively or passively
- Data rates from 50 to 115,200 bps
- Range to 5 miles on 24 AWG twisted pair
- No AC power required
- Optically isolated on line side
- DB-25 connectors on both ends
- External DCE/DTE switch
- Made in the USA

2.2 DESCRIPTION

The Model 2018 RS-232 to current loop converter lets an asynchronous RS-232 device communicate with a 20mA or 60mA current loop device. The Model 2018 requires no AC power or batteries to operate and supports data rates to 115.2 Kbps. When connected to an active current loop interface, no additional power is needed. When connected to a passive current loop interface, DC line power may be applied to the Model 2018 via pins 9 and 21 of the DB-25 current loop interface.

Operating full duplex, the Model 2018 supports communication distances up to 5 miles over two unconditioned twisted pair. To guard against data loss due to ground loops, the Model 2018 is equipped with 2500V RMS optical isolators on the line side.

The Patton Model 2018 connects directly to either the RS-232 interface or the 20mA or 60mA current loop interface using a male or female DB-25 connector. An external DCE/DTE switch on the Model 2018 eliminates the need for a crossover cable on the RS-232 interface. The Model 2018 is manufactured in the USA.

3.0 CONFIGURATION

The Model 2018 is designed to be easy to use. There are no internal jumpers or DIP switches to set, so there is no need to open the case to configure the unit. The only configuration necessary for operation is proper setting of the external DCE/DTE switch.

3.1 SETTING THE DCE/DTE SWITCH

For your convenience, the Model 2018 has an externally accessible DCE/DTE switch (see Figures 1 and 2). If the RS-232 device connected to the Model 2018 is a modem or multiplexer (or is wired like one), set the switch to "DTE". This setting causes the Model 2018 to behave like Data Terminal Equipment, transmitting data on RS-232 pin 2 and receiving data on pin 3.

If the RS-232 device connected to the Model 2018 is a PC, terminal or host computer (or is wired like one), set the switch to "DCE". This setting causes the Model 2018 to behave like Data Communications Equipment, transmitting data on RS-232 pin 3 and receiving data on pin 2. Remember: The switch setting is always from the point of view of the Model 2018, not the connected equipment.

3.1.1 DCE/DTE SWITCH POSITIONS

The unique characteristics of this product made it necessary to reverse the DCE/DTE switch positions on half of the models. Since the switch positions are clearly marked on the label of your Model 2018, you should have no trouble seeing which way to move the switch. But just to double-check, refer to Figures 1 and 2 and make sure the markings on your unit correspond to those below:



Figure 1. Switch positions for 2018MF and 2018FF

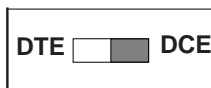

Figure 2. Switch positions for 2018FM and 2018MM

4.0 INSTALLATION

The versatile Model 2018 can be installed in at least three different applications: RS-232 to *active* current loop, RS-232 to *passive* current loop and RS-232 to RS-232 (distances to 5 miles over two twisted pair).

4.1 RS-232 TO ACTIVE CURRENT LOOP

The simplest installation of the Model 2018 is into environments where an RS-232 device is communicating with an *active* current loop device. In this case, both the RS-232 and current loop interfaces are automatically supplying power to the data circuit. As Figure 3 illustrates, only 4 wires are needed to connect the current loop side of the Model 2018 to the current loop device interface. For best results, these 4 wires should be in twisted pairs.

To install the Model 2018 in an active current loop environment, you will need a DB-25 cable with at least 4 conductors. These conductors should be wired to the appropriate DB-25 pins as shown in Figure 3. Since this end of the cable connects to the Model 2018, its gender should be *opposite* to that of the Model 2018's connector. When you connect this cable to your current loop device, be sure the signal paths correspond to those shown.

The RS-232 side of the Model 2018 is designed to plug directly into the serial port of your RS-232 device. You may use a straight through RS-232 cable for connection as well. Be sure to set the Model 2018's DCE/DTE switch according to the instructions in Section 3.0 of this manual.

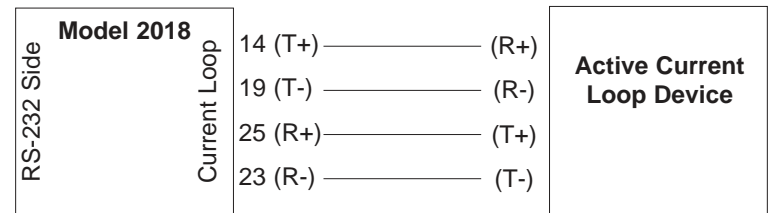

Figure 3. Connection to an active current loop interface

4.2 RS-232 TO PASSIVE CURRENT LOOP

You may install the Model 2018 into environments where an RS-232 device is communicating with a *passive* current loop device. In this case, you will need to supply external DC power* to the Model 2018 on the current loop interface side. Figure 4 shows the appropriate pins/voltages for applying external DC power to the Model 2018.

To install the Model 2018 in a passive current loop environment, you will need a DB-25 cable with at least 3 conductors plus shield. Wire the cable as shown in Figure 4, paying attention to jumpers and signal paths. Since this end of the cable connects to the Model 2018, its gender should be *opposite* to that of the Model 2018's connector. When you connect this cable to your current loop device, be sure the signal paths correspond to those shown.

The RS-232 side of the Model 2018 is designed to plug directly into the serial port of your RS-232 device. You may use a straight through RS-232 cable for connection as well. Be sure to set the Model 2018's DCE/DTE switch according to the instructions in Section 3.0 of this manual.

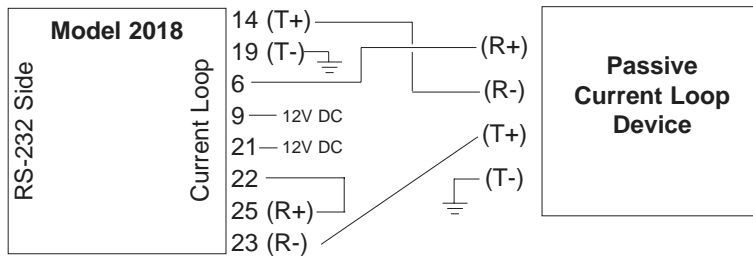

Figure 4. Connection to a passive current loop interface

*Note: A 12V DC power adapter is available from Patton Electronics

4.3 RS-232 TO RS-232 DISTANCE EXTENSION

You may use the Model 2018 as a distance extender for RS-232 to RS-232 applications. In this case, you will need *two* Model 2018 converters, plus an external DC power source* on one end of the communication link. Figure 5 shows the appropriate pin/voltage for applying external DC power to the Model 2018 link.

To use two Model 2018s as RS-232 distance extenders, you will need a DB-25 cable with at least two twisted pairs (19 - 26 AWG). Your cable should be custom-wired as shown in Figure 5. Be sure the genders of the cable's DB-25 connectors are *opposite* to those of the respective Model 2018s. The maximum cable length depends on various factors, including overall cable capacitance, data rate, noise and operating environment. Call Patton Technical Support at (301) 975-1007 if you have any questions.

The RS-232 side of the Model 2018 is designed to plug directly into the serial port of your RS-232 device. You may use a straight through RS-232 cable for connection as well. Be sure to set the Model 2018's DCE/DTE switch according to the instructions in Section 3.0 of this manual.

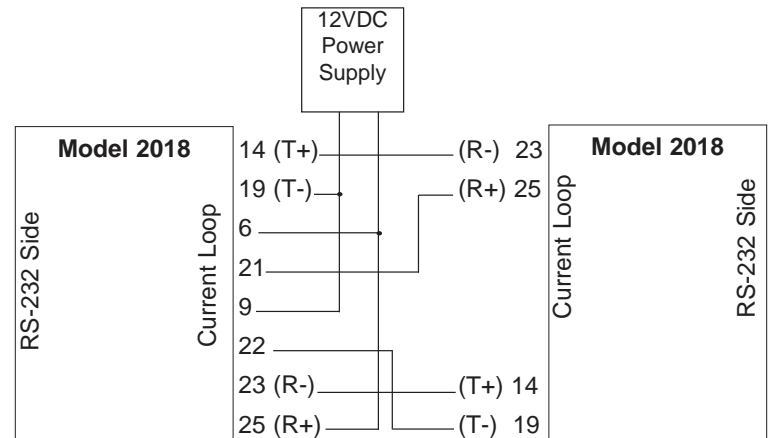

Figure 5. RS-232 distance extension

*Note: A 12V DC power adapter is available from Patton Electronics

APPENDIX A

PATTON MODEL SPECIFICATIONS

- Transmission Line:** 19 to 26 AWG twisted pair
- Range:** Up to 5 miles on 24 AWG twisted pair
- Interfaces:** Asynchronous, EIA RS-232, CCITT V.24 full duplex; 20mA or 60mA current loop
- Data Rates:** 50 - 115,200 bps
- Isolation:** 2500V RMS via opto-isolators on line side
- Connectors:** DB-25 male or female on both RS-232 and current loop sides
- Power Supply:** No external power; uses power from NIC data and control signals
- Temperature Range:** 0-60°C (32-140°F)
- Altitude:** 0-15,000 feet
- Humidity:** 5 to 95% noncondensing
- Dimensions:** 2.21"l x 0.8"h x 2.10"w
- Weight:** 1.7 oz

APPENDIX B
BLOCK DIAGRAM

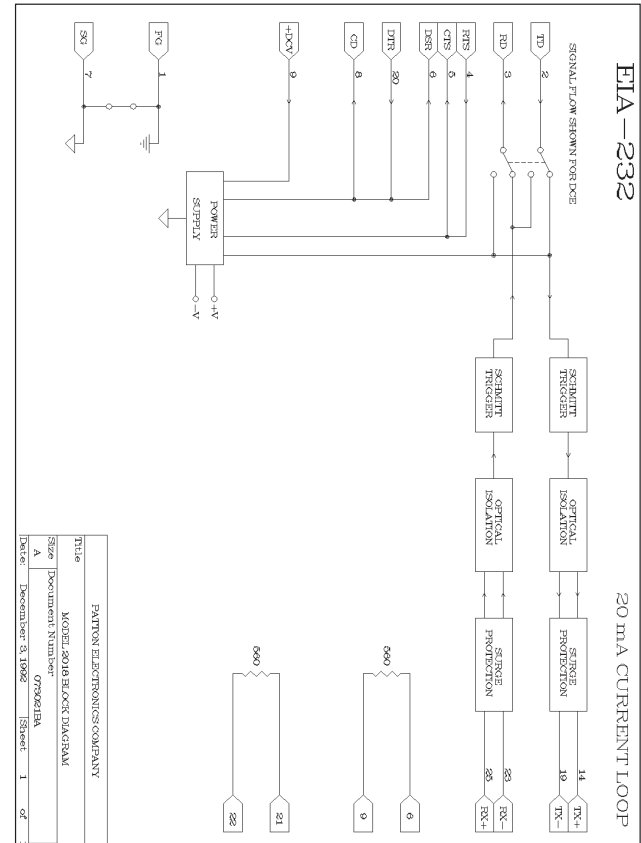

**APPENDIX C
RS-232 PIN CONNECTIONS**

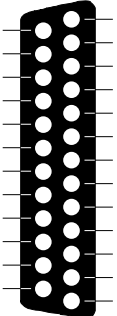
DIRECTION	"DCE" SETTING	DIRECTION
To Mdl 2018	 <p>1- (FG) Frame Ground 2- (TD) Transmit Data 3- (RD) Receive Data 4- (RTS) Request to Send 5- (CTS) Clear to Send 6- (DSR) Data Set Ready 7- (SG) Signal Ground 8- (DCD) Data Carrier Detect</p> <p>Data Term. Ready (DTR) - 20</p>	<p>To Mdl 2018 From Mdl 2018 To Mdl 2018 From Mdl 2018 From Mdl 2018 From Mdl 2018</p>

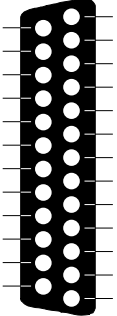
DIRECTION	"DTE" SETTING	DIRECTION
From Mdl 2018	 <p>1- (FG) Frame Ground 2- (TD) Transmit Data 3- (RD) Receive Data 4- (RTS) Request to Send 5- (CTS) Clear to Send 6- (DSR) Data Set Ready 7- (SG) Signal Ground 8- (DCD) Data Carrier Detect</p> <p>Data Term. Ready (DTR) - 20</p>	<p>From Mdl 2018 To Mdl 2018 From Mdl 2018 To Mdl 2018 To Mdl 2018 To Mdl 2018</p>

**APPENDIX D
CURRENT LOOP PIN CONNECTIONS**

