

---

**IRU3046 EVALUATION BOARD USER GUIDE****INTRODUCTION**

The IRU3046 IC combines a dual synchronous PWM controller and a linear regulator controller, providing a cost-effective, high performance and flexible solution for multi-output applications. The dual synchronous controller can be configured as 2-independent or 2-phase controller. In 2-phase configuration, the IRU3046 provides programmable current sharing which is ideal when the output power exceeds any single input power budget. IRU3046 provides a separate adjustable output by driving a switch as a linear regulator. The Eval Board is designed for current sharing mode (see the IRU3046 data sheet for detail description), the two PWM controllers provide one single output and the linear regulator provides the second output.

**SPECIFICATION DATA****Switcher:** $V_{IN1(MASTER)} = 5V$  $V_{IN2(SLAVE)} = 12V$  $V_{OUT} = 1.5V$  $I_{OUT} = 16A$  $\Delta V_{OUT} = 75mV$  $FS = 200KHz$ **Linear Regulator:** $LDO_{IN} = 3.3V$  $LDO_{OUT} = 2.5V$  $I_{OUT} = 2A$ 

---

**INPUT/OUTPUT CONNECTIONS**

The following is the input/output connections:

**Inputs:**

JP1: +5V and Gnd.

JP2: +12V and Gnd.

JP5: LDOIN (3.3V) and Gnd.

**Alternative connections:**

JP3: ATX Connector for 3.3V, 5V and 12V inputs and Gnd.

**Outputs:**

JP4: +VOUT (1.5V) and Gnd.

JP6: +LDOOUT (2.5V) and Gnd.

The connection points is shown in Figure 1. Connect the power supply cables according to this figure, minimize wire lengths to reduce losses in the wire. Test point J1, J2 and J3 provide easy connection for oscilloscope voltage probe to monitor the inductor points for each PWM section and output voltage.

**CONNECTION DIAGRAM**

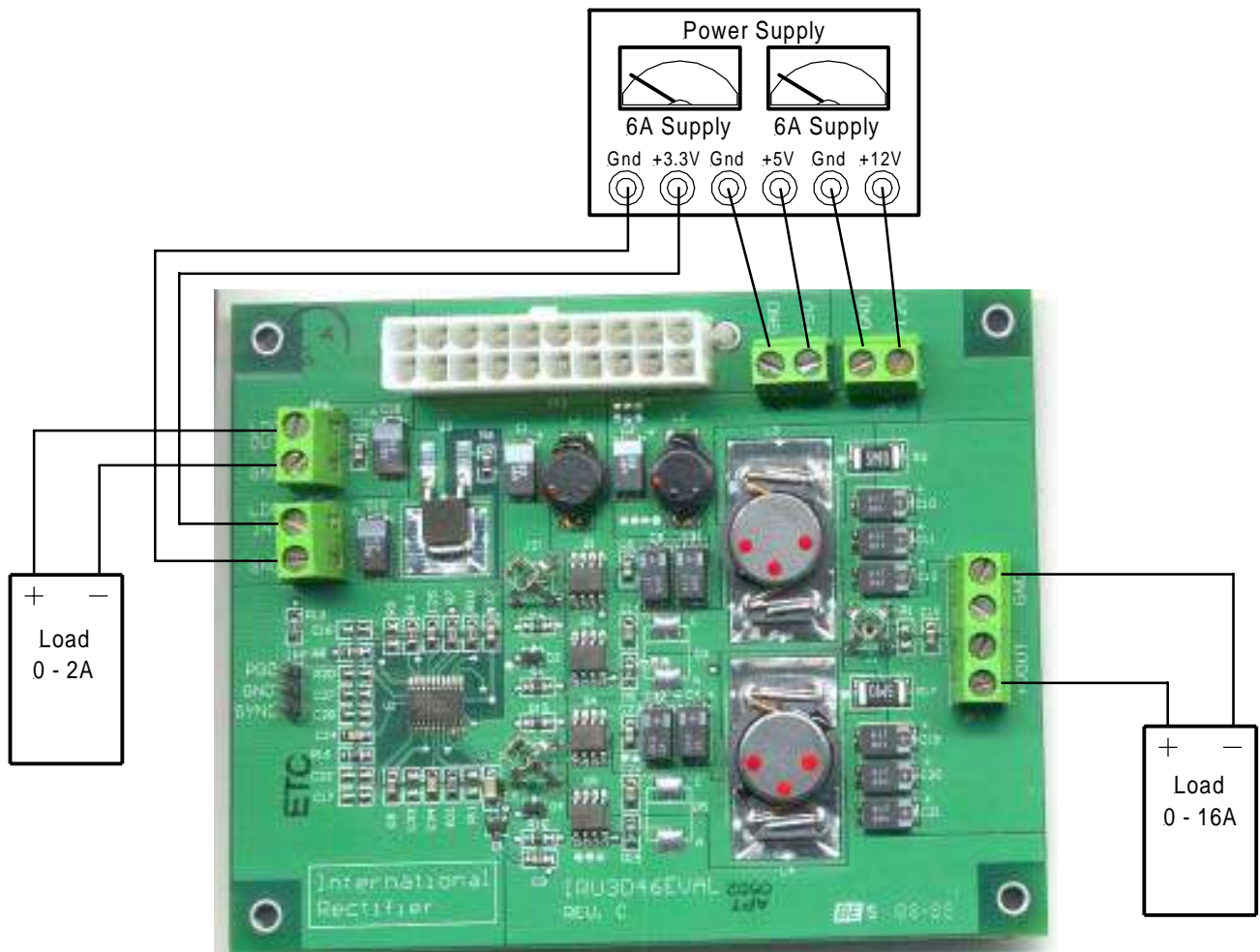

Figure 1 - Connection diagram of evaluation-board for IRU3046.

**LAYOUT**

The top side (component) layer for IRU3046 Eval board is shown in Figure 2. The input capacitors are all located close to the MOSFETs. All the decoupling capacitors, charge pump capacitor and feedback components are located close to IC. The two current sense resistor located close to inductors and they are located symmetri-

cal to the output. The feedback resistors are tied to the output voltage at the point of regulation.

The PCB is 4-layers board, one layer is dedicated to Power GND and the analog GND is kept separated from the PGND and it is connected at a single point.

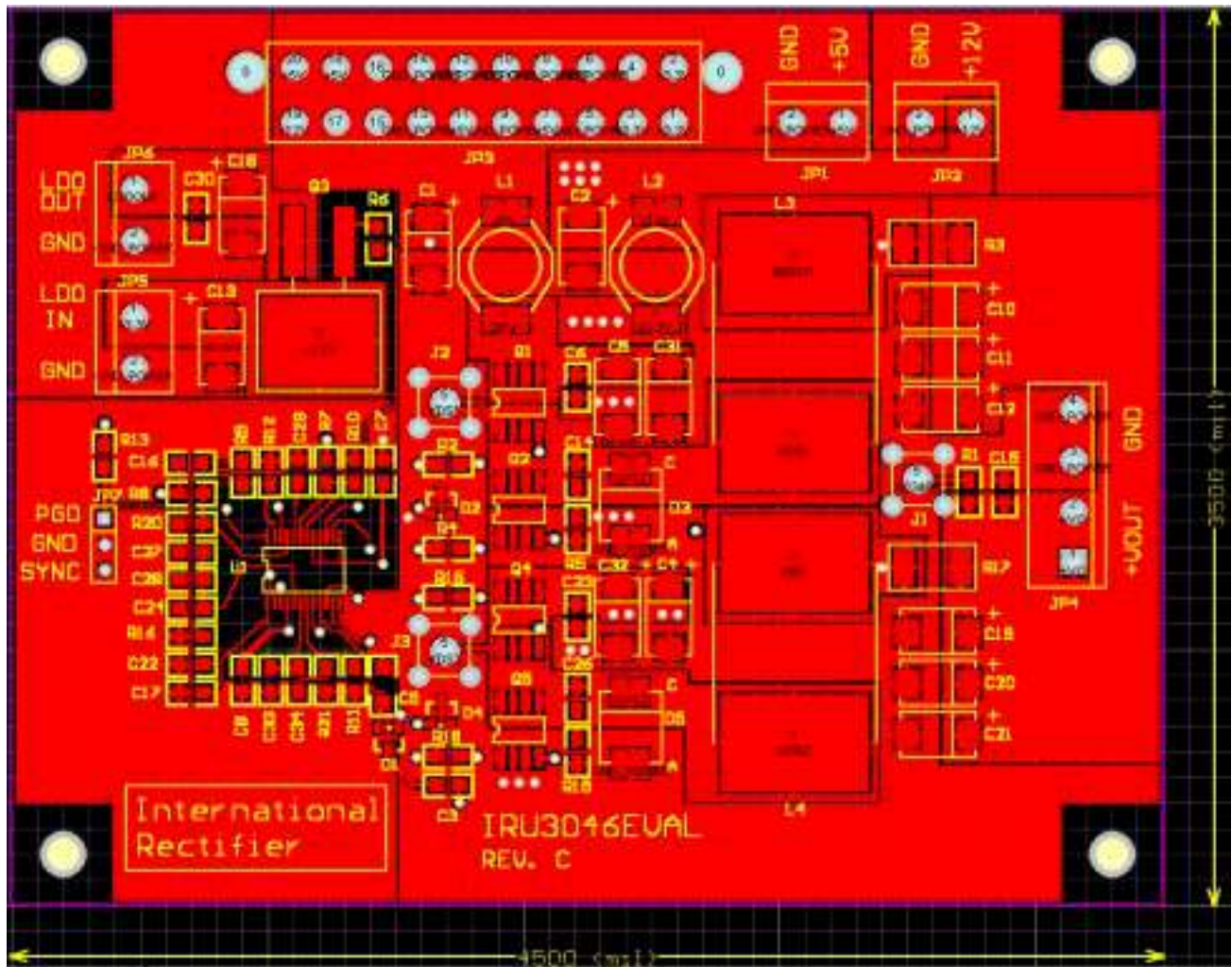
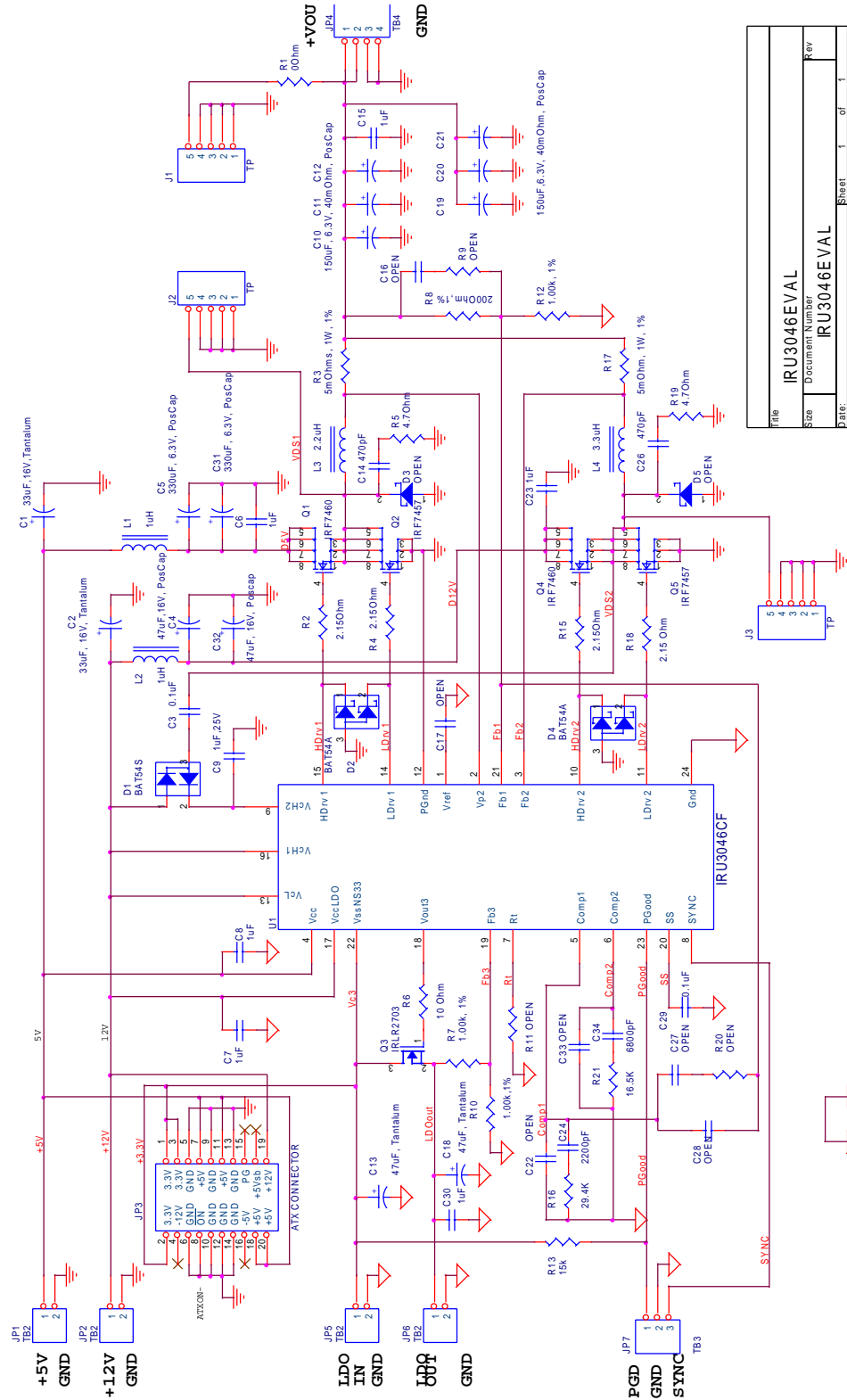

Figure 2 - Top layer of evaluation-board for IRU3046.

**SCHEMATIC**



File	IRU3046EVAL
Size	Document Number
Date	IRU3046EVAL
	Sheet 1 of 1

Figure 3 - Schematic of evaluation-board for IRU3046.

**BILL OF MATERIAL**

Ref Desig	Description	Value	Qty	Part#	Manuf	Web site (www.)
Q1,Q4	MOSFET	20V, 10mΩ, 12A	2	IRF7460	IR	irf.com
Q2,Q5	MOSFET	20V, 7mΩ, 15A	2	IRF7457	IR	
Q3	MOSFET	30V, 0.045Ω, 23A	1	IRLR2703	IR	
U1	Controller	Synchronous PWM	1	IRU3046	IR	
D1	Diode	Fast Switching	1	BAT54S	IR	
D2,D4	Diode *	Fast Switching	2	BAT54A or 1N4148	IR Any	
L1,L2	Inductor	1μH, 6.8A	2	D03316P-102	Coilcraft	coilcraft.com
L3	Inductor	2.2μH, 12A	1	D05022P-222HC	Coilcraft	
L4	Inductor	3.3μH, 10A	1	D05022P-332HC	Coilcraft	
C1,C2	Cap, Tantalum	33μF, 16V	2	ECS-T1CD336R	Panasonic	maco.panasonic.co.jp
C4,C32	Cap, Poscap	47μF, 16V	2	16TPB47M	Sanyo	sanyo.com/industrial
C5,C31	Cap, Poscap	330μF, 6.3V	2	6TPB330M	Sanyo	
C10,11,12, 19,20,21	Cap, Poscap	150μF, 6.3V, 40mΩ	6	6TPC150M	Sanyo	
C3,C29	Cap, Ceramic	0.1μF, Y5V, 25V	2	ECJ-2VF1E104Z	Panasonic	maco.panasonic.co.jp
C9	Cap, Ceramic	1μF, X7R, 25V	1	ECJ-3YB1E105K	Panasonic	
C24	Cap, Ceramic	2200pF, X7R, 50V	1	ECJ-2VB1H222K	Panasonic	
C34	Cap, Ceramic	6800pF, X7R, 50V	1	ECJ-2VB1H682K	Panasonic	
C14,C26	Cap, Ceramic	470pF, X7R, 50V	2	ECJ-2VC1H471J	Panasonic	
C6,7,8, 15,23,30	Cap, Ceramic	1μF, Y5V, 16V	6	ECJ-2VF1C105Z	Panasonic	
C13,C18	Cap, Tantalum	47μF, 10V	2	ECS-T1AD476R	Panasonic	
R2,4,15,18	Resistor	2.15Ω	4			
R16	Resistor	29.4K	1			
R21	Resistor	16.5K	1			
R5,R19	Resistor	4.7Ω	2			
R8	Resistor	200, 1%	1			
R7,10,12	Resistor	1K, 1%	3			
R3,R17	Resistor	5mΩ, 1W, 1%	2	ERJ-M1WSF5MOU	Panasonic	
R13	Resistor	15K	1			
R6	Resistor	10Ω	1			
R9,11,20	Resistor	Open	3			
R1	Resistor	Short, 0Ω	1			
C16,17,22, 27,28,33	Capacitor	Open	6			
D3,D5	Diode	Open	2			

\* Use these diodes for source/sink applications when the inductor current goes negative and for the fast load transient from full output load to no load.

**TEST DATA**

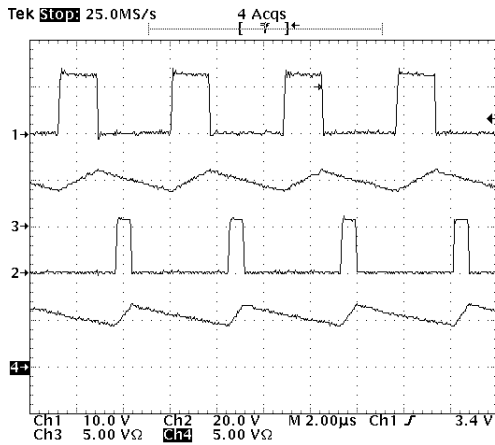

Figure 4 -  
 Ch1: Gate signal for control FET (master, pin-15).  
 Ch2: Gate signal for control FET (slave, pin-10).  
 Ch3: Inductor current for master channel (L3).  
 Ch4: Inductor current for slave channel (L4).  
 $V_{MASTER}=5V$ ,  $V_{SLAVE}=12V$ ,  $I_{OUT}=10A$

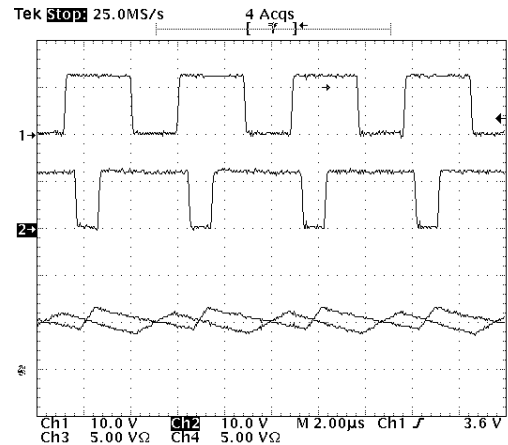

Figure 5 -  
 Ch1: Gate signal for sync FET (master, pin-14).  
 Ch2: Gate signal for sync FET (slave, pin-11).  
 Ch3: Inductor current for master channel (L3).  
 Ch4: Inductor current for slave channel (L4).  
 $V_{MASTER}=5V$ ,  $V_{SLAVE}=12V$ ,  $I_{OUT}=10A$

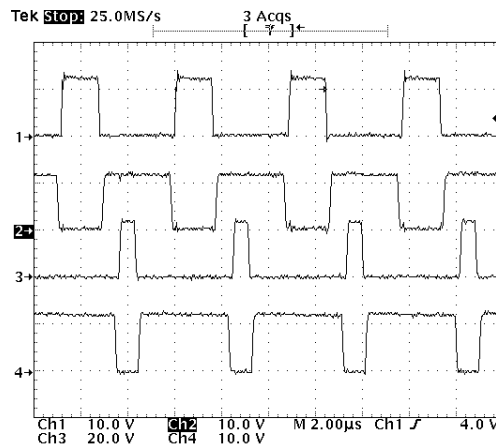

Figure 6 -  
 Ch1: Gate signal for control FET (master, pin-15).  
 Ch2: Gate signal for sync FET (master, pin-14).  
 Ch3: Gate signal for control FET (slave, pin-10).  
 Ch4: Gate signal for sync FET (slave, pin-11).

**TEST DATA**

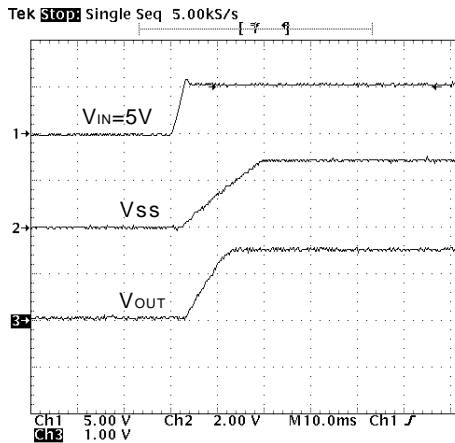

Figure 7 - Start-up @  $I_{OUT} = 10A$ .

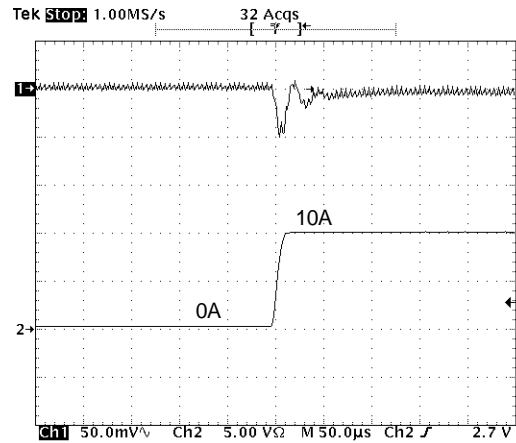

Figure 8 - Transient response @  $I_{OUT} = 0$  to  $10A$ .

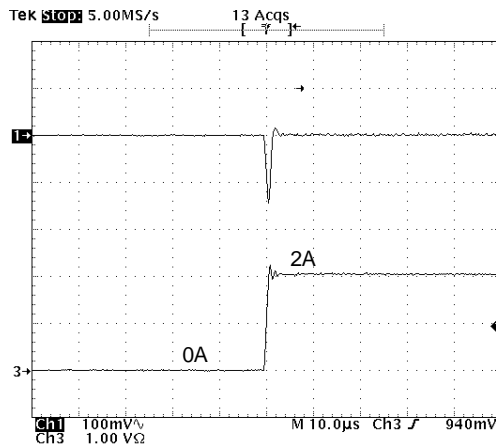

Figure 9 - Transient response for LDO @  $I_{OUT} = 0$  to  $2A$ .