

QLSP07GUC
(3535 High Power LED)



Product Outline:

QLSP07XXU series are color LEDs bring high performance and quality of light to wide range of lighting application. The lighting application such as cation light, decoration light, signal, specific industrial and commercial lighting.

Features:

- Green color
- High brightness output @ 350mA,
- High driving current to 1000mA
- Package Dimension = 3.5mmX3.5mmX1.9mm
- Low thermal resistance : <math><8^{\circ}\text{C}/\text{W}</math>
- ESD protection up to 4KV
- RoHS compliant
- Custom Bin available upon special request

Application:

- Architecture Lighting
- Garden Lighting
- Warming lamp
- Indoor Lighting
- Outdoor Lighting

Compliance and Certification:



Mechanical Property: (Dimension)

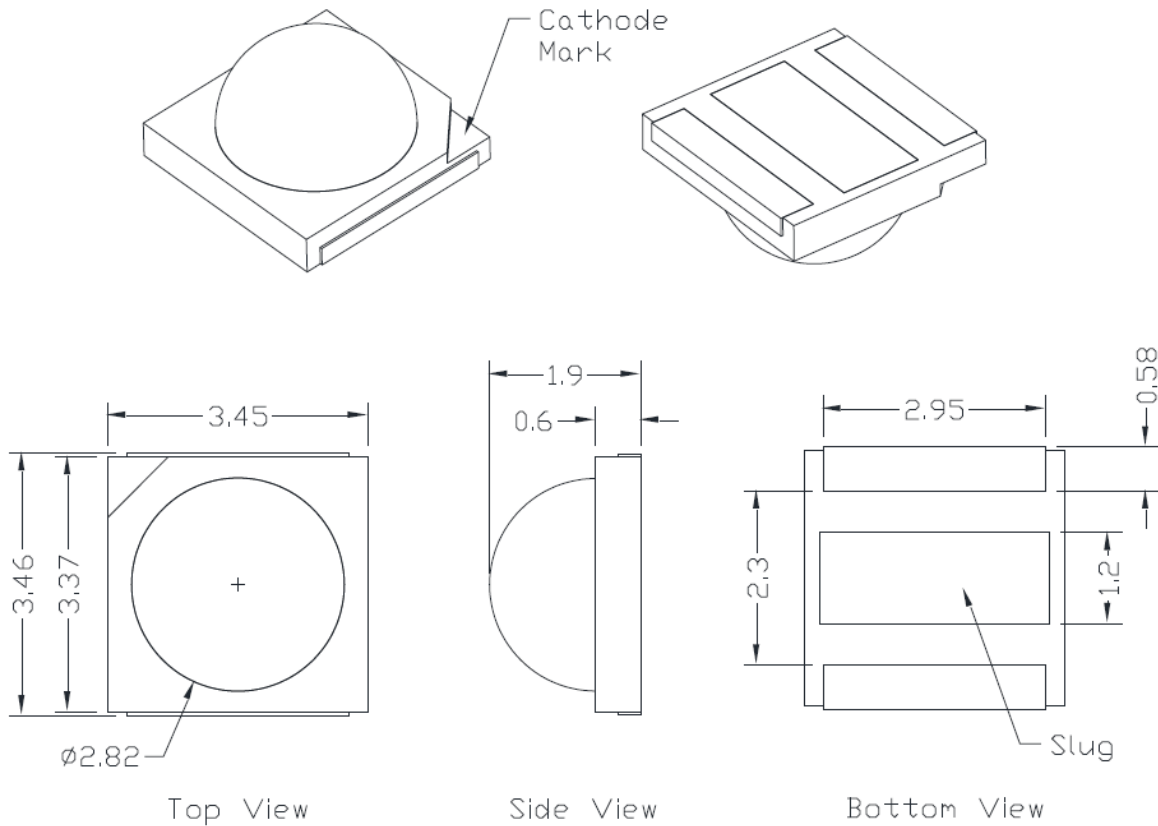

Circuit Diagram (G,C,B,D)

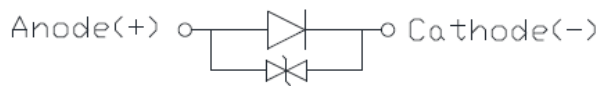

Recommended Solder footprint:

Recommended PCB solder pad:

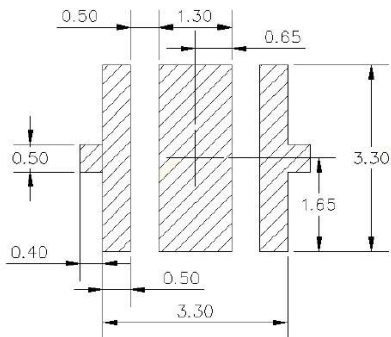

RECOMMENDED PCB SOLDER PAD

Recommended stencil pattern:

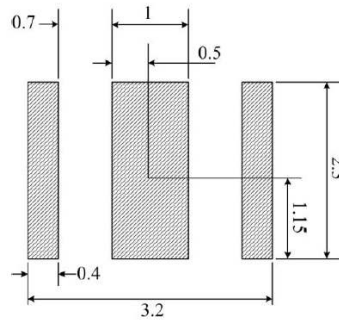

RECOMMENDED STENCIL PATTERN
(HATCHED AREA IS OPENING)

Electrical / Optical Characteristic

(T=25 °C)

Product	Color	I _F (mA)	V _F (V)		Wd nm	Luminous Flux(lm)		Refer @ 700mA Typ.(lm)
			Typ.	max		min	typ.	
QLSP07GUC	Green	350	3.2	3.5	515~535	90	120	195

*Tolerance = +/- 10%

Absolute Maximum Rating

(T=25 °C)

Part #	P _d (mW)	I _F (mA)	I _{FP} (mA)*	V _R (V)	T _j (°C)	TOP (°C)	T _{ST} (°C)	T _{SOL} (°C)**	R _{th(J-S)} (C/W)***
QLSP07GUC	4000	1000	1000	5	120	-40 - 85	-40 - 120	260	8

*Duty 1/10 @ 10Khz

** IR Reflow for no more than 10 sec @ 260 °C

*** Junction to substrate



Dominate Wavelength (nm) Bin:

Wd (nm)			
Color	Code name	Min.	Max.
Green	DM	515	520
	DN	520	525
	DP	525	530

Measurement tolerance is +/- 1nm

Forward Voltage (VF) Bin:

VF Rank (V)			
Color	Code name	Low	High
Green	A	2.85	3.1
	B	3.1	3.35
	C	3.35	3.6

The forward voltage tolerance is ± 0.1V

Luminous Flux Bin:

Rank @350mA (lm)			
Color	Code name	Low	High
Green	QX9	100	110
	QY9	110	120
	QZ9	120	130

luminous flux tolerance is ± 7%



Characteristic Curves

(1) Color Spectrum

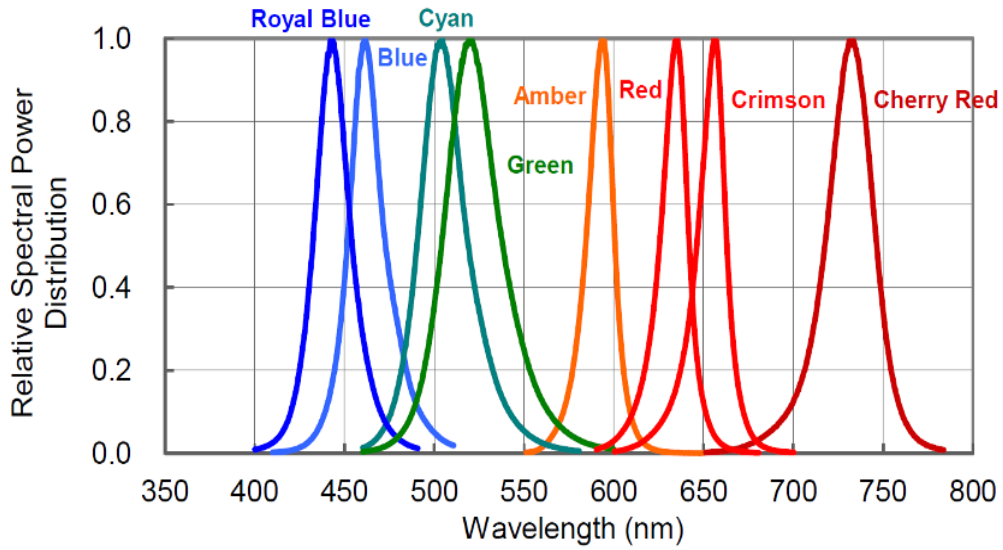

(2). Typical Representative Spatial Radiation Pattern

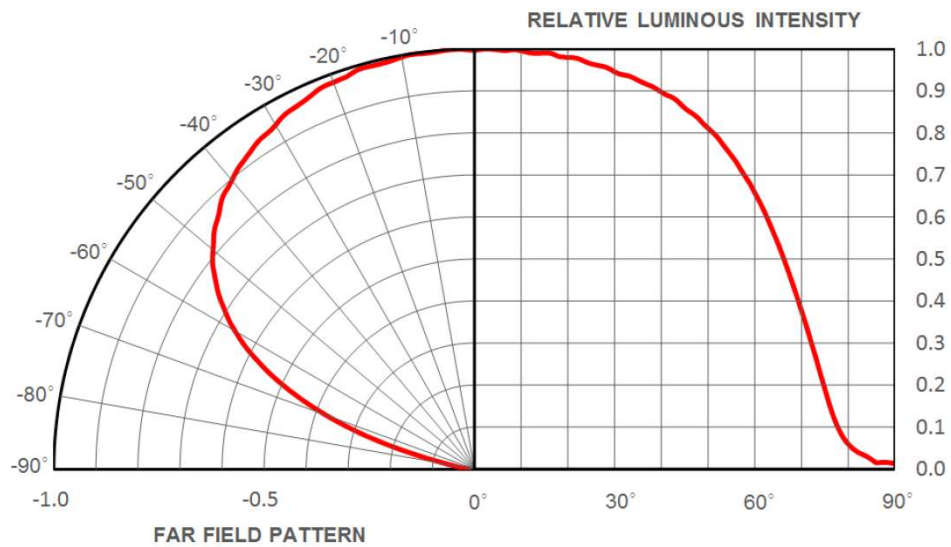

(3). Forward Current Characteristics

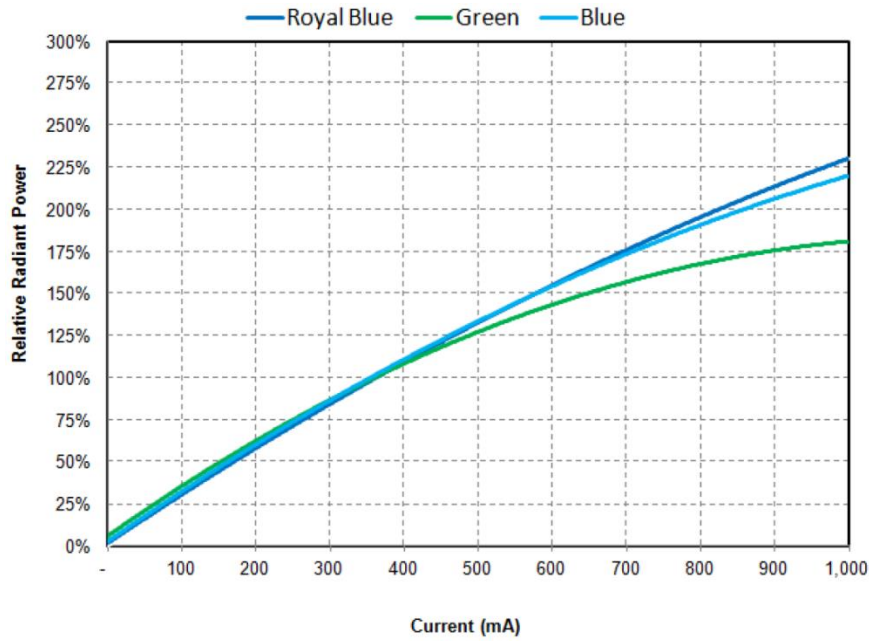

(4). Forward Current vs Forward Voltage

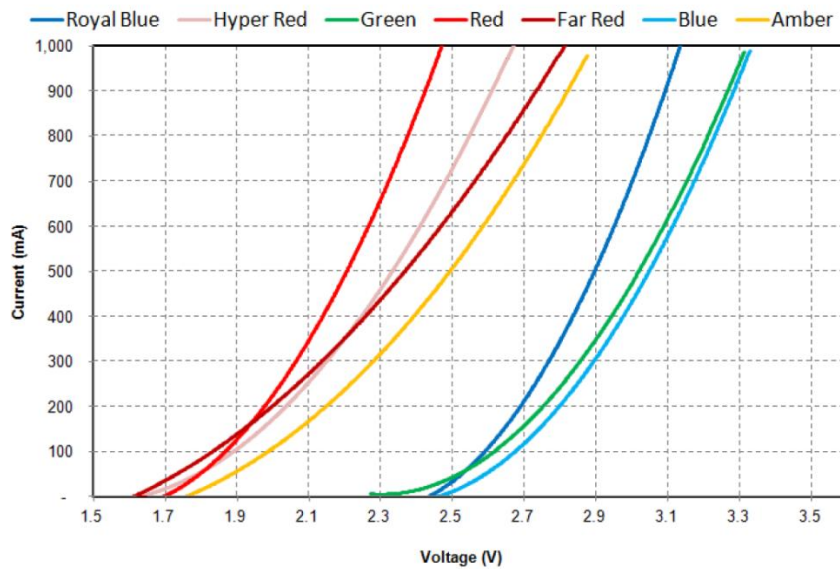

■ Reliability test:

No	Item	Condition	Time/Cycle	Sample size
1	Steady State Operating Life of Room Temperature	25°C Operating	1000 Hrs	20 pcs
2	Steady State Operating Life of Low Temperature -40°C	-40°C Operating	1000 Hrs	20 pcs
3	Steady State Operating Life of Low Temperature 60°C	60°C Operating	1000 Hrs	20 pcs
4	Steady State Operating Life of Low Temperature 85°C	85°C Operating	1000 Hrs	20 pcs
5	Low temperature storage -40°C	-40°C Storage	1000 Hrs	20 pcs
6	High temperature storage 100°C	100°C Storage	1000 Hrs	20 pcs
7	Steady State Operating Life of High Humidity Heat 60°C 90%	60°C/90% Operating	1000 Hrs	20 pcs
8	Steady State Pulse Operating Life Condition	25°C 10Hz duty=1/10 Operating	200 Cycle	20 pcs
9	Resistance to soldering heat on PCB (JEDEC MSL3)	pre-store@60°C, 60%RH for 52hrs T _{sld} max.=260 10sec	3 Times	20 pcs
10	Heat Cycle Test (JEDEC MRC)	25°C~65°C~-10°C, 90%RH, 24hr/1cycle	10 Cycle	20 pcs
11	Thermal shock	-40°C/ 20minr~ 5minr~100°C /20min	300 Cycle	20 pcs

■ Judgment Criteria:

Item	Symbol	Test Condition	Judgment Criteria
Forward Voltage	V _f	350 mA	ΔV _f < 10%
Luminous Flux	I _v	350 mA	ΔI _v < 30%



Solder Profile:

-The recommended reflow soldering profile is as follows (temperatures indicated are as measured on the surface of the LED resin):

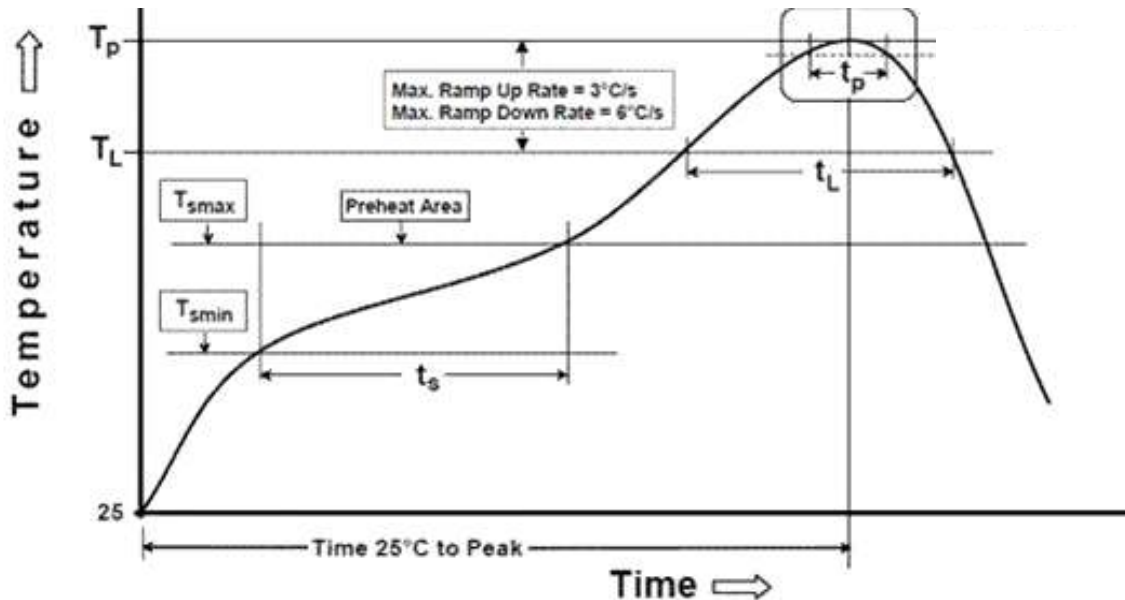

Profile Feature	Sn-Pb Eutectic Assembly	Pb-Free Assembly
Temperature Min(T_{smin})	100°C	150°C
Temperature Max(T_{smax})	150°C	200°C
Time(t_a) from (T_{smin} to T_{smax})	60-120 seconds	60-120 seconds
Ramp-up rate(T_L to T_P)	3°C/second max.	3°C/second max.
Liquidous Temperature(T_L)	183°C	217°C
Time(t_L) maintained above T_L	60-150 seconds	60-150 seconds
Peak package body temperature(T_P)	235°C	260°C
Time within 5°C of Actual Peak temperature (t_p)	20seconds*	30 seconds*
Ramp-down rate(T_P to T_L)	6°C/second max.	6°C/second max.
Time 25°C to peak temperature	6 minutes max.	8 minutes max.
* Tolerance for peak profile temperature (T_P) is defined as a supplier minimum and a user maximum.		



Taping & Packing:

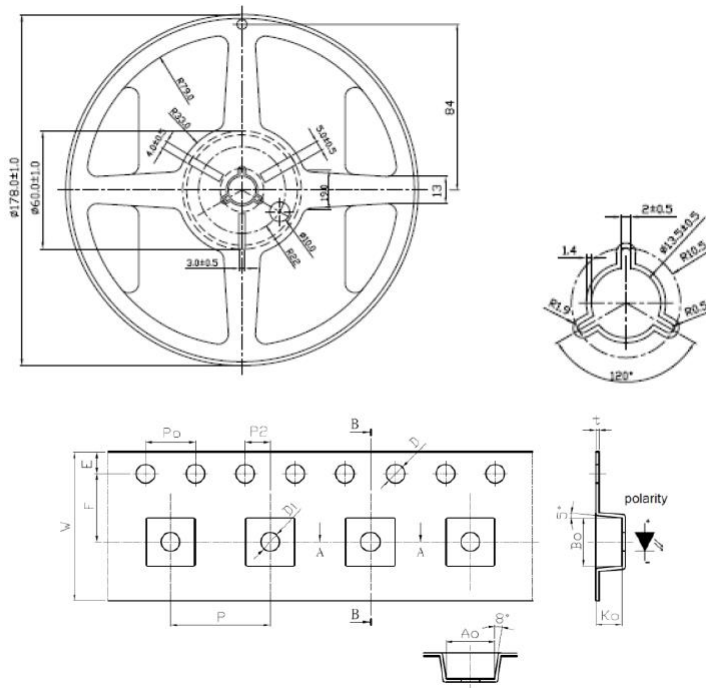

Notes: Dimensions are in millimeters.

Symbol	Dimension
W	12.00 +/- 0.10
P	8.00 +/- 0.10
E	1.75 +/- 0.10
F	5.50 +/- 0.05
P2	2.00 +/- 0.05
D	1.50+0.10 or 1.50-0.00
D1	1.50 +/- 0.10
Po	4.00 +/- 0.10
10Po	40.00 +/- 0.20
Ao	3.90 +/- 0.10
Bo	3.90 +/- 0.10
Ko	2.45 +/- 0.1
t	0.26 +/- 0.05

Unit : mm



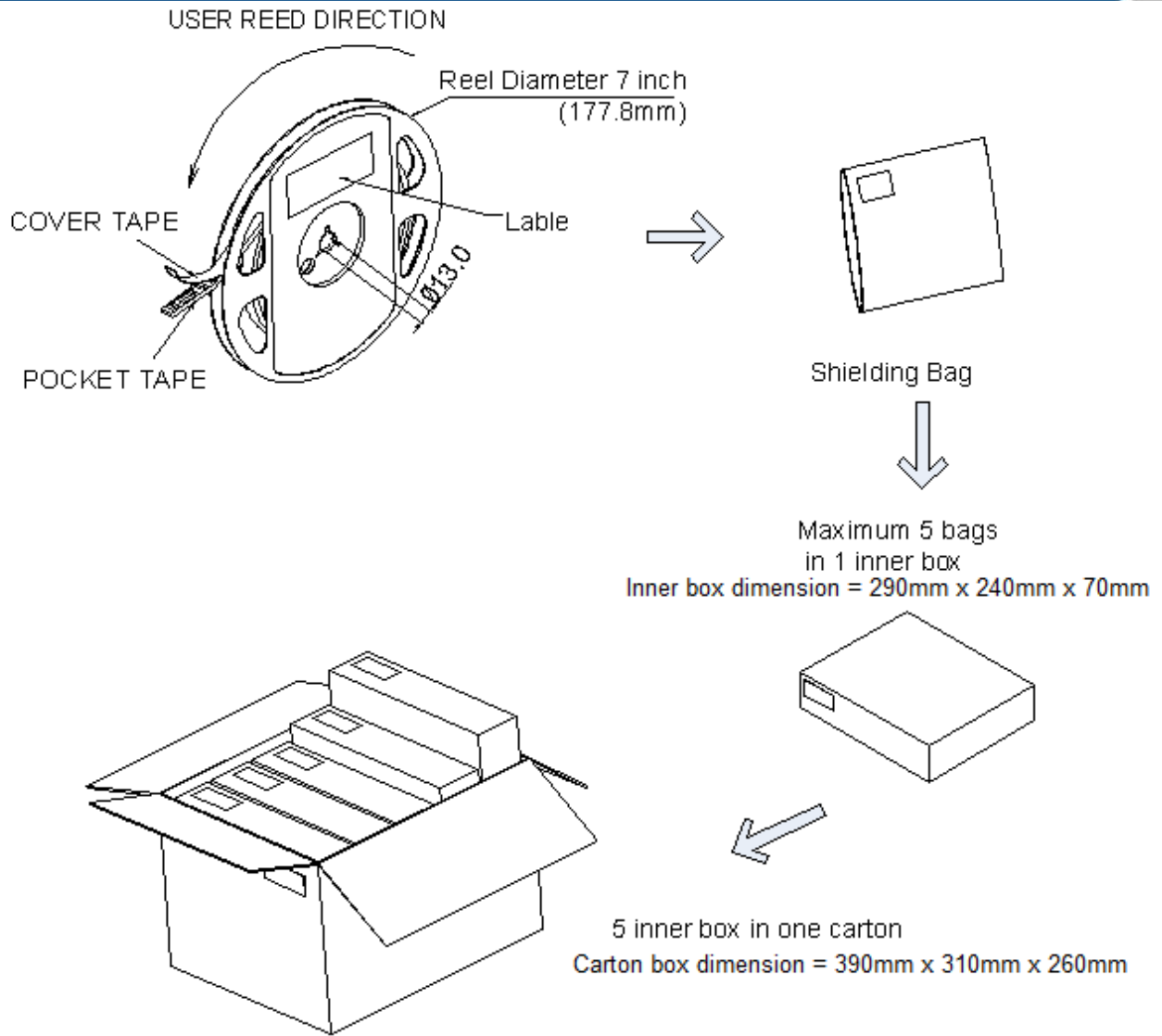

Labeling

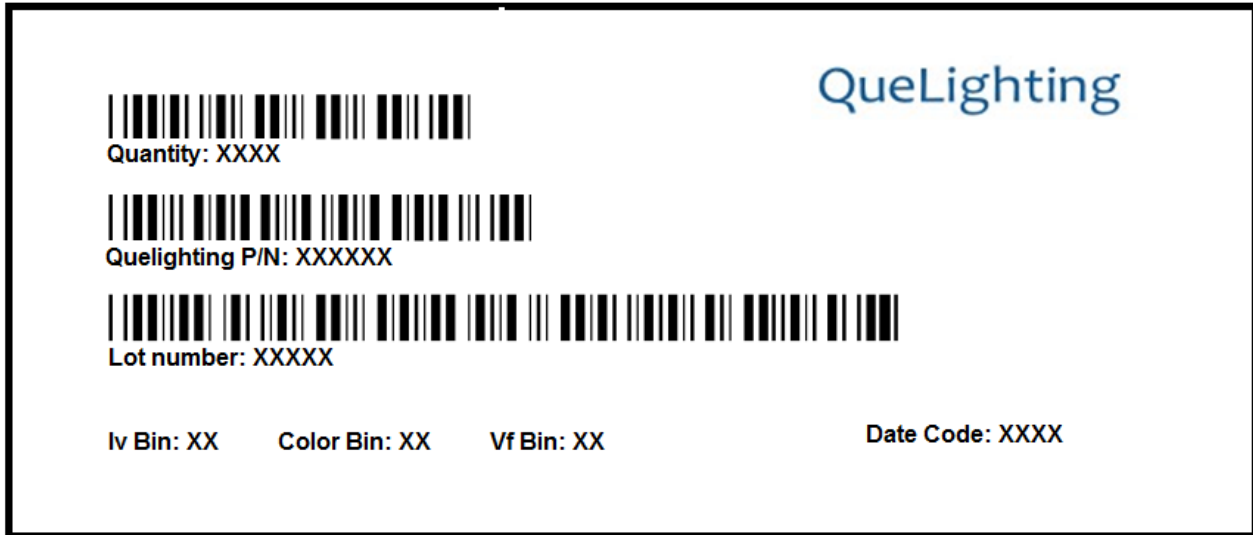

Ordering Information:

Part #	Multiple Quantities	Quantity per Reel
QLSP07GUC		250, 500,1000 pcs



Revision History:

Revision Date:	Changes:	Version #:
09-01-2017	Initial release	1.0
03-06-2019	Revise specification	1.1
08-07-2020	Update the specification	1.2
10-12-2021	Update the performance	2.0

