

- MATERIAL: HOUSING - PCT POLYESTER, BLACK, UL 94V-0. OVERMOLDED TERMINAL ARRAY - HIGH TEMPERATURE NYLON, COLOR: NATURAL. TERMINALS - 0.33[0.013] THICK PHOS BRONZE PLATED WITH 1.27um[0.000050] MIN THICK HARD GOLD IN LOCALIZED AREA AND 3.81um[0.000150] MIN THICK MATTE TIN IN SOLDER AREA OVER 1.27um[0.000050] MIN THICK NICKEL UNDERPLATE. SHIELD - 0.196[0.0077] THICK COPPER ALLOY PLATED WITH SATIN NICKEL 1.27um[0.000050] MIN THICK OVERALL AND 2.03um[0.000080] MIN THICK HOT TIN DIP ON PCB GROUND TABS.
- JACK CAVITY CONFORMS TO FCC RULES AND REGULATIONS, PART 68 SUBPART F.
- USE 3.25mm OR #30 DRILL BIT WHEN PRODUCING THESE PCB HOLES.
- DATE CODE LOCATED ON REAR OF PART APPROXIMATELY AS SHOWN: FIRST 2 DIGITS ARE LAST 2 DIGITS OF YEAR, SECOND 2 DIGITS ARE MANUFACTURING WORK WEEK, LAST DIGIT IS DAY OF WEEK WITH SUNDAY = 1.
- PARTS PACKAGED IN SEALED BAGS WITH DESICCANT
- PARTS SUITABLE FOR LEAD FREE REFLOW PROCESSING TO 260° C
- THE PART NUMBER HAS NOT COMPLETED VALIDATION TESTING, THE STATUS IS PRELIMINARY.

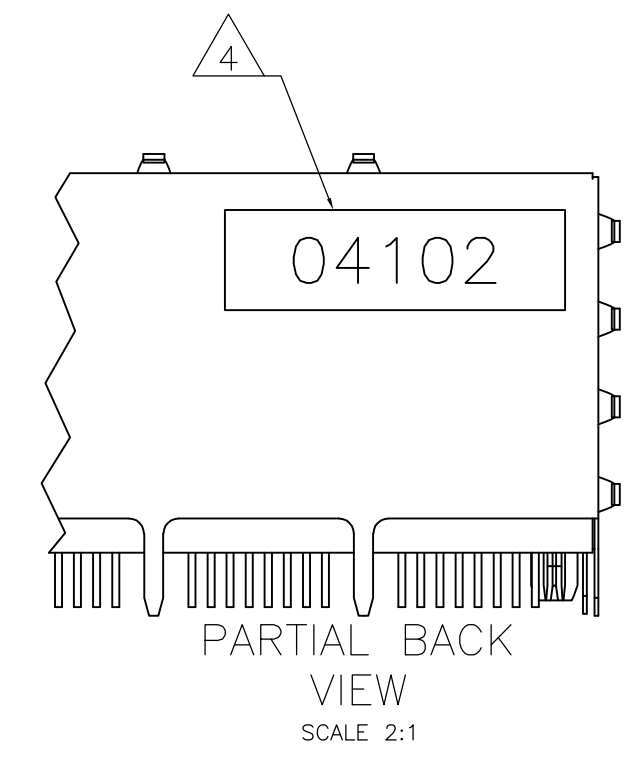

2007372-1
PART NUMBER

THIS DRAWING IS A CONTROLLED DOCUMENT.		OWN: L.V./L.A. MAYER 10JAN2008	Tyco Electronics Corporation Harrisburg, PA 17105-3608
DIMENSIONS: mm [INCHES]		CHK: J. WESTMAN 10JAN2008	
TOLERANCES UNLESS OTHERWISE SPECIFIED:		APVD: S. FLICKINGER 10JAN2008	NAME: STACKED MODULAR JACK ASSEMBLY
0 PLC ± -		PRODUCT SPEC: 108-1163-2	2x8 PORT, 8 POSITION, SHIELDED, WAVE PANEL GROUND, CATEGORY 5
1 PLC ± -		APPLICATION SPEC: 114-2048	SIZE: A1
2 PLC ± 0.25[0.01]		FINISH: SEE NOTE 1	CAGE CODE: 00779
3 PLC ± 0.13[0.005]		SCALE: 4:1	DRAWING NO: 2007372
4 PLC ± -		RESTRICTED TO: CUSTOMER DRAWING	REV: A1
ANGLES: SEE NOTE 1		SHEET 1 OF 2	

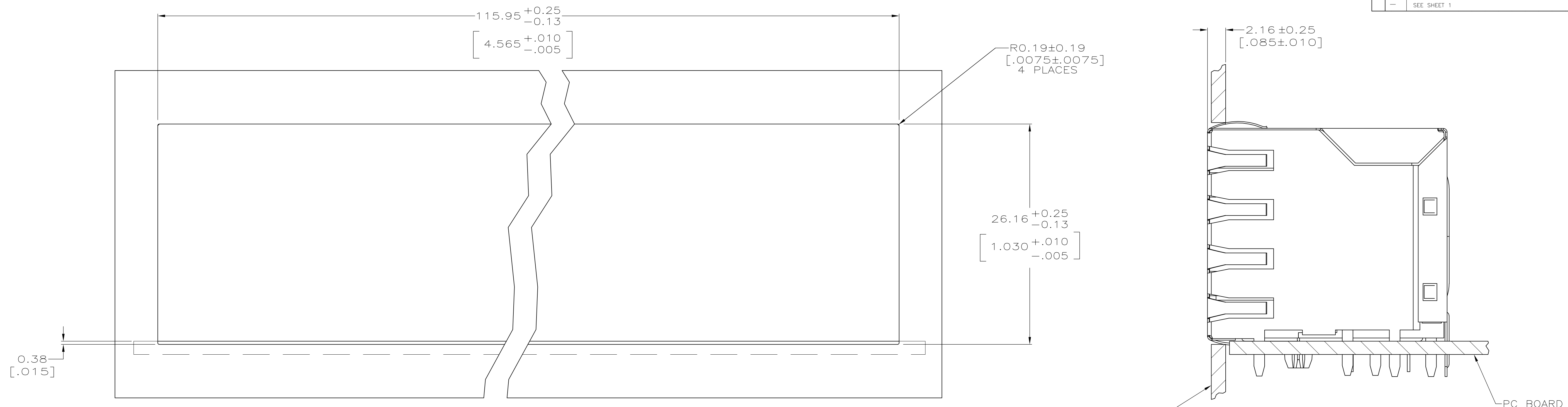

RECOMMENDED PANEL CUTOUT DIMENSIONS

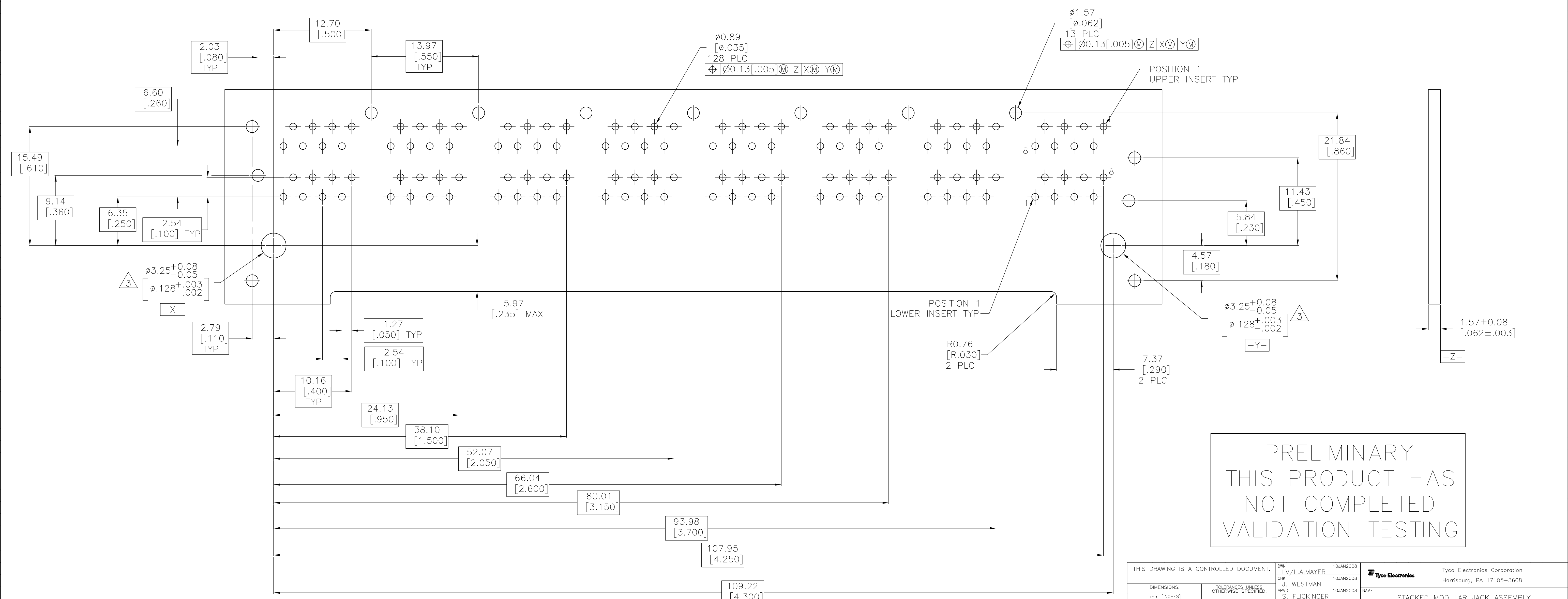

PRELIMINARY
 THIS PRODUCT HAS
 NOT COMPLETED
 VALIDATION TESTING

PC BOARD LAYOUT
 (VIEWED FROM COMPONENT SIDE)

THIS DRAWING IS A CONTROLLED DOCUMENT.		DIN	LV/LAMAYER	10JAN2008	Tyco Electronics Corporation Harrisburg, PA 17105-3608
DIMENSIONS: mm [INCHES]		CHK	J. WESTMAN	10JAN2008	
TOLERANCES UNLESS OTHERWISE SPECIFIED:		APVD	S. FLICKINGER	10JAN2008	NAME STACKED MODULAR JACK ASSEMBLY 2x8 PORT, 8 POSITION, SHIELDED, WAVE PANEL GROUND, CATEGORY 5
0 PLC ± -		PRODUCT SPEC	108-1163-2		
1 PLC ± -		APPLICATION SPEC	114-2048		SIZE A1
2 PLC ± 0.25[.01]		WEIGHT	00779		
3 PLC ± 0.13[.005]		FINISH	2007372		RESTRICTED TO CUSTOMER DRAWING
4 PLC ± -		SCALE	4:1		
ANGLES ± -		SHEET	2 OF 2		
SEE NOTE 1		REV	A1		