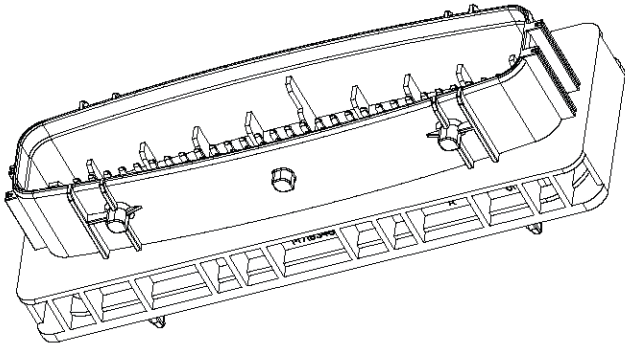

**Oversea transport of 120p****1. SCOPE / DOEL**

This specification describes the transport packaging from the **TE Oostkamp to over sea customers** for the ASSY 1.5x0.64 TAB HOUSING 120 POS and possible variants.

*Deze specificatie beschrijft de verpakking voor het transport van **TE Oostkamp naar overzee klanten** voor de ASSY 1.5x0.64 TAB HOUSING 120 POS en mogelijke varianten.*

TE PN	Description / Omschrijving
1-1718345-9	ASSY 1.5x0.64 TAB HOUSING 120 POS
	

**1.1 IMPORTANT / BELANGRIJK**

1. Only one PN is allowed on a pallet. No mixed pallets are allowed.
2. Don't put various revisions on one pallet.
3. Cleanliness is to be respected.

1. *Er is slechts 1 PN toegelaten per pallet. Er mogen in geen geval verschillende PN 's op 1 pallet verzonden worden.*
2. *Verschillende revisies mogen niet op 1 pallet voorkomen.*
3. *Alles dient proper te blijven.*

**1.2 AMOUNT OF PARTS PER PALLET / AANTAL DELEN PER PALLET**

TE PN	Description	Amount of parts per box	Amount of parts per pallet
1-1718345-9	ASSY 1.5x0.64 TAB HOUSING 120 POS	42	840

Opsteller: Joeri Van Bijlen

Datum 05-02-2014

Vrijgave: Ben Dubois

Datum 09-02-2022

© Tyco Electronics Corporation  
Harrisburg, PA  
All International Rights Reserved

\*Trademark

This is a Class II confidential document belonging to Tyco Electronics Corporation. A Class II document may not be disclosed to any non-Tyco Electronics persons without (1) the written approval of a Tyco Electronics manager and (2) the signing of a Confidential Disclosure Agreement.

File:  
E:\ENGapps\TECworker\jobs\US194AP391\674395  
\107-90864-02 RevB 120p oversea.doc

Pag. 1 / 3

**2. TRANSPORT FROM TE OOSTKAMP TO CLIENT**  
**TRANSPORT VAN TE OOSTKAMP NAAR KLANT**

**2.1 BOM for 1 pallet and 1 box / MATERIALELIJST voor 1 pallet en 1 doos**

PN	Description / Omschrijving	Amount/pallet Aantal/pallet	Amount/box Aantal/doos
2-741102-1	Pallet / V2 pallet 1200x800 mm	1	
1-2236741-3	E, TRAY F, TAB HOUSING 120 POS	120	6
973056-1	EMEA Standard Box / Kartonnen doos 600x400x200 mm	20	1
740045-2	Paper cushion / papierkussen 375x275mm	120	6
973163-1	Layer pad / Kartonnen plaat 575x375 mm	20	1
999639-1W	3S Label / 3S Etiket 100 x 100 mm	20	1

**2.2 INSTRUCTIONS OPS / RICHTLIJNEN OPS**



Fill the tray with 7 parts.  
*Vul de blister met 7 delen.*



The parts must be orientated as shown on the pictures so with the plastic pimples always on the bottom (**red marking**).



*De delen moeten steeds geïoriënteerd zijn volgens de nevenstaande foto's dus met de kunststof pimpels naar beneden (**rode aanduiding**).*



Put a layer pad on the bottom, fill the box with 2 piles of 3 trays each and place 4 folded paper cushions between the stacks.

*Leg een kartonnen plaat op de bodem, vul de doos met 2 stapels van telkens 3 blisters en plaats 4 gevouwen papierkussens tussen beide stapels.*



Place 2 paper cushions on top of the trays.

*Leg 2 papierkussens bovenop de blisters.*



Close the box with tape (50 mm wide). Stick the label onto the box as indicated on the box (place ID).

*Kleef de doos toe met plakband (50 mm breed). Kleef het etiket op de daartoe voorziene plaats (Plaats ID).*



Place the box onto the pallet, label on the outside. Put 4 boxes per layer. Stack 5 layers high.

*Plaats de doos op de pallet, etiket aan de buitenkant van de pallet. Stapel 4 dozen per laag. Stapel 5 lagen hoog.*