

REVISIONS					
P	LTR	DESCRIPTION	DATE	DWN	APVD
G		REVISED PER ECN-23-198291	21MAR2023	GSK	MD

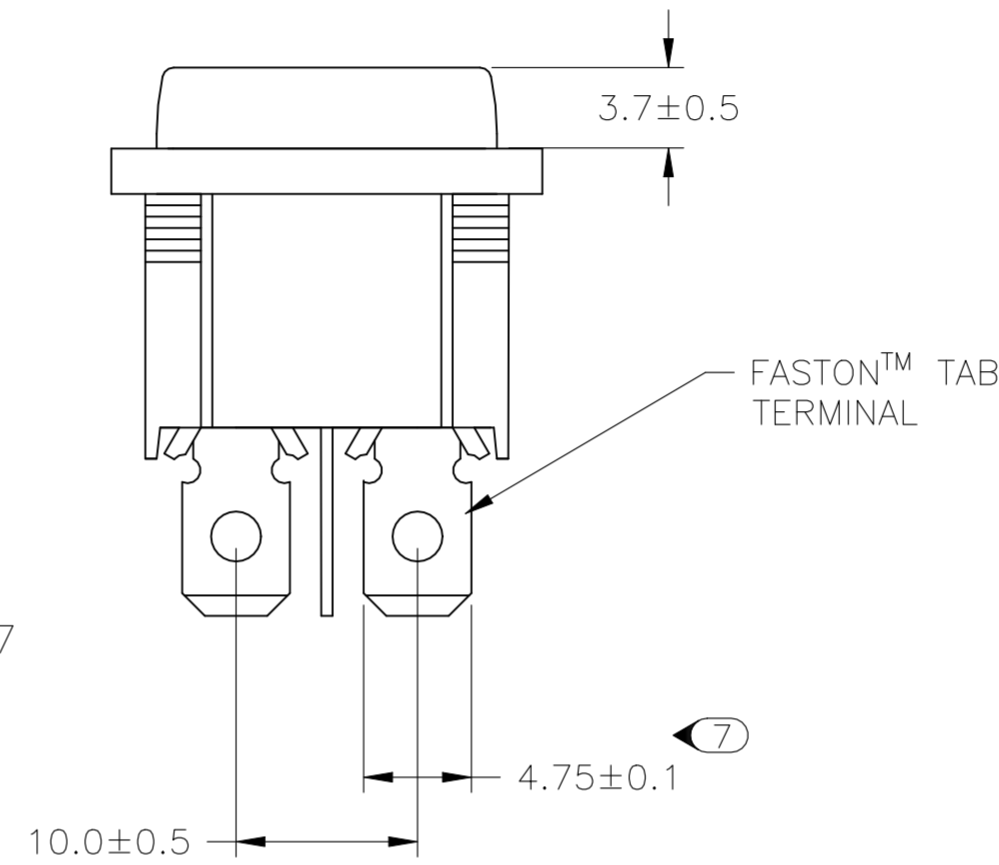

PANEL CUT OUT

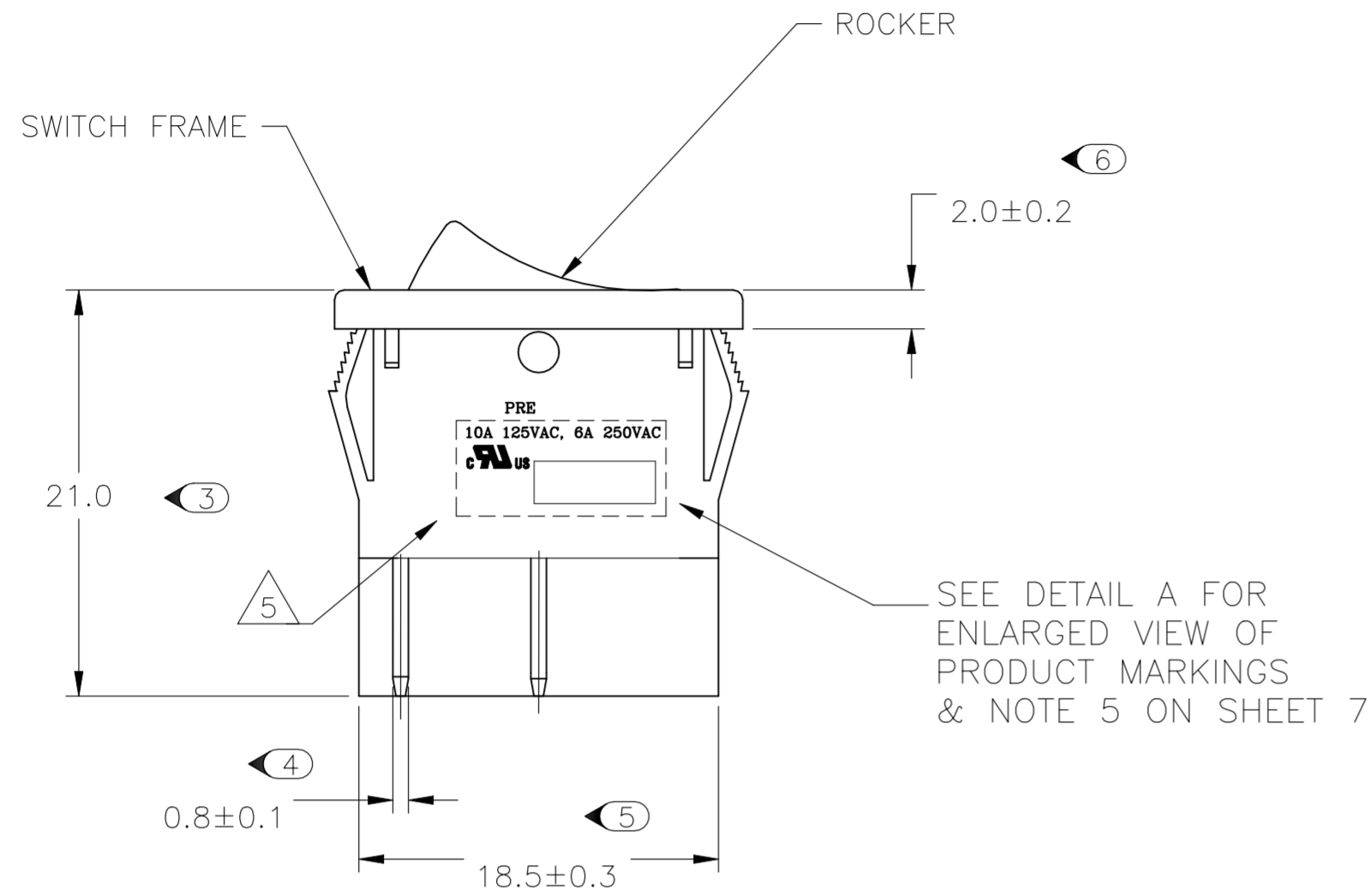
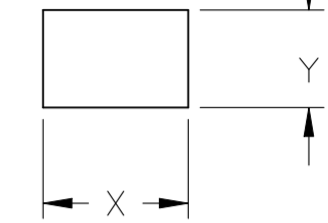

2.00-3.00	20.20	22.20
1.25-2.00	19.60	22.20
0.75-1.25	19.40	22.20
PANEL THICKNESS	X	Y

CIRCUIT DIAGRAM

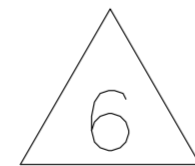
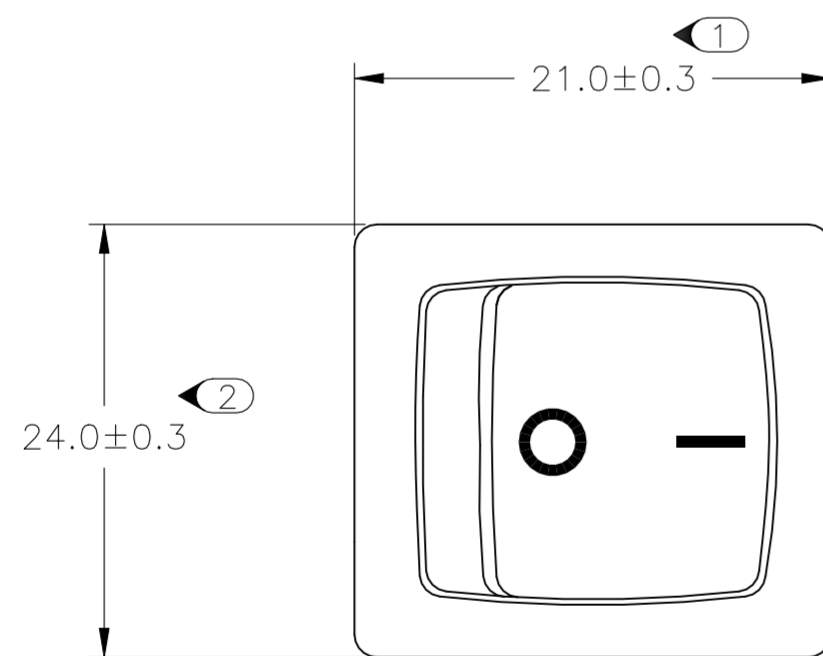
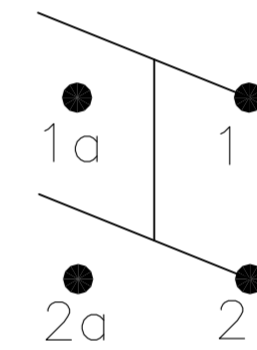

1634200-2 SHOWN ON-OFF

**PRODUCT MARKING
DETAIL A**

PRE
10A 125VAC, 6A 250VAC
CAUS

TYCO ELECTRONICS LOGO
PER TEC-202-36

THIS DRAWING IS A CONTROLLED DOCUMENT.		DWN SA008712 2-4-07	TE Connectivity	
DIMENSIONS: mm		CHK -	NAME POWER ROCKER SWITCH 19,4MM X 22,2mm PANEL SIZE DPST, NON-ILLUMINATED	
TOLERANCES UNLESS OTHERWISE SPECIFIED:		APVD -	RESTRICTED TO -	
0 PLC ± -		PRODUCT SPEC -	SIZE A2	CAGE CODE 00779
1 PLC ± -		APPLICATION SPEC -	DRAWING NO C=1634200	SHEET 1 OF 7
2 PLC ± -		WEIGHT -	SCALE 3:1	REV G
3 PLC ± -		CUSTOMER DRAWING		
4 PLC ± -				
ANGLES ± -				
FINISH -				

REVISIONS					
P	LTR	DESCRIPTION	DATE	DWN	APVD
-	-	SEE SHEET 1	-	-	-

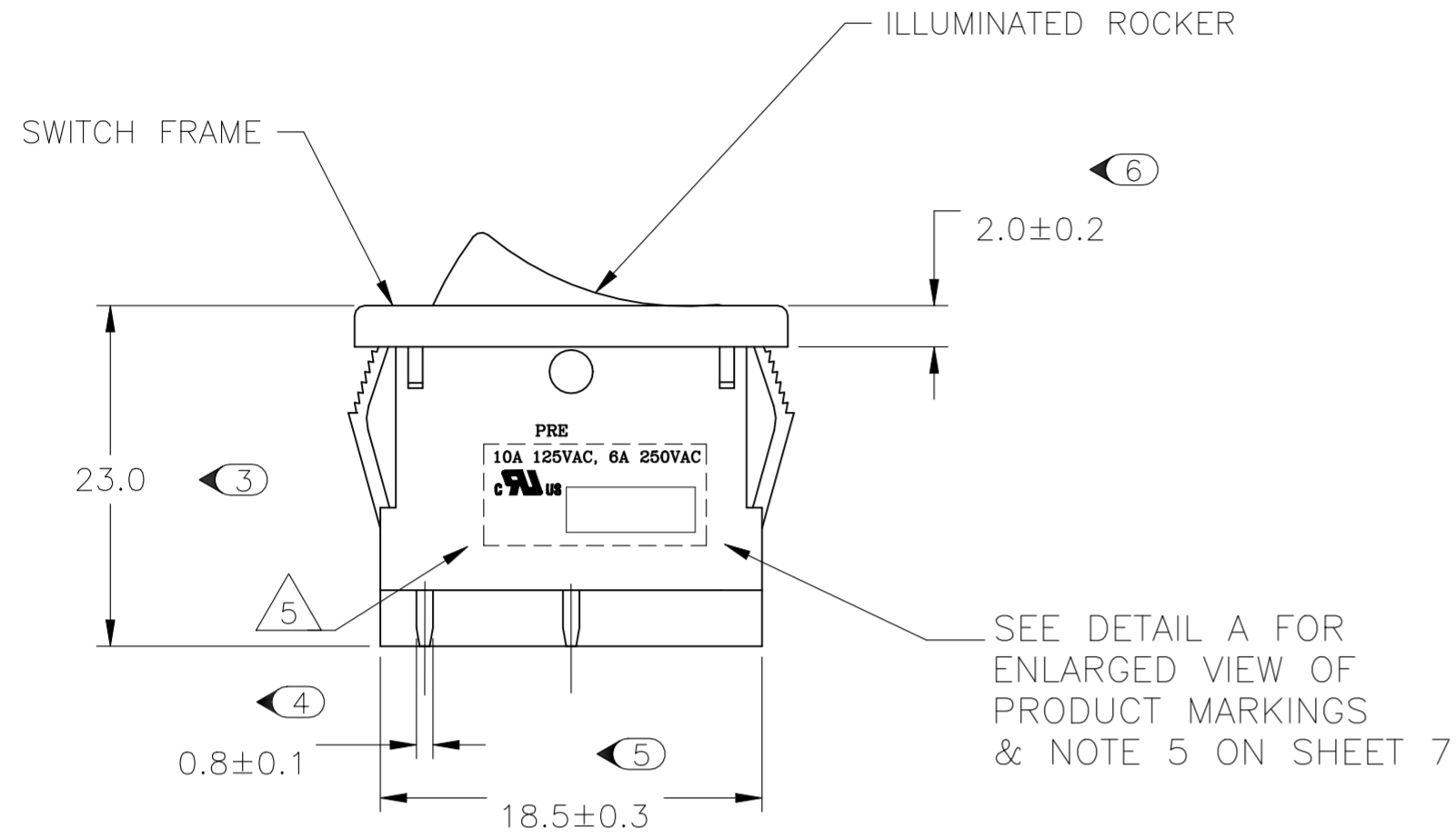

SEE DETAIL A FOR ENLARGED VIEW OF PRODUCT MARKINGS & NOTE 5 ON SHEET 7

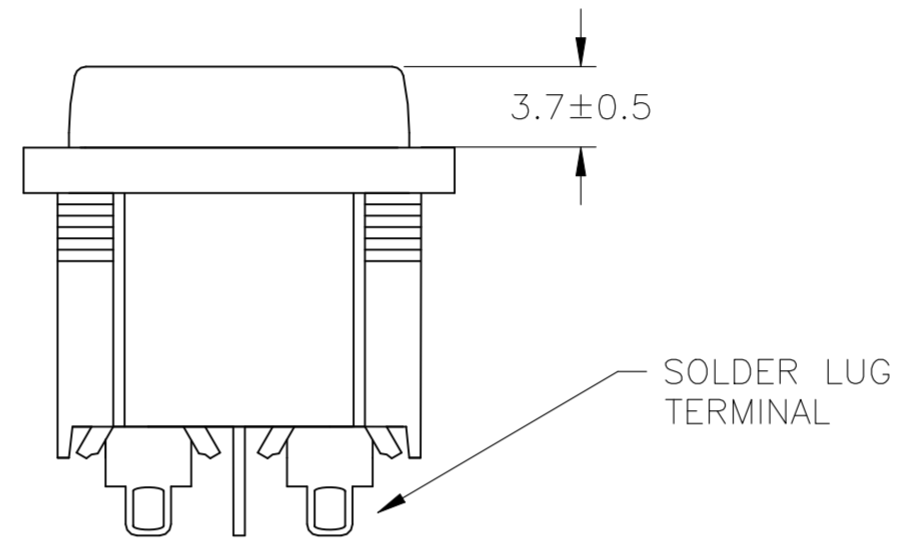

PANEL CUT OUT

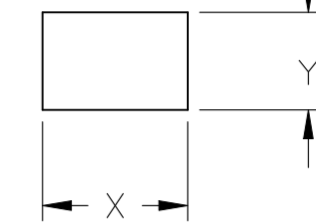

2.00-3.00	20.20	22.20
1.25-2.00	19.60	22.20
0.75-1.25	19.40	22.20
PANEL THICKNESS	X	Y

CIRCUIT DIAGRAM

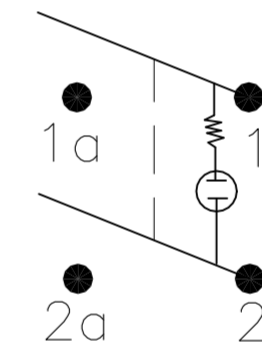

**PRODUCT MARKING
DETAIL A**

**PRE
10A 125VAC, 6A 250VAC**



TYCO ELECTRONICS LOGO
PER TEC-202-36

7 OBSOLETE 1634200-8 SHOWN ON-OFF ILLUMINATED

THIS DRAWING IS A CONTROLLED DOCUMENT.		DWN SA008712	2-4-07		
DIMENSIONS: mm		CHK -	APVD -		
TOLERANCES UNLESS OTHERWISE SPECIFIED:		PRODUCT SPEC		POWER ROCKER SWITCH 19,4MM X 22,2mm PANEL SIZE DPST, NON-ILLUMINATED	
0 PLC ± -		APPLICATION SPEC		SIZE	RESTRICTED TO
1 PLC ± -		MATERIAL		CAGE CODE	A2 00779
2 PLC ± -		FINISH		DRAWING NO	
3 PLC ± -		WEIGHT		SCALE	C=1634200
4 PLC ± -		CUSTOMER DRAWING		SHEET	
ANGLES ± -		SCALE 3:1		REV	G
FINISH		SHEET 2 OF 7			

REVISIONS					
P	LTR	DESCRIPTION	DATE	DWN	APVD
-	-	SEE SHEET 1	-	-	-

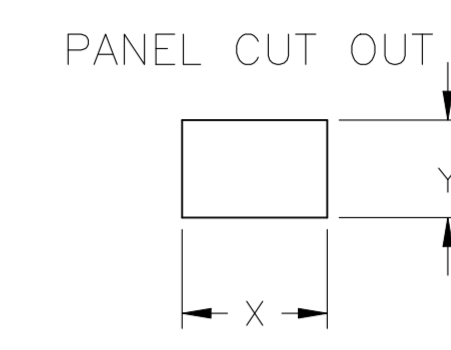
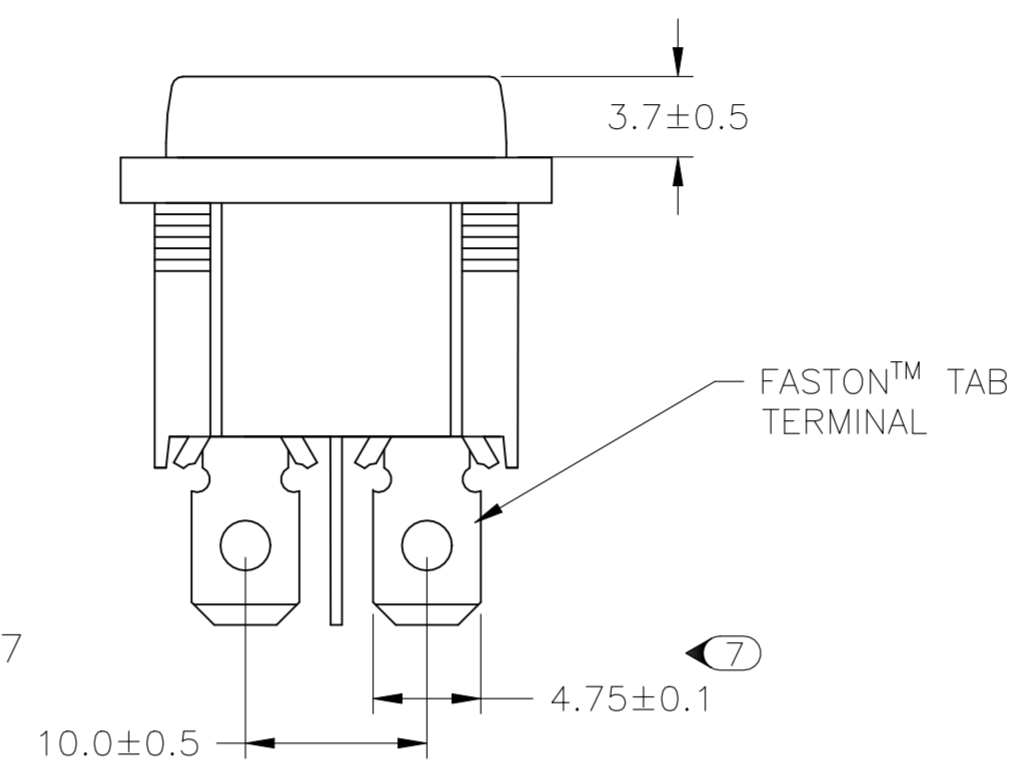
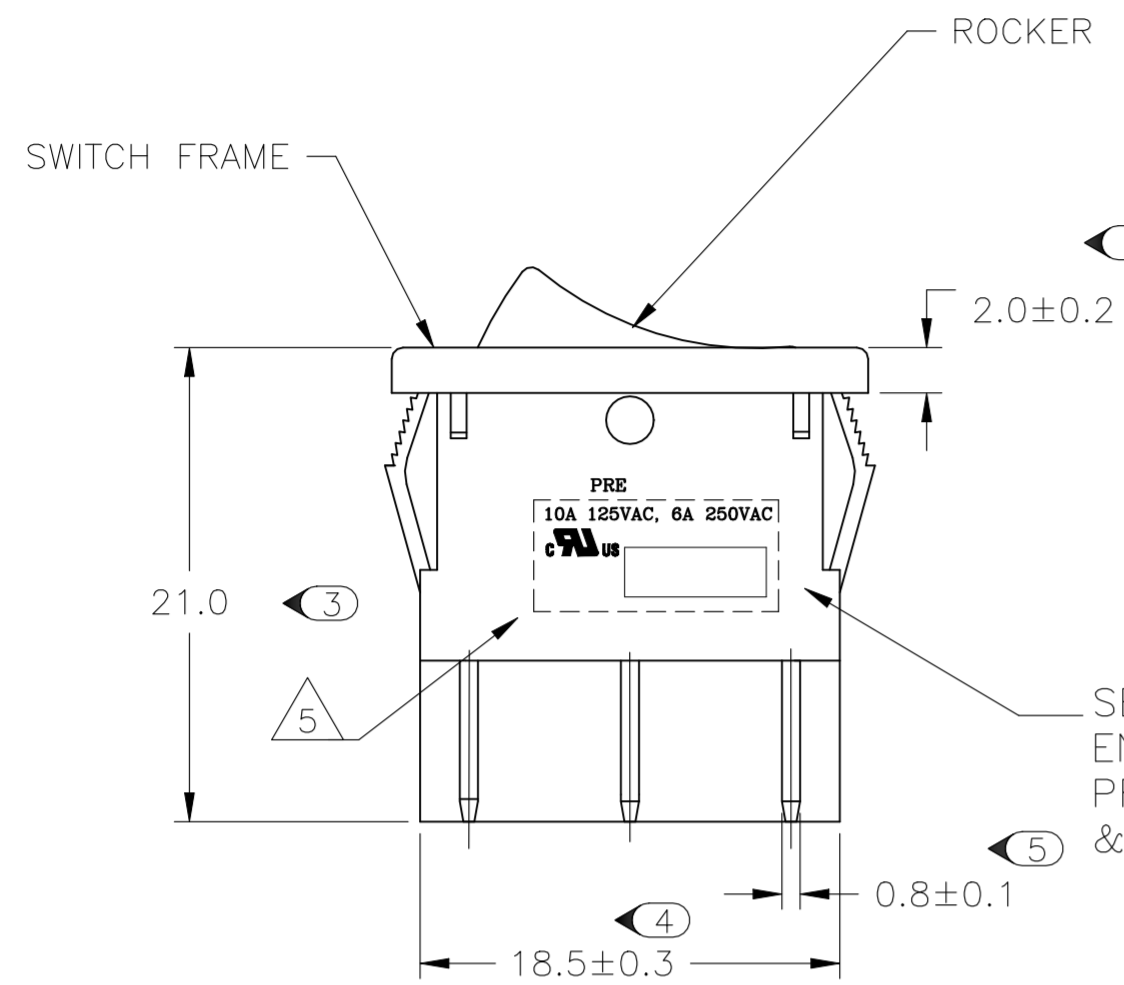

2.00-3.00	20.20	22.20
1.25-2.00	19.60	22.20
0.75-1.25	19.40	22.20
PANEL THICKNESS	X	Y

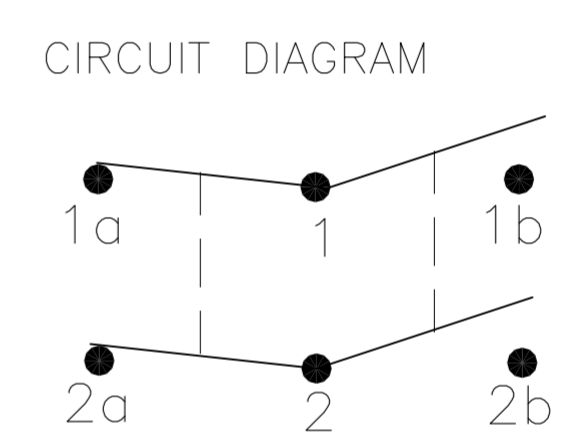
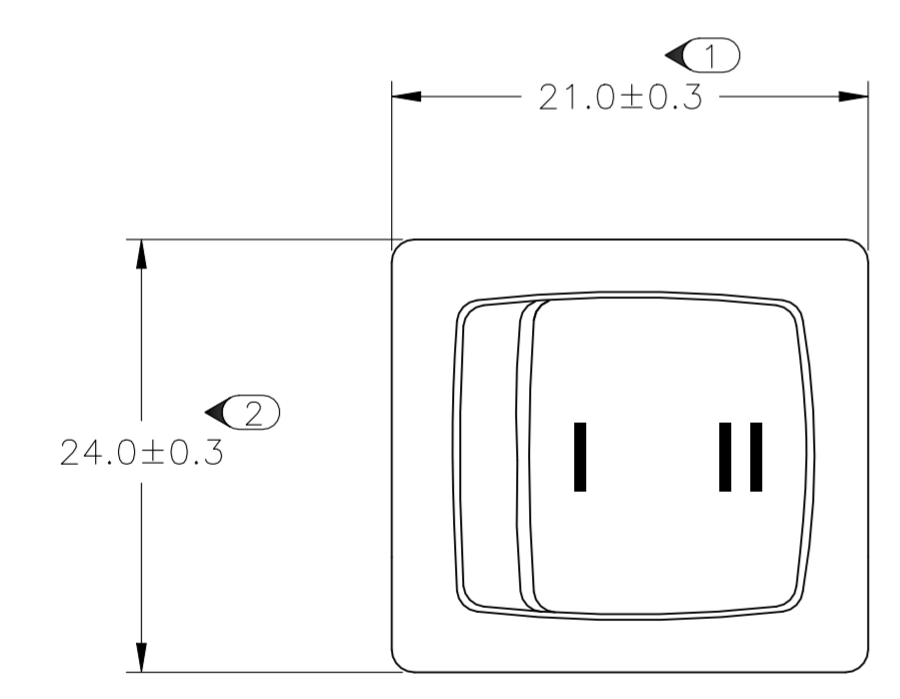

**PRODUCT MARKING
DETAIL A**

**PRE
10A 125VAC, 6A 250VAC**



TYCO ELECTRONICS LOGO
PER TEC-202-36

8 1-1634200-2 SHOWN ON-ON

THIS DRAWING IS A CONTROLLED DOCUMENT.		DWN SA008712 2-4-07	TE Connectivity	
DIMENSIONS: mm		CHK -	NAME	
TOLERANCES UNLESS OTHERWISE SPECIFIED:		APVD -	POWER ROCKER SWITCH 19,4MM X 22,2mm PANEL SIZE DPST, NON-ILLUMINATED	
0 PLC ± -		PRODUCT SPEC -	SIZE A2	CAGE CODE 00779
1 PLC ± -		APPLICATION SPEC -	DRAWING NO C=1634200	RESTRICTED TO -
2 PLC ± -		WEIGHT -	SCALE 3:1	SHEET 3 OF 7
3 PLC ± -		CUSTOMER DRAWING	REV G	
4 PLC ± -				
ANGLES ± -				
FINISH -				

REVISIONS					
P	LTR	DESCRIPTION	DATE	DWN	APVD
-	-	SEE SHEET 1	-	-	-

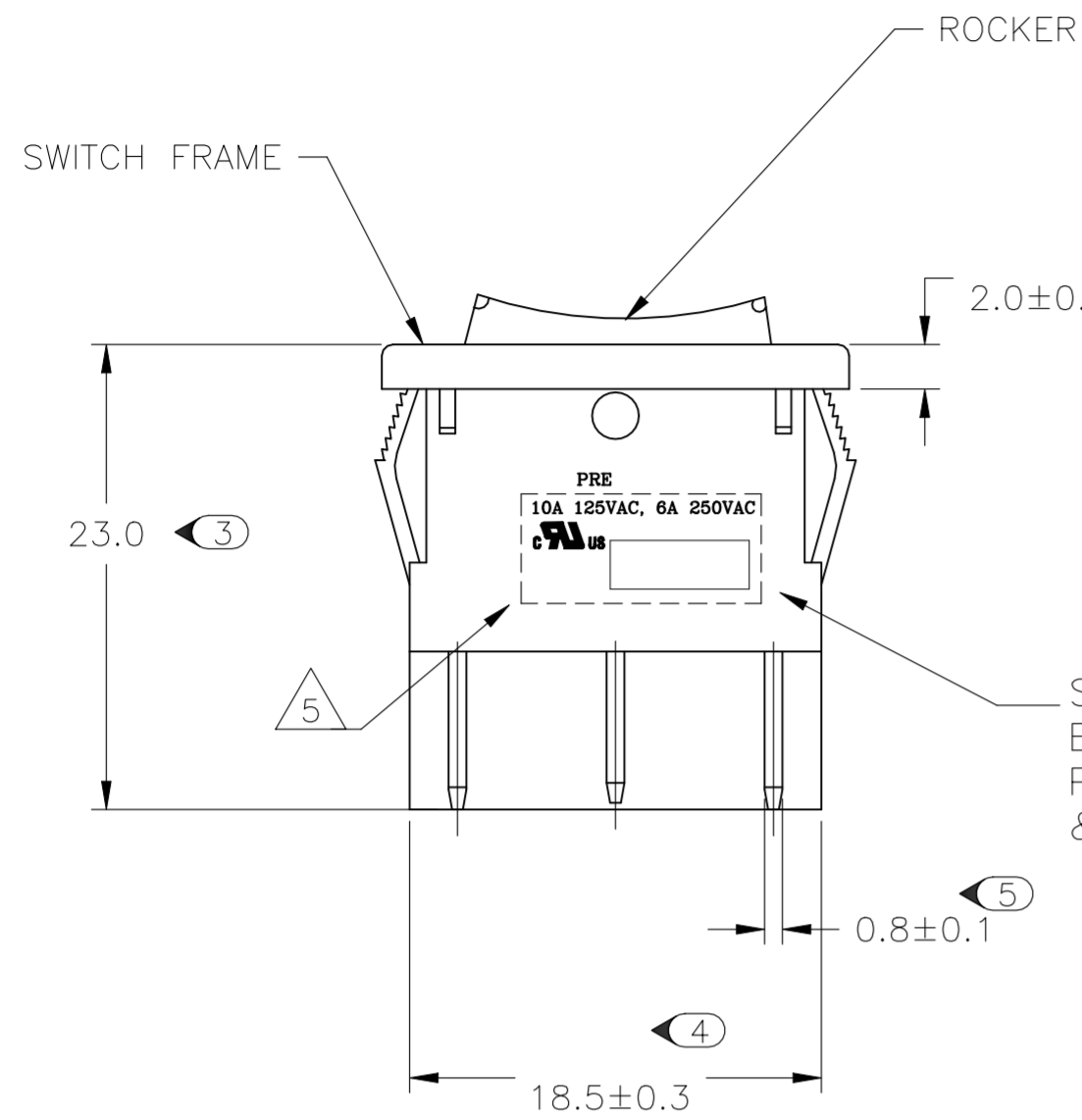

SEE DETAIL A FOR ENLARGED VIEW OF PRODUCT MARKINGS & NOTE 5 ON SHEET 7

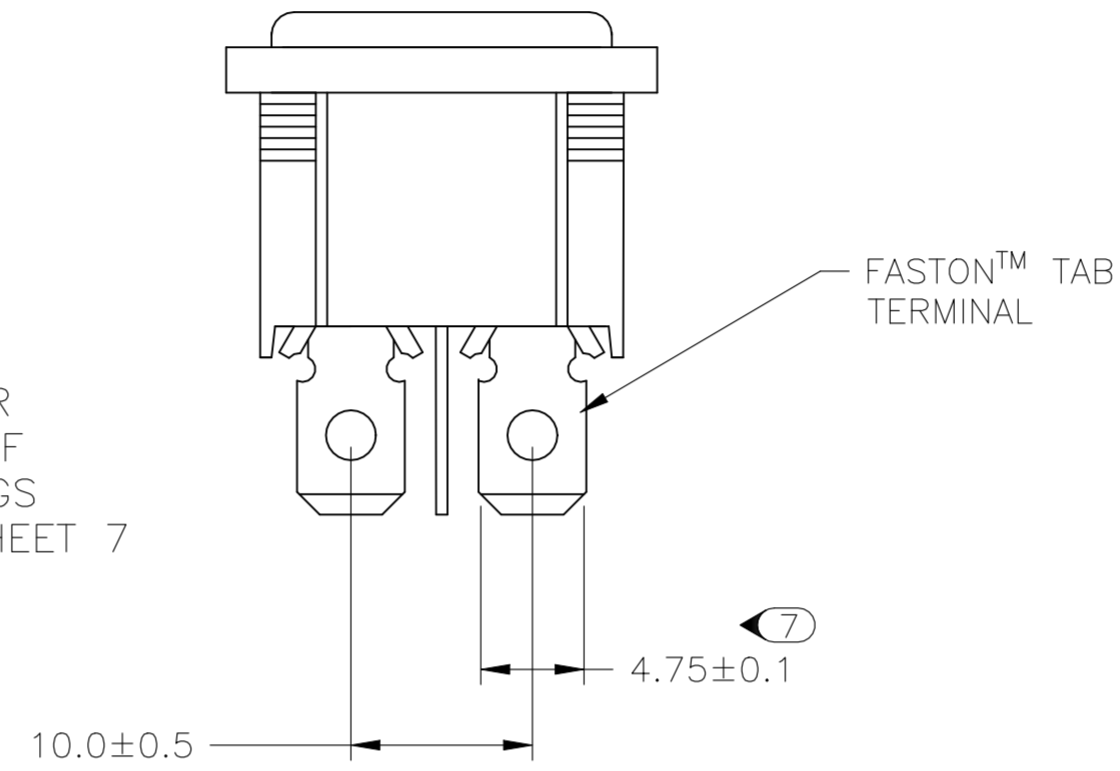

PANEL CUT OUT

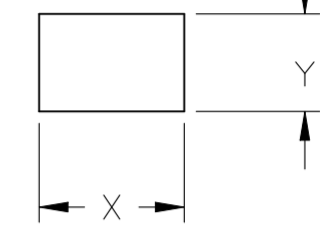

2.00-3.00	20.20	22.20
1.25-2.00	19.60	22.20
0.75-1.25	19.40	22.20
PANEL THICKNESS	X	Y

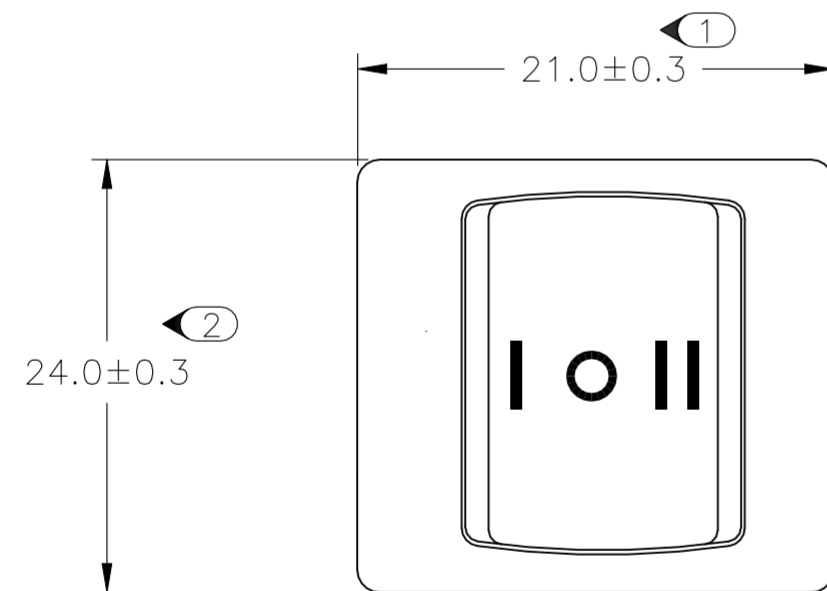

CIRCUIT DIAGRAM

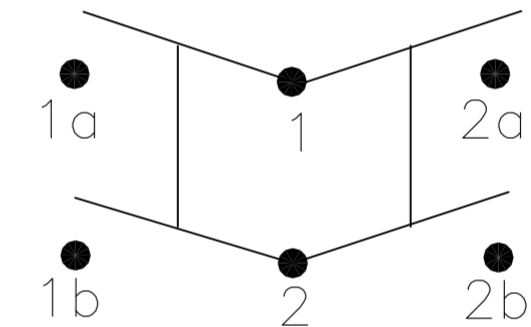

**PRODUCT MARKING
DETAIL A**

**PRE
10A 125VAC, 6A 250VAC**



TYCO ELECTRONICS LOGO
PER TEC-202-36

9 1-1634200-7 SHOWN ON-OFF-ON

THIS DRAWING IS A CONTROLLED DOCUMENT.		DWN SA008712 2-4-07	TE Connectivity	
DIMENSIONS: mm		CHK -	NAME POWER ROCKER SWITCH 19,4MM X 22,2mm PANEL SIZE DPST, NON-ILLUMINATED	
TOLERANCES UNLESS OTHERWISE SPECIFIED:		APVD -	SIZE A2	
0 PLC ± -		PRODUCT SPEC -	CAGE CODE 00779	DRAWING NO C=1634200
1 PLC ± -		APPLICATION SPEC -	RESTRICTED TO -	
2 PLC ± -		WEIGHT -	SCALE 3:1 SHEET 4 OF 7 REV H	
3 PLC ± -		MATERIAL -	CUSTOMER DRAWING	
4 PLC ± -		FINISH -		
ANGLES ± -				

REVISIONS					
P	LTR	DESCRIPTION	DATE	DWN	APVD
-	-	SEE SHEET 1	-	-	-

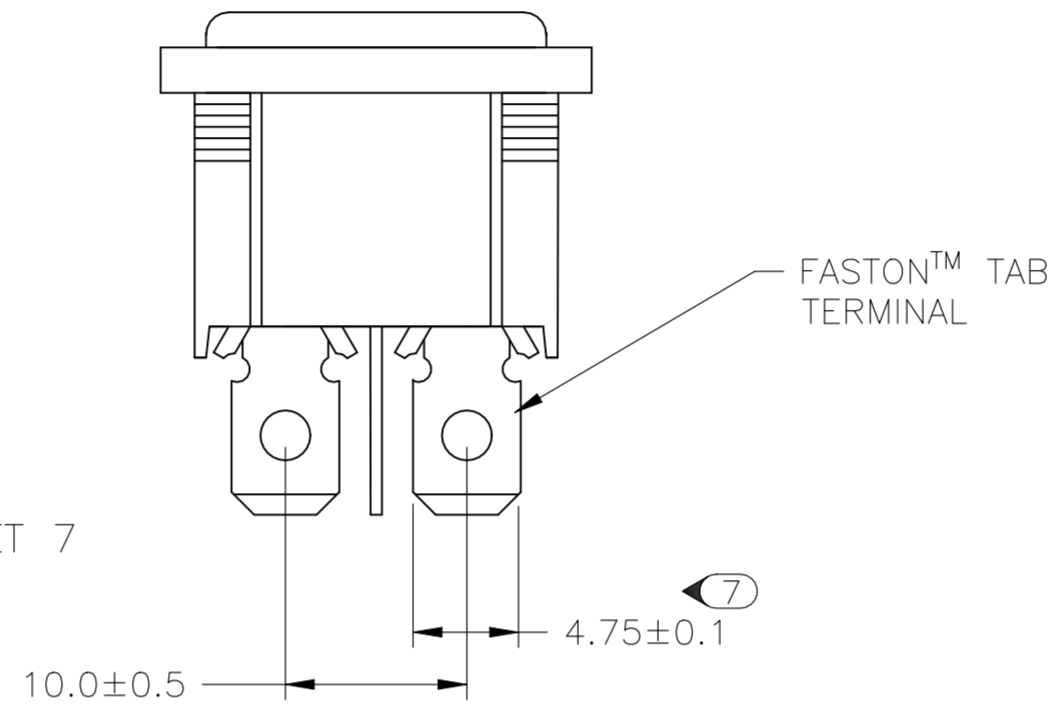
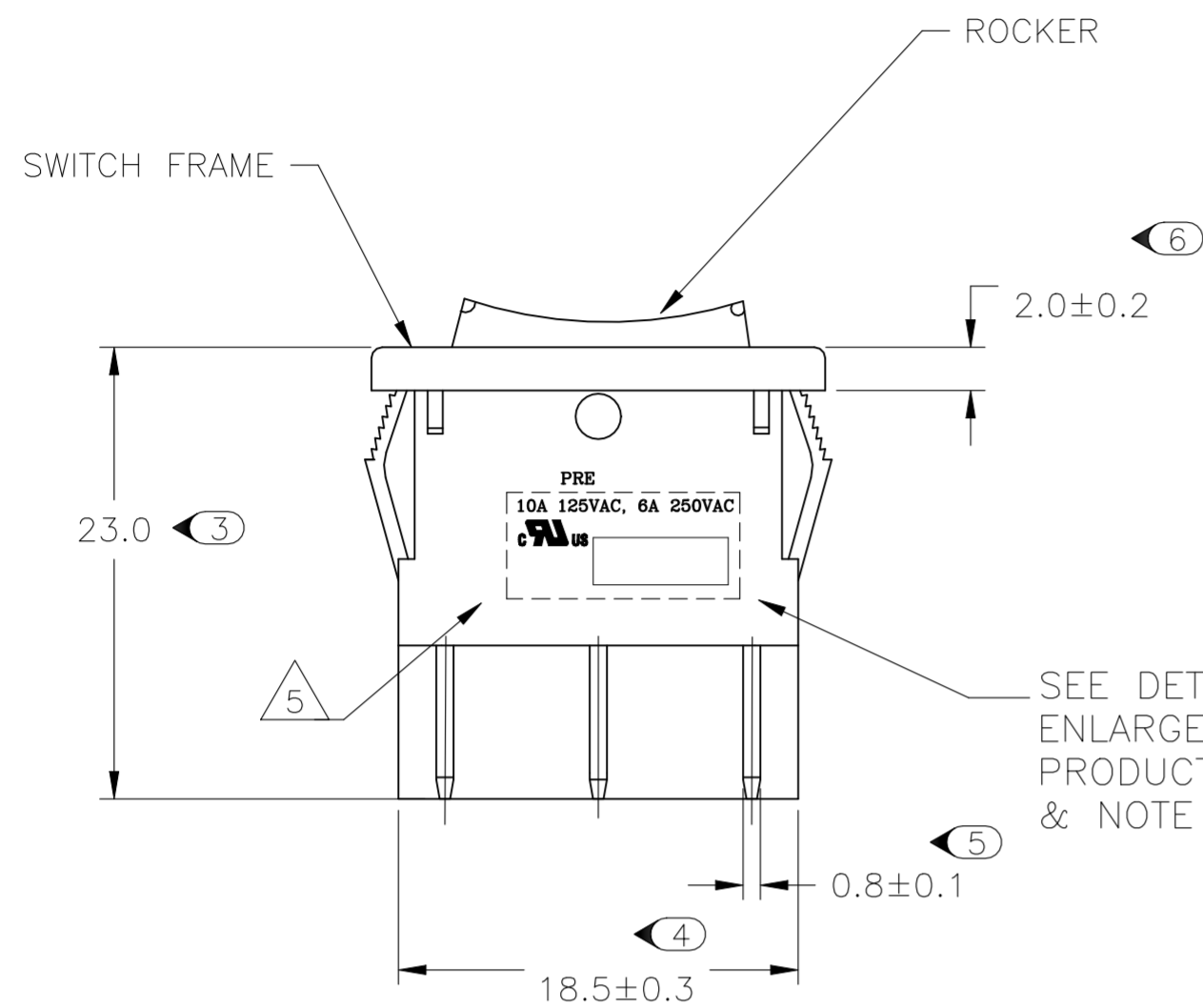

PANEL CUT OUT

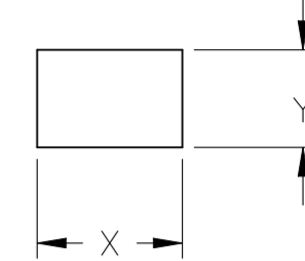

2.00-3.00	20.20	22.20
1.25-2.00	19.60	22.20
0.75-1.25	19.40	22.20
PANEL THICKNESS	X	Y

CIRCUIT DIAGRAM

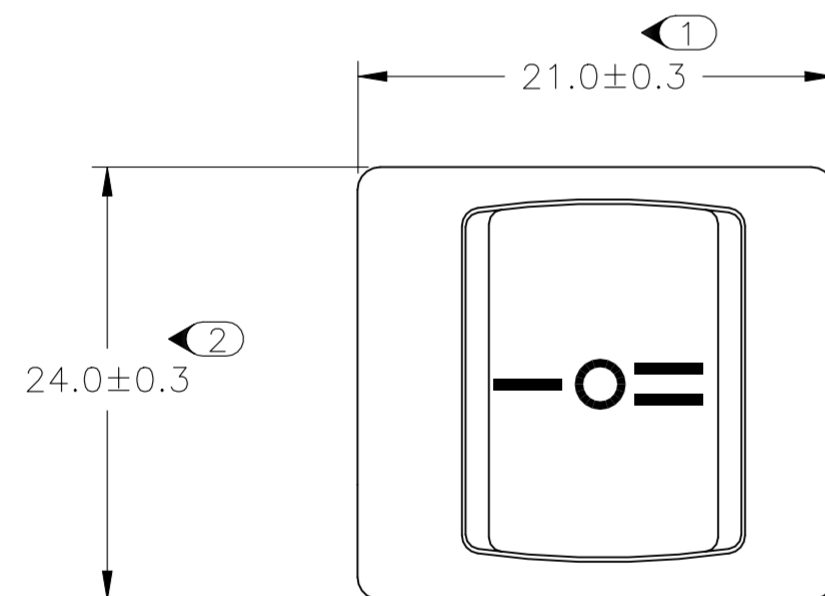
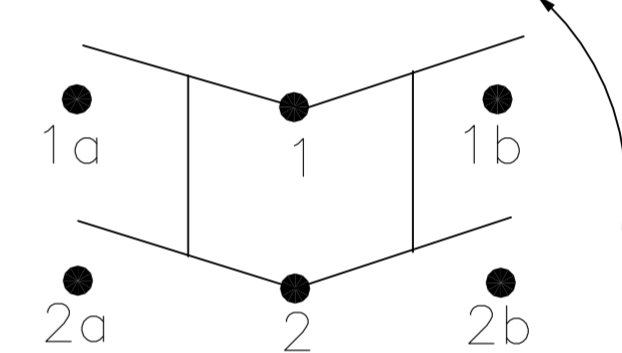

SEE DETAIL A FOR ENLARGED VIEW OF PRODUCT MARKINGS & NOTE 5 ON SHEET 7

**PRODUCT MARKING
DETAIL A**

**PRE
10A 125VAC, 6A 250VAC**



TYCO ELECTRONICS LOGO
PER TEC-202-36

10 2-1634200-3 SHOWN ON-OFF-(ON)

THIS DRAWING IS A CONTROLLED DOCUMENT.		DWN SA008712 2-4-07	TE Connectivity	
DIMENSIONS: mm		CHK -	NAME	
TOLERANCES UNLESS OTHERWISE SPECIFIED:		APVD -	POWER ROCKER SWITCH 19,4MM X 22,2mm	
0 PLC ± -	1 PLC ± -	PRODUCT SPEC -	PANEL SIZE DPST, NON-ILLUMINATED	
2 PLC ± -	3 PLC ± -	APPLICATION SPEC -	SIZE A2	RESTRICTED TO -
4 PLC ± -	ANGLES ± -	WEIGHT	CAGE CODE 00779	DRAWING NO C=1634200
MATERIAL -	FINISH -	CUSTOMER DRAWING	SCALE 3:1	SHEET 5 OF 7
			REV G	

REVISIONS					
P	LTR	DESCRIPTION	DATE	DWN	APVD
-	-	SEE SHEET 1	-	-	-

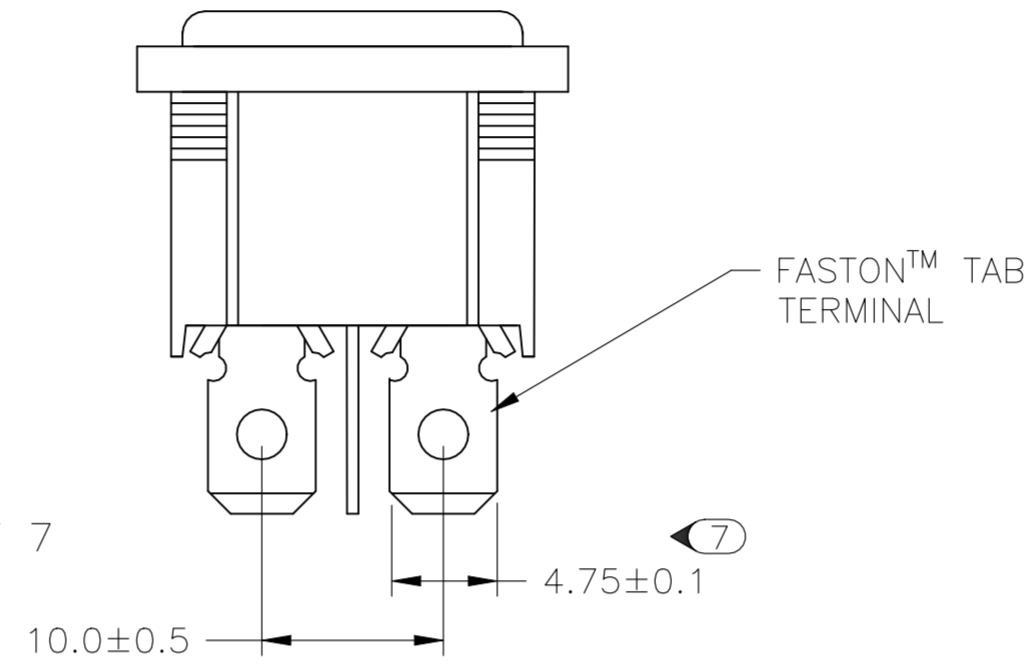
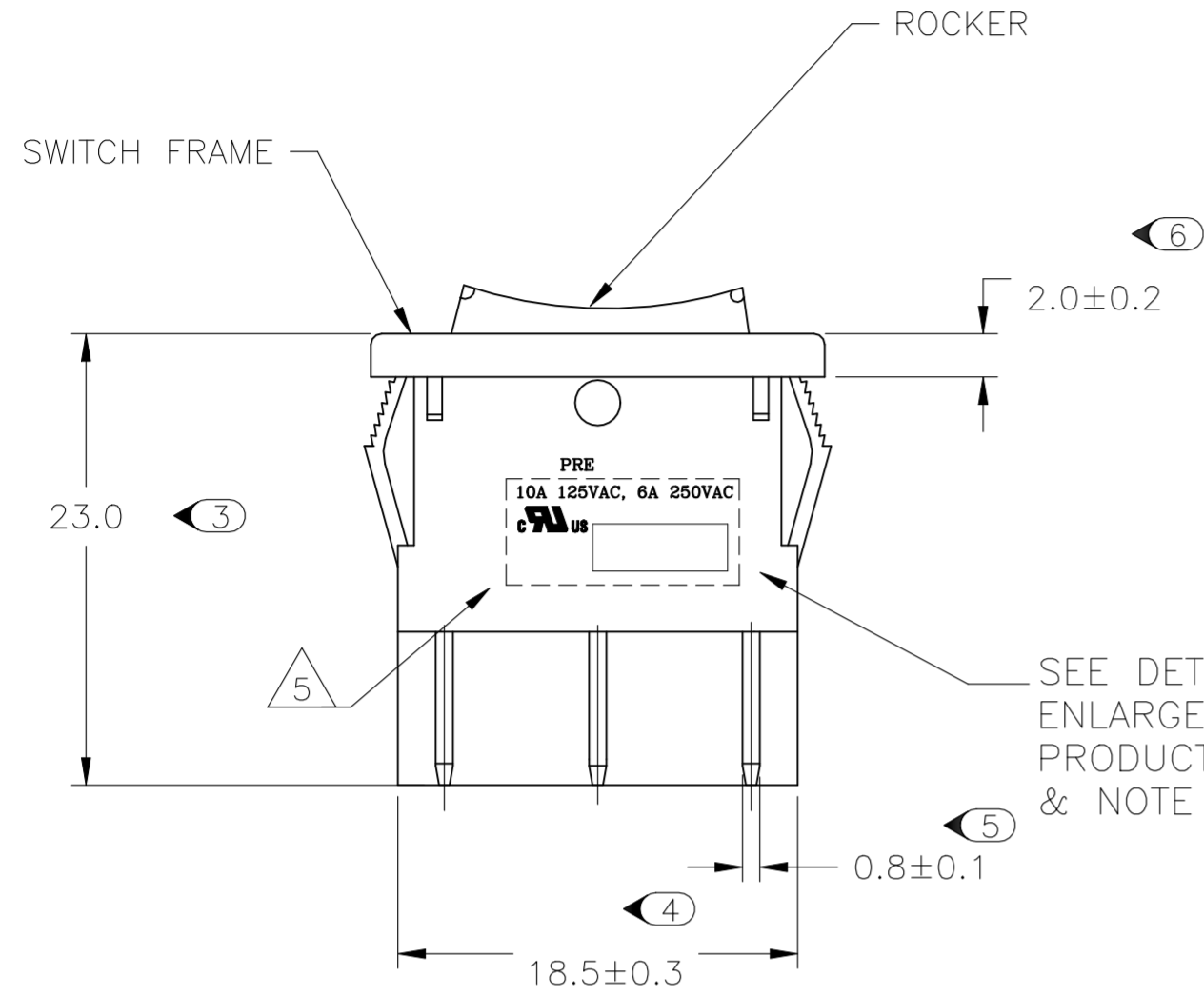

PANEL CUT OUT

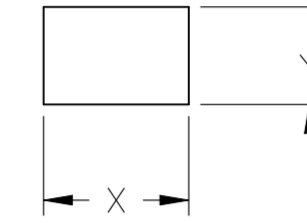

2.00-3.00	20.20	22.20
1.25-2.00	19.60	22.20
0.75-1.25	19.40	22.20
PANEL THICKNESS	X	Y

SEE DETAIL A FOR ENLARGED VIEW OF PRODUCT MARKINGS & NOTE 5 ON SHEET 7

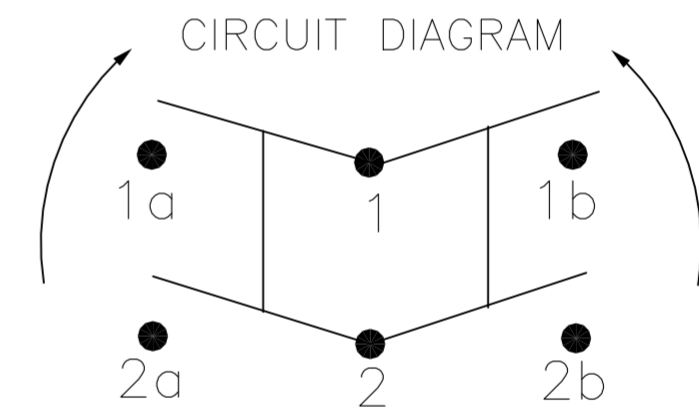
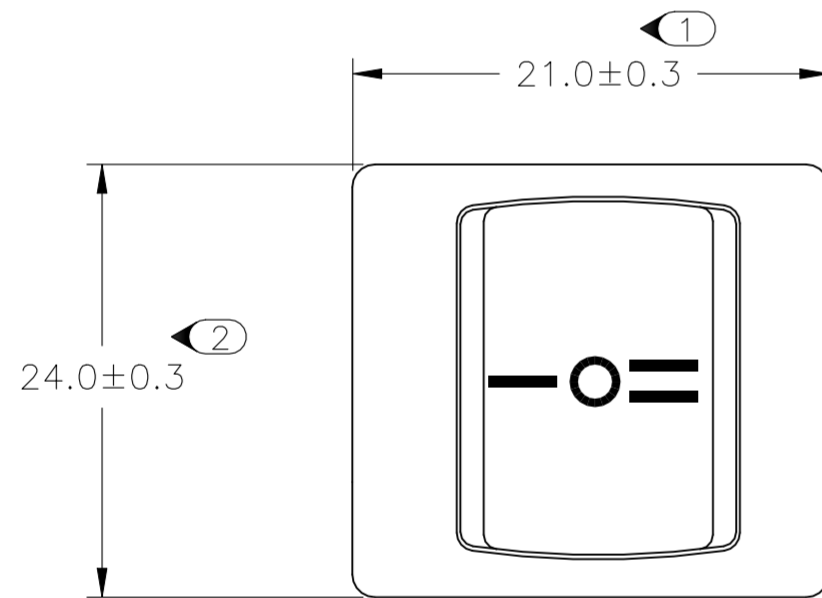

**PRODUCT MARKING
DETAIL A**

**PRE
10A 125VAC, 6A 250VAC**



TYCO ELECTRONICS LOGO
PER TEC-202-36

11 2-1634200-6 SHOWN (ON)-OFF-(ON)

THIS DRAWING IS A CONTROLLED DOCUMENT.		DWN SA008712 2-4-07	TE Connectivity	
DIMENSIONS: mm		CHK -	NAME POWER ROCKER SWITCH 19,4MM X 22,2mm PANEL SIZE DPST, NON-ILLUMINATED	
TOLERANCES UNLESS OTHERWISE SPECIFIED:		APVD -	PRODUCT SPEC -	
0 PLC ± -		PRODUCT SPEC -	APPLICATION SPEC -	
1 PLC ± -		APVD -	SCALE 3:1	
2 PLC ± -		APVD -	SHEET 6 OF 7	
3 PLC ± -		APVD -	REV G	
4 PLC ± -		APVD -	RESTRICTED TO -	
ANGLES ± -		APVD -	DRAWING NO. A2 00779 C=1634200	
FINISH -		APVD -	CAGE CODE 00779	
MATERIAL -		APVD -	WEIGHT -	
		APVD -	CUSTOMER DRAWING	

REVISIONS				
P	LTR	DESCRIPTION	DATE	APVD
-	-	SEE SHEET 1	-	-

ALCOSWITCH PART NUMBER

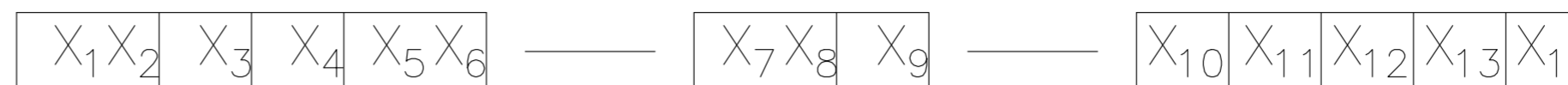

1 MATERIALS:
 HOUSING FRAME: NYLON 66.
 ACTUATOR: NYLON 66/ PC(ILLUMINATED)
 TERMINALS C1100R-1/2H WITH SILVER PLATED CONTACTS
 AgALLOY

2 FINISH:
 TERMINAL, ACTIVE CONTACTOR: 1.0µm [.000039] SILVER
 PLUNGER: 3.0µm[.000118] NICKEL

3 ELECTRICAL SPECIFICATIONS:
 CONTACT RESISTANCE : 50m ohm Max
 DIELECTRIC STRENGTH : AC 1500V, 1 MINUTE
 OPERATION TEMPERATURE: -20°C~85°C
 INSULATION R: DC 500V 100M ohm MIN

4 CURRENT AND VOLTAGE 10A@125VAC/6A@250VAC

5 ELECTRICAL RATINGS, APPROVED AGENCY LOGOS,
 TE LOGO PER TEC-202-36 APPROXIMATELY AS SHOWN
 AND PART NUMBER CAN APPEAR ON EITHER SIDE
 (FOR FULL DETAIL SEE INDIVIDUAL DRAWING)

6 ON-OFF, WITH OPAQUE, SINGLE-COLOR ROCKER BUTTON.

7 ON-OFF, WITH TRANSPARENT, LAMP-ILLUMINATED ROCKER
 BUTTON.

8 ON-ON, WITH OPAQUE, SINGLE-COLOR ROCKER BUTTON.

9 ON-OFF-ON, WITH OPAQUE, SINGLE-COLOR ROCKER BUTTON.

10 ON-OFF-(ON), WITH OPAQUE, SINGLE-COLOR ROCKER
 BUTTON.

11 (ON)-OFF-(ON), WITH OPAQUE, SINGLE-COLOR ROCKER
 BUTTON.

12 REFER TO QIP DIMENSIONAL REPORT

13 2002/95/EC/(RoHS) COMPLIANT

14 NOTE REMOVED.

SWITCH TYPE: X1 X2 = PR - POWER ROCKER

NOMINAL PANEL CUT OUT SIZE: X3 = E - 19.4X22.2 [.764x.874]

NUMBER OF POLES: X4 = D - DOUBLE

SWITCH FUNCTION: X5 X6 = A1 -
B1 -
D1 -
D3 -
D4 -
D5 -

CURRENT RATING: X7 X8 = OZ -

TERMINAL TYPE: X9 = E - FASTON™ TAB
L - SOLDER LUG

FRAME COLOR: X10 = B - BLACK
W - WHITE

ROCKER COLOR: X11 = B - BLACK
G - GREEN
R - RED
W - WHITE

SECONDARY ROCKER COLOR: X12 = Ø - NOT APPLICABLE

B - BLACK
G - GREEN
R - RED
W - WHITE

LEGEND TEXT PATTERN: X13 =

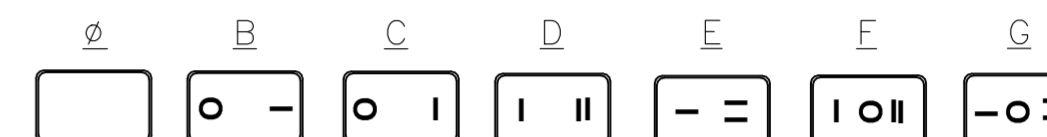

LEGEND TEXT COLOR: X14 = Ø - NOT APPLICABLE

G - GREEN
R - RED
B - BLACK
W - WHITE

	1	PREDA1-07F-BB000	1634200-1
	1	PREDA1-07F-BB0BW	1634200-2
	1	PREDA1-07F-BB0CW	1634200-3
	1	PREDA1-07L-BB000	1634200-4
	1	PREDA1-07L-BB0BW	1634200-5
	1	PREDA1-07L-BB0CW	1634200-6
OBSOLETE	2	PREDB1-07F-BR000	1634200-7
	2	PREDB1-07L-BR000	1634200-8
	2	PREDB1-07F-BG000	1634200-9
OBSOLETE	2	PREDB1-07L-BG000	1-1634200-0
	3	PREDD1-07F-BB000	1-1634200-1
	3	PREDD1-07F-BB0DW	1-1634200-2
	3	PREDD1-07F-BB0EW	1-1634200-3
OBSOLETE	3	PREDD1-07L-BB000	1-1634200-4
	3	PREDD1-07L-BB0DW	1-1634200-5
	3	PREDD1-07L-BB0EW	1-1634200-6
	4	PREDD3-07F-BB0FW	1-1634200-7
	4	PREDD3-07F-BB0GW	1-1634200-8
OBSOLETE	4	PREDD3-07L-BB0FW	1-1634200-9
	4	PREDD3-07L-BB0GW	2-1634200-0
	5	PREDD4-07F-BB000	2-1634200-1
	5	PREDD4-07F-BB0FW	2-1634200-2
	5	PREDD4-07F-BB0GW	2-1634200-3
OBSOLETE	6	PREDD5-07F-BB000	2-1634200-4
	6	PREDD5-07F-BB0FW	2-1634200-5
	6	PREDD5-07F-BB0GW	2-1634200-6
	SHEET REF	ALCOSWITCH PART NUMBER.	TE PART NUMBER.

THIS DRAWING IS A CONTROLLED DOCUMENT.		DWN SA008712 2-4-07		
DIMENSIONS: mm		CHK -		
TOLERANCES UNLESS OTHERWISE SPECIFIED:		APVD -	NAME	
0 PLC ± -		PRODUCT SPEC -	POWER ROCKER SWITCH 19,4MM X 22,2mm	
1 PLC ± -		APPLICATION SPEC -	PANEL SIZE DPST, NON-ILLUMINATED	
2 PLC ± -		WEIGHT	SIZE A2	CAGE CODE 00779
3 PLC ± -		FINISH -	DRAWING NO C=1634200	RESTRICTED TO -
4 PLC ± -		MATERIAL -	SCALE 3:1	SHEET 7 OF 7
ANGLES ± -		CUSTOMER DRAWING	REV G	