

used for: D-SUB

POS.	A ^{-0.76}	B ^{+0.25}	C	D ^{-0.3}	PART-NO.
9	31.19	16.79	25.00 ^{+0.12} _{-0.13}	6.12	163A11469X
15	39.52	25.12	33.30 ^{+0.15} _{-0.1}	6.12	163A11479X
25	53.42	38.84	47.04 ^{+0.13}	5.99	163A11489X
37	69.70	55.30	63.50 ^{+0.13}	5.99	163A11499X

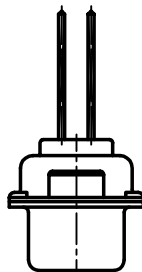
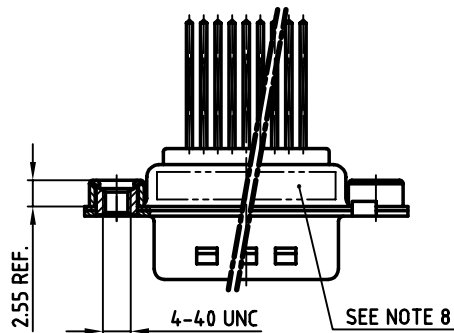
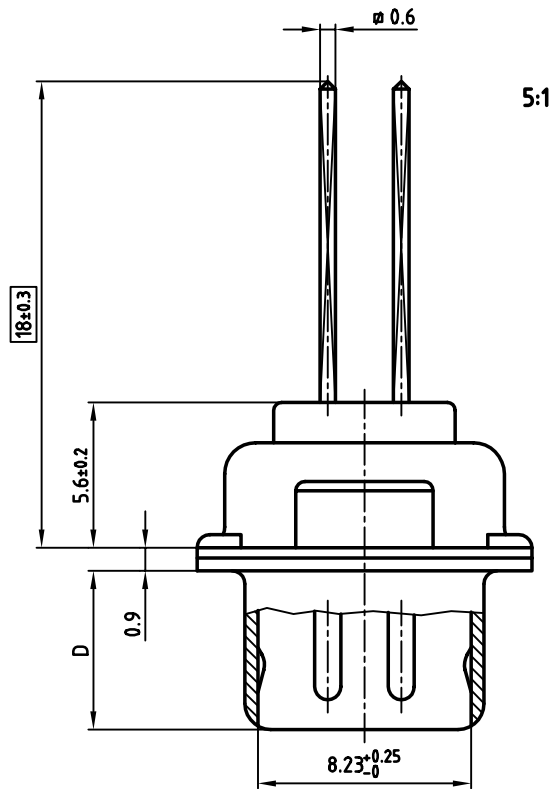
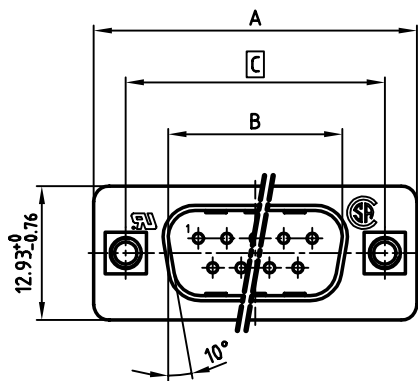

NOTES:

- METALSHELLS: STEEL; min. 320µ" TIN
- INSULATORS: PBT GF UL 94 V-0, BLACK
- CONTACTS: COPPER ALLOY
PLATING: min. 8µ" HARD GOLD OVER min. 50µ" NICKEL
- THREADED INSERT: COPPER ALLOY; min. 200µ" TIN over 80µ" NICKEL
- COLLAR: COPPER ALLOY; min. 200µ" TIN over 80µ" NICKEL
- P.C.B. HOLE DRILLINGS ON DRAWING NO.: 16K111UA
- MAXIMUM TORQUE VALUE FOR THREAD: 6" LBS
- CONNECTOR IS PART MARKED: PART-NO. CONEC Y/WW
- = CRITICAL DIMENSION

Directive 2002/95/EC
"RoHS"
Compliant

APPROVAL * FREIGABE * DEBLOCAGE * AUTORIZACION * APPROVAL	
CUSTOMER APPROVAL DATE:	
NAME:	TITLE:
COMPANY NAME:	
APPROVAL * FREIGABE * DEBLOCAGE * AUTORIZACION * APPROVAL	

THIS DRAWING MAY NOT BE COPIED OR REPRODUCED IN ANY WAY, AND MAY NOT BE PASSED ON TO A THIRD PARTY, WITHOUT WRITTEN PERMISSION. OWNERSHIP AND COPYRIGHT OF CONEC GmbH DO NOT ALTER CAD DRAWING BY HAND

rev.	description	date	name

tolerance	dim. in mm	scale: 2:1 (5:1)
material: SEE NOTES		title: D-SUB MALE 9-37pos. WIRE WRAP with threaded insert
2002 date	name	dwg no: AutoCAD 2000
drawn 15.11.	Parei	DIN-A
appd. 18.11.	Kühle	3
norm DIN 41652		sh: 1/1
d-old		
CONEC		part no: SEE TABLE