

rev	ecn no	dr	date
A	V20428	LRJ	2002-03-11
B	V03-0427	TAB	2003-14-15
C	V03-0663	TAB	2003-06-12
D	V05-0052	VS	2005-10-14
E	V06-0558	LP	2006-06-12
F	V07-0438	LP	2007-07-02
G	V08-0329	SM	2008-11-14

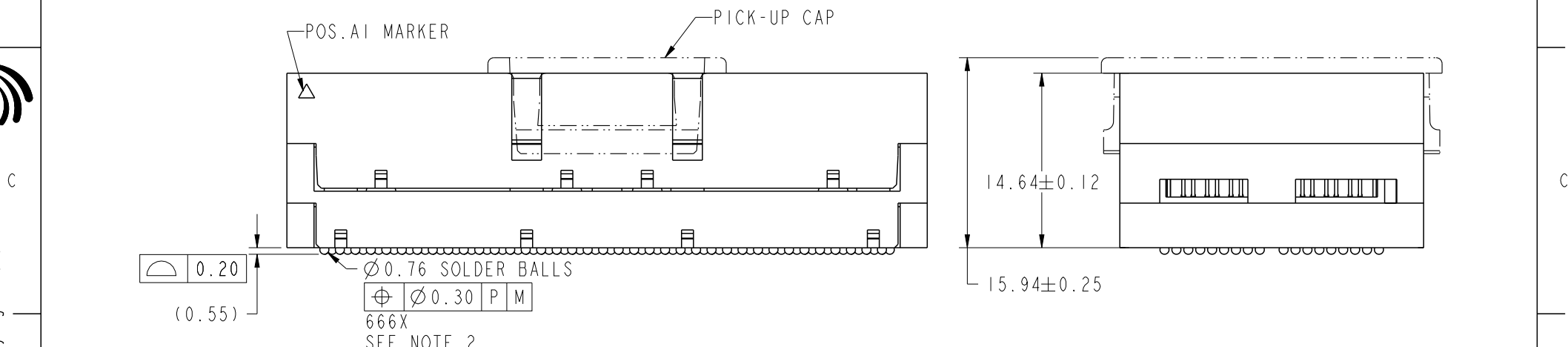
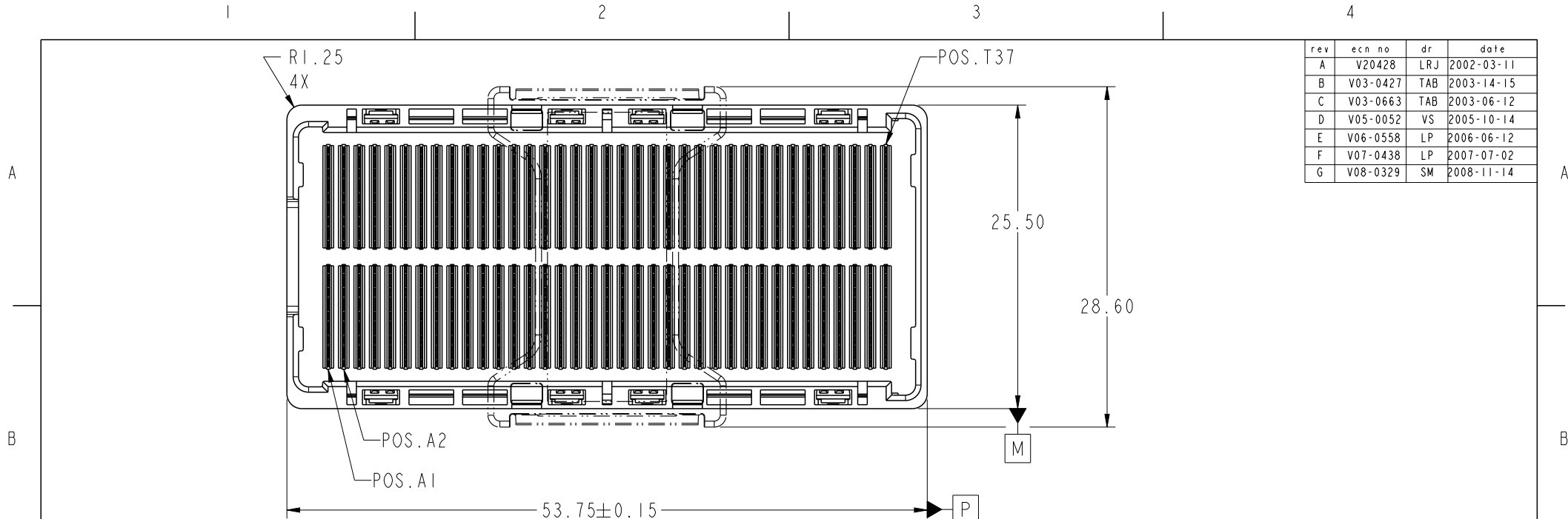

spec ref	-	dr	Bill Lin	2010/02/02	projection 	mm 	size	A4	scale	1:10	
tolerance std	ASME Y14.5	eng	Nickor Zuo	2011/06/02			ecn no	ELX-DG-003943-1			
surface	✓	chr	Alex Cao	2011/06/24			product family	GIG-Array		rel level	Released
		appr	Pei-Ming Zheng	2011/06/27	product family		GIG-Array		rel level	Released	
				title GIG-Array 15mm PLUG ASSY. 296 SIG. POS.		dwg no 55700		rev H			
		www.fci.com		cat. no.		Product - Customer Drw		sheet 1 of 5			

KEY ORIENTATION SILKSCREEN  
(OPTIONAL)

④ CONTACTS IN  
ROWS J & K ARE  
TIED TOGETHER  
(COMMONED)

SEE NOTES 4 & 5

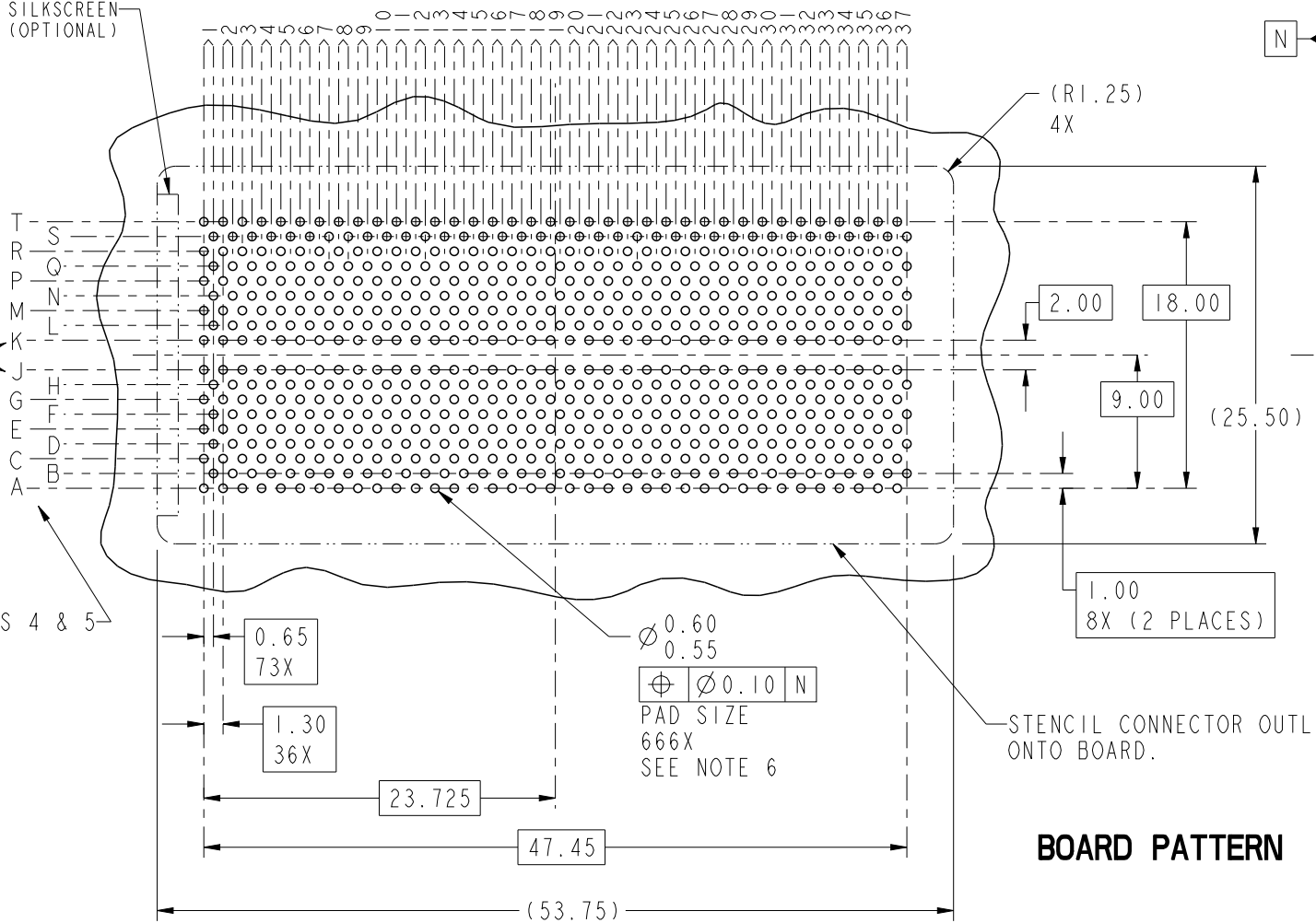

**BOARD PATTERN**

spec ref	-	dr	Bill Lin	2010/02/02	projection	mm	size	A4	scale	1:10			
tolerance std	ASME Y14.5	eng	Nickor Zuo	2011/06/02			ecn no		ELX-DG-003943-1				
TOLERANCES UNLESS OTHERWISE SPECIFIED		chr	Alex Cao	2011/06/24			product family		GIG-Array		rel level		Released
surface	✓	appr	Pei-Ming Zheng	2011/06/27	title		GIG-Array		dwg no		55700	rev	H
	linear				www.fci.com		cat. no.		Product - Customer Drw		sheet 2 of 5		
	angular												

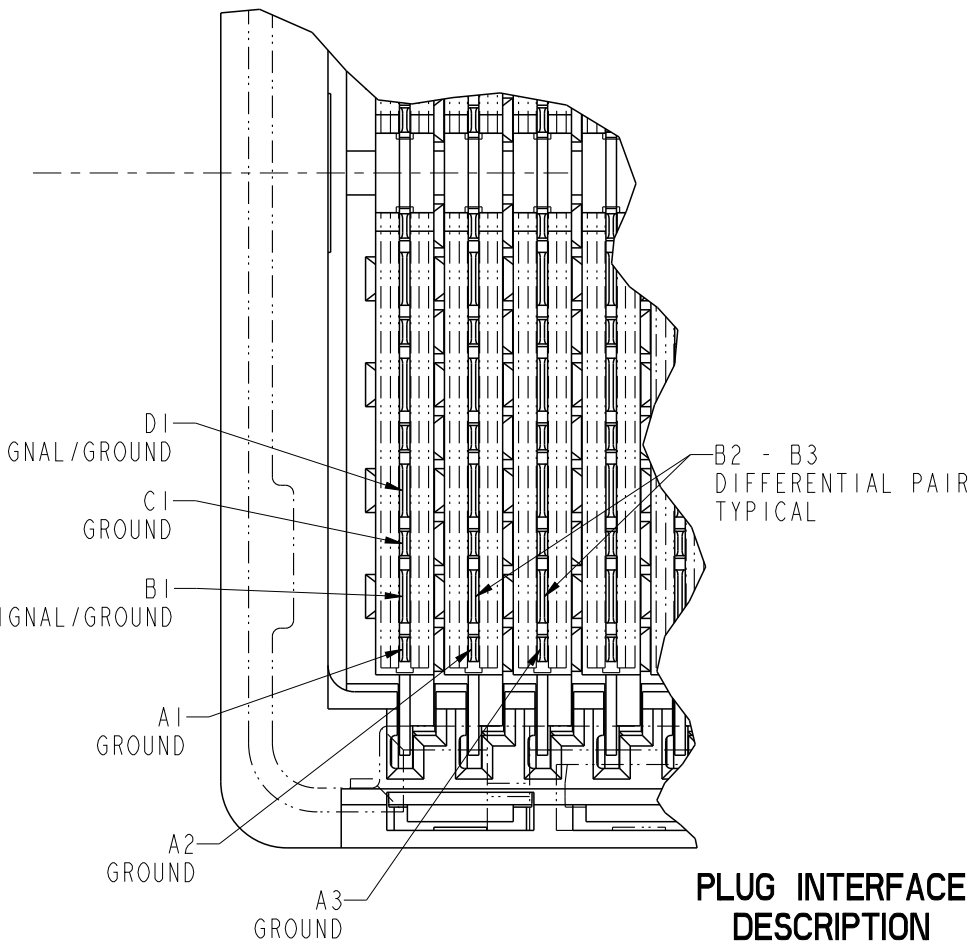

**PLUG INTERFACE DESCRIPTION**

SCALE 7:1



Copyright FCI.

spec ref		-		dr	Bill Lin	2010/02/02	projection 	mm 	size	A4	scale	37:5	
tolerance std	ASME Y14.5	TOLERANCES UNLESS OTHERWISE SPECIFIED				eng			Nickor Zuo	2011/06/02	ecn no	ELX-DG-003943-1	
						chr			Alex Cao	2011/06/24		product family	GIG-Array
surface	✓	linear	0.X	±0.30	 <b>www.fci.com</b>	title			dwg no	55700	rev		H
			0.XX	±0.10		GIG-Array							
			0.XXX	±0.05		15mm PLUG ASSY. 296 SIG. POS.							
		angular	0°	±2°	cat. no.	Product - Customer Drw				sheet 3 of 5			

ProE File - REV C - 2009-06-09

**FLAT AREA PICK-UP CAP**

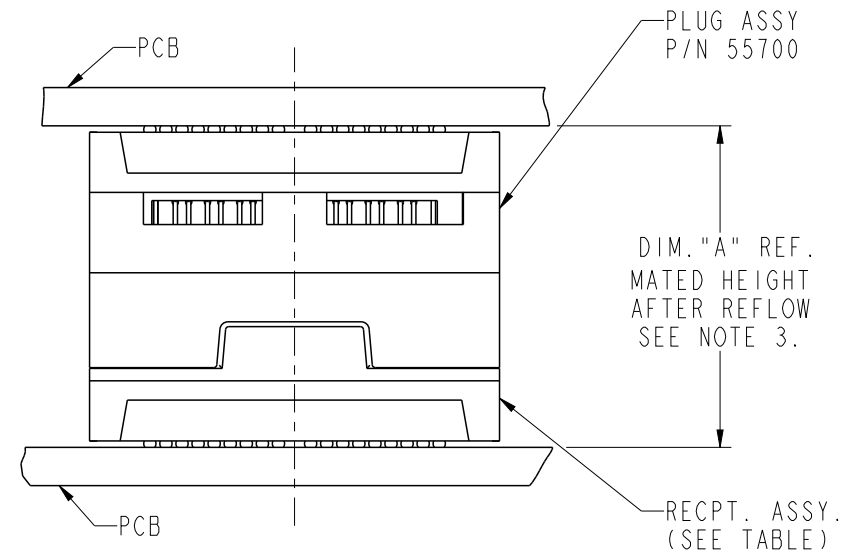
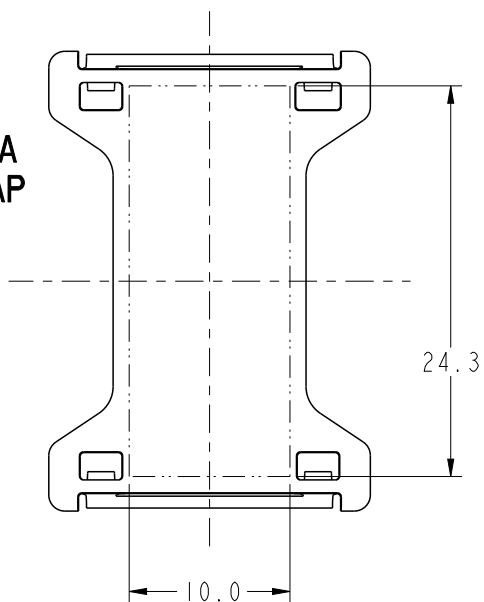

**END VIEW OF MATED CONNECTORS**

DIM. "A"	RECPT. ASSY. P/N
20	55701
30	55733



Copyright FCI.

spec ref		-		dr	Bill Lin	2010/02/02	projection 	mm 	size	A4	scale	1:10			
tolerance std	ASME Y14.5	TOLERANCES UNLESS OTHERWISE SPECIFIED		eng	Nickor Zuo	2011/06/02			ecn no	ELX-DG-003943-1					
				chr	Alex Cao	2011/06/24				rel level	Released				
surface	✓	linear	0.X	±0.30	FCI 	title	GIG-Array	dwg no	55700	rev	H				
			0.XX	±0.10								www.fci.com	cat. no.	Product - Customer Drw	sheet 4 of 5
			0.XXX	±0.05											
		angular	0°	±2°											

PRODUCT NUMBER	SOLDER BALL COMPOSITION	CONTACT PLATING PERFORMANCE LEVEL
55700-001	STANDARD (EUTECTIC)	PERFORMANCE-BASED PLATING, QUALIFIED TO MEET THE REQUIREMENTS OF FCI PRODUCT SPECIFICATION GS-12-192, INCLUDING TELCORDIA CENTRAL OFFICE
55700-001LF	LEADFREE	
55700-201	STANDARD (EUTECTIC)	Au over Ni
55700-201LF	LEADFREE	

NOTES:

- ① MATERIAL:  
HOUSING: LCP  
CONTACT: COPPER ALLOY  
PLATING (CONTACT): Au OVER Ni.  
UL RATING: 94 V-0  
SOLDER BALL: (SEE TABLE) EUTECTIC SnPb OR LEADFREE 95.5 Sn/4Ag/0.5Cu
- ② SOLDER BALLS WILL NOT BE PERFECT SPHERICAL SHAPE DUE TO REFLOW ATTACHMENT.
- ③ MATED HEIGHT EFFECTED BY CUSTOMERS' PCB PAD SIZE, PLATING, SOLDER REFLOW PROFILE & SOLDER PASTE.
- ④ CONTACTS IN ROWS A,C,E,G,J,K,M,P,R AND T ARE SINGLE BEAM CONTACTS, TYPICALLY USED AS GROUND PINS. (NOTE: CONTACTS IN ROWS J & K ARE TIED TOGETHER [COMMONED])
- ⑤ CONTACTS IN ROWS B,D,F,H,L,N,Q AND S ARE DUAL BEAM CONTACTS, TYPICALLY USED AS SIGNAL PINS.

NOTES CONTINUED

- ⑥ SPECIFIED POSITIONAL TOLERANCE DEFINES PAD TO PAD LOCATION WITHIN LAND PATTERN. POSITIONAL TOLERANCE OF LAND PATTERN TO FUDICIAL MARKS OR PCB DATUMS SHALL BE DEFINED BY CUSTOMER. FOR RECOMMENDED PRODUCT APPLICATION AND PCB DESIGN DETAILS, SEE DOC. NO. GS-20-016.
- ⑦ FOR PROPER APPLICATION FOLLOW FCI APPLICATION SPECIFICATION GS-20-033 LEADFREE SOLDER BALLS WILL NOT SOLDER PROPERLY IN A LEADED SOLDER PROCESS DUE TO A HIGHER REFLOW TEMPERATURE, LEADFREE PRODUCT IS THEREFORE NOT BACKWARDS COMPATIBLE WITH LEADED OR SOME SOLDERING APPLICATIONS. REFERENCE FCI APPLICATION SPECIFICATION.
- ⑧ THIS PRODUCT MEETS THE EUROPEAN UNION DIRECTIVES AND OTHER COUNTRY REGULATIONS AS DESCRIBED IN GS-22-008. PRODUCT MEETING WITH THIS DIRECTIVE IS IDENTIFIED IN THE LOT CODE NUMBER MARKED ON EACH PART BY HAVING AN "X" IN THE SEVENTH CHARACTER POSITION.

spec ref	-	dr	Bill Lin	2010/02/02	projection	mm	size	A4	scale	1:10
tolerance std	TOLERANCES UNLESS OTHERWISE SPECIFIED	eng	Nickor Zuo	2011/06/02			ecn no	ELX-DG-003943-1		
ASME Y14.5		chr	Alex Cao	2011/06/24				product family	GIG-Array	rel level
-		appr	Pei-Ming Zheng	2011/06/27	title	GIG-Array		dwg no	55700	rev
surface	linear	0.X	±0.30		15mm PLUG ASSY. 296 SIG. POS.	www.fci.com	cat. no.	Product - Customer Drw	sheet 5 of 5	
-	angular	0.XX	±0.10							
		0.XXX	±0.05							
		0°	±2°							