

REVISIONS					
P	LTR	DESCRIPTION	DATE	DMN	APVD
A		REVISED PER ECO-16-010367	14JUL2016	DS	SY

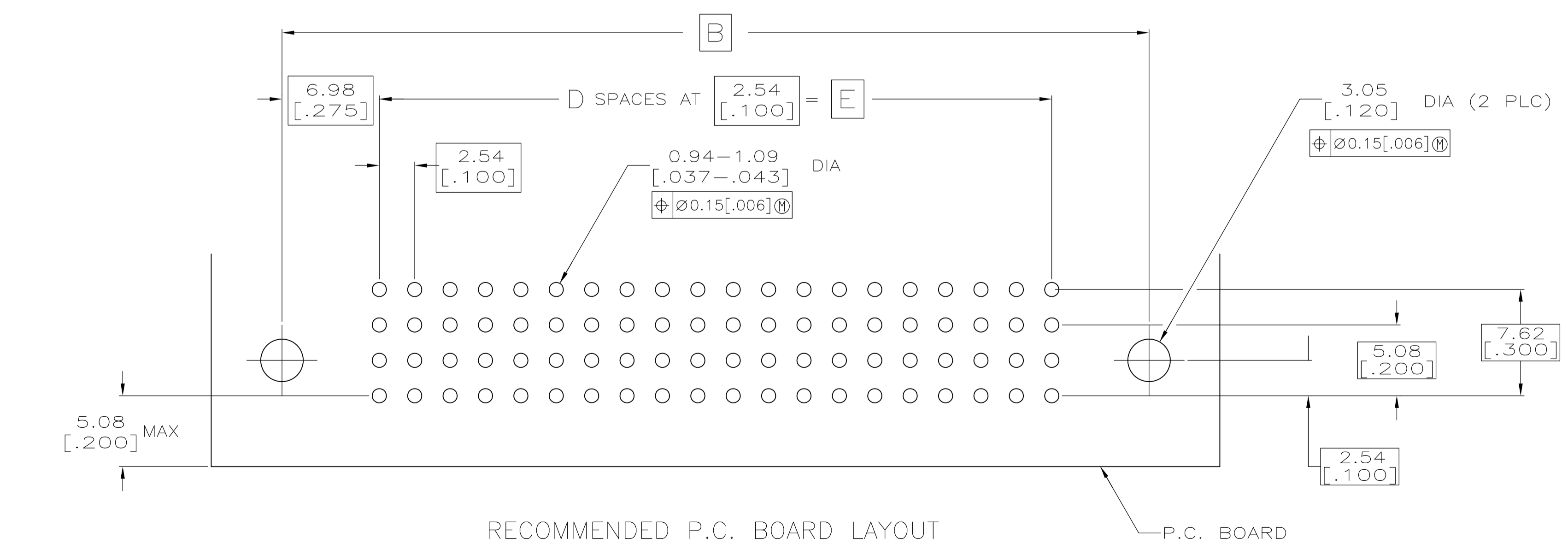

- 1 HOUSING MATERIAL: THERMOPLASTIC.
- 2 CONTACT MATERIAL: COPPER ALLOY.
- 3 FINISH:
MATING AREA: MEETS THE PERFORMANCE REQUIREMENTS OF PRODUCT SPECIFICATION 108-9063; BASED ON TELCORDIA DR-1217-CORE APPLICATIONS IN UNCONTROLLED ENVIRONMENTS.
SOLDER TAILS AREA: TIN PLATED.
- 4 SOLDER TAILS MUST FIT HOLE PATTERN AS SHOWN ON THE RECOMMENDED P.C. BOARD LAYOUT.
- 5 QUANTITIES OF VOID CORING ARE DEPENDENT ON THE POSITION SIZE OF THE HOUSING.
- 6 HOUSINGS WITH CENTER MOUNTING ARE RECOMMENDED FOR ASSEMBLIES HAVING 75 CONTACTS OR MORE PER ROW.
- 7 OBSOLETE PARTS: OBSOLETE CIS STREAMLINING PER D.RENAUD/D.SINISI
- 8 CONTACT FINISH: .00127-.00254 [.000050-.000100] NICKEL UNDERPLATE ALL OVER, .000076 [.000030] GOLD PLATE IN CONTACT AREA, TIN PLATED SOLDER TAILS.

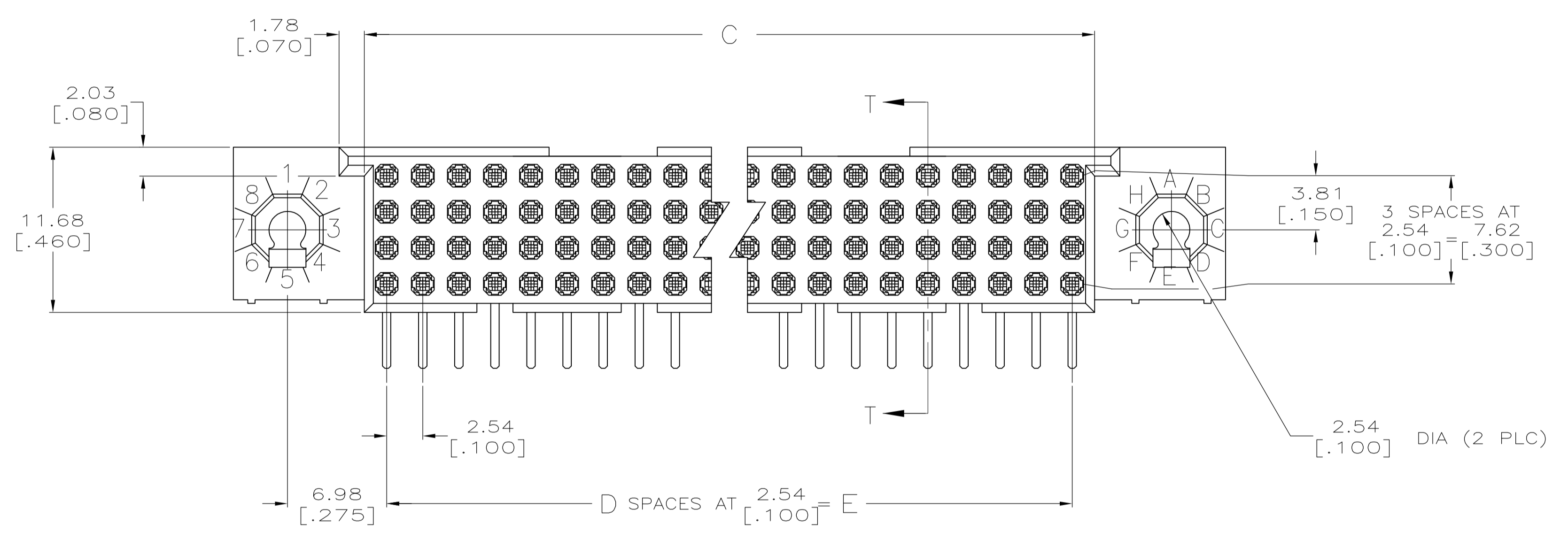
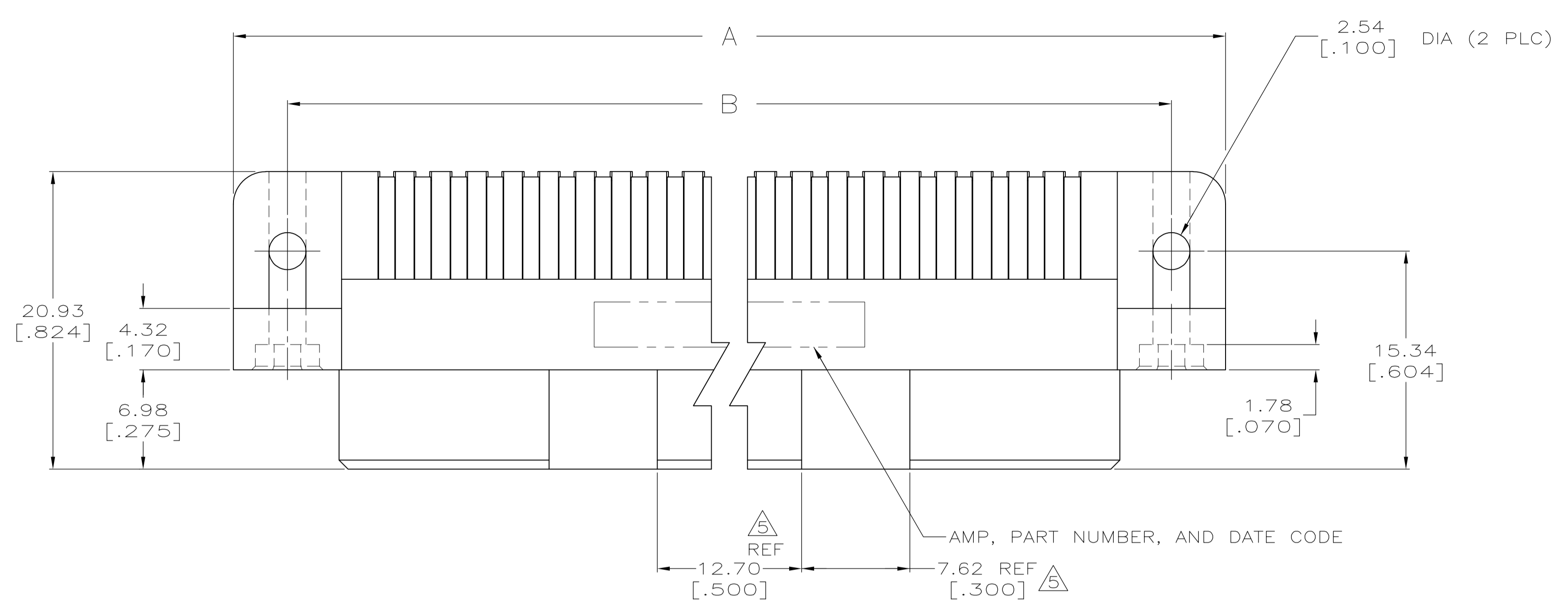
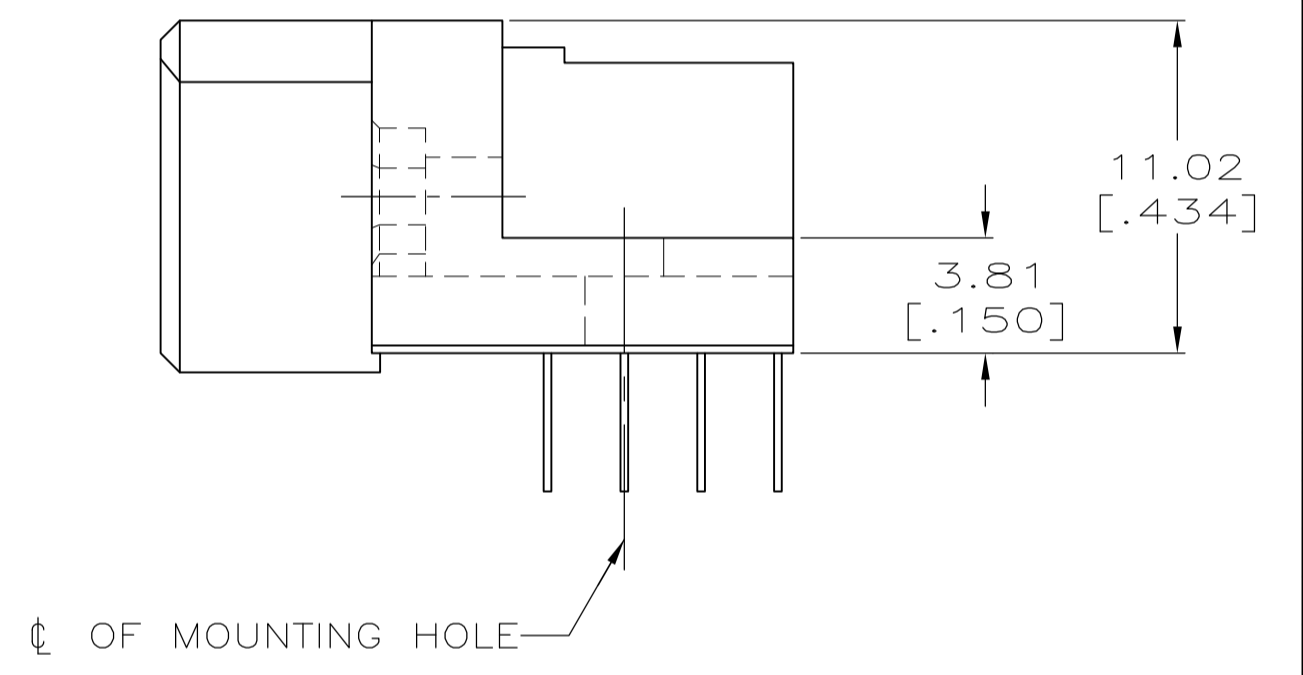
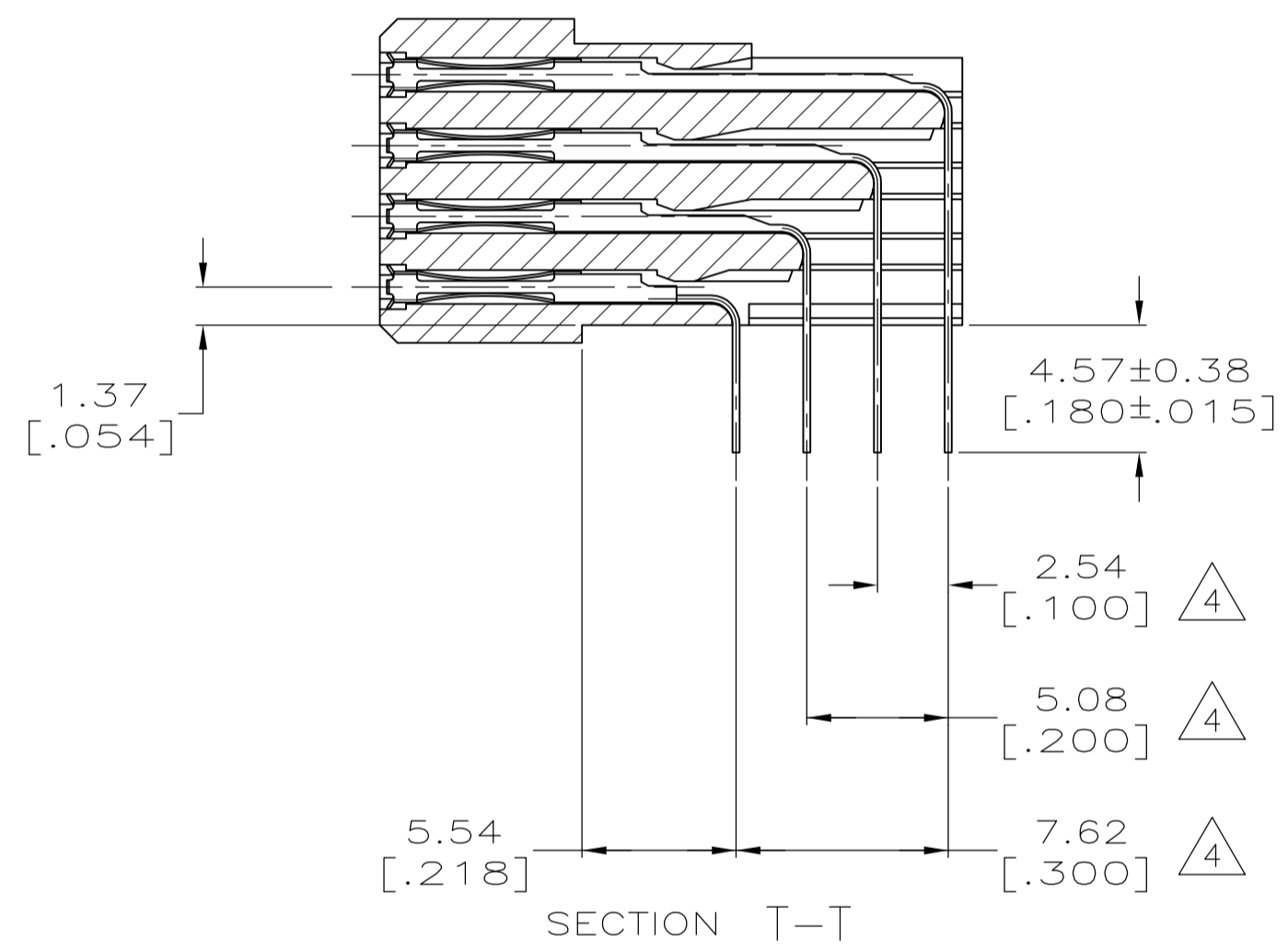

POSN	D	C	B	A	POSN	PART NUMBER
74	191.11 [7.524]	201.93 [7.950]	209.55 [8.250]	300	1-5532434-2	
69	175.26 [6.900]	178.41 [7.024]	189.23 [7.450]	280	1-5532434-1	
59	149.86 [5.900]	153.01 [6.024]	163.83 [6.450]	240	5532434-9	
54	137.16 [5.400]	140.31 [5.524]	151.13 [6.250]	220	5532434-8	
49	124.46 [4.900]	127.61 [5.024]	138.43 [5.450]	200	5532434-7	
44	111.76 [4.400]	114.91 [4.524]	125.73 [4.950]	180	5532434-6	
39	99.06 [3.900]	102.21 [4.024]	113.03 [4.450]	160	5532434-5	
34	86.36 [3.400]	89.51 [3.524]	100.33 [3.950]	140	5532434-4	
24	60.96 [2.400]	64.11 [2.524]	74.93 [2.950]	100	5532434-1	

THIS DRAWING IS A CONTROLLED DOCUMENT.

DIMENSIONS: mm [INCHES]

TOLERANCES UNLESS OTHERWISE SPECIFIED:

0 PLC	± .01
1 PLC	± .015
2 PLC	± .02
3 PLC	± .03
4 PLC	± .05
ANGLES	± .1

MATERIAL: 1 2

FINISH: 3

THIS DRAWING IS A CONTROLLED DOCUMENT. DIN J. POLIGNONE 10JUN05

CHK: A. SHARPE 10JUN05

APVD: A. SHARPE 10JUN05

NAME: ASSY, REC, RIGHT ANGLE, HDI LEAD FREE, 4 ROW, W/O GUIDES 4.57[.180] SOLDER POSTS

SIZE: A1

WEIGHT: 0.000000

CAGE CODE: 00779

DRAWING NO: 5532434

CUSTOMER DRAWING

SCALE: 4:1

SHEET: 1 of 1

REV: A