



Features

- Six Input Comparators with Schmitt-trigger Characteristics
- Input Clamping Current Capability of ± 10 mA
- Integrated Protection Cells (EMC, ESD, RF) Dedicated to All Input Stages
- Common Shutdown by Junction-temperature Monitor
- Reset with Hysteresis at Low Voltage
- ESD Protection According to Human Body Model: ± 2000 V (C = 100 pF, R = 1.5 k Ω)
- Output Stages:
 - Short-circuit Protected
 - Load-dump Protected at 1 k Ω
 - No Crosstalk on Adjacent Channels
 - Jump Start Possible



Hex Driver IC with Thermal Monitoring

U6805B

1. Description

The hex driver IC U6805B includes 6 non-inverted and current-limited output stages with an open collector. Common thermal shutdown protects outputs against critical junction temperature.

Each output can sink a current of 20 mA, and parallel output operation is possible. The digital inputs have Schmitt-trigger function with pull-up resistors of up to 5V.

Figure 1-1. Block Diagram

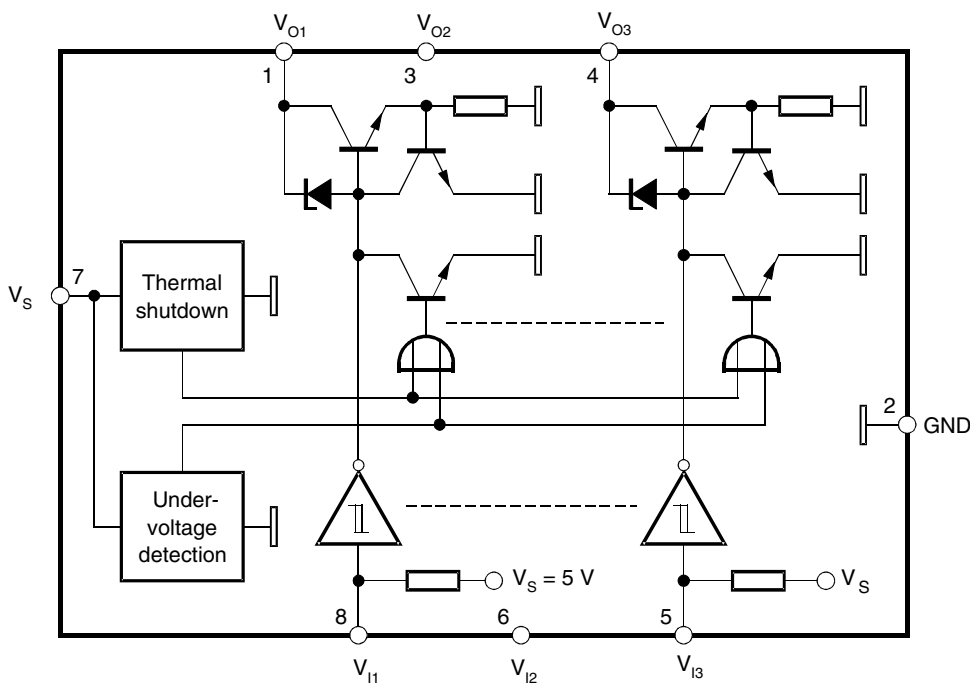

2. Pin Configuration

Figure 2-1. Pinning SO14

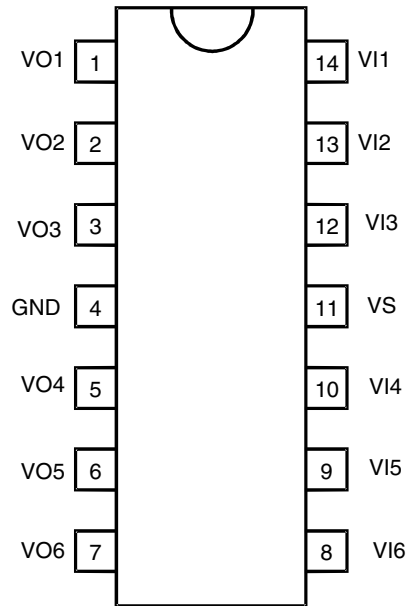

Table 2-1. Pin Description

Pin	Symbol	Function
1	VO1	Output 1
2	VO2	Output 2
3	VO3	Output 3
4	GND	Ground
5	VO4	Output 4
6	VO5	Output 5
7	VO6	Output 6
8	VI6	Input 6
9	VI5	Input 5
10	VI4	Input 4
11	VS	Supply voltage, 5V
12	VI3	Input 3
13	VI2	Input 2
14	VI1	Input 1

3. Basic Circuitry

The integrated circuit U6805B requires a stabilized supply voltage ($V_S = 5V \pm 5\%$) to comply with its electrical characteristics. An external buffer capacitor of $C = 100 \text{ nF}$ is recommended. An integrated 14V Z diode between V_S and ground protects the supply pin.

All input stages are provided with an integrated 250 k Ω pull-up resistor and can be directly connected to a microcontroller.

All output stages are open collectors, each capable of sinking 20 mA. Recommended external components:

Pull-up resistor, $R = 1 \text{ k}\Omega$

Capacitor to GND, $C = 470 \text{ pF}$, see [Figure 4-1 on page 4](#)

4. Functional Description

4.1 General

ON state: Low level at the input stage activates the corresponding output stage.

OFF state: The internal pull-up resistor provides high level to the input comparator and deactivates the output stage.

7V Zener diodes between each input pin and GND are capable of $\pm 10 \text{ mA}$ clamping current without crosstalk on adjacent input stages.

A total clamping current of $\pm 30 \text{ mA}$ should be observed with respect to the power dissipation.

4.2 Current Limitation of the Output Stages and Overtemperature Shutdown

A temperature-dependent current limitation in the range of 25 to 100 mA protects the stages in case of a short-circuit. Additionally, the chip temperature is monitored. If $T_{\text{chip}} > 148^\circ\text{C}$, all outputs are disabled and automatically enabled with a hysteresis of $\Delta T_{\text{Chip}} > 5\text{K}$. Refer to the hex driver U6807B if the temperature shutdown feature is not required.

4.3 Transients and Load Dump

An integrated 28V Zener diode protects each output stage against transients and load dump (Schaffner pulses). With the help of an external 1 k Ω resistor, the output transistor is capable of handling the corresponding current which flows during each of these conditions. Apart from that, the outputs are short-circuit and overload protected.

4.4 Low-voltage Detection

When the supply voltage is switched on, a power-on reset pulse is generated internally which disables all output stages until a defined supply-voltage level is reached. The low-voltage detection is provided with a hysteresis of $V_{\text{hyst}} = 0.5\text{V}$ typically.

Figure 4-1. Application Schematic

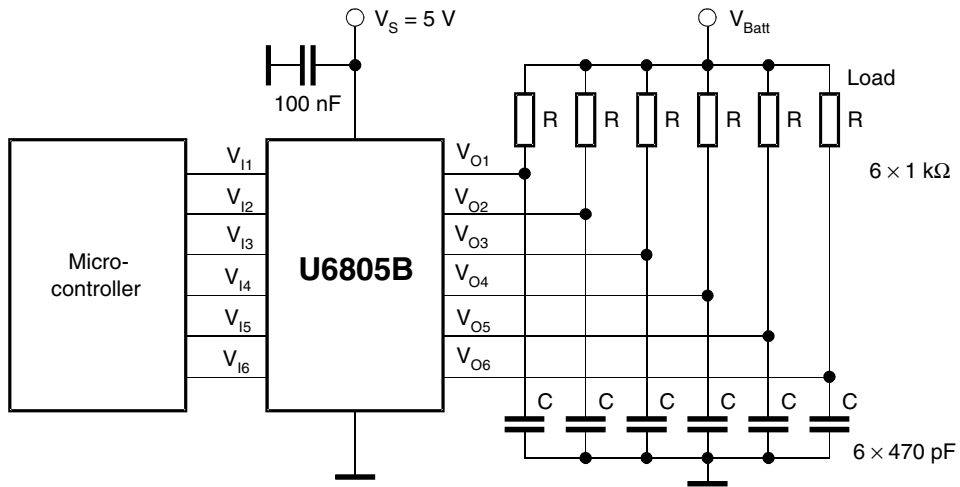

5. Absolute Maximum Ratings

Stresses beyond those listed under “Absolute Maximum Ratings” may cause permanent damage to the device. This is a stress rating only and functional operation of the device at these or any other conditions beyond those indicated in the operational sections of this specification is not implied. Exposure to absolute maximum rating conditions for extended periods may affect device reliability.

Parameters	Symbol	Value	Unit
Supply voltage	V_S	7.0	V
Ambient temperature range	T_{amb}	-40 to +125	°C
Storage temperature range	T_{stg}	-50 to +150	°C
Maximum junction temperature	T_j	+150	°C

6. Thermal Resistance

Parameters	Symbol	Value	Unit
Junction ambient	R_{thJA}	120	K/W

7. Electrical Characteristics

$V_S = 5V \pm 5\%$, $T_{amb} = 27^\circ C$, reference point pin 4 (GND), unless otherwise specified, see [Figure 1-1 on page 1](#)

Parameters	Test Conditions	Symbol	Min.	Typ.	Max.	Unit
Supply, Pin 11						
Supply voltage		V_S	4.75		5.25	V
Supply current	Inputs open Inputs switched to GND	I_S I_S	0.8 7		3.2 13	mA mA
Low-voltage detection threshold	ON OFF	$V_{TH(ON)}$ $V_{TH(OFF)}$	3.7 3.0		4.6 3.8	V V
Low-voltage hysteresis		V_{hyst}	0.55		1.05	V
Temperature shutdown		T_{Chip}	140		149	°C
Temperature shutdown hysteresis		T_{hyst}	5			°C
Inputs; Pins 8, 9, 10, 12, 13 and 14						
Z-diode protection voltage	$I_I = 10\text{ mA}$	V_I	6.7		8.5	V
Z-diode clamping current		I_I			± 10	mA
Pull-up resistor		R_I	170	250	305	k Ω
Switching threshold	OFF ON	V_I V_I		3.3 1.8		V V
Hysteresis		V_{hyst}		1.5		V
Outputs; Pins 1, 2, 3, 5, 6 and 7						
Z-diode protection voltage	$I_O = 10\text{ mA}$	V_O	26.5			V
Integrated capacitor				5		pF
Leakage current		I_{Leak}			2.5	μA
Saturation voltage	$I_O = 20\text{ mA}$	V_{Sat}			0.7	V
Current limitation		I_{limit}	25		100	mA
Propagation delay	470 pF, 1 k Ω , 20V	t_d			5	μs

8. Ordering Information

Extended Type Number	Package	Remarks
U6805B-MFPG3Y	SO14	Taped and reeled, Pb-free

9. Package Information

Package SO14
Dimensions in mm

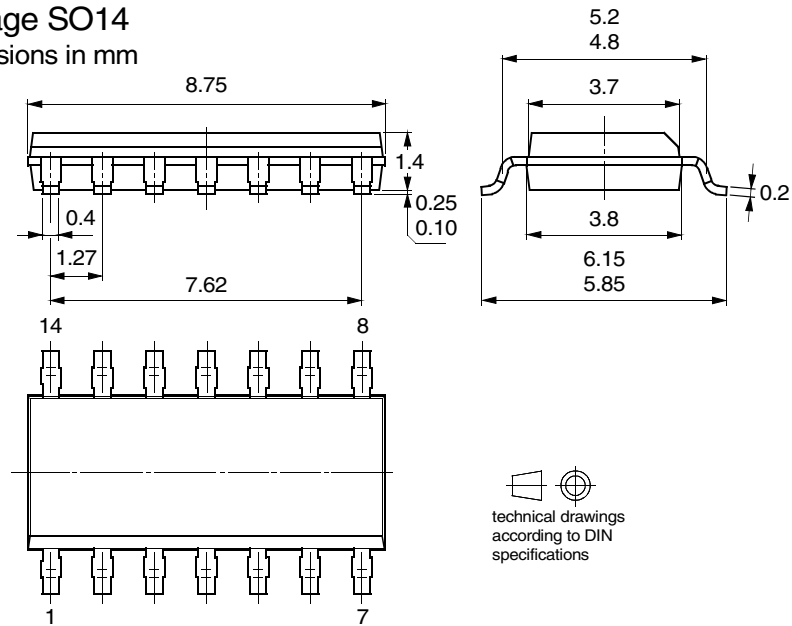

10. Revision History

Please note that the following page numbers referred to in this section refer to the specific revision mentioned, not to this document.

Revision No.	History
4763B-AUTO-09/05	<ul style="list-style-type: none"> Put datasheet in a new template Pb-free logo on page 1 added Table "Ordering Information" on page 6 changed



Atmel Corporation

2325 Orchard Parkway
San Jose, CA 95131, USA
Tel: 1(408) 441-0311
Fax: 1(408) 487-2600

Regional Headquarters

Europe

Atmel Sarl
Route des Arsenaux 41
Case Postale 80
CH-1705 Fribourg
Switzerland
Tel: (41) 26-426-5555
Fax: (41) 26-426-5500

Asia

Room 1219
Chinachem Golden Plaza
77 Mody Road Tsimshatsui
East Kowloon
Hong Kong
Tel: (852) 2721-9778
Fax: (852) 2722-1369

Japan

9F, Tonetsu Shinkawa Bldg.
1-24-8 Shinkawa
Chuo-ku, Tokyo 104-0033
Japan
Tel: (81) 3-3523-3551
Fax: (81) 3-3523-7581

Atmel Operations

Memory

2325 Orchard Parkway
San Jose, CA 95131, USA
Tel: 1(408) 441-0311
Fax: 1(408) 436-4314

Microcontrollers

2325 Orchard Parkway
San Jose, CA 95131, USA
Tel: 1(408) 441-0311
Fax: 1(408) 436-4314

La Chantrerie
BP 70602
44306 Nantes Cedex 3, France
Tel: (33) 2-40-18-18-18
Fax: (33) 2-40-18-19-60

ASIC/ASSP/Smart Cards

Zone Industrielle
13106 Rousset Cedex, France
Tel: (33) 4-42-53-60-00
Fax: (33) 4-42-53-60-01

1150 East Cheyenne Mtn. Blvd.
Colorado Springs, CO 80906, USA
Tel: 1(719) 576-3300
Fax: 1(719) 540-1759

Scottish Enterprise Technology Park
Maxwell Building
East Kilbride G75 0QR, Scotland
Tel: (44) 1355-803-000
Fax: (44) 1355-242-743

RF/Automotive

Theresienstrasse 2
Postfach 3535
74025 Heilbronn, Germany
Tel: (49) 71-31-67-0
Fax: (49) 71-31-67-2340

1150 East Cheyenne Mtn. Blvd.
Colorado Springs, CO 80906, USA
Tel: 1(719) 576-3300
Fax: 1(719) 540-1759

Biometrics/Imaging/Hi-Rel MPU/ High Speed Converters/RF Datacom

Avenue de Rochepleine
BP 123
38521 Saint-Egreve Cedex, France
Tel: (33) 4-76-58-30-00
Fax: (33) 4-76-58-34-80

Literature Requests

www.atmel.com/literature

Disclaimer: The information in this document is provided in connection with Atmel products. No license, express or implied, by estoppel or otherwise, to any intellectual property right is granted by this document or in connection with the sale of Atmel products. **EXCEPT AS SET FORTH IN ATMEL'S TERMS AND CONDITIONS OF SALE LOCATED ON ATMEL'S WEB SITE, ATMEL ASSUMES NO LIABILITY WHATSOEVER AND DISCLAIMS ANY EXPRESS, IMPLIED OR STATUTORY WARRANTY RELATING TO ITS PRODUCTS INCLUDING, BUT NOT LIMITED TO, THE IMPLIED WARRANTY OF MERCHANTABILITY, FITNESS FOR A PARTICULAR PURPOSE, OR NON-INFRINGEMENT. IN NO EVENT SHALL ATMEL BE LIABLE FOR ANY DIRECT, INDIRECT, CONSEQUENTIAL, PUNITIVE, SPECIAL OR INCIDENTAL DAMAGES (INCLUDING, WITHOUT LIMITATION, DAMAGES FOR LOSS OF PROFITS, BUSINESS INTERRUPTION, OR LOSS OF INFORMATION) ARISING OUT OF THE USE OR INABILITY TO USE THIS DOCUMENT, EVEN IF ATMEL HAS BEEN ADVISED OF THE POSSIBILITY OF SUCH DAMAGES.** Atmel makes no representations or warranties with respect to the accuracy or completeness of the contents of this document and reserves the right to make changes to specifications and product descriptions at any time without notice. Atmel does not make any commitment to update the information contained herein. Unless specifically provided otherwise, Atmel products are not suitable for, and shall not be used in, automotive applications. Atmel's products are not intended, authorized, or warranted for use as components in applications intended to support or sustain life.

© Atmel Corporation 2005. All rights reserved. Atmel®, logo and combinations thereof, Everywhere You Are® and others, are registered trademarks or trademarks of Atmel Corporation or its subsidiaries. Other terms and product names may be trademarks of others.



Printed on recycled paper.

4763B-AUTO-09/05