

Tous droits strictement réservés. Reproduction ou communication o des liers interdite sous quelque forme que ce soit sans autorisation écrite du propriétaire. Propriete de c FCI. Droits de reproduction FCI.

All rights strictly reserved. Reproduction or issue to third parties in any form whatever is not permitted without written authority from the proprietor. Property of FCI. Copyright FCI.

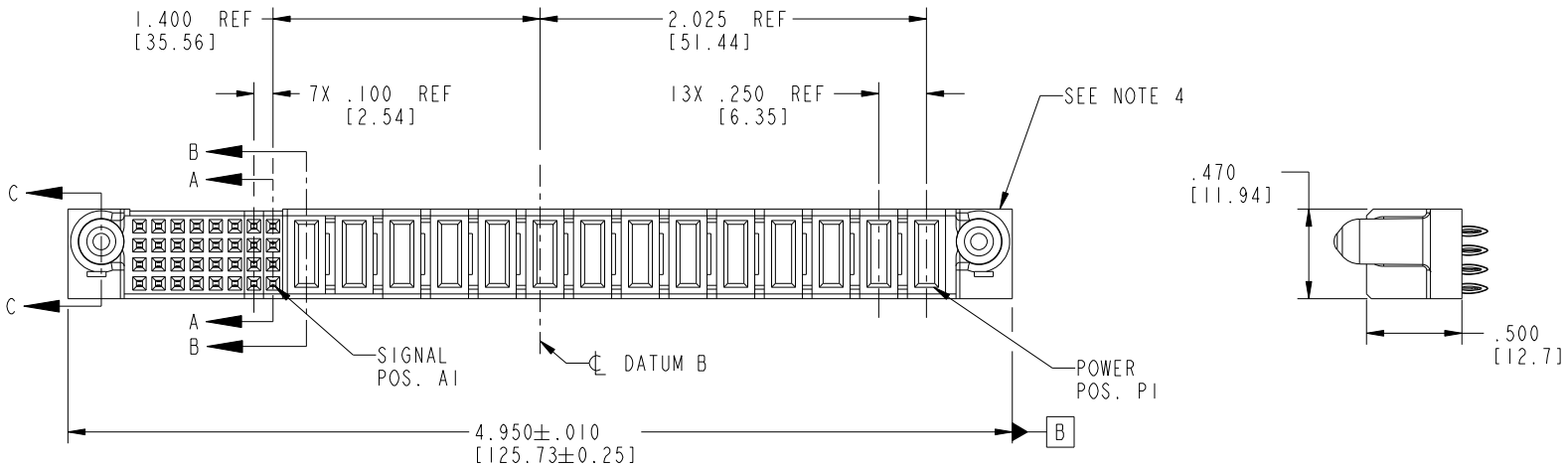

PRODUCT NO. 51752-013-- NOTE ③	ROWS D C B A	E2	SIGNAL					POWER														E1																													
			8	7	6	5	4	3	2	1	P14	P13	P12	P11	P10	P9	P8	P7	P6	P5	P4		P3	P2	P1																										
			F	F	F	F	F	F	F	F	F	F	F	F	F	F	F	F	F	F	F	F	F	F	F	F	F	F	F	F	PF	PC	PF	PC	PF	PC	PF	PC	PF	PC	PF	PC	PF	PC	PF	PC	PF	PC	PF	PC	



CODE	DIM "M" MATING LENGTH	CONTACT TYPE
PC	.042 [1.07]	POWER
F	N/A [N/A]	SIGNAL
PF	.092 [2.34]	POWER

mat'l code				SEE NOTE 2		tolerances unless otherwise specified		CUSTOMER		FCI	
lir	ecn no.	dr	date	linear	.XX±.01/0.X±0.3	projection		COPY		www.fciconnect.com	
A	DG05-0220	SW	07/14/05		.XXX±.005/0.XX±0.13	INCH/MM		title		14P + 32S	
B	DG08-0251	W D	09/13/08	angles	.XXX±.0020/0.XXX±0.051	scale		product family		PwrBlade	
				dr	0°±2°	1:1		size		213	
				enr	STEVEN WANG 07/14/05			dwg no		51752-013	
				chr	VICTOR LIN 07/14/05			sheet		1 of 4	
				appd	JOSEPH HSIA 07/14/05			code		213	
sheet index	revision sheet	B 1	B 2	B 3	B 4						

1 | 2

Pro/E

PDM: Rev:B

STATUS: Released

Printed: Dec 20, 2010

A

A

B

B

cage code 22526

4

Tous droits strictement réservés. Reproduction ou communication a des tiers interdite sous quelque forme que ce soit sans autorisation écrite du propriétaire. Propriété de c FCI. Droits de reproduction FCI.

All rights strictly reserved. Reproduction or issue to third parties in any form whatever is not permitted without written authority from the proprietor. Property of FCI. Copyright FCI.



PRODUCT NUMBER
51752-013--
NOTE ③

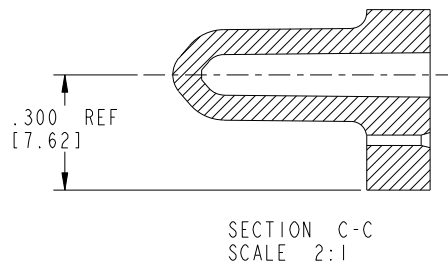
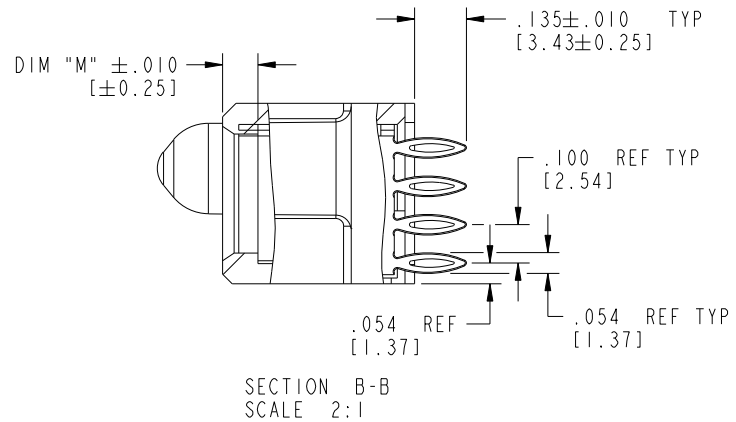
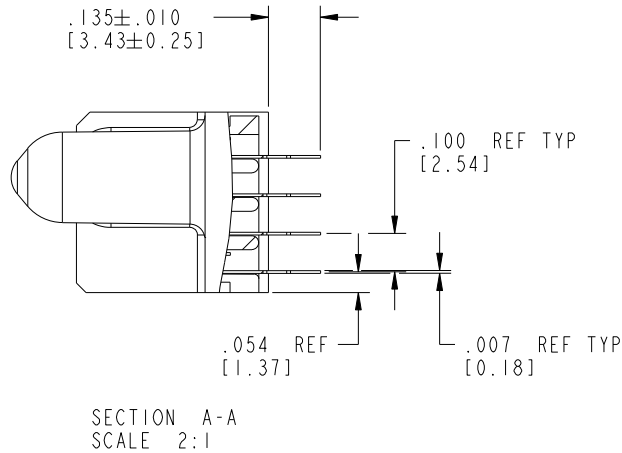

mat'l code		SEE NOTE 2		tolerances unless otherwise specified		CUSTOMER		FCI	
ltr	ecn no.	dr	date	linear	.XX±.01/0.X±0.3	COPY	www.fciconnect.com		
B				projection	.XX±.005/0.XX±0.13	INCH/MM	title 14P + 32S		
				angles	.XXX±.0020/0.XXX±0.051	INCH/MM	VERTICAL PRESS-FIT RECEPT		
				dr	0°±2°	scale	product family PwrBlade		code
				engr	STEVEN WANG 07/14/05	1:1	size	dwg no	213
				chr	VICTOR LIN 07/14/05		A 51752-013		sheet
				appd	JOSEPH HSIA 07/14/05				2 of 4
sheet index	revision sheet								

Pro/E

PDM: Rev: B

STATUS: Released

Printed: Dec 20, 2010

Tous droits strictement réservés. Reproduction ou communication a des tiers interdite sous quelque forme que ce soit sans autorisation écrite du propriétaire. Propriété de c FCI. Droits de reproduction FCI.



All rights strictly reserved. Reproduction or issue to third parties in any form whatever is not permitted without written authority from the proprietor. Property of FCI. Copyright FCI.

1 | 2

3

4

PRODUCT NUMBER
51752-013--
NOTE ③

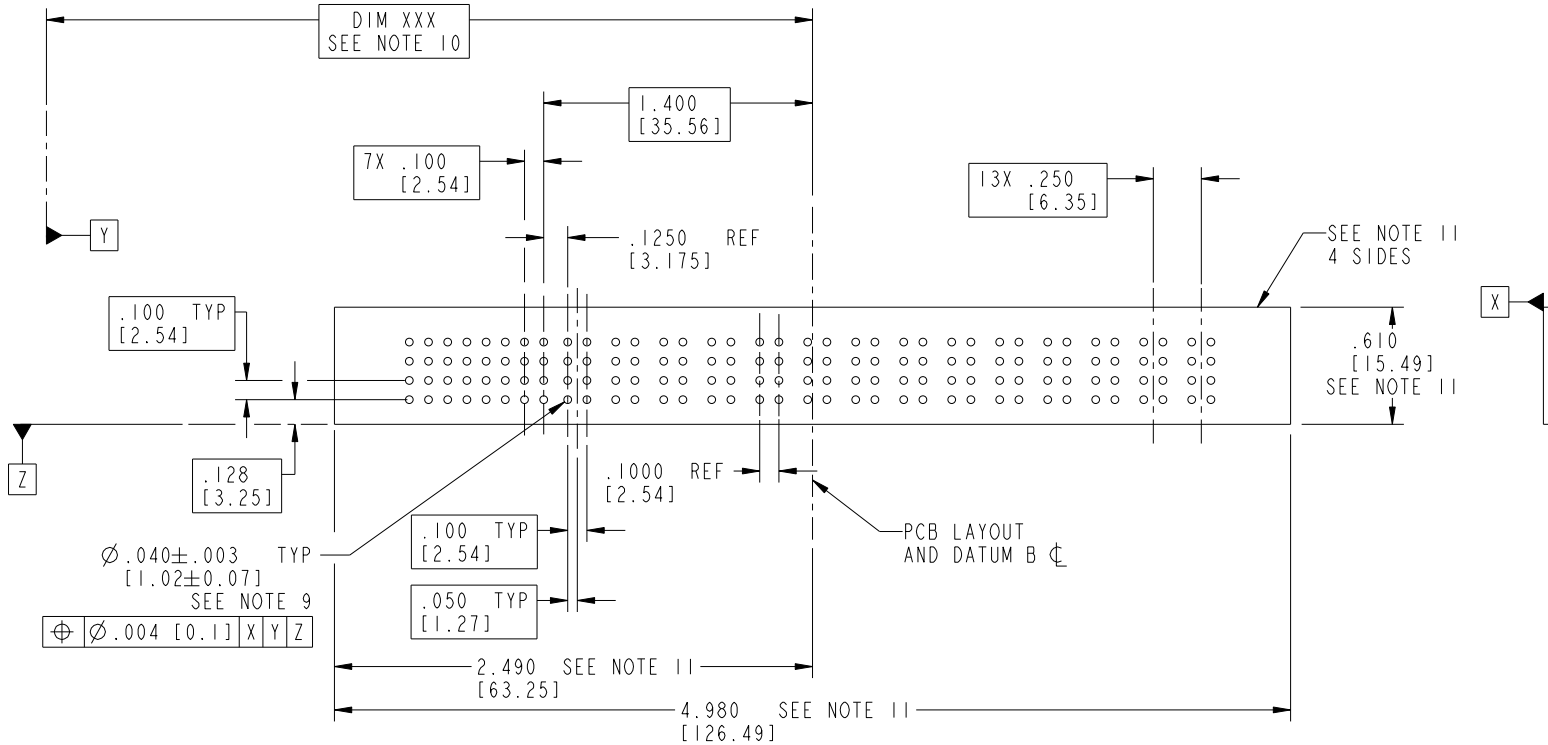

RECOMMENDED PCB LAYOUT

mat'l code		SEE NOTE 2		tolerances unless otherwise specified		CUSTOMER		FCI	
lfr	ecn no.	dr	date	linear	.XX±.01/0.X±0.3	COPY		www.fciconnect.com	
B				linear	.XX±.005/0.X±0.13	projection		title 14P + 32S	
				angles	.XXX±.0020/0.XXX±0.051	INCH/MM		VERTICAL PRESS-FIT RECEPT	
				dr	0°±2°	scale		product family PwrBlade code	
				engr	STEVEN WANG 07/14/05	1:1		size dwg no 213	
				chr	STEVEN WANG 07/14/05			sheet 3 of 4	
				appd	VICTOR LIN 07/14/05			A 51752-013	
					JOSEPH HSIA 07/14/05				
sheet index	revision sheet								

1 | 2

Pro/E

PDM: Rev: B

STATUS: Released

Printed: Dec 20, 2010

A

A

B

B

Tous droits strictement réservés. Reproduction ou communication a des tiers interdite sous quelque forme que ce soit sans autorisation écrite du propriétaire. Propriété de c FCI. Droits de reproduction FCI.



All rights strictly reserved. Reproduction or issue to third parties in any form whatever is not permitted without written authority from the proprietor. Property of FCI. Copyright FCI.

1 | 2

3 |

4

PRODUCT NUMBER
51752-013--
NOTE ③

NOTES:

1. DIMENSIONS AND TOLERANCES ARE IN ACCORDANCE WITH ASME Y14.5M, 1994 UNLESS OTHERWISE SPECIFIED.

CONNECTOR NOTES:

② HOUSING MATERIAL: UL 94 V-0 GLASS FILLED HIGH-TEMP THERMOPLASTIC
POWER CONTACT MATERIAL: COPPER ALLOY
SIGNAL PIN MATERIAL: COPPER ALLOY

ⓑ 3. SEE ITEM 7 & 8 IN PRINT 10064183 FOR PLATING SPEC OF 51752-013 AND 51752-013LF RESPECTIVELY.

④ MANUFACTURER'S NAME, P/N, AND DATE CODE TO APPEAR ON THIS SURFACE.

5. PRODUCT SPECIFICATION GS-12-149.
APPLICATION SPECIFICATION BUS-20-067.

6. PACKAGED IN TRAYS.

PCB NOTES:

7. ALL HOLE DIAMETERS ARE FINISHED HOLE SIZE.

⑧ MOUNTING HOLES, WHERE APPLICABLE, ARE UNPLATED.

⑨ $\varnothing .0453 \pm .0010$ [1.151 ± 0.025] DRILLED HOLES PLATED WITH
.0003 [0.008] MIN SnPb OVER .001 [0.03]
TO .003 [0.08] Cu PLATING TO ACHIEVE
 $\varnothing .040 \pm .003$ [1.02 ± .07] HOLE.

⑩ "DIM XXX" TO BE DETERMINED BY THE CUSTOMER.

⑪ CONNECTOR KEEP-OUT ZONE.

12. ⓑ SYMBOL WILL BE NEXT TO ANY DIMENSION, VIEW, OR NOTE WHICH HAS BEEN MODIFIED WITH THE CURRENT DRAWING REVISION.

mat'l code				SEE NOTE 2		tolerances unless otherwise specified		CUSTOMER		FCI		www.fciconnect.com	
ltr	ecn no.	dr	date	linear	.XX±.01/0.X±0.3		COPY		projection	title			14P + 32S
B					.XXY±.005/0.XX±0.13		INCH/MM			VERTICAL PRESS-FIT RECEIPT			
				angles	.XXX±.0020/0.XXX±0.051		scale		product family		code		
				dr	0° ± 2°		1:1		PwrBlade		213		
				enrg	STEVEN WANG 07/14/05		A		size		sheet		
				chr	STEVEN WANG 07/14/05		51752-013		dwg no		4 of 4		
				appd	VICTOR LIN 07/14/05								
					JOSEPH HSIA 07/14/05								
sheet index		revision sheet											

A

A

B

B

1 | 2

Pro/E

PDM: Rev: B

STATUS: Released

Printed: Dec 20, 2010

cage code 28526

4