

160W PFC Evaluation Board with DCM PFC controller TDA4863-2 and CoolMOS™ SPP08N50C3

Power Management & Supply



Never stop thinking.

Attention please!

The information herein is given to describe certain components and shall not be considered as warranted characteristics.

Terms of delivery and rights to technical change reserved.

We hereby disclaim any and all warranties, including but not limited to warranties of non-infringement, regarding circuits, descriptions and charts stated herein.

Infineon Technologies is an approved CECC manufacturer.

Information

For further information on technology, delivery terms and conditions and prices please contact your nearest Infineon Technologies Office in Germany or our Infineon Technologies Representatives worldwide (see address list).

Warnings

Due to technical requirements components may contain dangerous substances. For information on the types in question please contact your nearest Infineon Technologies Office.

Infineon Technologies Components may only be used in life-support devices or systems with the express written approval of Infineon Technologies, if a failure of such components can reasonably be expected to cause the failure of that life-support device or system, or to affect the safety or effectiveness of that device or system. Life support devices or systems are intended to be implanted in the human body, or to support and/or maintain and sustain and/or protect human life. If they fail, it is reasonable to assume that the health of the user or other persons may be endangered.



Confidential

Revision History:

Previous Version: -	
Page	Subjects (major changes since last revision)

Junyang Luo

Junyang.Luo@infineon.com

Simon Lim

Simon.Lim@infineon.com

Meng Kiat Jeoh

MengKiat.Jeoh@infineon.com

Infineon Technologies Asia Pacific Pte Ltd

© Infineon Technologies AP

All Rights Reserved.

<http://www.infineon.com>

We Listen to Your Comments

Any information within this document that you feel is wrong, unclear or missing at all? Your feedback will help us to continuously improve the quality of this document. Please send your proposal (including a reference to this document) to:

AP_Lab_Admin@infineon.com



Table of Contents

Topics	Page
Abstract	6
1 Evaluation Board	6
2 Technical specifications	7
3 Circuit Description	7
3.1 Line input	7
3.2 Current Sense	7
3.3 PWM control of Boost Converter	7
3.4 Gate Drive Output	8
4 Circuit Operation	8
4.1 Start up	8
4.2 Protection Features	9
4.2.1 Output over-voltage protection	9
4.2.2 IC supply under voltage lock out	9
5 Circuit Diagram	10
6 PCB Layout Top Layer	11
7 PCB layout Bottom Layer	12
8 Component List	13
9 Boost Choke Layout	14
10 Current Filter Choke Layout	14
11 Test report	15
11.1 Load test (table and figure)	15
11.2 Harmonic test according to EN61000-3-2 Class D Requirement	18
11.2.1 85VAC, full load (160W output)	18
11.2.2 85VAC, 8.25% of full load (13.2W output)	18
11.2.3 230VAC, full load (160W output)	19
11.2.4 230VAC, 8.25% of full load (13.2W output)	19

11.3	Waveforms (startup, full load operation and load jump)	20
11.3.1	Startup test at 230VAC, Iout = 0.4A	20
11.3.2	Full load operation at 230VAC, Iout = 0.4A	21
11.3.3	Load jump test at 230VAC, Iout from 0.033A to 0.4A	21
11.3.4	Load jump test at 230VAC, Iout from 0.4A to 0.33A	22
11.3.5	AC line jump test from 85VAC to 265VAC at full load	22
11.3.6	AC line drop test from 265VAC to 85VAC at full load	23
12	References	24

Abstract

The board described here was designed as a typical power factor correction (PFC) circuit in boost topology. The controller **TDA4863-2** chip used for this application is an 8-pin wide range input IC for active PFC converters. The IC operates in the discontinuous conduction mode (DCM) with peak current control. The **TDA4863-2** controls a boost converter in a way that sinusoidal current is taken from the single-phase line supply and stabilized DC voltage is available at the output. The circuit acts as a harmonic filter which limits the harmonic currents resulting from the pulse charge currents of the capacitor during rectification in a conventional capacitive input rectifier circuit. The power factor which describes the ratio between active and apparent power is almost 1 and line voltage fluctuations are compensated very efficiently, as well. To improve the efficiency, the third generation **CoolMOS™** is used as the power switch due to its lowest area specific $R_{ds(on)}$. This file introduces the new Infineon template. We have spent a lot of time and efforts in creating this template and we have tried to incorporate many individual proposals and desires wherever possible.

1 Evaluation Board

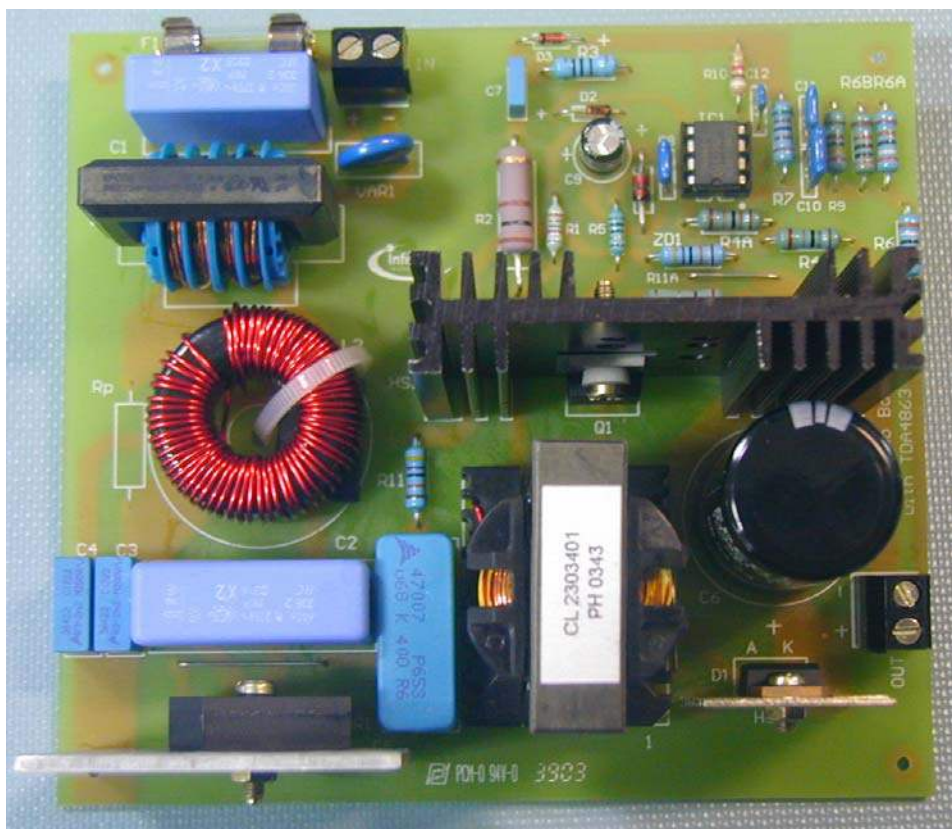

2 Technical specifications

Input voltage	85VAC~265VAC
Input frequency	50Hz, 60Hz
Output voltage and current	400VDC, 0.4A
Output power	160W
Efficiency	>85% at full load

3 Circuit Description

3.1 Line Input

The AC line input side comprises the input fuse F1 as over-current protection. The choke L1, X2-capacitors C1 and C2 and Y-capacitor CY1 and CY2 are used as radio interference suppressors. The high frequency current ripple is filtered by L2 and C2.

Power Stage – Boost Type PFC Converter

After the bridge rectifier BR1, there is a boost type PFC converter consisting of L3, Q1, D1 and C6. The third generation CoolMOS™ SPP08N50C3 is used as the power switch Q1. Due to its low R_{dson} , the small heat sink can fulfill the dissipation requirement. Output capacitor C2 provides energy buffering to reduce the output voltage ripple (100Hz) to the acceptable level.

3.2 Current Sense

The MOSFET current is sensed by the external shunt resistor R8 and R8A. The sense voltage is fed into TDA4863-2 Pin 4 and compares to the internal control voltage for PWM control.

3.3 PWM control of Boost Converter

The PWM control is realized by 8-Pin DCM PFC IC TDA4863-2. The output voltage is sensed by voltage divider consisted of R6, R6A, R6B and R7. The compensation network C10, C11, R9 constitutes the external circuitry of the error amplifier. This circuitry allows the feedback to be matched to various load conditions, thereby providing stable control. In order not to make the response for 100Hz ripple, the loop compensation is implemented with low bandwidth. The output voltage of the error amplifier

is sent to the internal multiplier and multiplied with sine wave sensing signal. The multiplier output is used as internal control voltage for peak current mode PWM control. The gate is turned off when peak current sensing signal exceeds the control voltage.

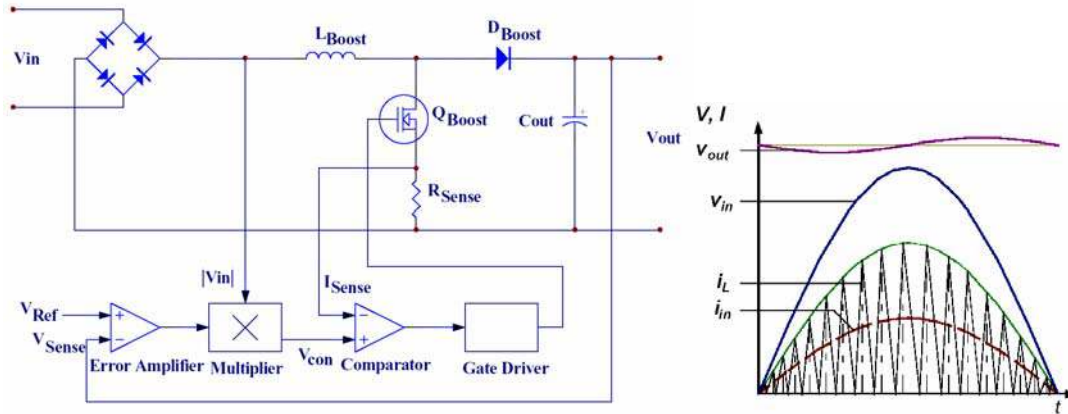

The zero current detector senses the inductor current via an auxiliary winding and ensures that the next on-time of the MOSFET is initiated immediately when the inductor current has reached zero. This reduces the reverse recovery losses of the boost converter diode to a minimum. The IC supply is provided by the auxiliary winding as well and filtered and buffered by C8 and C9. Resistor R3 is used to limit the IC supply current. The popular charge pump circuit of D3, R2 and C7 is implemented for the IC supply in wide range input voltage. ZD1 is used to limit the IC supply voltage within the operating range.

3.4 Gate Drive Output

The IC output gate driver is a fast totem pole gate drive and specially designed to drive large MOS transistor. The gate drive resistor R5 is selected to limit and gate pulse current and drive MOSFET for fast switching.

4 Circuit Operation

4.1 Start up

From the rectified bulk capacitor DC voltage, the chip's starting current supply is derived using the resistors R4 and R4A. Because of the low current less than 100uA, high-value resistors can be used. Series connection of the resistors is necessary for reasons of insufficient dielectric

strength of the individual resistors. The IC remains inactive during the Vcc charge up. When Vcc pin is higher than turn-on threshold, typical 12.5V, PFC is going to start. During the startup, the peak current limit is activated and maximum power is delivered to the output for fast startup.

4.2 Protection Features

4.2.1 Output over-voltage protection

Because of the inherent low bandwidth of PFC circuit, fast changes of the output voltage can't be regulated within an adequate time. Fast output changes occur during initial start-up, sudden load removal, or output arcing. The unique output over-voltage protection is integrated by sensing the current flowing into the IC Pin 2 VAOUT. If this current exceeds an internal defined margin, typical 40uA, over-voltage regulator circuitry is activated and reduces the multiplier output voltage. As a result the on time of the MOSFET is reduced. The OVP protection threshold is obtained as below:

$$V_{OVP} = 40\mu A \cdot R_H + 2.5V \cdot \frac{R_L + R_H}{R_L}$$

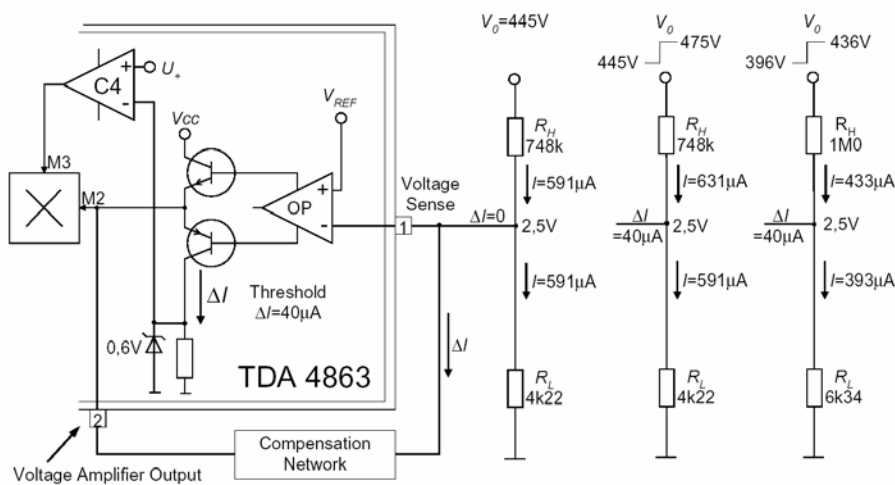

4.2.2 IC supply under voltage lock out

When VCC voltage is below the under voltage lockout threshold Vccoff, typical 10V, IC is off the gate drive is internally pull low to maintain the off state. Vcc is charged up for auto-restart.

5 Circuit Diagram

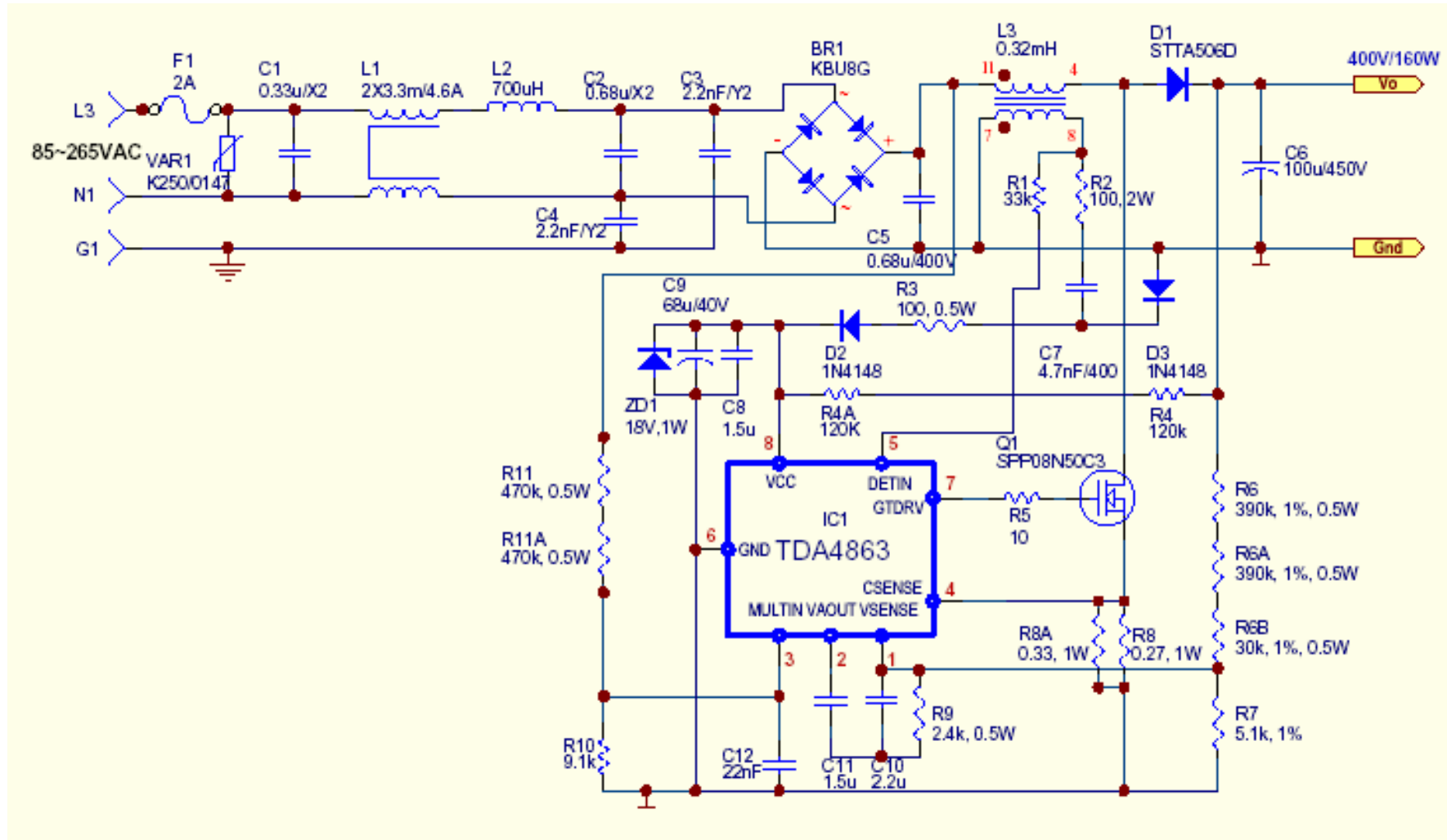

6 PCB layout top layer

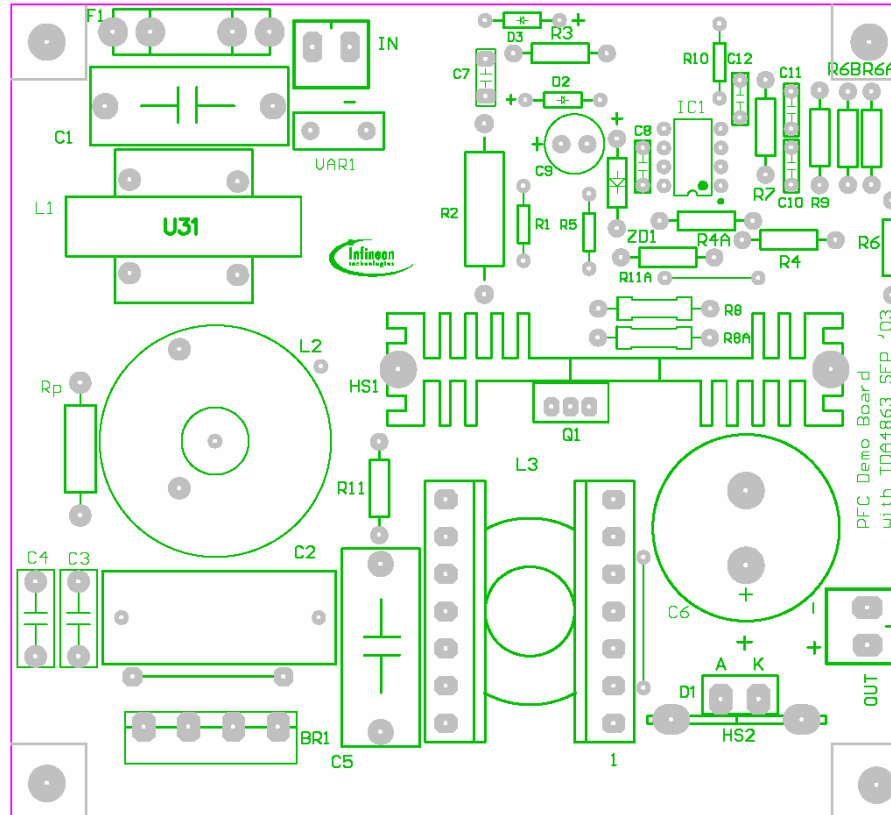

7 PCB layout Bottom Layer

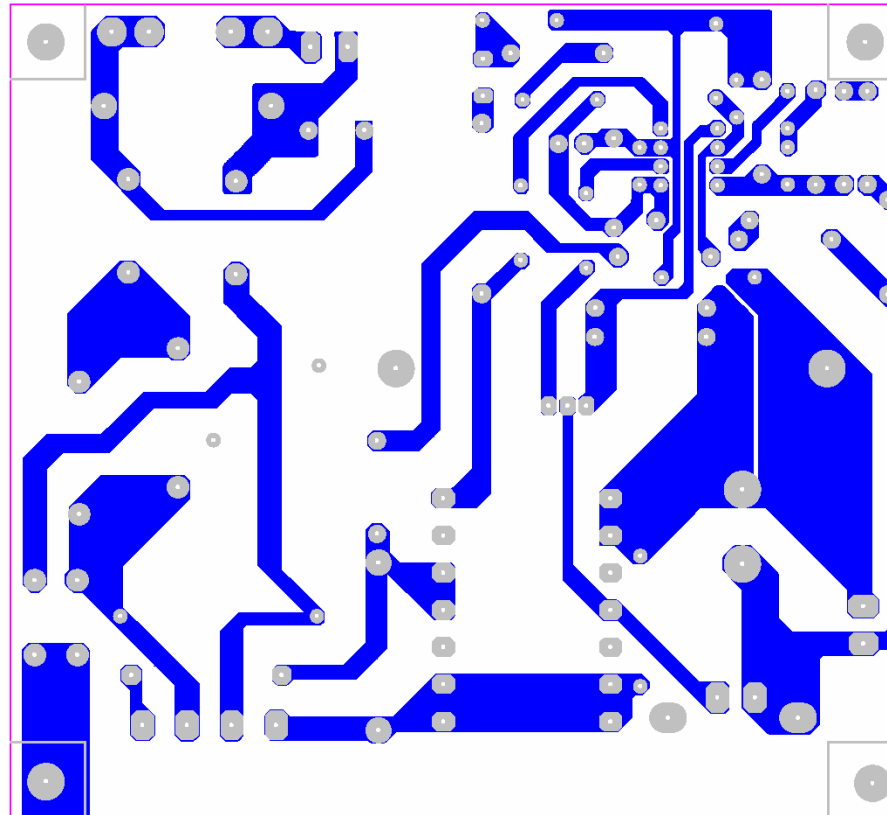

8 Component List

Item No	Designator	Part Type	Quantity
1	BR1	KBU8G	1
2	C1	u33/X2	1
3	C2	u68/X2	1
4	C3	2.2nF/Y2	1
5	C4	2.2n/Y2	1
6	C5	0.68u/400	1
7	C6	100u/450V	1
8	C7	4.7nF/400	1
9	C8	1.5u	1
10	C9	68u/40	1
11	C10	2.2u	1
12	C11	1.5u	1
13	C12	22nF	1
14	D1	STTA506D	1
15	D2	1N4148	1
16	D3	1N4148	1
17	F1	2A	1
18		Fuse Holder	2
19	HS1	Heatsink for Q1	1
20	HS2	Heatsink for D1	1
21	IC1	TDA4863-2	1
22		DIP8 IC Socket	1
23	INPUT	Connector	1
24	L1	2X3.3mH/4.6A	1
25	L2	700uH	1
26	L3	0.32mH	1
27	OUT	Connector	1
28	Q1	SPP08N50C3	1
29		T0220 Isolation Pad	1
30		Bushes	1
31		3mm Screw	2
32		3mm Nut	2
33	R1	33K	1
34	R2	100,2	1
35	R3	100,0.5	1
36	R4	120k,0.5	1

37	R4A	120k, 0.5	1
38	R5	10	1
39	R6	390k, 1%, 0.5	1
40	R6A	390k, 1%, 0.5	1
41	R6B	30k, 1%	1
42	R7	5.1K, 1%	1
43	R8	0.27, 1	1
44	R8A	0.33, 1	1
45	R9	2.4k, 0.5	1
46	R10	9.1K	1
47	R11	470K, 0.5	1
48	R11A	470K, 0.5	1
49	VAR1	K250/0147	1
50	ZD1	18V, 1W	1
51		15mm Jumper	1
52		25mm Jumper	2

9 Boost Choke Layout

Layer No.	Start	Stop	No. of Turns	Wire Size
7	8	7	17	1 x Φ 0.2mm
6		11	14	3 x Φ 0.5mm
5			14	3 x Φ 0.5mm
4			14	3 x Φ 0.5mm
3			14	3 x Φ 0.5mm
2			14	3 x Φ 0.5mm
1	4		14	3 x Φ 0.5mm
Core Inside				

Core: ER35/N67

Inductance, $L=320\mu\text{H}$, measured between pin 4 and pin 11

10 Current Filter Choke Layout

Core: CS270125 toriod

Turns: 66

Wire: 1 x Φ 0.7mm, AWG21

Inductance: $L=700\mu\text{H}$,

11 Test report

11.1 Load test (table and figure)

Input Voltage (Vac)	Input Current (A)	Input Power (W)	Output Voltage (Vdc)	Output Current (A)	Output Power (W)	PF	Efficiency (%)
85	0.226	18.45	405	0.033	13.37	0.964	72.44
	0.3	24.71	405	0.05	20.25	0.974	81.95
	0.569	47.81	405	0.1	40.50	0.993	84.71
	0.813	68.64	405	0.15	60.75	0.997	88.51
	1.09	91.95	405	0.2	81.00	0.998	88.09
	1.341	113.26	405	0.25	101.25	0.999	89.40
	1.596	134.6	405	0.3	121.50	0.999	90.27
	1.884	158.8	405	0.35	141.75	0.999	89.26
	2.15	180.99	405	0.4	162.00	0.999	89.51
110	0.188	18.98	405	0.033	13.37	0.918	70.42
	0.242	25.2	405	0.05	20.25	0.95	80.36
	0.444	47.92	405	0.1	40.50	0.986	84.52
	0.628	68.3	405	0.15	60.75	0.995	88.95
	0.836	91.35	405	0.2	81.00	0.996	88.67
	1.025	112.01	405	0.25	101.25	0.998	90.39
	1.214	132.7	405	0.3	121.50	0.998	91.56
	1.426	155.87	405	0.35	141.75	0.999	90.94
	1.619	176.9	405	0.4	162.00	0.999	91.58

**160W PFC Evaluation Board with DCM PFC
controller TDA4863-2 and CoolMOS™ SPP08N50C3**

230	0.161	19.37	405	0.033	13.37	0.543	69.00
	0.19	26	405	0.05	20.25	0.594	77.88
	0.275	47	405	0.1	40.50	0.754	86.17
	0.328	67.14	405	0.15	60.75	0.893	90.48
	0.409	89.69	405	0.2	81.00	0.955	90.31
	0.493	109.7	405	0.25	101.25	0.97	92.30
	0.577	129.55	405	0.3	121.50	0.978	93.79
	0.672	151.83	405	0.35	141.75	0.984	93.36
	0.757	171.91	405	0.4	162.00	0.988	94.24
265	0.14	18.39	405	0.033	13.37	0.493	72.68
	0.159	25.06	405	0.05	20.25	0.594	80.81
	0.266	47.34	405	0.1	40.50	0.678	85.55
	0.33	66.5	405	0.15	60.75	0.761	91.35
	0.382	88.14	405	0.2	81.00	0.871	91.90
	0.431	108.15	405	0.25	101.25	0.948	93.62
	0.504	128.02	405	0.3	121.50	0.961	94.91
	0.584	150.1	405	0.35	141.75	0.971	94.44
	0.658	170.11	405	0.4	162.00	0.978	95.23

160W PFC Evaluation Board with DCM PFC controller TDA4863-2 and CoolMOS™ SPP08N50C3

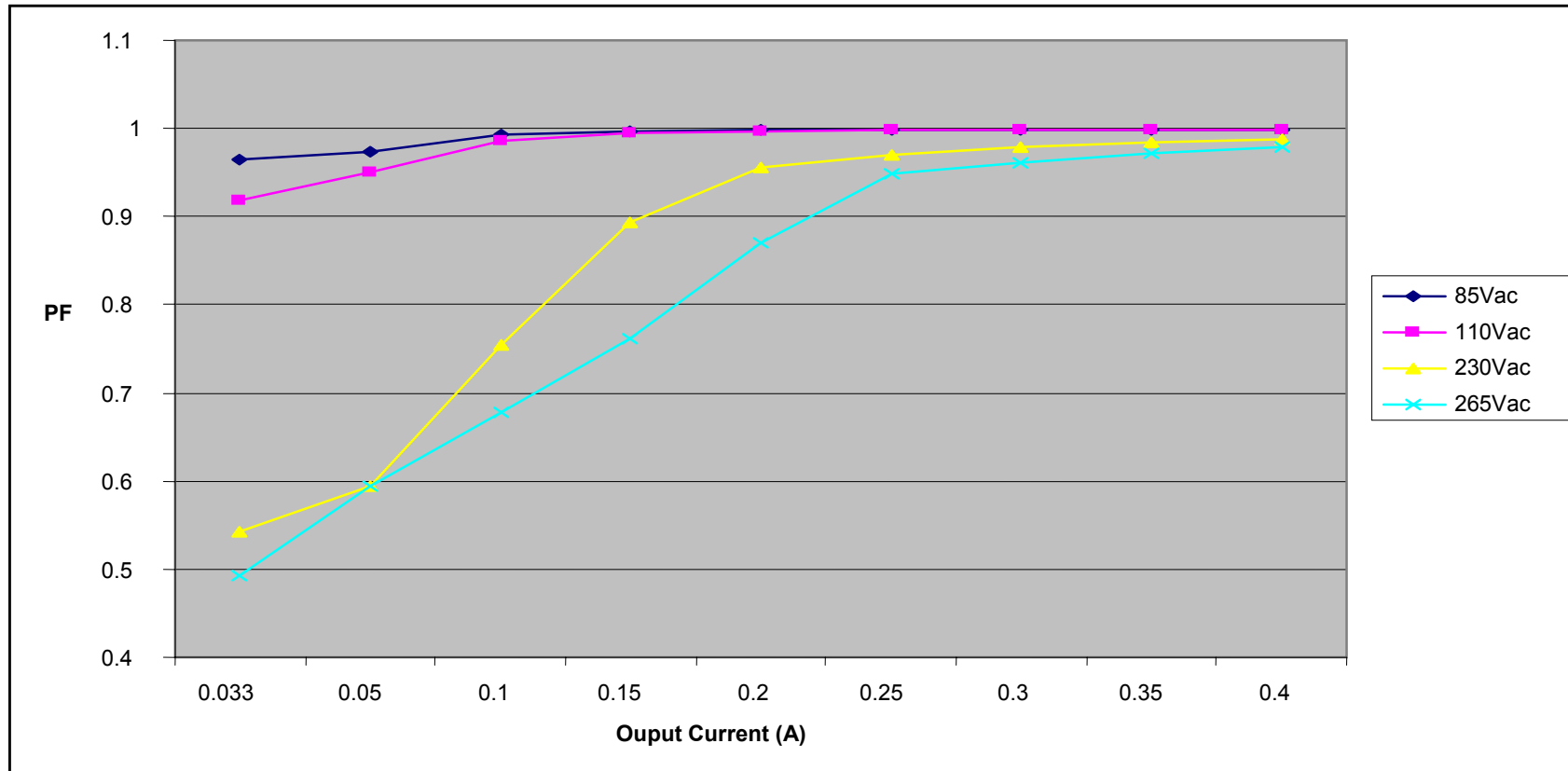

11.2 Harmonic test according to EN61000-3-2 Class D requirement

11.2.1 85VAC, full load (160W output)

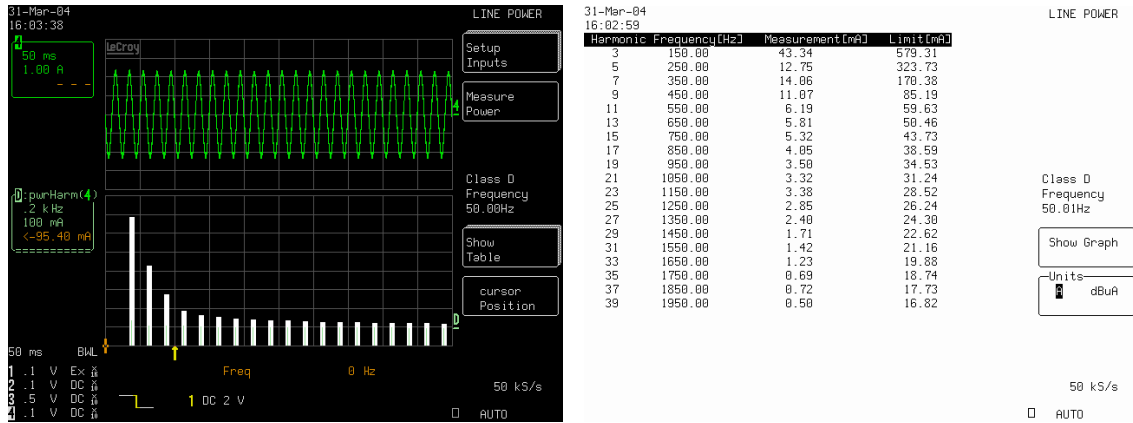

11.2.2 85VAC, 8.25% of full load (13.2W output)

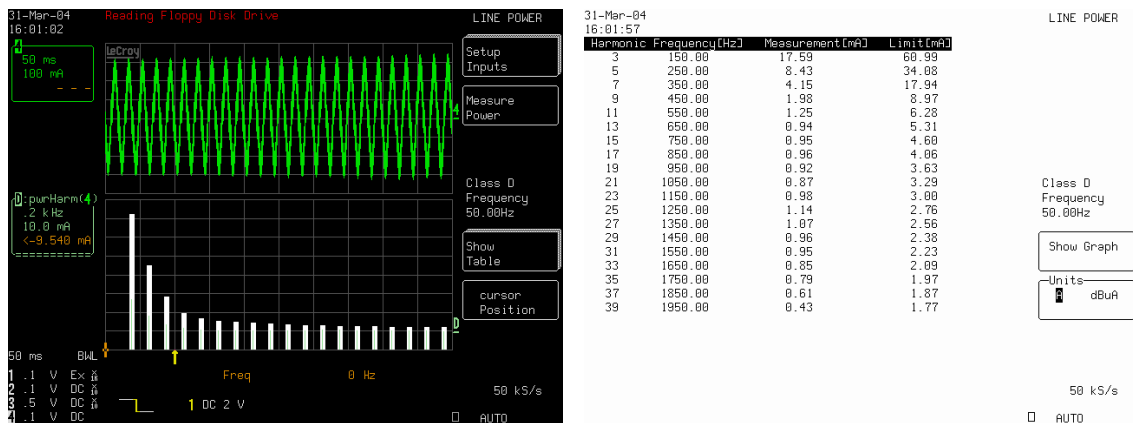

11.2.3 230VAC, full load (160W output)

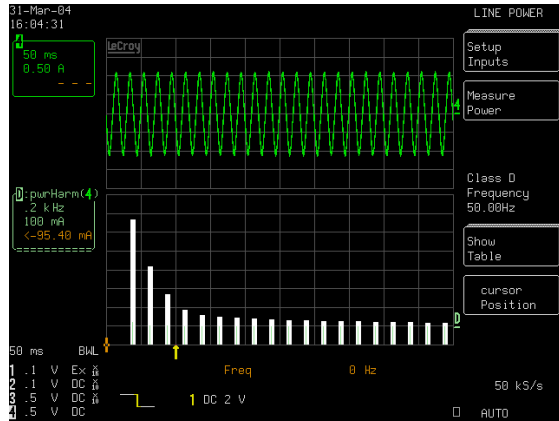

Harmonic	Frequency [Hz]	Measurement [mA]	Limit [mA]
3	150.00	25.50	561.03
5	250.00	7.03	313.52
7	350.00	8.07	165.01
9	450.00	5.32	82.50
11	550.00	4.11	57.75
13	650.00	3.21	48.87
15	750.00	2.15	42.35
17	850.00	1.65	37.37
19	950.00	1.56	33.44
21	1050.00	1.48	30.25
23	1150.00	1.59	27.62
25	1250.00	1.65	25.41
27	1350.00	1.70	23.53
29	1450.00	1.64	21.91
31	1550.00	1.58	20.49
33	1650.00	1.72	19.25
35	1750.00	1.80	18.15
37	1850.00	1.69	17.17
39	1950.00	1.66	16.29

LINE POWER

Class D Frequency 49.99Hz

Show Graph

Units dBuA

50 kS/s

AUTO

11.2.4 230VAC, 8.25% of full load (13.2W output)

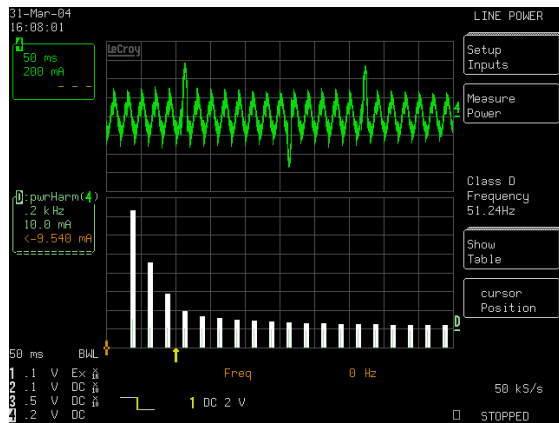

Harmonic	Frequency [Hz]	Measurement [mA]	Limit [mA]
3	150.00	20.72	62.21
5	250.00	8.99	34.77
7	350.00	2.36	18.30
9	450.00	3.72	9.15
11	550.00	3.57	6.40
13	650.00	3.40	5.42
15	750.00	2.66	4.70
17	850.00	2.48	4.14
19	950.00	2.17	3.71
21	1050.00	2.00	3.35
23	1150.00	1.54	3.06
25	1250.00	1.55	2.82
27	1350.00	1.46	2.61
29	1450.00	1.37	2.43
31	1550.00	1.34	2.27
33	1650.00	1.30	2.13
35	1750.00	1.25	2.01
37	1850.00	1.27	1.90
39	1950.00	1.32	1.81

LINE POWER

Class D Frequency 51.24Hz

Show Graph

Units dBuA

50 kS/s

STOPPED

AUTO

11.3 Waveforms (startup, full load operation and load jump)

11.3.1 Startup test at 230VAC, I_{out}=0.4A

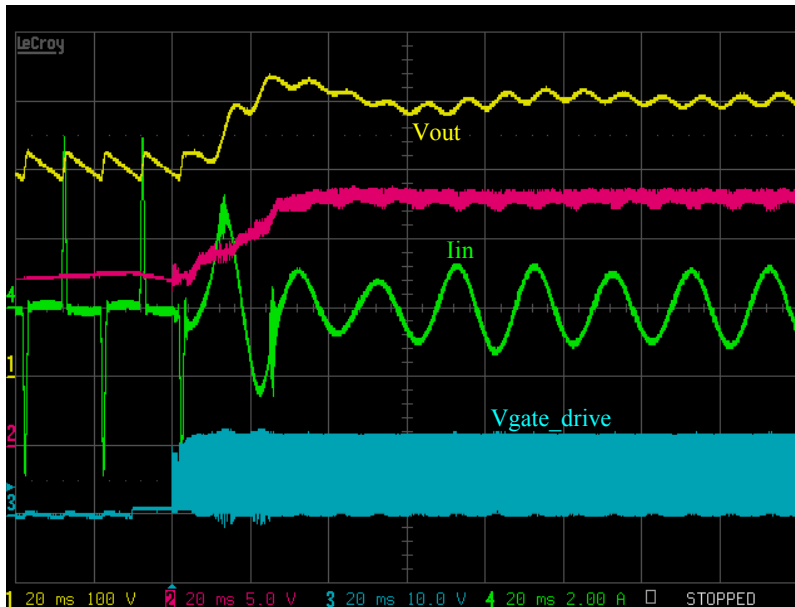
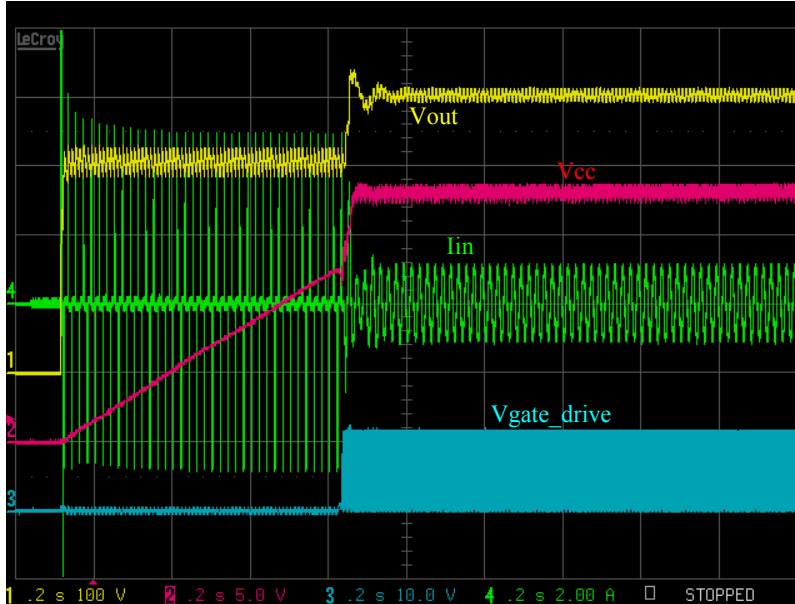

11.3.2 full load operation at 230VAC, I_{out}=0.4A

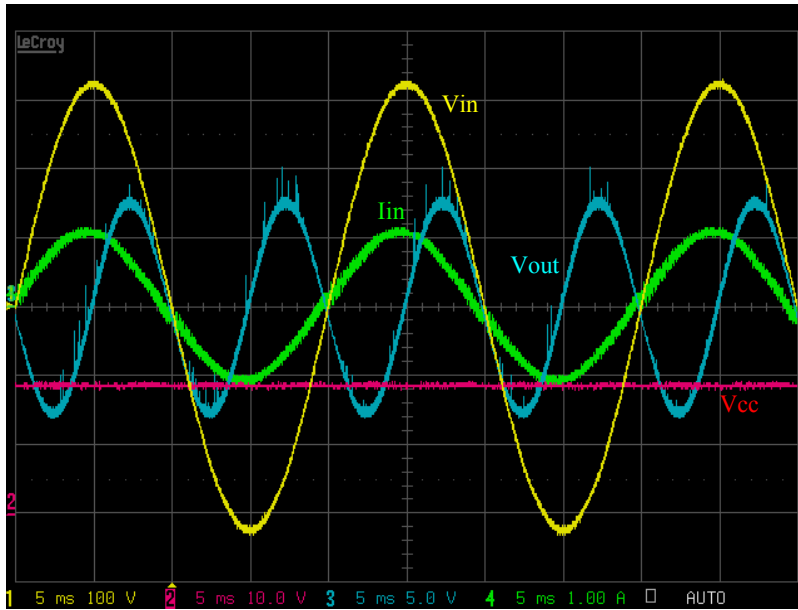

11.3.3 Load jump test at 230VAC, I_{out} from 0.033A to 0.4A

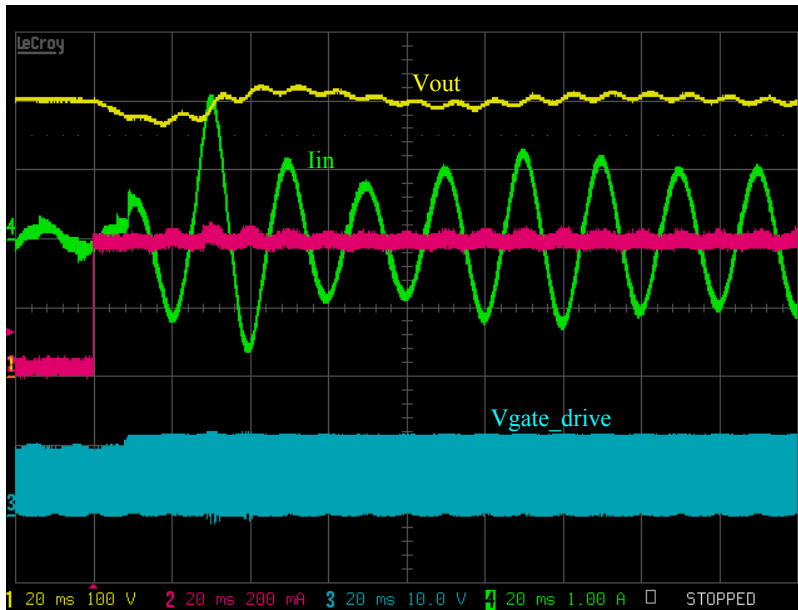

11.3.4 Load jump test at 230VAC, Iout from 0.4A to 0.033A

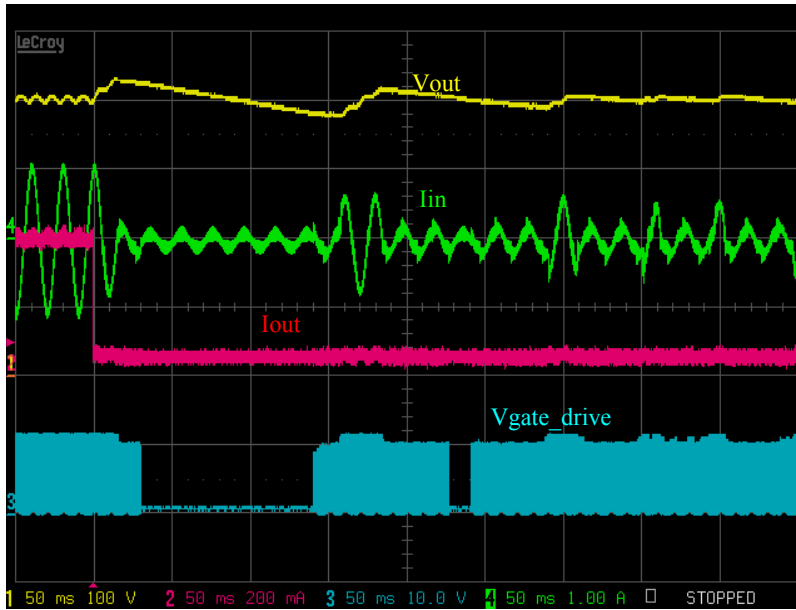

11.3.5 AC line jump test from 85VAC to 265VAC at full load

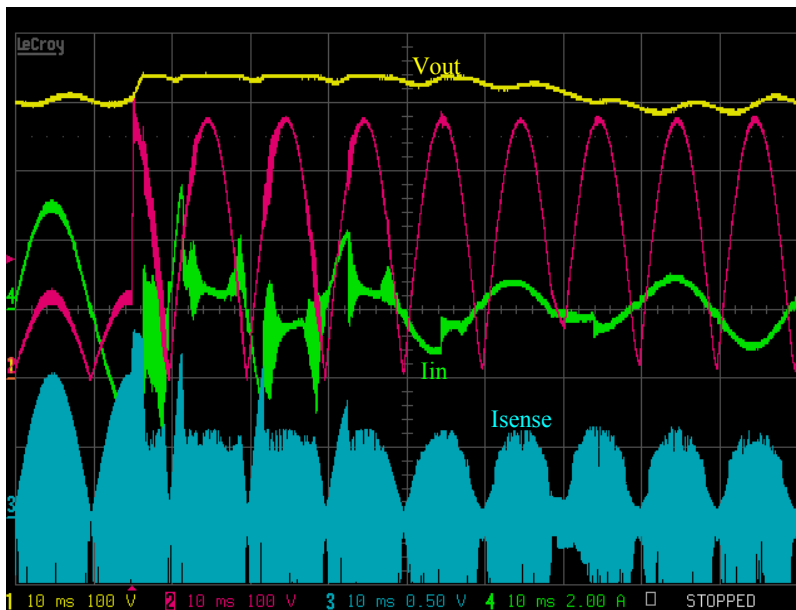

11.3.6 AC line drop test from 265VAC to 85VAC at full load

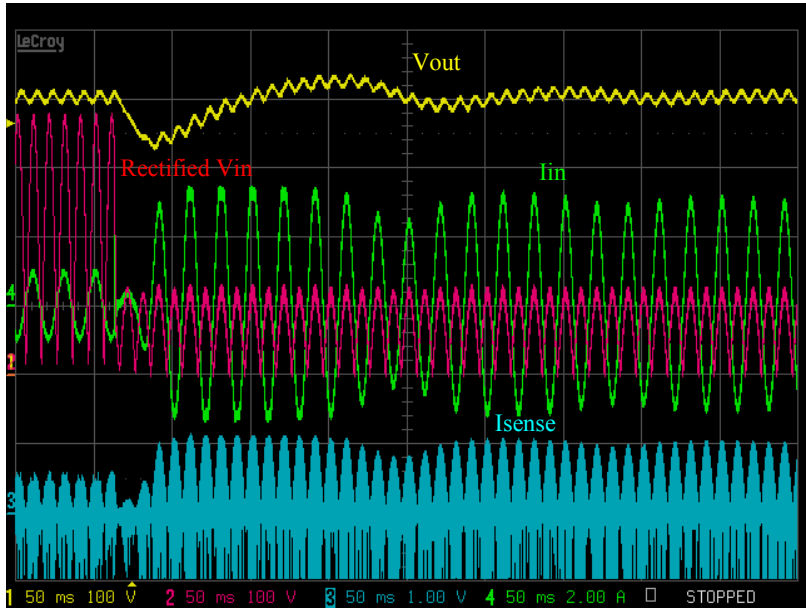

12 References:

- [1] Infineon Technologies: Boost Controller - TDA4863-2 Power Factor Controller IC for High Power Factor and Low THD; Final datasheet; Infineon Technologies; Munich; Germany; Feb. 2004
- [2] Wolfgang Frank, Michael Herfurth, TDA4863 - Technical Description, Application Note, Infineon Technologies; Munich; Germany; April 2002
- [3] Wolfgang Frank, Calculation-Tool for PFC-Preconverter using TDA4863, Application Note, Infineon Technologies; Munich; Germany; June 2002
- [4] Wolfgang Frank, TDA4863 Driving MOSFET with large Capacitances Application Note, Infineon Technologies; Munich; Germany; March 2003