

CAT93C76

8-Kb Microwire Serial EEPROM

Description

The CAT93C76 is an 8-Kb Serial EEPROM memory device which is configured as either registers of 16 bits (ORG pin at V_{CC} or Not Connected) or 8 bits (ORG pin at GND). Each register can be written (or read) serially by using the DI (or DO) pin. The CAT93C76 is manufactured using ON Semiconductor's advanced CMOS EEPROM floating gate technology. The device is designed to endure 1,000,000 program/erase cycles and has a data retention of 100 years. The device is available in 8-pin PDIP, SOIC, TSSOP and 8-pad TDFN packages.

Features

- High Speed Operation: 3 MHz @ $V_{CC} \geq 2.5$ V
- Low Power CMOS Technology
- 1.8 to 5.5 Volt Operation
- Selectable x8 or x16 Memory Organization
- Self-timed Write Cycle with Auto-clear
- Software Write Protection
- Power-up Inadvertant Write Protection
- 1,000,000 Program/Erase Cycles
- 100 Year Data Retention
- Industrial and Extended Temperature Ranges
- Sequential Read
- "Green" Package Option Available
- This Device is Pb-Free, Halogen Free/BFR Free and RoHS Compliant

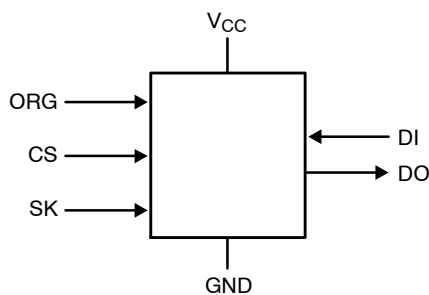

Figure 1. Functional Symbol

NOTE: When the ORG pin is connected to V_{CC} , the x16 organization is selected. When it is connected to ground, the x8 organization is selected. If the ORG pin is left unconnected, then an internal pull-up device will select the x16 organization.



ON Semiconductor®

<http://onsemi.com>



SOIC-8
V SUFFIX
CASE 751BD



TDFN-8
ZD4 SUFFIX
CASE 511AL

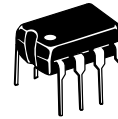

PDIP-8
L SUFFIX
CASE 646AA



TSSOP-8
Y SUFFIX
CASE 948AL

PIN CONFIGURATION



PDIP (L), SOIC (V),
TSSOP (Y), TDFN (ZD4)

PIN FUNCTION

Pin Name	Function
CS	Chip Select
SK	Serial Clock Input
DI	Serial Data Input
DO	Serial Data Output
V_{CC}	Power Supply
GND	Ground
ORG	Memory Organization
NC	No Connection

ORDERING INFORMATION

See detailed ordering and shipping information in the package dimensions section on page 12 of this data sheet.

CAT93C76

Table 1. ABSOLUTE MAXIMUM RATINGS

Parameters	Ratings	Units
Temperature Under Bias	-55 to +125	°C
Storage Temperature	-65 to +150	°C
Voltage on any Pin with Respect to Ground (Note 1)	-2.0 to +V _{CC} +2.0	V
V _{CC} with Respect to Ground	-2.0 to +7.0	V
Lead Soldering Temperature (10 seconds)	300	°C
Output Short Circuit Current (Note 2)	100	mA

Stresses exceeding Maximum Ratings may damage the device. Maximum Ratings are stress ratings only. Functional operation above the Recommended Operating Conditions is not implied. Extended exposure to stresses above the Recommended Operating Conditions may affect device reliability.

1. The minimum DC input voltage is -0.5 V. During transitions, inputs may undershoot to -2.0 V for periods of less than 20 ns. Maximum DC voltage on output pins is V_{CC} +0.5 V, which may overshoot to V_{CC} +2.0 V for periods of less than 20 ns.
2. Output shorted for no more than one second.

Table 2. RELIABILITY CHARACTERISTICS (Note 2)

Symbol	Parameter	Reference Test Method	Min	Units
N _{END} (Note 3)	Endurance	MIL-STD-883, Test Method 1033	1,000,000	Cycles / Byte
T _{DR} (Note 3)	Data Retention	MIL-STD-883, Test Method 1008	100	Years
V _{ZAP} (Note 3)	ESD Susceptibility	MIL-STD-883, Test Method 3015	2,000	V
I _{LTH} (Notes 3, 4)	Latch-Up	JEDEC Standard 17	100	mA

3. These parameters are tested initially and after a design or process change that affects the parameter.
4. Latch-up protection is provided for stresses up to 100 mA on I/O pins from -1 V to V_{CC} + 1 V.

Table 3. D.C. OPERATING CHARACTERISTICS (V_{CC} = +1.8 V to +5.5 V unless otherwise specified.)

Symbol	Parameter	Test Conditions	Min	Typ	Max	Units
I _{CC1}	Power Supply Current (Write)	f _{SK} = 1 MHz, V _{CC} = 5.0 V		1	3	mA
I _{CC2}	Power Supply Current (Read)	f _{SK} = 1 MHz, V _{CC} = 5.0 V		300	500	μA
I _{SB1}	Power Supply Current (Standby) (x8 Mode)	CS = 0 V, ORG = GND		2	10	μA
I _{SB2}	Power Supply Current (Standby) (x16 Mode)	CS = 0 V, ORG = Float or V _{CC}		0 (Note 5)	10	μA
I _{LI}	Input Leakage Current	V _{IN} = 0 V to V _{CC}		0 (Note 5)	10	μA
I _{LO}	Output Leakage Current	V _{OUT} = 0 V to V _{CC} , CS = 0 V		0 (Note 5)	10	μA
I _{LORG}	ORG Pin Leakage Current	ORG = GND or ORG = V _{CC}		1	10	μA
V _{IL1}	Input Low Voltage	4.5 V ≤ V _{CC} ≤ 5.5 V	-0.1		0.8	V
V _{IH1}	Input High Voltage	4.5 V ≤ V _{CC} ≤ 5.5 V	2		V _{CC} + 1	V
V _{IL2}	Input Low Voltage	1.8 V ≤ V _{CC} < 4.5 V	0		V _{CC} × 0.2	V
V _{IH2}	Input High Voltage	1.8 V ≤ V _{CC} < 4.5 V	V _{CC} × 0.7		V _{CC} + 1	V
V _{OL1}	Output Low Voltage	4.5 V ≤ V _{CC} ≤ 5.5 V, I _{OL} = 2.1 mA			0.4	V
V _{OH1}	Output High Voltage	4.5 V ≤ V _{CC} ≤ 5.5 V, I _{OH} = -400 μA	2.4			V
V _{OL2}	Output Low Voltage	1.8 V ≤ V _{CC} < 4.5 V, I _{OL} = 100 μA			0.1	V
V _{OH2}	Output High Voltage	1.8 V ≤ V _{CC} < 4.5 V, I _{OH} = -100 μA	V _{CC} - 0.2			V

5. 0 μA is defined as less than 900 nA.

Table 4. PIN CAPACITANCE (Note 3)

Symbol	Test	Conditions	Min	Typ	Max	Units
C _{OUT}	Output Capacitance (DO)	V _{OUT} = 0 V			5	pF
C _{IN}	Input Capacitance (CS, SK, DI, ORG)	V _{IN} = 0 V			5	pF

CAT93C76

Table 5. INSTRUCTION SET (Note 6)

Instruction	Start Bit	Opcode	Address		Data		Comments
			x8	x16	x8	x16	
READ	1	10	A10–A0	A9–A0			Read Address AN– A0
ERASE	1	11	A10–A0	A9–A0			Clear Address AN– A0
WRITE	1	01	A10–A0	A9–A0	D7–D0	D15–D0	Write Address AN– A0
EWEN	1	00	11XXXXXXXXXX	11XXXXXXXXXX			Write Enable
EWDS	1	00	00XXXXXXXXXX	00XXXXXXXXXX			Write Disable
ERAL	1	00	10XXXXXXXXXX	10XXXXXXXXXX			Clear All Addresses
WRAL	1	00	01XXXXXXXXXX	01XXXXXXXXXX	D7–D0	D15–D0	Write All Addresses

6. Address bit A10 for the 1,024x8 org. and A9 for the 512x16 org. are “don’t care” bits, but must be kept at either a “1” or “0” for READ, WRITE and ERASE commands.

Table 6. A.C. CHARACTERISTICS

Symbol	Parameter	Test Conditions	Limits				Units
			$V_{CC} = 1.8\text{ V} - 2.5\text{ V}$		$V_{CC} = 2.5\text{ V} - 5.5\text{ V}$		
			Min	Max	Min	Max	
t_{CSS}	CS Setup Time		100		50		ns
t_{CSH}	CS Hold Time		0		0		ns
t_{DIS}	DI Setup Time		100		50		ns
t_{DIH}	DI Hold Time		100		50		ns
t_{PD1}	Output Delay to 1			250		150	ns
t_{PD0}	Output Delay to 0	$C_L = 100\text{ pF}$ (Note 7)		250		150	ns
t_{HZ} (Note 8)	Output Delay to High–Z			150		100	ns
t_{EW}	Program/Erase Pulse Width			5		5	ms
t_{CSMIN}	Minimum CS Low Time		200		150		ns
t_{SKHI}	Minimum SK High Time		250		150		ns
t_{SKLOW}	Minimum SK Low Time		250		150		ns
t_{SV}	Output Delay to Status Valid			250		100	ns
SK_{MAX}	Maximum Clock Frequency		DC	1000	DC	3000	kHz

7. The input levels and timing reference points are shown in the “AC Test Conditions” table.

8. These parameters are tested initially and after a design or process change that affects the parameter.

Table 7. POWER–UP TIMING (Notes 8, 9)

Symbol	Parameter	Max	Units
t_{PUR}	Power–up to Read Operation	1	ms
t_{PUW}	Power–up to Write Operation	1	ms

9. t_{PUR} and t_{PUW} are the delays required from the time V_{CC} is stable until the specified operation can be initiated.

Table 8. A.C. TEST CONDITIONS

Input Rise and Fall Times	$\leq 50\text{ ns}$	
Input Pulse Voltages	0.4 V to 2.4 V	$4.5\text{ V} \leq V_{CC} \leq 5.5\text{ V}$
Timing Reference Voltages	0.8 V, 2.0 V	$4.5\text{ V} \leq V_{CC} \leq 5.5\text{ V}$
Input Pulse Voltages	$0.2 V_{CC}$ to $0.7 V_{CC}$	$1.8\text{ V} \leq V_{CC} \leq 4.5\text{ V}$
Timing Reference Voltages	$0.5 V_{CC}$	$1.8\text{ V} \leq V_{CC} \leq 4.5\text{ V}$

Device Operation

The CAT93C76 is a 8192-bit nonvolatile memory intended for use with industry standard microprocessors. The CAT93C76 can be organized as either registers of 16 bits or 8 bits. When organized as X16, seven 13-bit instructions control the read, write and erase operations of the device. When organized as X8, seven 14-bit instructions control the read, write and erase operations of the device. The CAT93C76 operates on a single power supply and will generate on chip, the high voltage required during any write operation.

Instructions, addresses, and write data are clocked into the DI pin on the rising edge of the clock (SK). The DO pin is normally in a high impedance state except when reading data from the device, or when checking the ready/busy status after a write operation.

The ready/busy status can be determined after the start of a write operation by selecting the device (CS high) and polling the DO pin; DO low indicates that the write operation is not completed, while DO high indicates that the device is ready for the next instruction. If necessary, the DO pin may be placed back into a high impedance state during chip select by shifting a dummy "1" into the DI pin. The DO pin will enter the high impedance state on the falling edge of the clock (SK). Placing the DO pin into the high impedance state is recommended in applications where the DI pin and the DO pin are to be tied together to form a common DI/O pin.

The format for all instructions sent to the device is a logical "1" start bit, a 2-bit (or 4-bit) opcode, 10-bit address (an additional bit when organized X8) and for write operations a 16-bit data field (8-bit for X8 organizations). The most significant bit of the address is "don't care" but it must be present.

Read

Upon receiving a READ command and an address (clocked into the DI pin), the DO pin of the CAT93C76 will come out of the high impedance state and, after sending an initial dummy zero bit, will begin shifting out the data addressed (MSB first). The output data bits will toggle on the rising edge of the SK clock and are stable after the specified time delay (t_{PD0} or t_{PD1}).

For the CAT93C76, after the initial data word has been shifted out and CS remains asserted with the SK clock continuing to toggle, the device will automatically increment to the next address and shift out the next data word in a sequential READ mode. As long as CS is continuously asserted and SK continues to toggle, the device will keep incrementing to the next address automatically until it reaches the end of the address space, then loops back to address 0. In the sequential READ mode, only the initial data word is preceded by a dummy zero bit. All subsequent data words will follow without a dummy zero bit.

Write

After receiving a WRITE command, address and the data, the CS (Chip Select) pin must be deselected for a minimum of t_{CSMIN} . The falling edge of CS will start the self clocking clear and data store cycle of the memory location specified in the instruction. The clocking of the SK pin is not necessary after the device has entered the self clocking mode. The ready/busy status of the CAT93C76 can be determined by selecting the device and polling the DO pin. Since this device features Auto-Clear before write, it is NOT necessary to erase a memory location before it is written into.

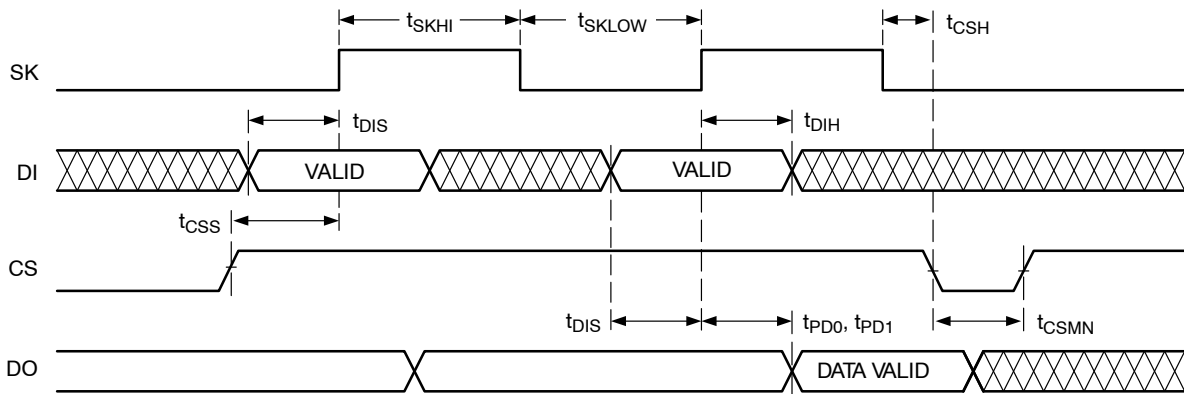

Figure 2. Synchronous Data Timing

CAT93C76

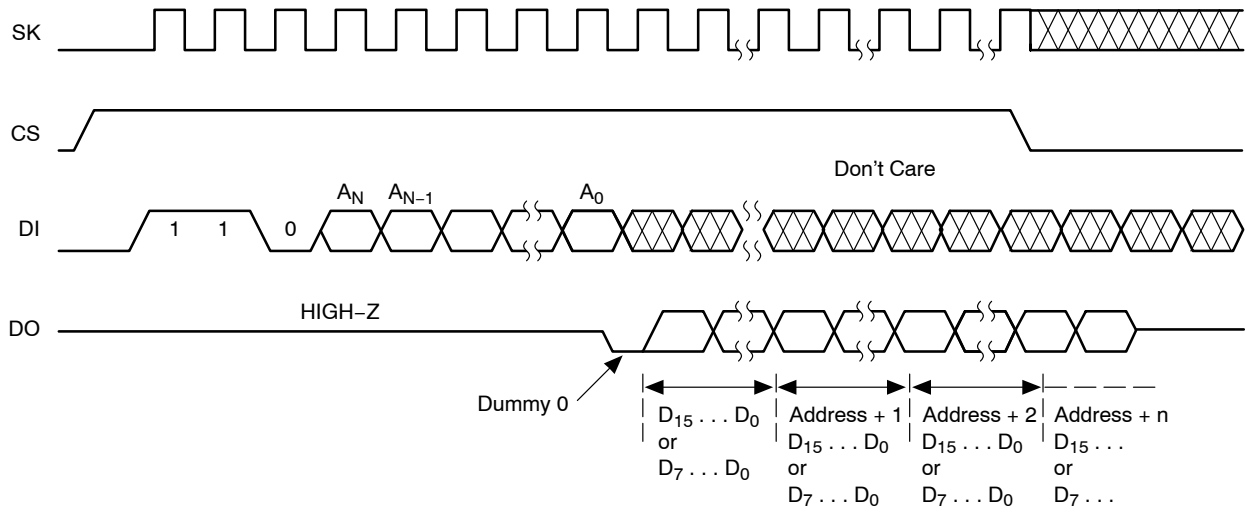

Figure 3. READ Instruction Timing

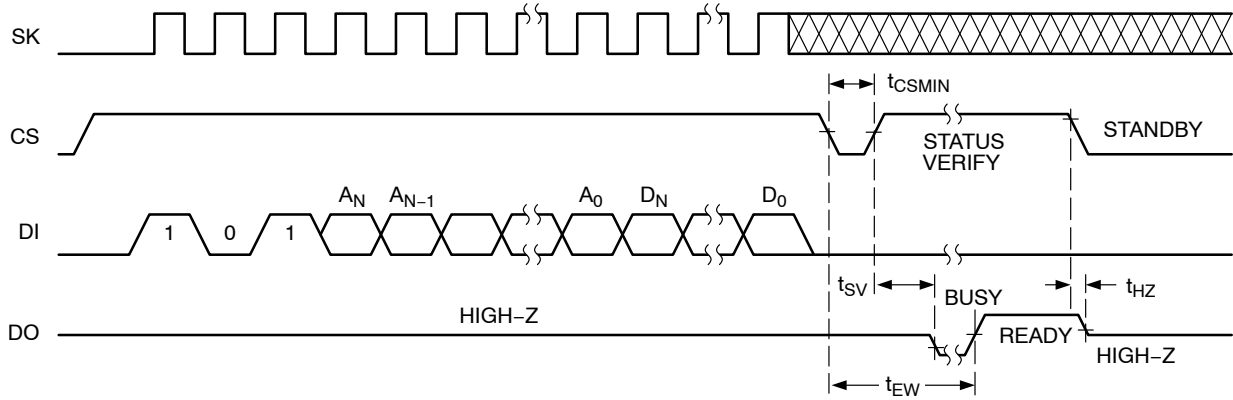

Figure 4. WRITE Instruction Timing

CAT93C76

Erase

Upon receiving an ERASE command and address, the CS (Chip Select) pin must be deasserted for a minimum of t_{CSMIN} . The falling edge of CS will start the self clocking clear cycle of the selected memory location. The clocking of the SK pin is not necessary after the device has entered the self clocking mode. The ready/busy status of the CAT93C76 can be determined by selecting the device and polling the DO pin. Once cleared, the content of a cleared location returns to a logical “1” state.

Erase/Write Enable and Disable

The CAT93C76 powers up in the write disable state. Any writing after power-up or after an EWDS (write disable) instruction must first be preceded by the EWEN (write enable) instruction. Once the write instruction is enabled, it will remain enabled until power to the device is removed, or the EWDS instruction is sent. The EWDS instruction can be used to disable all CAT93C76 write and clear instructions, and will prevent any accidental writing or clearing of the device. Data can be read normally from the device regardless of the write enable/disable status.

Erase All

Upon receiving an ERAL command, the CS (Chip Select) pin must be deselected for a minimum of t_{CSMIN} . The falling edge of CS will start the self clocking clear cycle of all memory locations in the device. The clocking of the SK pin is not necessary after the device has entered the self clocking mode. The ready/busy status of the CAT93C76 can be

determined by selecting the device and polling the DO pin. Once cleared, the contents of all memory bits return to a logical “1” state.

Write All

Upon receiving a WRAL command and data, the CS (Chip Select) pin must be deselected for a minimum of t_{CSMIN} . The falling edge of CS will start the self clocking data write to all memory locations in the device. The clocking of the SK pin is not necessary after the device has entered the self clocking mode. The ready/busy status of the CAT93C76 can be determined by selecting the device and polling the DO pin. It is not necessary for all memory locations to be cleared before the WRAL command is executed.

Note 1: After the last data bit has been sampled, Chip Select (CS) must be brought Low before the next rising edge of the clock (SK) in order to start the self-timed high voltage cycle. This is important because if CS is brought low before or after this specific frame window, the addressed location will not be programmed or erased.

Power-On Reset (POR)

The CAT93C76 incorporates Power-On Reset (POR) circuitry which protects the device against malfunctioning while V_{CC} is lower than the recommended operating voltage.

The device will power up into a read-only state and will power-down into a reset state when V_{CC} crosses the POR level of ~1.3 V.

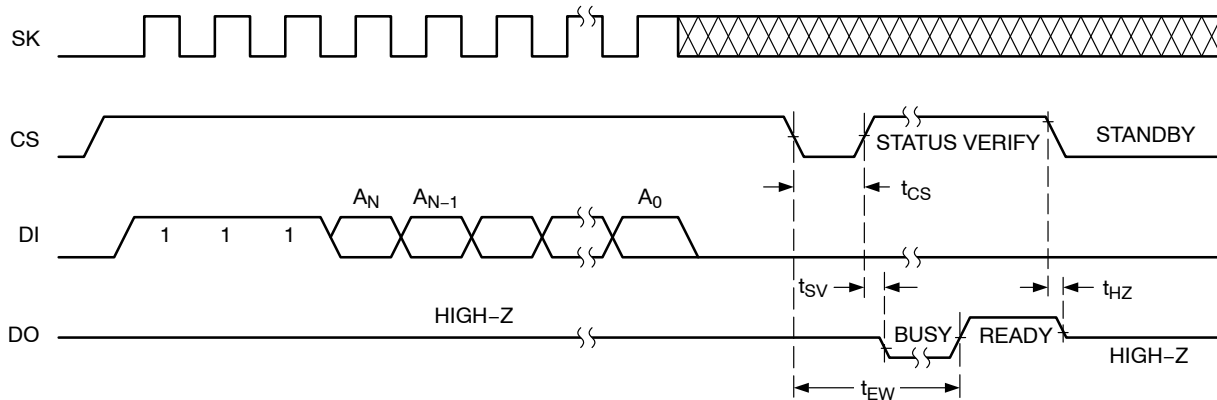

Figure 5. ERASE Instruction Timing

CAT93C76

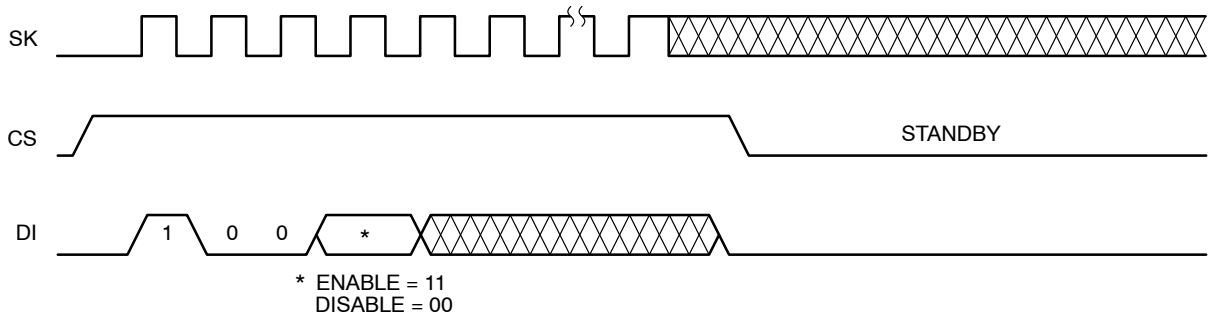

Figure 6. EWEN/EWDS Instruction Timing

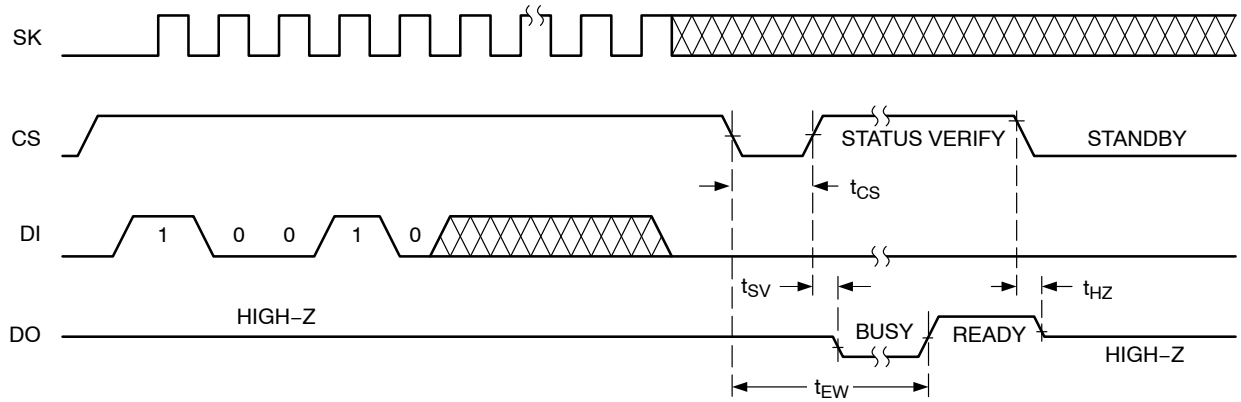

Figure 7. ERAL Instruction Timing

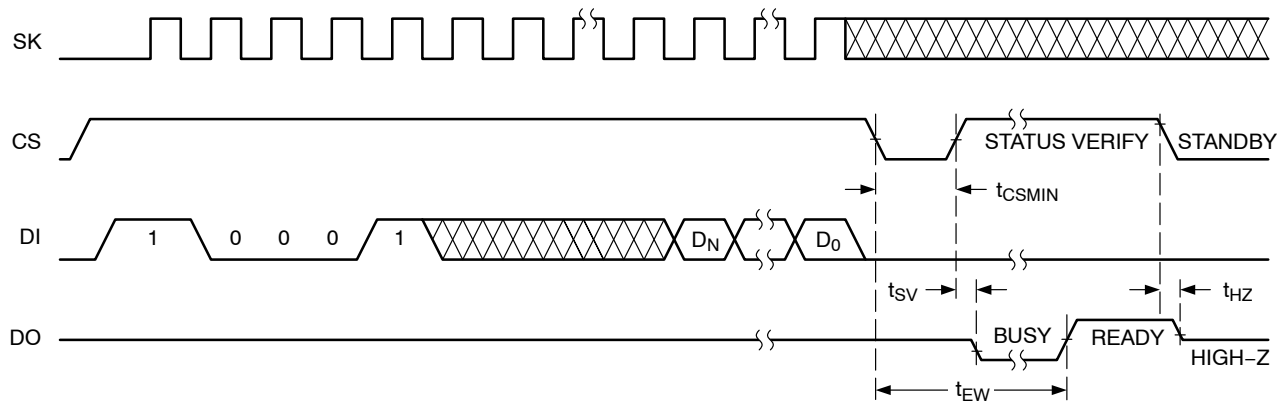
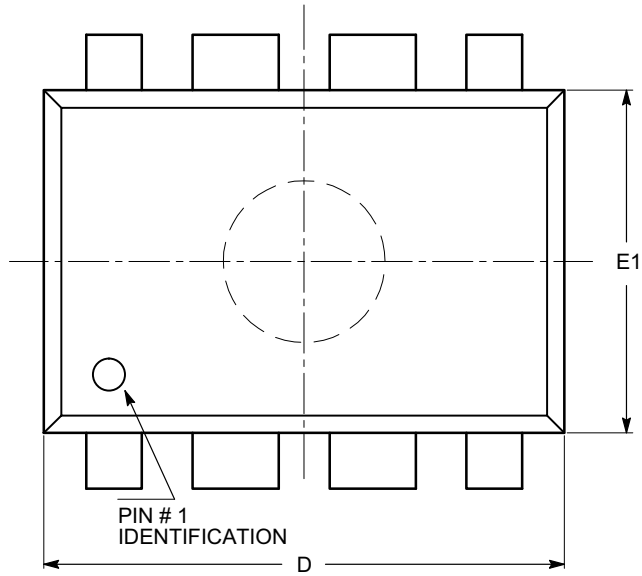

Figure 8. WRAL Instruction Timing

CAT93C76

PACKAGE DIMENSIONS

PDIP-8, 300 mils
CASE 646AA-01
ISSUE A



SYMBOL	MIN	NOM	MAX
A			5.33
A1	0.38		
A2	2.92	3.30	4.95
b	0.36	0.46	0.56
b2	1.14	1.52	1.78
c	0.20	0.25	0.36
D	9.02	9.27	10.16
E	7.62	7.87	8.25
E1	6.10	6.35	7.11
e	2.54 BSC		
eB	7.87		10.92
L	2.92	3.30	3.80

TOP VIEW

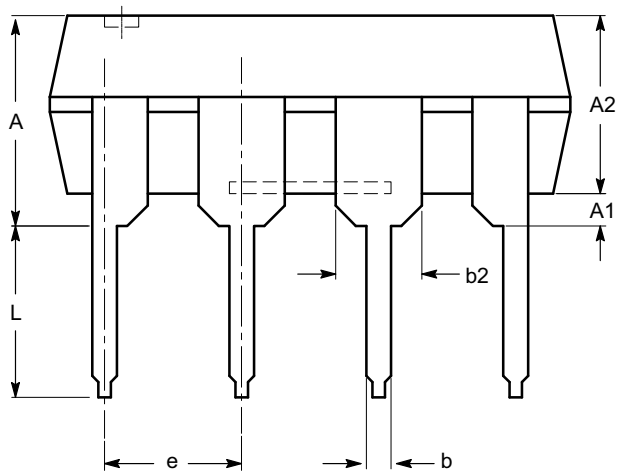

SIDE VIEW

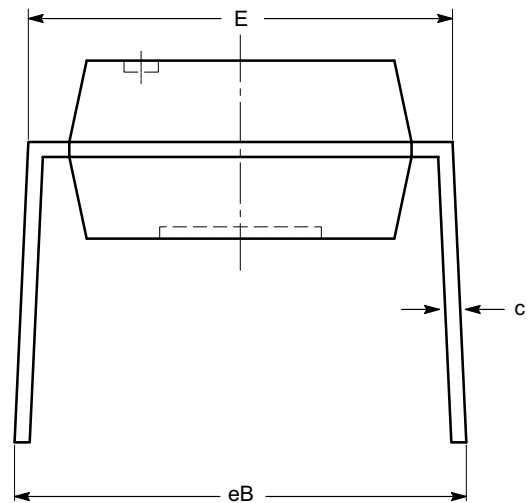

END VIEW

Notes:

- (1) All dimensions are in millimeters.
- (2) Complies with JEDEC MS-001.

CAT93C76

PACKAGE DIMENSIONS

SOIC 8, 150 mils
CASE 751BD-01
ISSUE O

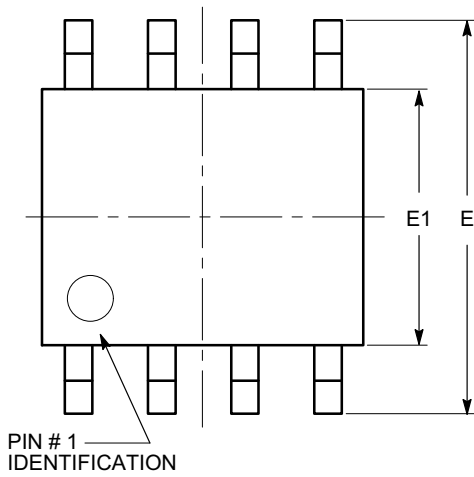

TOP VIEW

SYMBOL	MIN	NOM	MAX
A	1.35		1.75
A1	0.10		0.25
b	0.33		0.51
c	0.19		0.25
D	4.80		5.00
E	5.80		6.20
E1	3.80		4.00
e	1.27 BSC		
h	0.25		0.50
L	0.40		1.27
θ	0°		8°

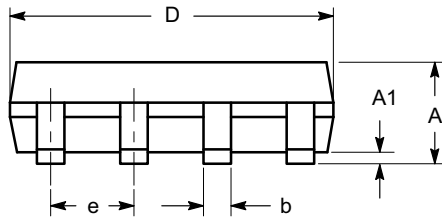

SIDE VIEW

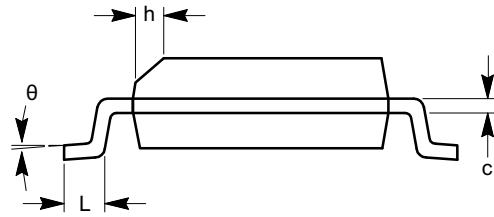

END VIEW

Notes:

- (1) All dimensions are in millimeters. Angles in degrees.
- (2) Complies with JEDEC MS-012.

CAT93C76

PACKAGE DIMENSIONS

TSSOP8, 4.4x3
CASE 948AL-01
ISSUE O

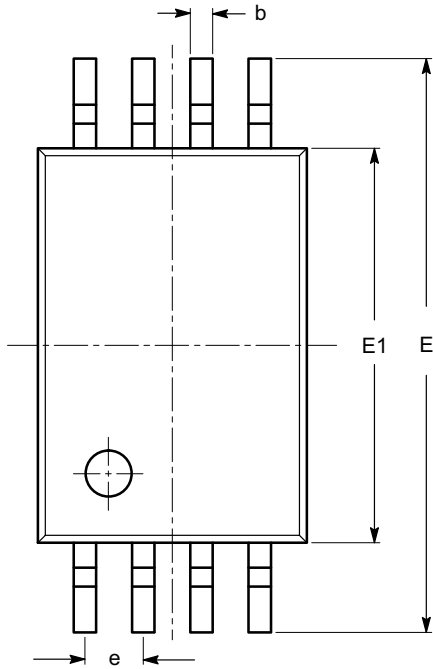

SYMBOL	MIN	NOM	MAX
A			1.20
A1	0.05		0.15
A2	0.80	0.90	1.05
b	0.19		0.30
c	0.09		0.20
D	2.90	3.00	3.10
E	6.30	6.40	6.50
E1	4.30	4.40	4.50
e	0.65 BSC		
L	1.00 REF		
L1	0.50	0.60	0.75
θ	0°		8°

TOP VIEW

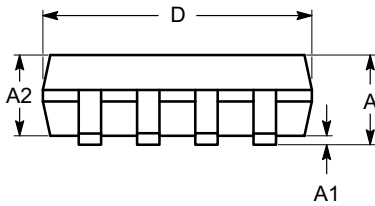

SIDE VIEW

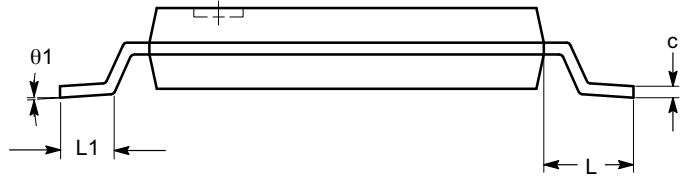

END VIEW

Notes:

- (1) All dimensions are in millimeters. Angles in degrees.
- (2) Complies with JEDEC MO-153.

CAT93C76

PACKAGE DIMENSIONS

TDFN8, 3x3
CASE 511AL-01
ISSUE A

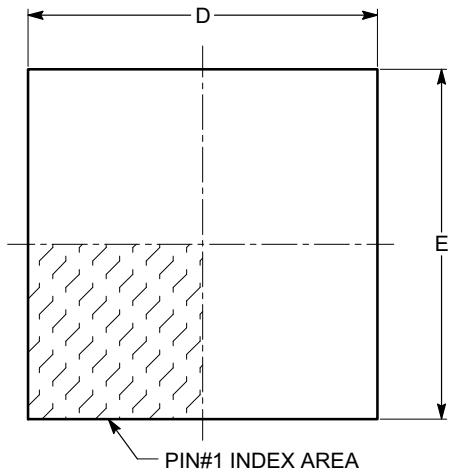

TOP VIEW

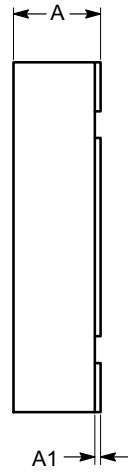

SIDE VIEW

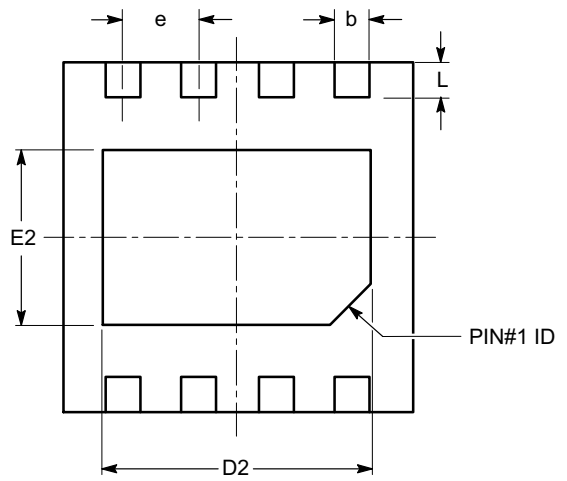

BOTTOM VIEW

SYMBOL	MIN	NOM	MAX
A	0.70	0.75	0.80
A1	0.00	0.02	0.05
A3	0.20 REF		
b	0.23	0.30	0.37
D	2.90	3.00	3.10
D2	2.20	---	2.50
E	2.90	3.00	3.10
E2	1.40	---	1.80
e	0.65 TYP		
L	0.20	0.30	0.40

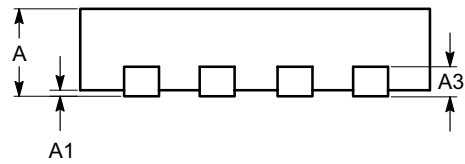

FRONT VIEW

Notes:

- (1) All dimensions are in millimeters.
- (2) Complies with JEDEC MO-229.

CAT93C76

Example of Ordering Information

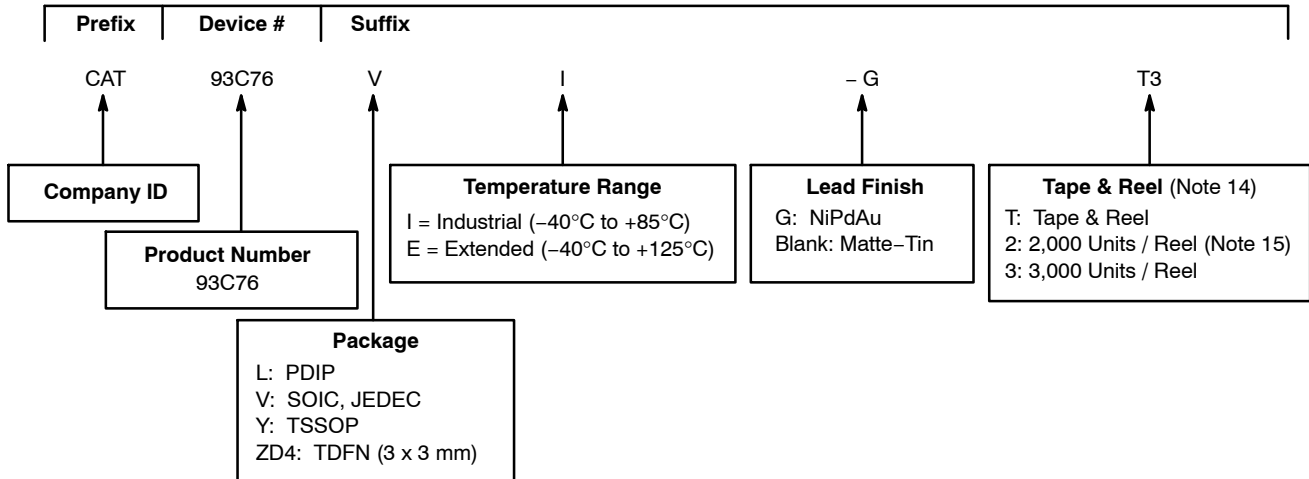

10. All packages are RoHS-compliant (Lead-free, Halogen-free).
11. The standard lead finish is NiPdAu.
12. The device used in the above example is a CAT93C76VI-GT3 (SOIC, Industrial Temperature, NiPdAu, Tape & Reel, 3,000 / Reel).
13. Product die revision letter is marked on top of the package as a suffix to the production date code (e.g., AYWWA). For additional information, please contact your ON Semiconductor sales office.
14. For information on tape and reel specifications, including part orientation and tape sizes, please refer to our Tape and Reel Packaging Specifications Brochure, BRD8011/D.
15. For TDFN 3 x 3 mm package Tape and Reel = 2,000 / Reel, all others = 3,000 / Reel.
16. For additional package and temperature options, please contact your nearest ON Semiconductor sales office.

ON Semiconductor and  are registered trademarks of Semiconductor Components Industries, LLC (SCILLC). SCILLC reserves the right to make changes without further notice to any products herein. SCILLC makes no warranty, representation or guarantee regarding the suitability of its products for any particular purpose, nor does SCILLC assume any liability arising out of the application or use of any product or circuit, and specifically disclaims any and all liability, including without limitation special, consequential or incidental damages. "Typical" parameters which may be provided in SCILLC data sheets and/or specifications can and do vary in different applications and actual performance may vary over time. All operating parameters, including "Typicals" must be validated for each customer application by customer's technical experts. SCILLC does not convey any license under its patent rights nor the rights of others. SCILLC products are not designed, intended, or authorized for use as components in systems intended for surgical implant into the body, or other applications intended to support or sustain life, or for any other application in which the failure of the SCILLC product could create a situation where personal injury or death may occur. Should Buyer purchase or use SCILLC products for any such unintended or unauthorized application, Buyer shall indemnify and hold SCILLC and its officers, employees, subsidiaries, affiliates, and distributors harmless against all claims, costs, damages, and expenses, and reasonable attorney fees arising out of, directly or indirectly, any claim of personal injury or death associated with such unintended or unauthorized use, even if such claim alleges that SCILLC was negligent regarding the design or manufacture of the part. SCILLC is an Equal Opportunity/Affirmative Action Employer. This literature is subject to all applicable copyright laws and is not for resale in any manner.

PUBLICATION ORDERING INFORMATION

LITERATURE FULFILLMENT:
Literature Distribution Center for ON Semiconductor
P.O. Box 5163, Denver, Colorado 80217 USA
Phone: 303-675-2175 or 800-344-3860 Toll Free USA/Canada
Fax: 303-675-2176 or 800-344-3867 Toll Free USA/Canada
Email: orderlit@onsemi.com

N. American Technical Support: 800-282-9855 Toll Free
USA/Canada
Europe, Middle East and Africa Technical Support:
Phone: 421 33 790 2910
Japan Customer Focus Center
Phone: 81-3-5773-3850

ON Semiconductor Website: www.onsemi.com
Order Literature: <http://www.onsemi.com/orderlit>
For additional information, please contact your local Sales Representative