

Description

The Si4706 is a 100% CMOS receiver integrated circuit (IC), offering the full receive functionality from antenna to RDS/RBDS data for use as a dedicated data receiver. It is an ideal RDS/RBDS data receiver for Traffic Message Channel (TMC) and Open Data Applications (ODA) applications frequently used in conjunction with GPS functionality. It offers a fully-integrated decoder for the European RDS* and the North American RBDS. It includes demodulation, symbol decoding, advanced error correction, detailed visibility to block-error rates (BLER), and decoder reliability, synchronization status, and times. The Si4706 provides complete, decoded, and error-corrected RDS groups, up to 25 groups at a time in four 16-bit registers.

The Si4706 incorporates a high performance RDS decoder based on patented methodologies and delivers excellent RDS sensitivity performance, synchronization to RDS at high BLER levels, and RDS data decoding with superior decoder reliability.

The Si4706 draws on Silicon Laboratories' broadcast audio and corresponding patent portfolio using a digital low intermediate frequency (low-IF) receiver architecture proven by over 100 million broadcast audio receivers shipped worldwide. The low-IF architecture allows the Si4706 to deliver superior performance while integrating the great majority of external components required by competing solutions.

The Si4706 is the first FM radio receiver integrated circuit to support an embedded antenna, which can be integrated into the enclosure or PCB of a portable device. For portable navigation devices, the Si4706 embedded antenna feature permits integration of the traffic messaging antenna into the enclosure of the portable device and eliminates the need for external

antenna cables.

The Si4706 is feature-rich, providing both highly automated performance, according to Silicon Laboratories' recommended settings, and extensive programmability and flexibility for customized system performance.

***Note:** The term "RDS" will be used to mean "RDS/RBDS" throughout this document.

Features

- Worldwide FM band support (76–108 MHz)
- Advanced RDS decoding engine
- Unmatched RDS sensitivity
- Leading RDS synchronization metrics
- Highly reliable RDS decode
- RDS reception with FM mono broadcast
- Received signal quality indicators
- Supports integrated antenna
- Automatic gain control (AGC)
- Integrated FM LNA
- Image-rejection mixer
- Frequency synthesizer with integrated VCO
- Low-IF direct conversion with no external ceramic filters
- 2.7 to 5.5 V supply voltage
- Programmable reference clock
- 20-pin 3 x 3 mm QFN package
- Pb-free/RoHS compliant
- Stereo audio OUT
- I²S Digital audio OUT

Applications

- Personal navigation devices (PND)
- Dedicated data receiver
- GPS-enabled portable devices

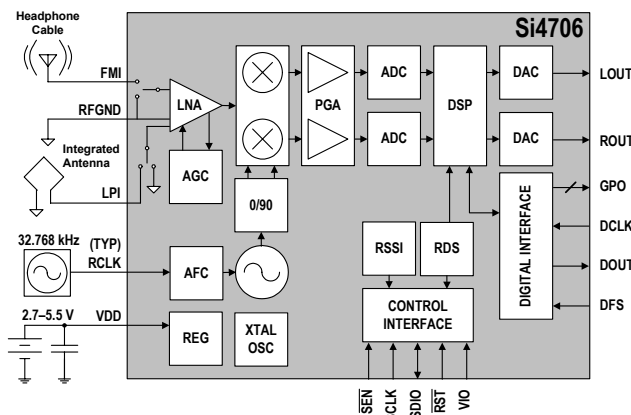

Selected Electrical Specifications

Parameter	Test Condition	Min	Typ	Max	Unit
Input Frequency		76		108	MHz
Frequency Steps		10		200	kHz
RDS Sensitivity	$\Delta f = 2$ kHz, RDS BLER < 5%		8		μ V emf
Input IP3	400 and 800 kHz blockers		99		dB μ V emf
Image Rejection			55		dB
Adjacent Channel Selectivity	± 200 kHz		50		dB
Alternate Channel Selectivity	± 400 kHz		70		dB
Audio Mono S/N		55	63	—	dB
Audio THD		—	0.1	0.5	%
RCLK Frequency		31.13	32.768	40,000	kHz
RCLK Tolerance		-100		100	ppm
Supply Voltage		3		5.5	V
Interface Supply Voltage		1.5		3.6	V
Supply Current			22		mA
Ambient Temperature		-20		85	C
Seek/Tune Time	RCLK tolerance = 100 ppm			60	ms/channel
Powerup Time	From powerdown			110	ms

Pin Assignments

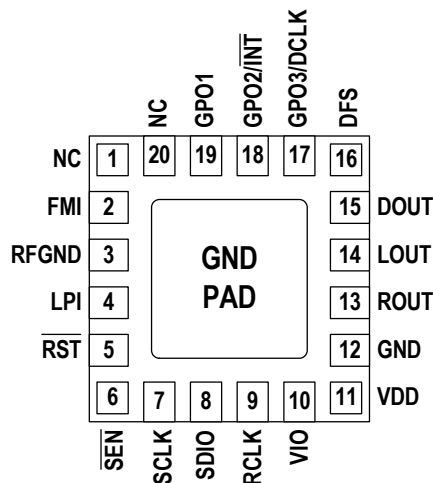

Package Information

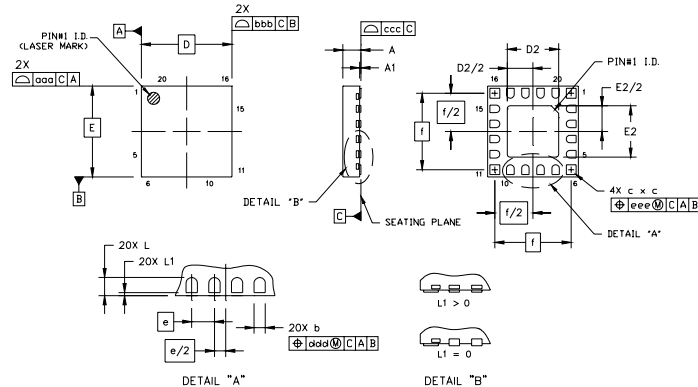

Symbol	Millimeters		
	Min	Nom	Max
A	0.50	0.55	0.60
A1	0.00	0.02	0.05
b	0.18	0.25	0.30
c	0.27	0.32	0.37
D	3.00 BSC		
D2	1.60	1.70	1.80
e	0.50 BSC		
E	3.00 BSC		
E2	1.60	1.70	1.80

Symbol	Millimeters		
	Min	Nom	Max
f	2.53 BSC		
L	0.35	0.40	0.45
L1	0.00	—	0.10
aaa	—	—	0.10
bbb	—	—	0.10
ccc	—	—	0.08
ddd	—	—	0.10
eee	—	—	0.10

Notes:

- All dimensions are shown in millimeters unless otherwise noted.
- Dimensioning and tolerancing per ANSI Y14.5M-1994.