

C-BUNDLE-ARK1122-3

C-BUNDLE-ARK1122-4

15" Intel® Atom™ N2600 Modular Fanless Panel PC

NEW



Panel Mount Modular Panel PC



Open Frame Modular Panel PC

Features

- Intel® Atom® N2600 Dual Core 1.6GHz. support up to 720p @ 60 fps video playback
- 4 GB DDR3 memory & 1 x 16G SSD (mSATA)
- 15" XGA, 400nits LCD backlight with 5-wire resistive touch
- 1 x HDMI, 1 x GbE, 1 x RS232, 3 x USB 2.0 Line in, Line out
- Optional WLAN and mSATA storage module
- Open frame/Panel mount and VESA mount compliance

Specifications

		C-BUNDLE-ARK1122-3 15" Open Frame Modular Panel PC	C-BUNDLE-ARK1122-4 15" Panel Mount Modular Panel PC
System	CPU	Intel Atom Dual Core N2600 1.6 GHz	
	BIOS	AMI EFI 16 Mbit	
	Memory	DDR3-1333 MHz 4 GB, non-ECC	
	Chipset	Intel Atom N2600	
	I/O	1 x HDMI, 1 x GbE, 1 x RS232, 4 x USB*, 1 x VGA* *1 x VGA and 1 x USB are occupied by 15" monitor	
	Storage	1 x 2.5" SATA hard drive bay (HDD is optional) 1 x Full-size 16G mSATA (MLC)	
	Expansions	1 x Half-size Mini PCIe (ex. WIFI module)	
	Audio	Realtek ALC892, High Definition Audio (HD), Line-In & Line-Out	
	Power Input Voltage	12 V _{DC}	
	Software Support	WIN 7 , WES7 (Optional)	
	Operating Temp	-20 ~ 60° C	
	Storage Temp	-40 ~ 85° C	
Regulation	CE,FCC,CB,UL,CCC,BSMI		
Monitor	Display Size	15"	
	Max. Resolution	1024 x 768 (XGA)	
	Brightness	400 (cd/m ²), LED backlight	
	Viewing Angle	80°/80° (H), 70°/70° (V)	
	Color Support	16.2M / 262k colors	
	Contrast Ratio	700:1	
	Response Time	25 [msec]	
	Backlight Life (hrs)	50,000 hrs	
	Power Input Voltage	12 V _{DC}	
	OSD	Keys: Menu,Up,Down,Auto Adjust, Monitor Power on/off Menu Functions: Brightness, Contrast, Screen Setting,Color Temp, Language	
	Operating temp	-20 ~ 60° C	
	Storage Temp	-30 ~ 70° C	
Regulation	CE,FCC,CCC		
Touchscreen	Surface Hardness	3H	
	Durability	10 million touches	
	Transparency	80% ± 3%	
Mechanical	Dimensions (W x H x D)	362.0 x 288.0 x 93.2 mm (14.11" x 11.23" x 3.62") (With Top Mounting kit)	365.0 x 291.0 x 95.5 mm (14.23" x 11.34" x 3.72") (With Top Mounting kit)
		362.0 x 288.0 x 91.2 mm (14.11" x 11.23" x 3.55") (Without Top Mounting kit)	365.0 x 291.0 x 93.5 mm (14.23" x 11.34" x 3.64") (Without Top Mounting kit)
	Mounting	VESA mount compliance	

15" Intel® Atom™ N2600 Modular Fanless Panel PC

Dimensions

Unit: mm

Open Frame

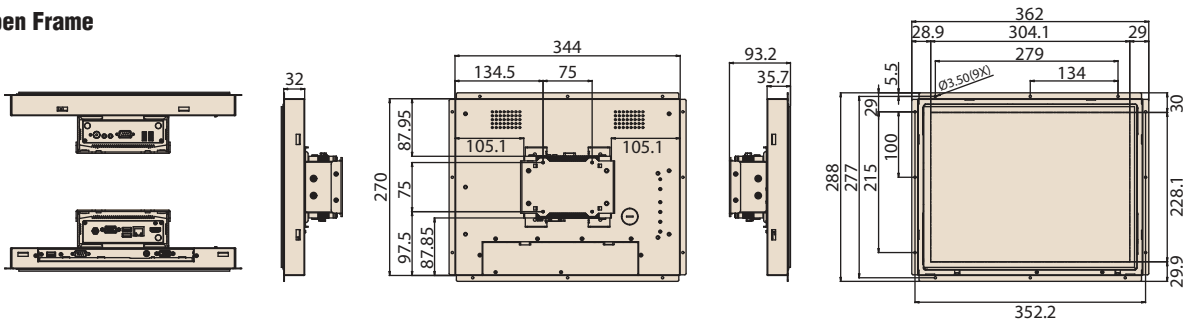

Panel Mount

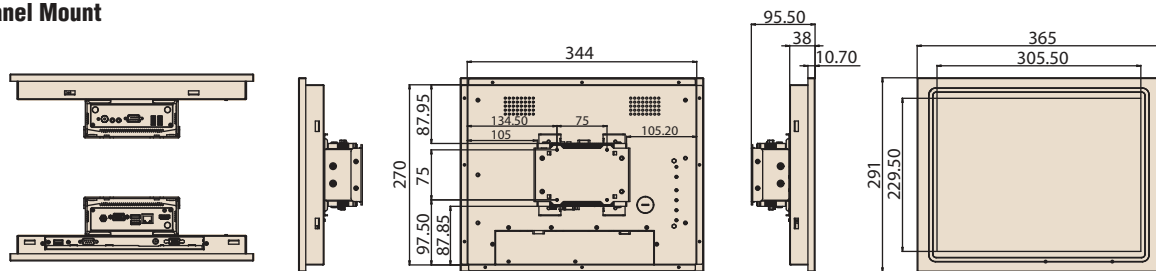

Packing List

Part Number	Description
C-BUNDLE-ARK1122-3	1 x 15" Open Frame TFT LCD + ARK-1122H + Accessories (See below)
1757004096-01	2x AC/DC adapter DC12V 36W, 0 ~ 40° C
1700023273-01	1 x 15cm VGA cable
1700022248-02	1 x 15cm USB cable
1960064275N101	2 x side mounting kit
1960064278N001	1 x top mounting kit
-	Mounting screws, clampers, cable ties
C-BUNDLE-ARK1122-4	1 x 15" Panel Mount TFT LCD + ARK-1122H + Accessories (See below)
1757004096-01	2x AC/DC adapter DC12V 36W, 0 ~ 40° C
1700023273-01	1 x 15cm VGA cable
1700022248-02	1 x 15cm USB cable
1960064275N101	2 x side mounting kit
1960064278N001	1 x top mounting kit
-	Mounting screws, clampers, cable ties

Front I/O

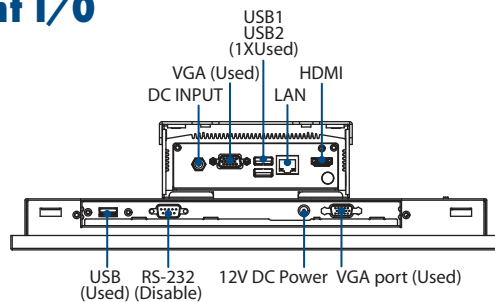

Rear I/O

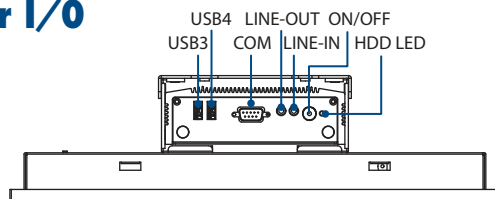

Optional Items

Part Number	Description
1960063019N001	Mounting Adapter (75mm to 100mm)
1700001524	Power Cable 3-pin 180cm, USA type
170203183C	Power Cable 3-pin 180cm, Europe type
170203180A	Power Cable 3-pin 180cm, UK type

Embedded OS

Part Number	Description
2070011879	WES7, English version w/ 32bits

Back View

