

LOC		DIST		REVISIONS			
P	LTR	DESCRIPTION	DATE	DMN	APVD		
H	REV PER ECO	15-005929	5-12-15	CT	DM		

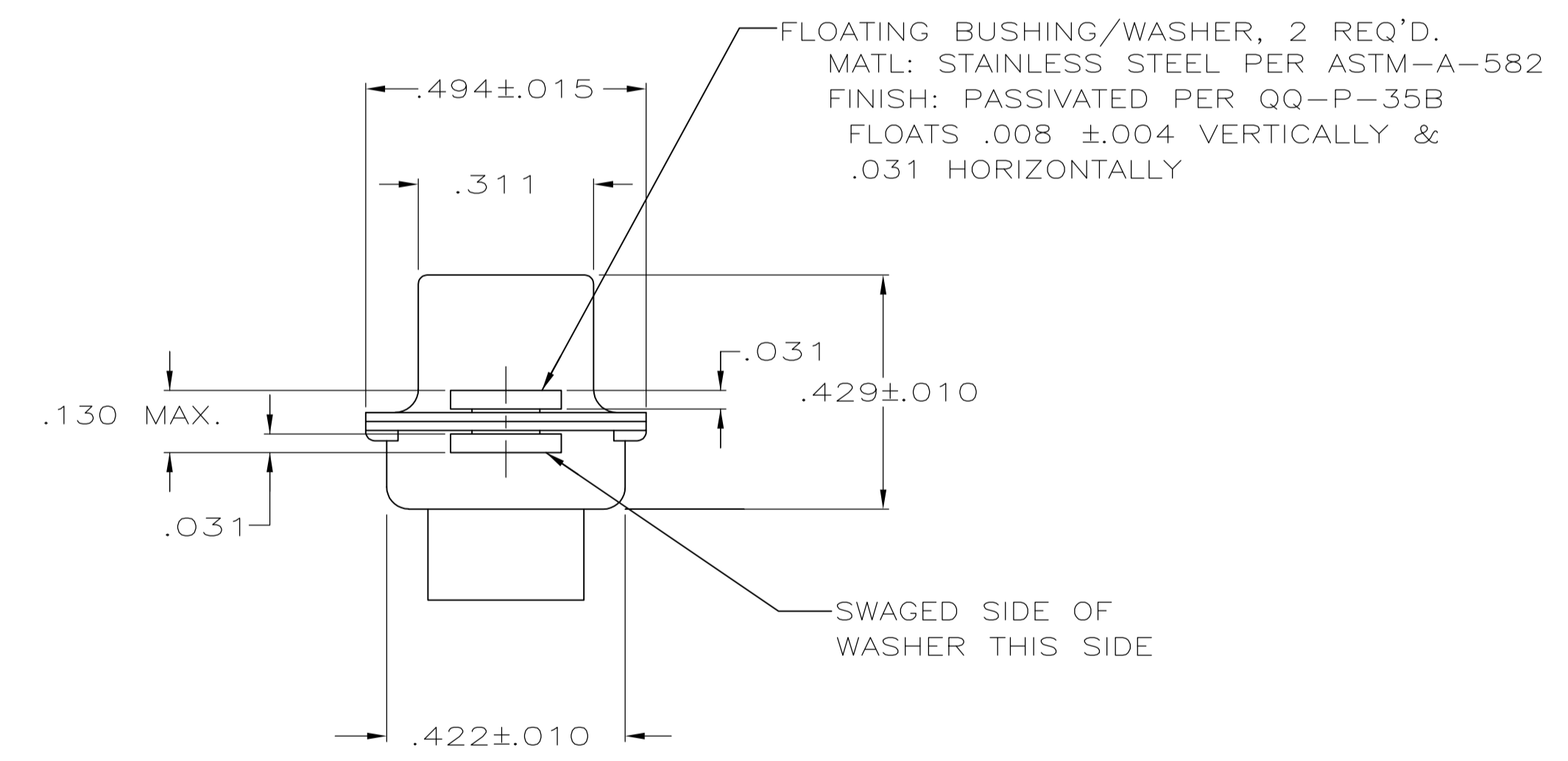
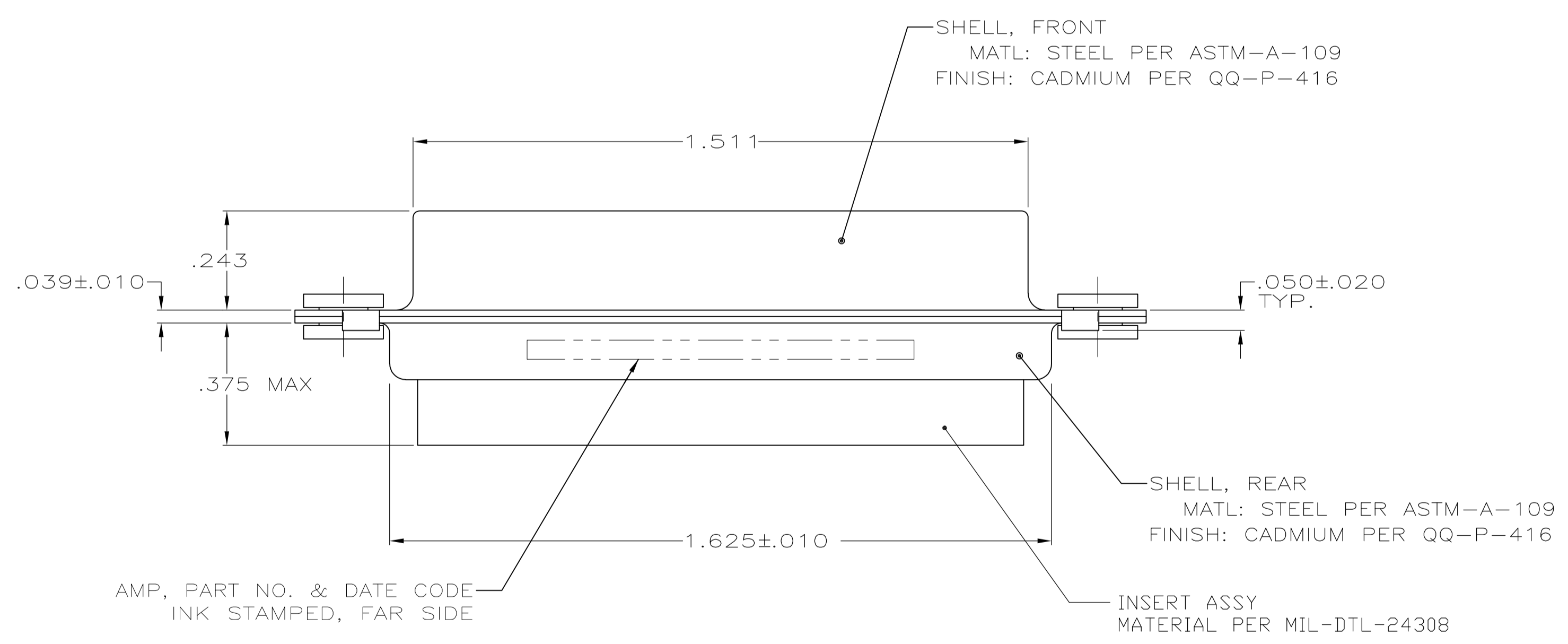
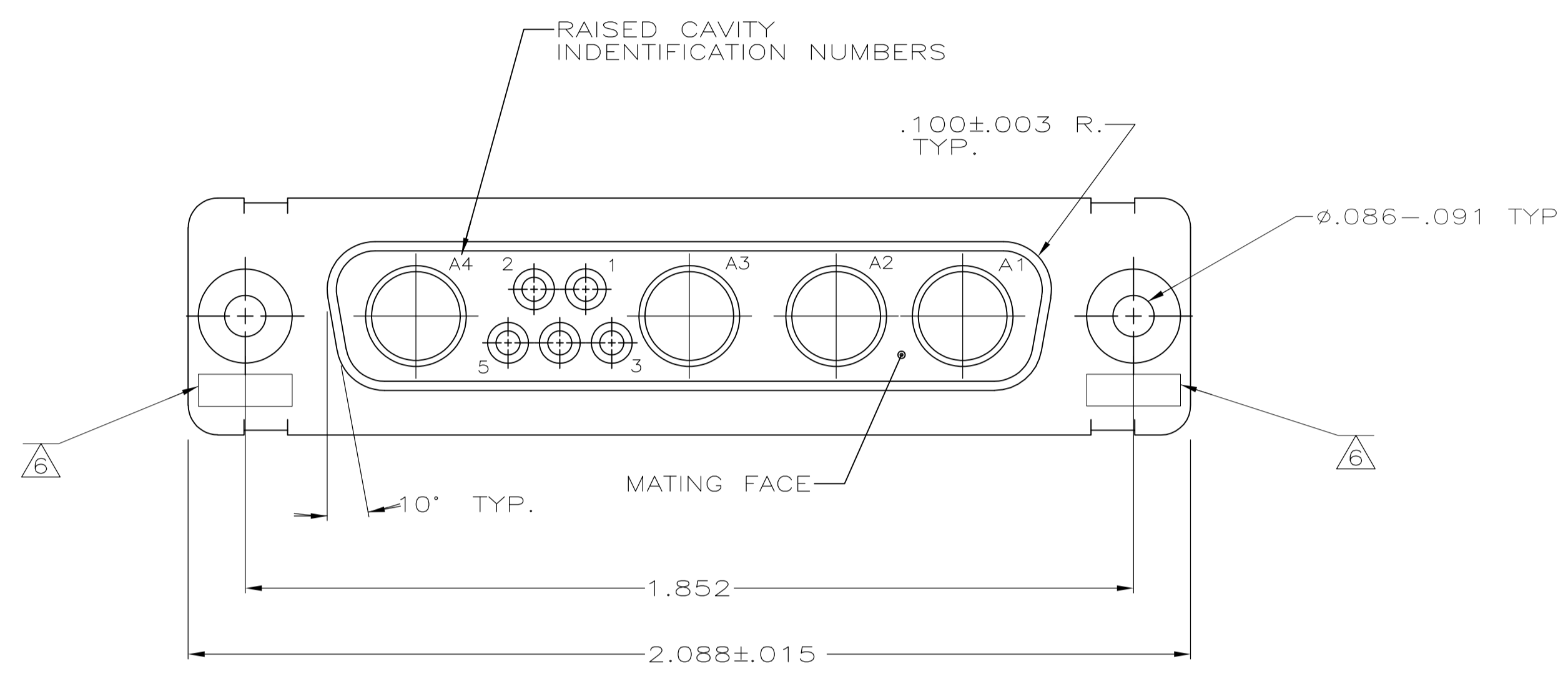

- THIS RECEPTACLE WILL MATE WITH ANY 9C4, SIZE 3 PLUG IN AMPLIMITE SERIES.
- MAXIMUM WIRE INSULATION TO BE USED WITH THIS RECEPTACLE IS  $.068$  DIA.
- STAINLESS STEEL RETENTION CLIPS (5) ARE INCLUDED IN INSERT ASSEMBLY.
- CONNECTOR SUPPLIED WITH (6) SIGNAL SOCKET CONTACTS; PACKAGED IN A SEPERATE BAG.
- USE 4 SIZE 8 POWER OR COAX SOCKET CONTACTS. CONSULT PRODUCT ENGINEERING FOR MORE DETAILS
- UL/CSA DESIGNATION STAMPED IN THIS AREA, OPTIONAL.
- MATING FACE SIZE 8 PORTS CHAMFERED TO ACCOMODATE BLINDMATE APPLICATION. BLIND MATE PLUG 445701-1 WILL MATE WITH THIS CONNECTOR.

7	212051-2
4	212051-1
REMARKS	PART NO.

THIS DRAWING IS A CONTROLLED DOCUMENT.		DIN C.C.THOMAS 2-3-88	STE TE Connectivity	
DIMENSIONS: INCHES		CHK A.F.MADI 2-8-88	NAME	
TOLERANCES UNLESS OTHERWISE SPECIFIED:		APVD A.F.MADI 2-8-88	PRODUCT SPEC	
0 PLC ± -		APPLICATION SPEC		
1 PLC ± -		SIZE CAGE CODE DRAWING NO		
2 PLC ± -		WEIGHT		
3 PLC ± .005		A1 00779 C=212051		
4 PLC ± -		CUSTOMER DRAWING		
ANGLES ± -		SCALE 4:1 SHEET 1 OF 1 REV H		
FINISH SEE CALLOUTS				