

PART NUMBER	REVISION	DESCRIPTION	FEED TYPE
2151072-1	F	FINE CRIMP HEIGHT ADJUST	MECHANICAL
2151072-2	F	FINE CRIMP HEIGHT ADJUST	PNEUMATIC
7-2151072-1	F	MECHANICAL AND CRIMP TOOLING KIT	MECHANICAL
7-2151072-2	F	PNEUMATIC AND CRIMP TOOLING KIT	PNEUMATIC
7-2151072-7	E	CRIMP TOOLING KIT	-

ATLANTIC VERSION TERMINATOR INTERFACE ADAPTER

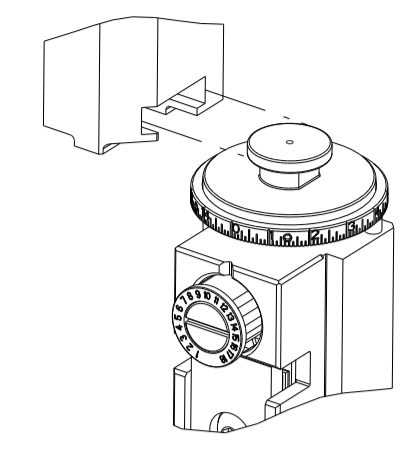

APPLICATOR DATA		
CRIMP	SIZE	TYPE
WIRE	1.40 mm [.055]	F
INSUL	2.75 mm [.108]	F

APPLICATOR INSTRUCTIONS  
408-35042

TERMINAL DATA: TE TERMINAL		TE CRIMP SPECIFICATION	
TERMINAL NAME: AMP POWER DBL LOCK CONN, REC. CONTACT			
WIRE STRIP LENGTH		INSULATION DIAMETER RANGE	
3.00-4.00 mm [.118-.157 IN]		Ø1.30-2.00 mm [.051-.079 IN]	
TERMINAL APPLICATION SPECIFICATION	(A)114-5175		
TERMINALS APPLIED			
TE TERMINAL	TE TERMINAL	TE TERMINAL	TE TERMINAL
(A) 177914-1	(A) 177914-2	(A) 177916-1	(A) 1-177916-1
(A) 5-177916-1	(A) 2369502		

TERMINAL DATA: TE TERMINAL		TE CRIMP SPECIFICATION	
TERMINAL NAME: AMP POWER DBL LOCK CONN, REC. CONTACT			
WIRE STRIP LENGTH		INSULATION DIAMETER RANGE	
3.00-4.00 mm [.118-.157 IN]		Ø1.30-2.00 mm [.051-.079 IN]	
TERMINAL APPLICATION SPECIFICATION	114-61016		
TERMINALS APPLIED			
TE TERMINAL	TE TERMINAL	TE TERMINAL	TE TERMINAL
1743728-1			

WIRE SIZE	CRIMP HEIGHT mm [INCH]	CRIMP HEIGHT REFERENCE SETTING
0.51mm2 OR 20 AWG	0.98+/-0.05 [.039+/- .002]	7.5
0.34mm2 OR 22 AWG	0.89+/-0.05 [.035+/- .002]	8.4
0.22mm2 OR 24 AWG	0.85+/-0.05 [.033+/- .002]	8.8
0.14mm2 OR 26 AWG	0.80+/-0.05 [.031+/- .002]	9.4

- RECOMMENDED SPARE PARTS
- REFER TO SUPPLIED INSTRUCTION SHEET FOR CLEANING, LUBRICATION AND STORAGE OF APPLICATOR.
- APPLY PART NUMBER 1-23419-5 LOCTITE TO THREADS OF ITEM 50. APPLY PART NUMBER 2-23419-6 LOCTITE TO THREADS OF ITEM 242.
- CRIMP HEIGHT REFERENCE SETTING WAS THE SETTING USED WHEN THE APPLICATOR WAS QUALIFIED AT THE FACTORY. ADJUSTMENT MAY BE NECESSARY WHEN RUNNING APPLICATOR IN THE FIELD.
- TERMINAL LUBRICANT IS RECOMMENDED.
- 6. UNLESS SPECIFIED OTHERWISE TORQUE VALUES SHALL BE USED PER DOCUMENT, 101-35000.
- INSULATION DIAMETER RANGE FOR 22 AWG WIRE IS Ø2.2MM [.087IN].

**\*WARNING**  
ON INSTALLATION, SET WIRE DISC TO CRIMP HEIGHT REFERENCE SETTING FOR LARGEST WIRE SIZE. CRIMP HEIGHT REFERENCE SETTINGS GREATER THAN THE VALUE SHOWN MAY CAUSE DAMAGE TO THE CRIMP TOOLING. REFER TO THE INSTRUCTION SHEET FOR PROPER SETUP AND ADJUSTMENTS.

ATLANTIC VERSION  
Shown on sheets 1 of 4 & 2 of 4  
(Pacific version shown on sheets 3 of 4 & 4 of 4)

LOC	DIST	REVISIONS			
A	66	REV	DATE	BY	CHK
		D	ECR-18-006525	03MAY2018	YY JDG
		E	ECR-19-000451	10JAN2019	TB CT
		E1	ECR-19-009642	19JUN2019	TB TE
		F	ECR-21-006584	29JUN2021	FJ RK

-	1	-	1	-	2119641-1	FEED CAM, AIR FEED	248
-	1	1	1	1	2119082-9	CAM, SNAIL, INSULATION ADJUSTMENT	244
-	1	1	1	1	2079764-1	WASHER, WAVE SPRING, CREST-TO-CREST	243
-	1	1	1	1	2119083-1	RETAINER, INSULATION DIAL	242
-	1	1	1	1	7-18023-7	SCR, SKT HD CAP M3 X 4.0	241
-	-	1	-	1	2119580-1	MECHANICAL FEED ASSEMBLY	239
-	1	-	1	-	2844940-1	AIR FEED MODULE	238
-	2	2	2	2	1-2079383-0	SCR, BHSC, RoHS (M3 X 6)	230
-	1	1	1	1	1-1633764-4	HOLD DOWN, TERMINAL	179
-	1	1	1	1	993111-1	PIN, SLOTTED SPRING 3.0 X 20.0	177
-	1	1	1	1	8-22280-7	SPRING, COMPRESSION	176
-	1	1	1	1	1752353-2	GUIDE PIN, HOLDDOWN	175
-	1	1	1	1	1901680-2	GUIDE PIN, HOLDDOWN	174
-	REF	REF	REF	REF	994970-2	COUNTER, MAGNETIC	164
-	1	1	1	1	1-18028-2	WASHER, FLAT, REG M4	119
-	1	1	1	1	2119955-1	ASSY, LUBRICATOR, SIDE FEED	113
-	1	1	1	1	2844908-1	SCREW, LOCKING	99
-	1	1	1	1	2844907-1	POST, LOCKING	98
-	1	1	1	1	455888-6	SPACER, CRIMPER	82
-	1	1	1	1	1803607-3	DOCUMENTATION PACKAGE	71
-	1	1	1	1	2119740-1	TAG, IDENTIFICATION	67
-	2	2	2	2	2168078-1	SCREW, DRIVE, RH, RoHS, 2 x .188	66
-	1	1	1	1	2168083-2	SCR, SKT HD CAP, RoHS, M4 X 8.0	60
-	1	1	1	1	5-18022-5	SCR, HEX HD CAP, M4 X 6.0	59
-	1	1	1	1	1338685-1	PAWL, FEED	56
-	4	4	4	4	2168083-3	SCR, SKT HD CAP, RoHS, M4 X 12.0	54
-	1	1	1	1	1-5018030-0	NUT, HEX, REG, RoHS, M3.5	52
-	1	1	1	1	1901681-8	HOLDDOWN, TERMINAL	51
-	1	1	1	1	1-1752354-6	STANDOFF, HOLD-DOWN	50
-	1	2	1	2	18023-9	SCR, SKT HD CAP M4 X 6.0	49
-	-	1	-	1	2119652-1	FEED CAM, PRE FEED	48
-	-	1	-	1	2119653-1	FEED CAM, POST FEED	47
-	1	1	1	1	1803583-9	APPLICATOR BASIC ASSEMBLY, SF	46
-	1	1	1	1	1803515-3	RAM ASSEMBLY, SF ATLANTIC	44
-	1	1	1	1	1803602-1	SCR, BHSC, RoHS (M8 X 25)	41
-	1	1	1	1	1752356-3	SUPPORT, TERMINAL	34
-	2	2	2	2	2079383-5	SCR, BHSC, RoHS (M4 X 20)	33
-	2	2	2	2	2-2844962-8	SPACER, CYLINDRICAL, STRIP GUIDE	30
-	1	1	1	1	2844992-1	ASSEMBLY, STRIP GUIDE	29
-	1	1	1	1	1-455888-0	SPACER, CRIMPER	28
-	1	1	1	1	1320928-2	STRIP GUIDE	24
-	1	1	1	1	2168083-2	SCR, SKT HD CAP, RoHS, M4 X 8.0	21
-	1	1	1	1	1-18028-2	WASHER, FLAT, REG M4	20
-	1	1	1	1	2119533-3	STRIPPER, SIDE FEED	19
-	1	2	2	1	1633988-1	CRIMPER, INSULATION BOX PREMIUM	14
-	1	1	1	1	2119806-1	INSERT, SHEAR	13
-	1	1	1	1	3-22280-3	SPRING, COMPRESSION	12
-	1	1	1	1	1-356885-4	STOP, SHEAR	11
-	1	1	1	1	2119805-1	SHEAR HOLDER, FRONT	10
-	1	1	1	1	1803095-6	FLOATING SHEAR, FRONT	9
-	1	2	2	1	4-1633128-4	ANVIL, COMBINATION .055	8
-	1	1	1	1	2119757-8	DEPRESSOR, SHEAR	5
-	1	1	1	1	238011-9	BLOCK, CRIMPER SPACER	4
-	1	2	2	1	2119582-9	CRIMPER, INSULATION F PREMIUM	3
-	1	1	1	1	455888-5	SPACER, CRIMPER	2
-	1	2	2	1	7-1633305-2	CRIMPER, WIRE PREMIUM	1

DIMENSIONS:		TOLERANCES UNLESS OTHERWISE SPECIFIED:		OWN	DATE	NAME
mm	0 PLC ±	1 PLC ±	2 PLC ±	H. HUANG	19AUG2011	TE Connectivity
	3 PLC ±	4 PLC ±	ANGLES ±	CHK		Harrisburg, PA 17105-3608
	FINISH			APVD	19AUG2011	Ocean Side Feed
				PRODUCT SPEC		Applicator
				APPLICATION SPEC		
MATERIAL				SIZE	CAGE CODE	DRAWING NO
				A1	00779	2151072
				WEIGHT		
				Customer Accessible Production Drawing	SCALE	1:2
				SHEET	1	OF 4
				REV	F	

LOC	DIST	REVISIONS					
A	66	P	LTN	DESCRIPTION	DATE	OWN	APVD
		-		SEE SHEET 1			

# FEED TYPE MECHANICAL

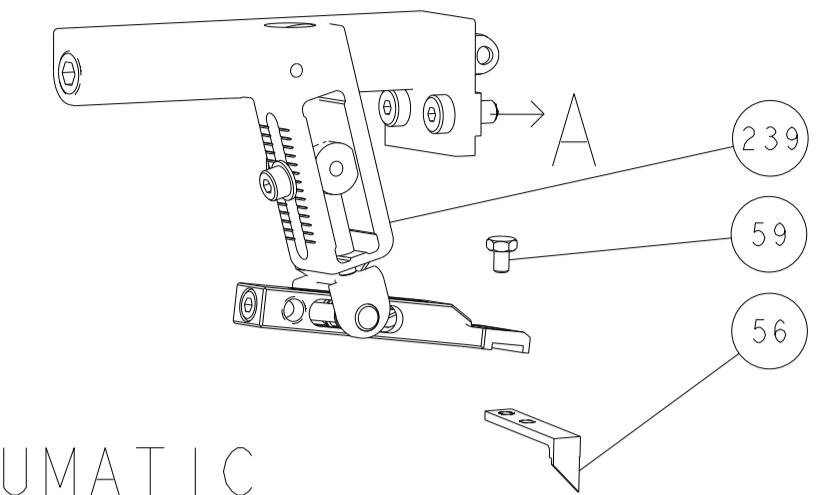

## PNEUMATIC

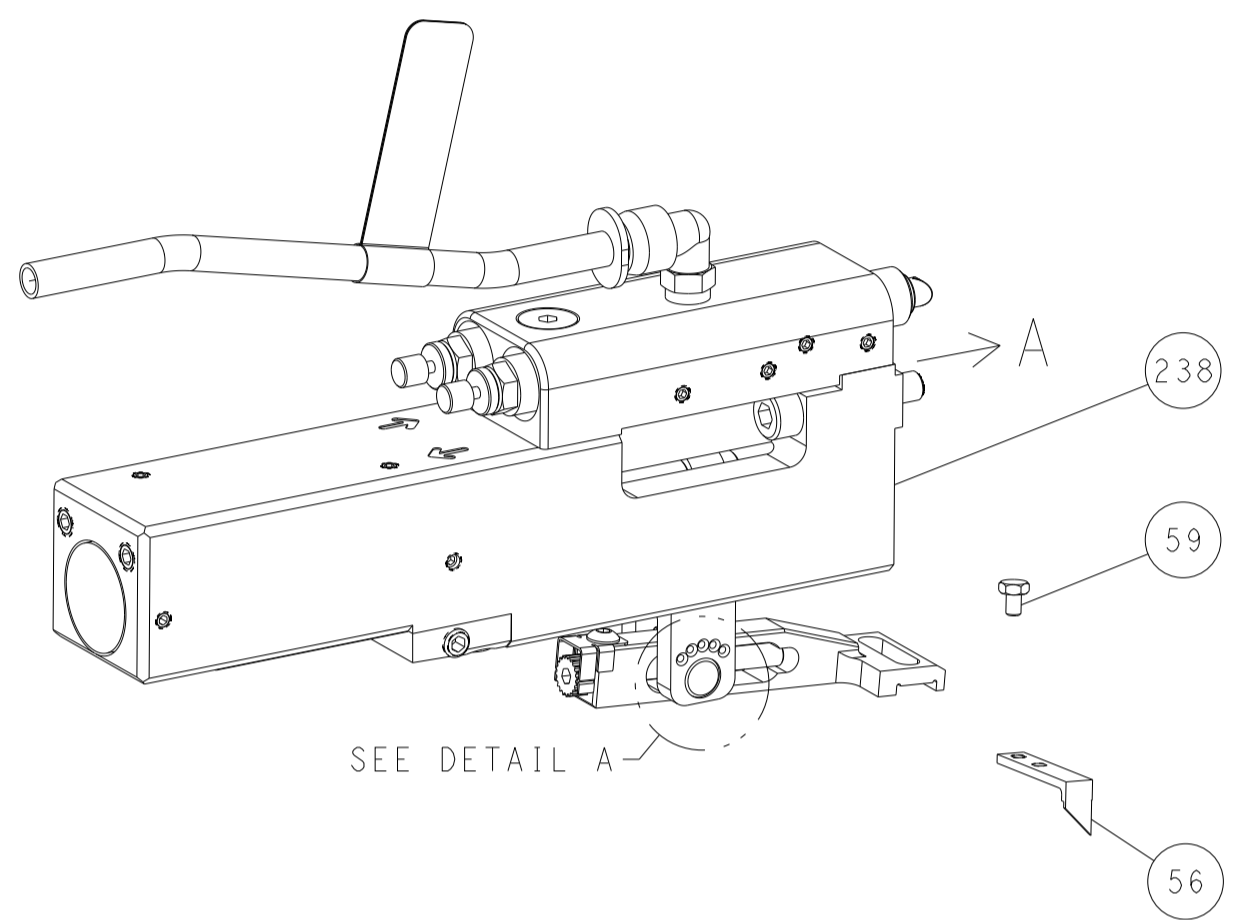

## FEED SPRING SETTING POSITION (SHOWN FROM REAR SIDE)

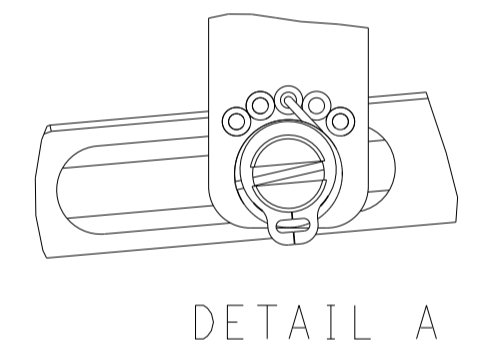

DETAIL A

# CAM POSITIONS

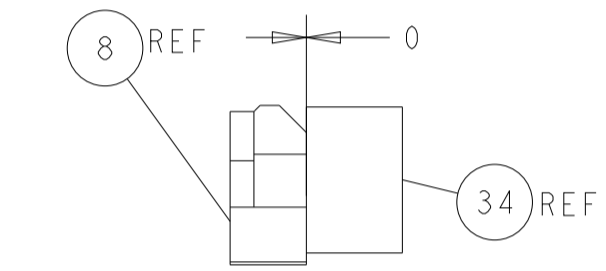
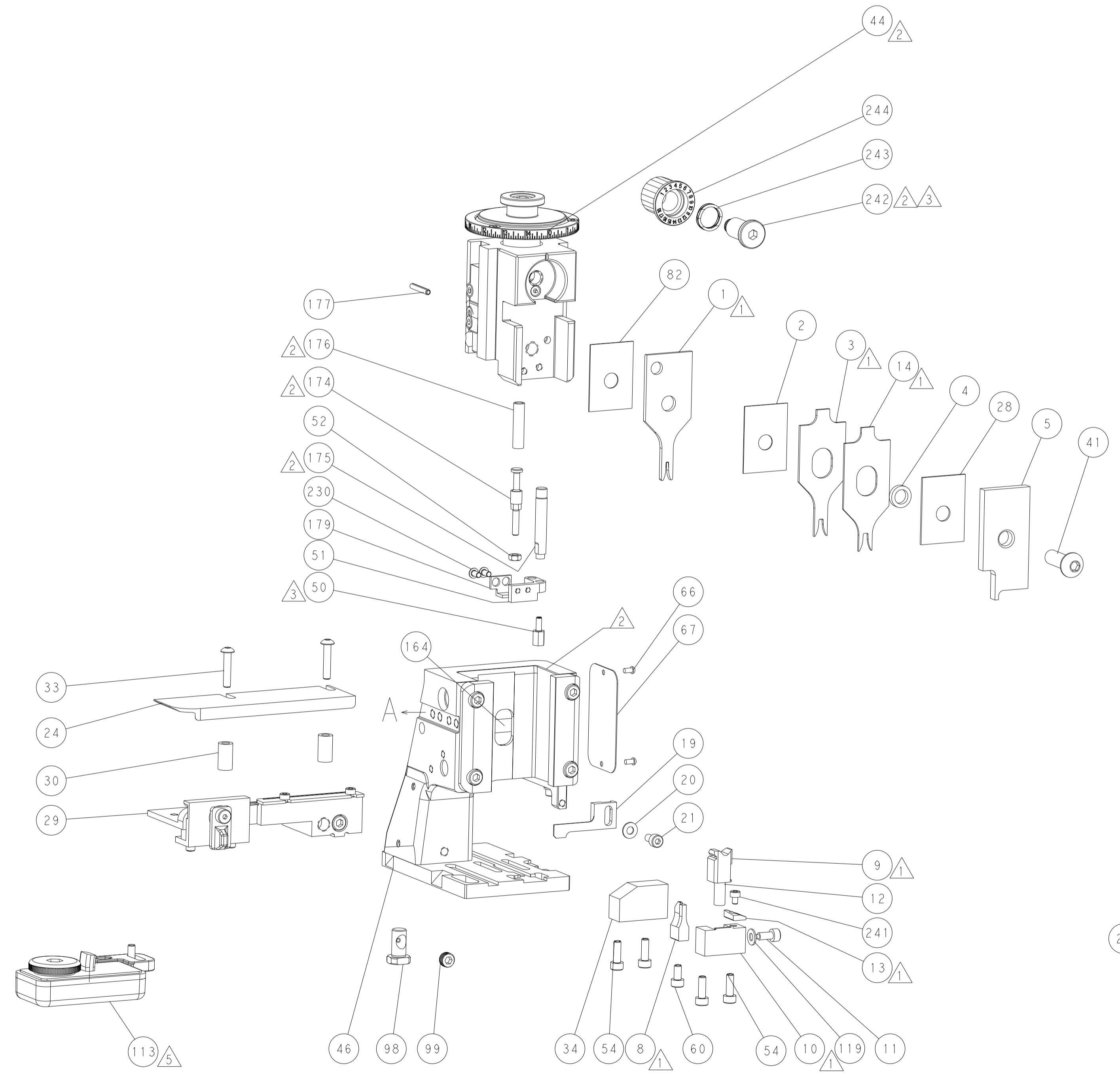
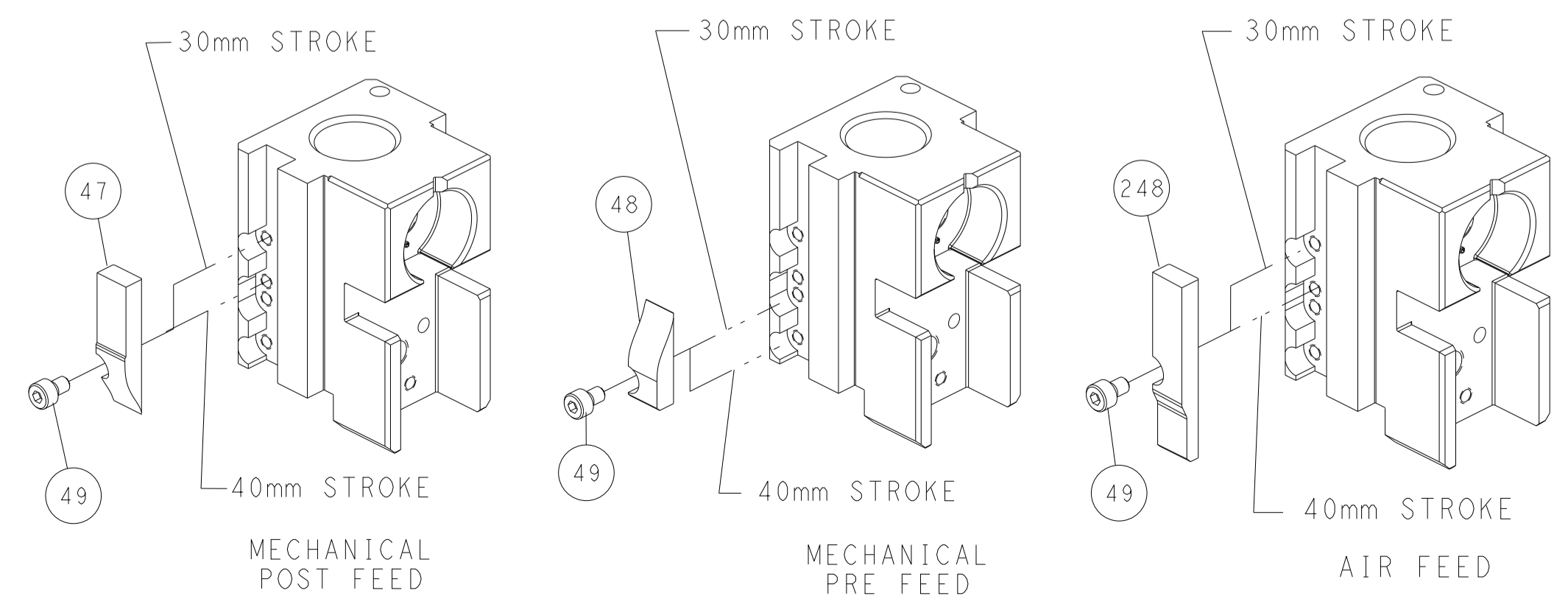

TERMINAL SUPPORT LOCATION

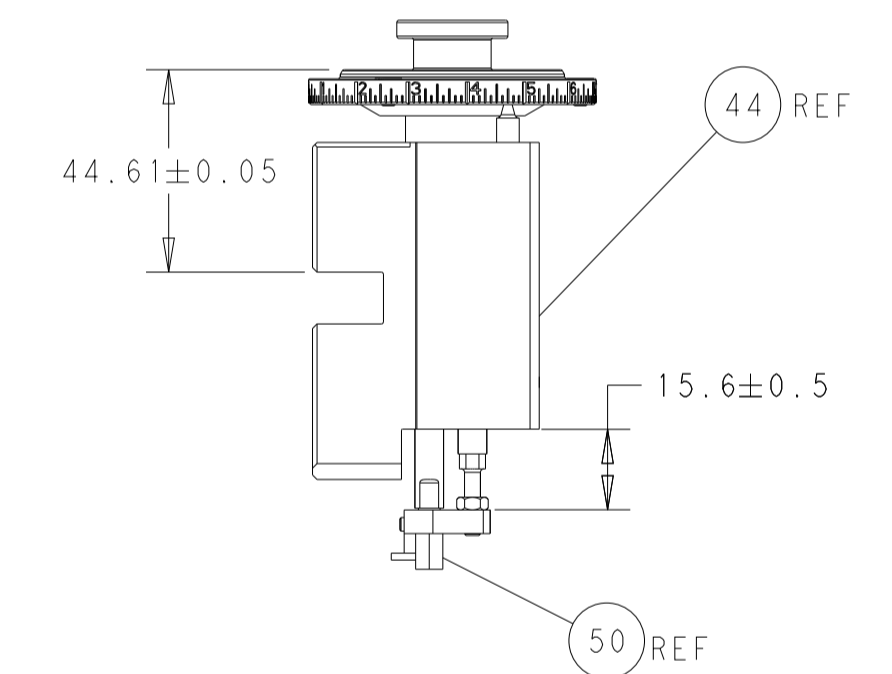

RAM AND HOLDDOWN SET-UP

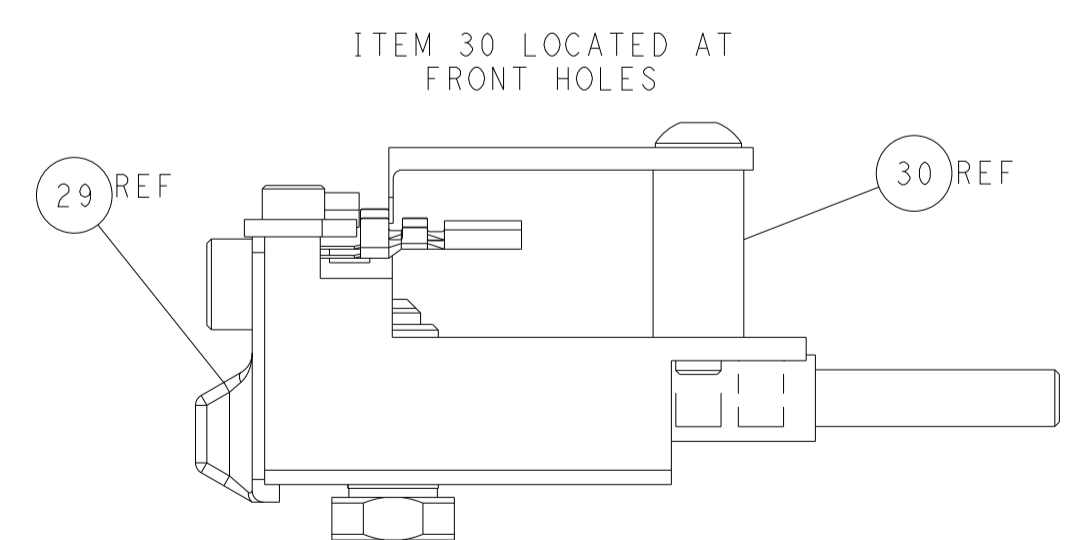

FEED TRACK POSITION GUIDE BY INSULATION BARREL

**ATLANTIC VERSION**  
 Shown on sheets 1 of 4 & 2 of 4  
 (Pacific version shown on sheets 3 of 4 & 4 of 4)

<small>THIS DRAWING IS UNPUBLISHED. RELEASED FOR PUBLICATION. ALL RIGHTS RESERVED. THIS DRAWING IS CONTROLLED DOCUMENT FOR TYCO ELECTRONICS CORPORATION. IT IS THE PROPERTY OF TYCO ELECTRONICS CORPORATION AND IS NOT TO BE REPRODUCED OR TRANSMITTED IN ANY FORM OR BY ANY MEANS, ELECTRONIC OR MECHANICAL, INCLUDING PHOTOCOPYING, RECORDING, OR BY ANY INFORMATION STORAGE AND RETRIEVAL SYSTEM, WITHOUT THE WRITTEN PERMISSION OF TYCO ELECTRONICS CORPORATION.</small>		DWN: R. HUANG CHK: S. XI APVD: S. XI DATE: 19AUG2011 PRODUCT SPEC: - APPLICATION SPEC: - WEIGHT: - SCALE: 1:2	NAME: Ocean Side Feed Applicator SIZE: A1 CAGE CODE: 00779 DRAWING NO: C=2151072 SHEET: 2 OF 4 REV: F	TE Connectivity Harrisburg, PA 17105-3608
--	--	--	--	--

PART NUMBER	REVISION	DESCRIPTION	FEED TYPE
2-2151072-1	F	FINE CRIMP HEIGHT ADJUST	MECHANICAL
2-2151072-2	F	FINE CRIMP HEIGHT ADJUST	PNEUMATIC
7-2151072-7	E	CRIMP TOOLING KIT	-

PACIFIC VERSION TERMINATOR  
 INTERFACE ADAPTER

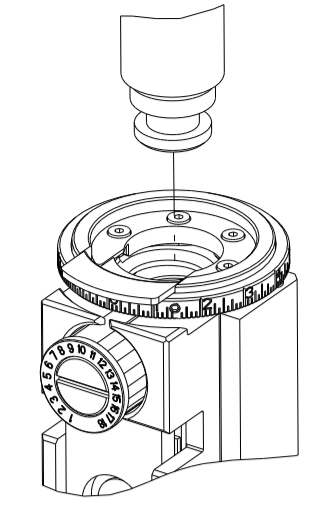

APPLICATOR DATA		
CRIMP	SIZE	TYPE
WIRE	1.40 mm [.055]	F
INSUL	2.75 mm [.108]	F

APPLICATOR INSTRUCTIONS  
 408-35042

TERMINAL DATA: TE TERMINAL		TE CRIMP SPECIFICATION	
TERMINAL NAME: AMP POWER DBL LOCK CONN, REC. CONTACT			
WIRE STRIP LENGTH	INSULATION DIAMETER RANGE		
3.00-4.00 mm [.118-.157 IN]	Ø1.30-2.00 mm [.051-.079 IN]		
TERMINAL APPLICATION SPECIFICATION	(A)114-5175	-	-
TERMINALS APPLIED			
TE TERMINAL	TE TERMINAL	TE TERMINAL	TE TERMINAL
(A) 177914-1	(A) 177914-2	(A) 177916-1	(A) 1-177916-1
(A) 5-177916-1	(A) 2369502		

TERMINAL DATA: TE TERMINAL		TE CRIMP SPECIFICATION	
TERMINAL NAME: AMP POWER DBL LOCK CONN, REC. CONTACT			
WIRE STRIP LENGTH	INSULATION DIAMETER RANGE		
3.00-4.00 mm [.118-.157 IN]	Ø1.30-2.00 mm [.051-.079 IN]		
TERMINAL APPLICATION SPECIFICATION	114-61016	-	-
TERMINALS APPLIED			
TE TERMINAL	TE TERMINAL	TE TERMINAL	TE TERMINAL
1743728-1			

WIRE SIZE	CRIMP HEIGHT mm [INCH]	CRIMP HEIGHT REFERENCE SETTING
0.51mm2 OR 20 AWG	0.98 +/- 0.05 [.039 +/- .002]	7.5
0.34mm2 OR 22 AWG	0.89 +/- 0.05 [.035 +/- .002]	8.4
0.22mm2 OR 24 AWG	0.85 +/- 0.05 [.033 +/- .002]	8.8
0.14mm2 OR 26 AWG	0.80 +/- 0.05 [.031 +/- .002]	9.4

- 1 RECOMMENDED SPARE PARTS
- 2 REFER TO SUPPLIED INSTRUCTION SHEET FOR CLEANING, LUBRICATION AND STORAGE OF APPLICATOR.
- 3 APPLY PART NUMBER 1-23419-5 LOCTITE TO THREADS OF ITEM 50. APPLY PART NUMBER 2-23419-6 LOCTITE TO THREADS OF ITEM 242.
- 4 CRIMP HEIGHT REFERENCE SETTING WAS THE SETTING USED WHEN THE APPLICATOR WAS QUALIFIED AT THE FACTORY. ADJUSTMENT MAY BE NECESSARY WHEN RUNNING APPLICATOR IN THE FIELD.
- 5 TERMINAL LUBRICANT IS RECOMMENDED.
- 6. UNLESS SPECIFIED OTHERWISE TORQUE VALUES SHALL BE USED PER DOCUMENT, 101-35000.
- 7 INSULATION DIAMETER RANGE FOR 22 AWG WIRE IS Ø2.2MM [.0871N].

**\*WARNING**  
 ON INSTALLATION, SET WIRE DISC TO CRIMP HEIGHT REFERENCE SETTING FOR LARGEST WIRE SIZE. CRIMP HEIGHT REFERENCE SETTINGS GREATER THAN THE VALUE SHOWN MAY CAUSE DAMAGE TO THE CRIMP TOOLING, REFER TO THE INSTRUCTION SHEET FOR PROPER SETUP AND ADJUSTMENTS.

PACIFIC VERSION  
 Shown on sheets 3 of 4 & 4 of 4  
 (Atlantic version shown on sheets 1 of 4 & 2 of 4)

LOC	DIST	REVISIONS					
A	66	P	LTN	DESCRIPTION	DATE	OWN	APVD
		-		SEE SHEET 1			

-	1	1	2119082-9	CAM, SNAIL, INSULATION ADJUSTMENT	244
-	1	1	2079764-1	WASHER, WAVE SPRING, CREST-TO-CREST	243
-	1	1	2119083-1	RETAINER, INSULATION DIAL	242
-	1	1	7-18023-7	SCR, SKT HD CAP M3 X 4.0	241
-	-	1	2119580-1	MECHANICAL FEED ASSEMBLY	239
-	1	-	2844940-1	AIR FEED MODULE	238
-	2	2	1-2079383-0	SCR, BHSC, RoHS (M3 X 6)	230
-	1	1	1-1633764-4	HOLD DOWN, TERMINAL	179
-	1	1	993111-1	PIN, SLOTTED SPRING 3.0 X 20.0	177
-	1	1	8-22280-7	SPRING, COMPRESSION	176
-	1	1	1752353-2	GUIDE PIN, HOLDDOWN	175
-	1	1	1901680-2	GUIDE PIN, HOLDDOWN	174
-	REF	REF	994970-2	COUNTER, MAGNETIC	164
-	1	-	2119641-2	FEED CAM, AIR FEED	151
-	1	1	2168083-8	SCR, SKT HD CAP, RoHS, M4 X 16	144
-	4	4	2168083-9	SCR, SKT HD CAP, RoHS, M4 X 20	143
-	-	1	2119653-2	FEED CAM, POST FEED	142
-	1	1	1-1803583-0	APPLICATOR BASIC ASSEMBLY, SF	141
-	1	1	1803516-1	RAM ASSEMBLY, SF PACIFIC	140
-	1	1	1-18028-2	WASHER, FLAT, REG M4	119
-	1	1	2119955-1	ASSY, LUBRICATOR, SIDE FEED	113
-	1	1	2844908-1	SCREW, LOCKING	99
-	1	1	2844907-1	POST, LOCKING	98
-	1	1	455888-6	SPACER, CRIMPER	82
-	1	1	1803607-3	DOCUMENTATION PACKAGE	71
-	1	1	2119740-1	TAG, IDENTIFICATION	67
-	2	2	2168078-1	SCREW, DRIVE, RH, RoHS, 2 x .188	66
-	1	1	5-18022-5	SCR, HEX HD CAP, M4 X 6.0	59
-	1	1	1338685-1	PAWL, FEED	56
-	1	1	1-5018030-0	NUT, HEX, REG, RoHS, M3.5	52
-	1	1	1901681-8	HOLDDOWN, TERMINAL	51
-	1	1	1-1752354-6	STANDOFF, HOLD-DOWN	50
-	1	2	18023-9	SCR, SKT HD CAP M4 X 6.0	49
-	-	1	2119652-1	FEED CAM, PRE FEED	48
-	1	1	1803602-1	SCR, BHSC, RoHS (M8 X 25)	41
-	1	1	1752356-3	SUPPORT, TERMINAL	34
-	2	2	2079383-5	SCR, BHSC, RoHS (M4 X 20)	33
-	2	2	2-2844962-8	SPACER, CYLINDRICAL, STRIP GUIDE	30
-	1	1	2844992-1	ASSEMBLY, STRIP GUIDE	29
-	1	1	1-455888-0	SPACER, CRIMPER	28
-	1	1	1320928-2	STRIP GUIDE	24
-	1	1	2168083-2	SCR, SKT HD CAP, RoHS, M4 X 8.0	21
-	1	1	1-18028-2	WASHER, FLAT, REG M4	20
-	1	1	2119533-3	STRIPPER, SIDE FEED	19
1	1	1	1633988-1	CRIMPER, INSULATION BOX PREMIUM	14
-	1	1	2119806-1	INSERT, SHEAR	13
-	1	1	3-22280-3	SPRING, COMPRESSION	12
-	1	1	1-356885-4	STOP, SHEAR	11
-	1	1	2119805-1	SHEAR HOLDER, FRONT	10
-	1	1	1803095-6	FLOATING SHEAR, FRONT	9
1	1	1	4-1633128-4	ANVIL, COMBINATION .055	8
-	1	1	2119757-8	DEPRESSOR, SHEAR	5
-	1	1	238011-9	BLOCK, CRIMPER SPACER	4
1	1	1	2119582-9	CRIMPER, INSULATION F PREMIUM	3
-	1	1	455888-5	SPACER, CRIMPER	2
1	1	1	7-1633305-2	CRIMPER, WIRE PREMIUM	1

DIMENSIONS:		TOLERANCES UNLESS OTHERWISE SPECIFIED:		DRAWING NO		RESTRICTED TO	
mm	0 PLC ±	1 PLC ±	2 PLC ±	3 PLC ±	4 PLC ±	5 PLC ±	6 PLC ±
	ANGLES	FINISH					
MATERIAL				WEIGHT	SCALE	SHEET	REV
					1:2	3 OF 4	F



Ocean Side Feed  
 Applicator

LOC	DIST	REVISIONS					
A	66	P	LTN	DESCRIPTION	DATE	DWN	APVD
		-		SEE SHEET 1			

# FEED TYPE MECHANICAL

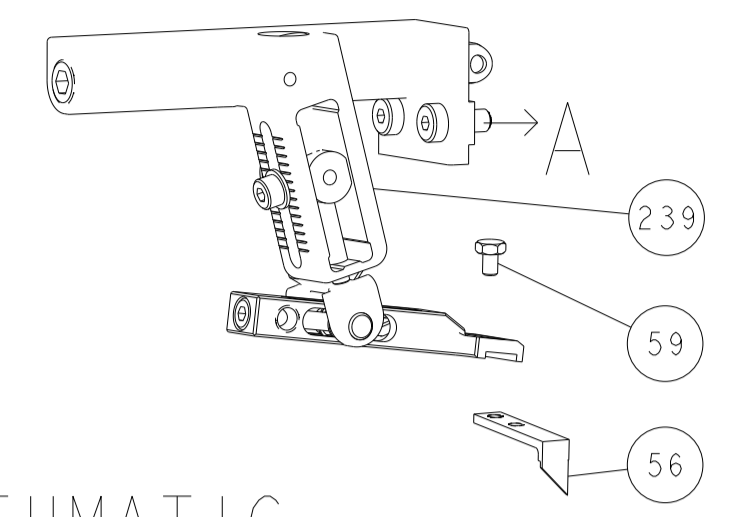

## PNEUMATIC

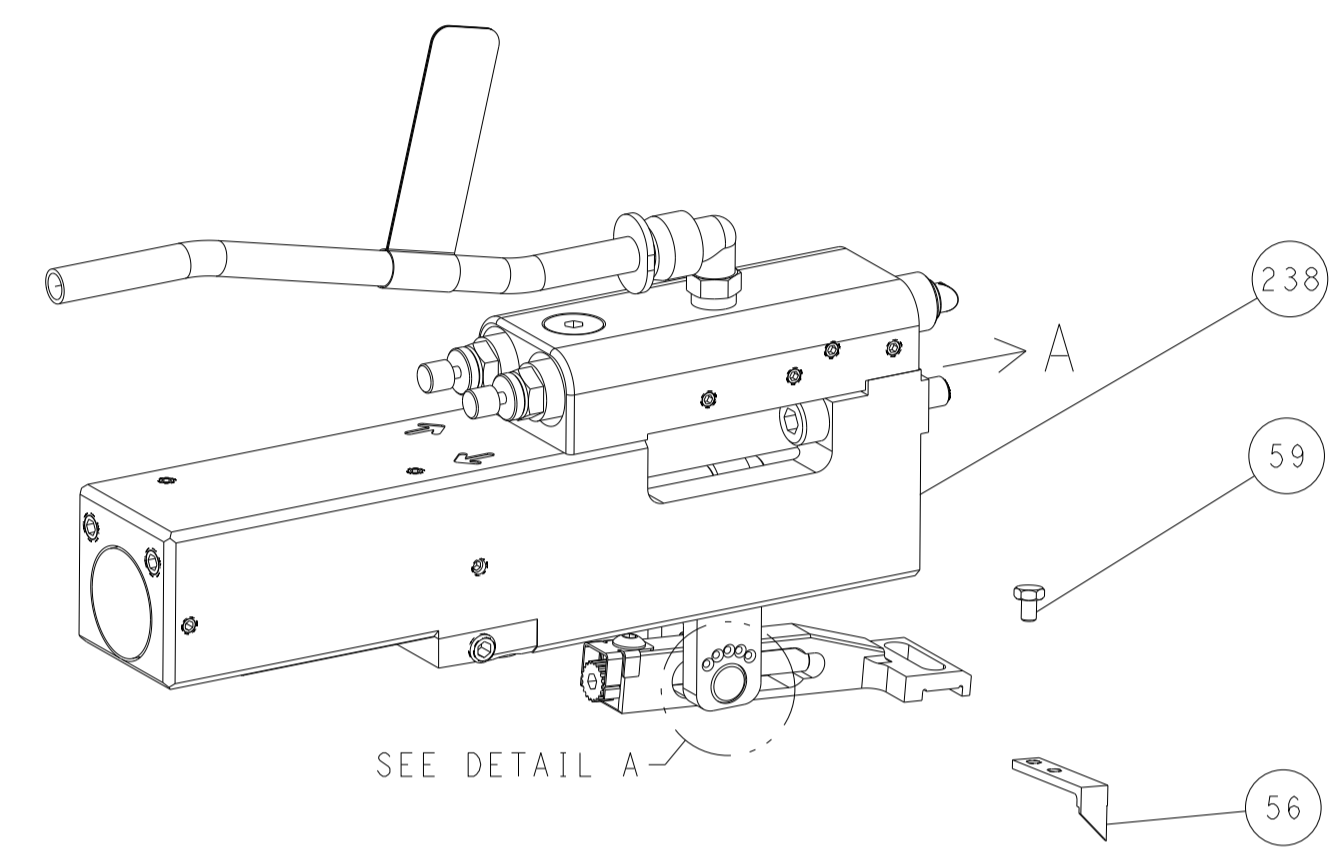

## FEED SPRING SETTING POSITION (SHOWN FROM REAR SIDE)

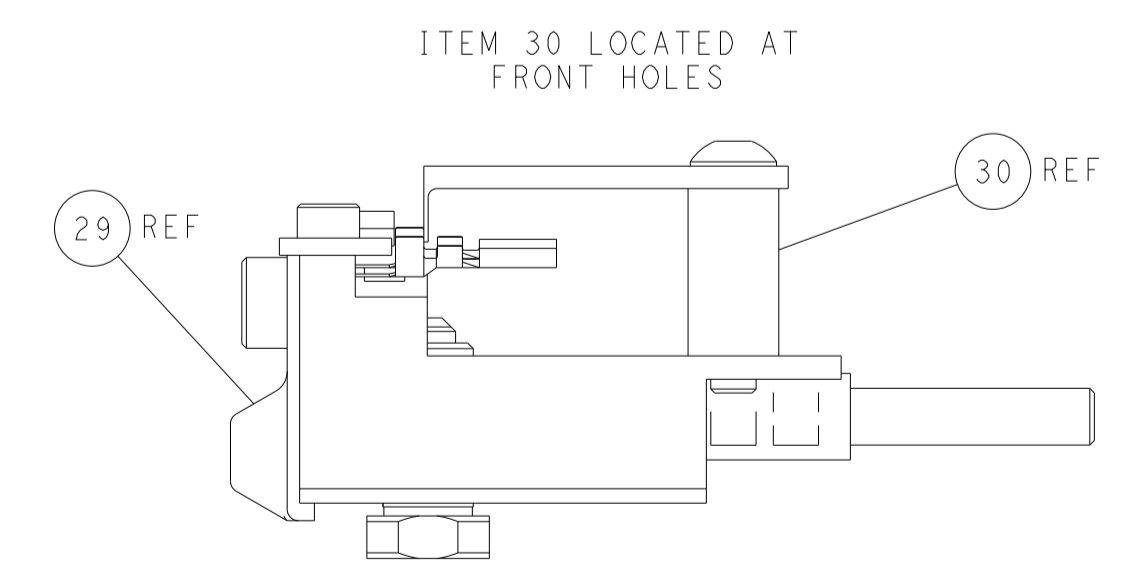
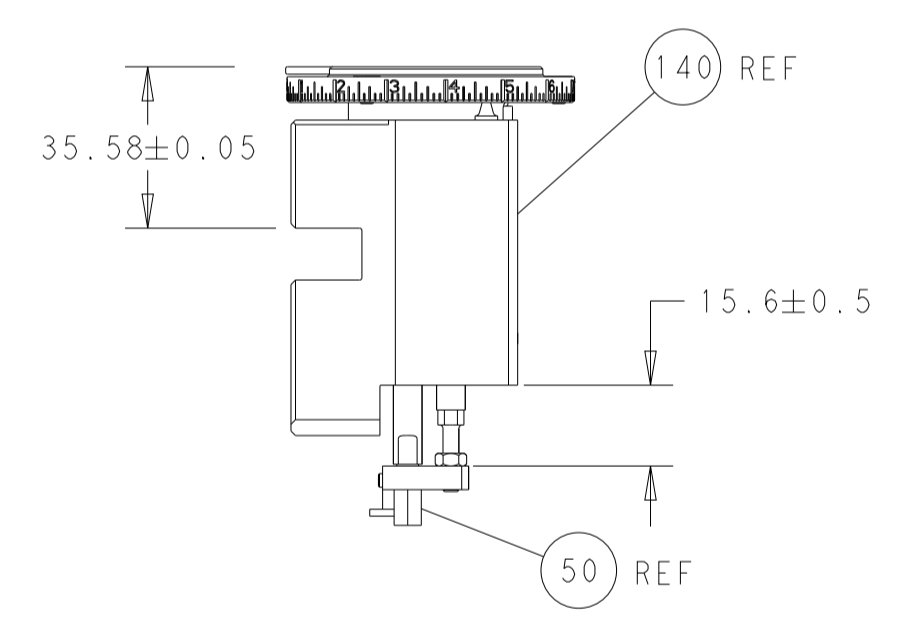
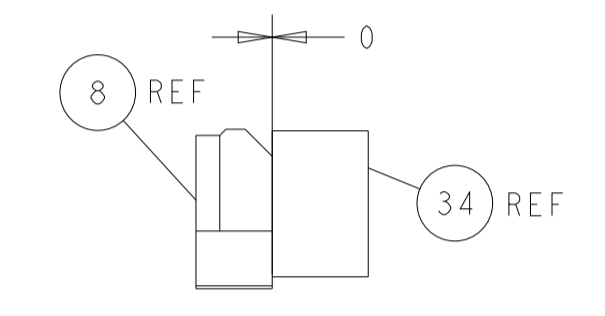
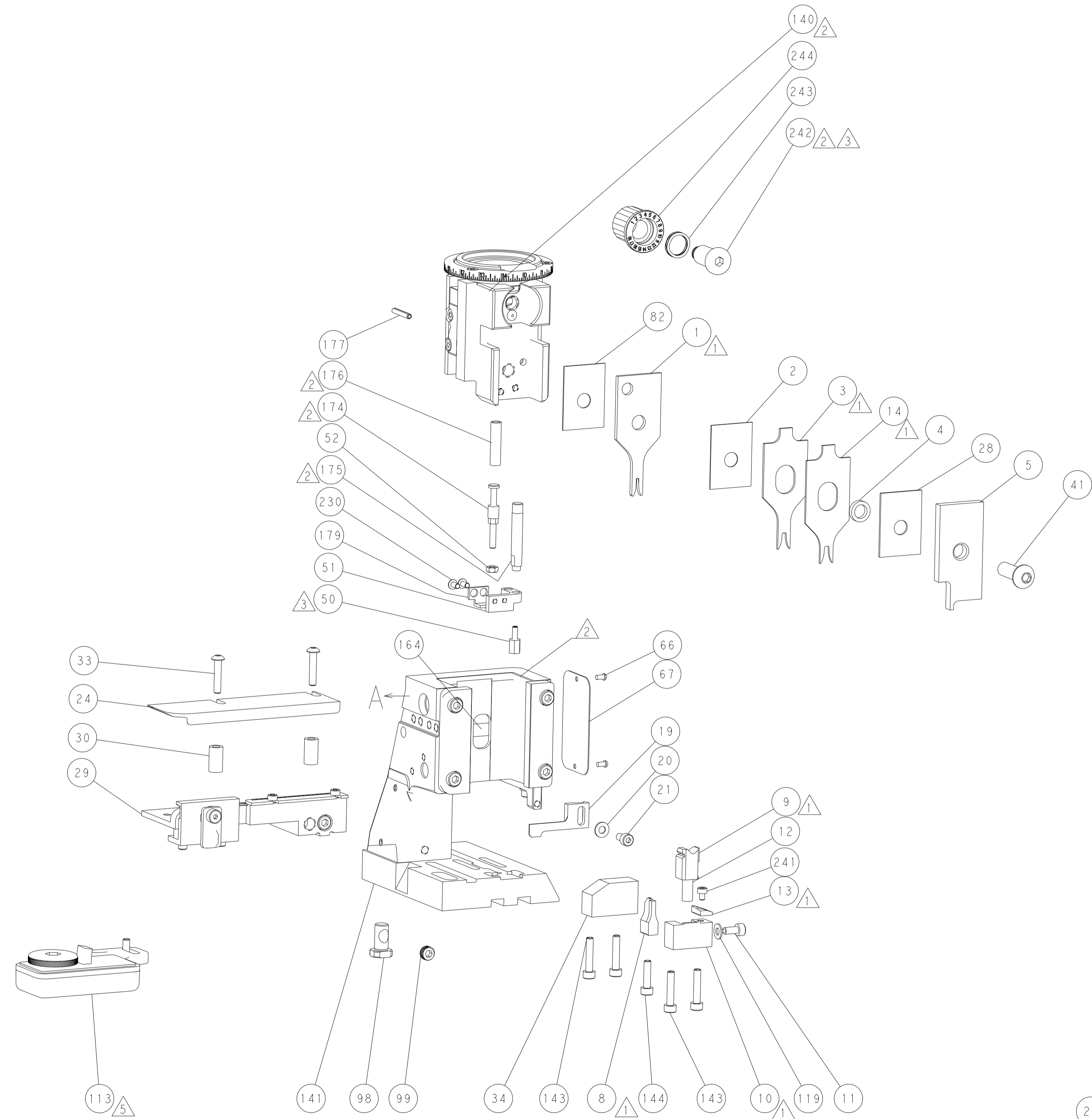
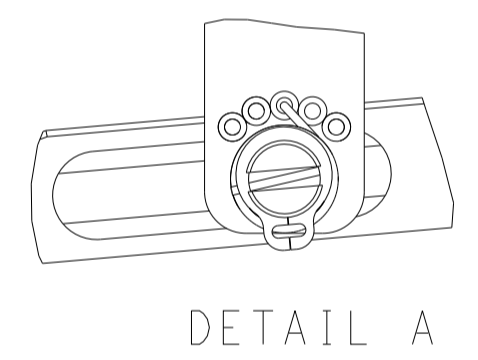

# CAM POSITIONS

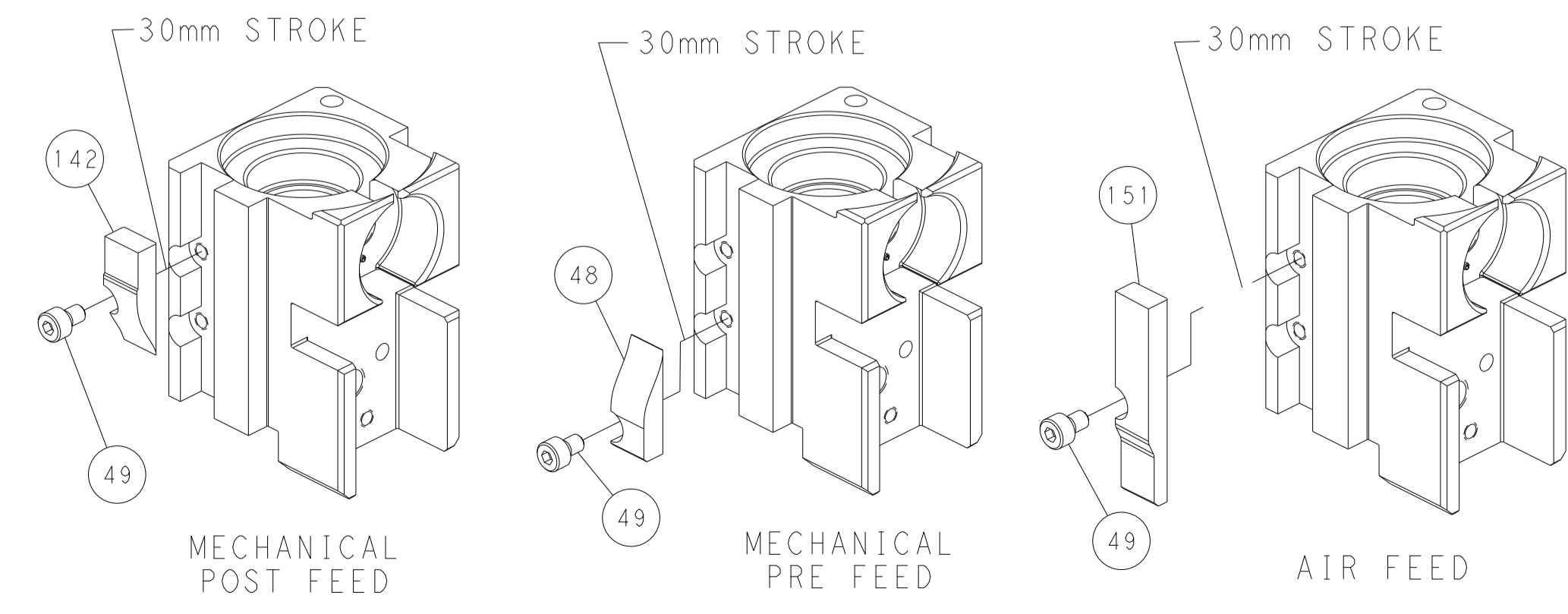

**PACIFIC VERSION**  
 Shown on sheets 3 of 4 & 4 of 4  
 (Atlantic version shown on sheets 1 of 4 & 2 of 4)

DIMENSIONS:		TOLERANCES UNLESS OTHERWISE SPECIFIED:		DWN R. HUANG 19AUG2011		TE Connectivity Harrisburg, PA 17105-3608	
mm	0 PLC ±	1 PLC ±	2 PLC ±	3 PLC ±	4 PLC ±	APVD S. XI 19AUG2011	NAME Ocean Side Feed Applicator
MATERIAL:		FINISH:		WEIGHT:		SIZE A1	
						CAGE CODE 00779	
						DRAWING NO 2151072	
						RESTRICTED TO	
						SCALE 1:2	
						SHEET 4 OF 4	
						REV F	