

3-phase inverter based on STSPIN32F0601 with 3-shunt topology



Features

- Input voltage from 50 V to 280 V DC/AC
- STGD6M65DF2 IGBTs power stage featuring:
 - $V_{(BR)CES} = 650 \text{ V}$
 - $V_{CE(sat)} = 1.55 \text{ V @ } I_C = 6 \text{ A}$
- Overcurrent threshold set to 4.5 A_{peak}
- Dual footprint for IGBT/MOSFET package:
 - DPAK
 - PowerFlat 8x8 HV
- 3-shunt current sensing, suitable for: sensed or sensorless vector control - FOC algorithm with 3-shunt sensing
- Smart shutdown overcurrent protection
- Digital Hall sensors and encoder input
- Bus voltage sensing
- 15 V VCC and 3.3 V VDD supplies
- Embedded ST-LINK/V2-1
- Easy user interface with buttons and trimmer
- RoHS compliant

Applications

- Home and Industrial refrigerators compressors
- Industrial drives, pumps, fans
- Air conditioning compressors & fans
- Corded power tools, garden tools
- Home appliances
- Industrial automation

Product status link

[EVSPIN32F0601S3](#)

Description

The **EVSPIN32F0601S3** board is a 3-phase complete inverter based on the STSPIN32F0601 controller, which embeds a 3-phase 600 V gate driver and a Cortex[®]-M0 STM32 MCU. The power stage features STGD6M65DF2 IGBTs, but can be populated with any IGBT or Power MOSFET in DPAK or powerFLAT 8x8 HV package.

The board has a three-shunt sensing topology, and the field-oriented control (FOC), either sensed or sensorless, can be implemented. This makes it especially suited to drive permanent magnet synchronous motors (PMSMs).

The evaluation board is compatible with a wide range input voltage from 50 V to 280 V DC/AC, and includes a power supply stage with the VIPER06XS in flyback configuration to generate +15 V and +3.3 V supply voltage required by the application.

Debug and configuration of FW can be performed with standard STM32 tools through the detachable STLINK-debugger. SWD and UART TX-RX connectors are also available.

1 Safety and operating instructions



1.1 General terms

Warning:

During assembly, testing, and operation, the evaluation board poses several inherent hazards, including bare wires, moving or rotating parts and hot surfaces.

Danger:

There is danger of serious personal injury, property damage or death due to electrical shock and burn hazards if the kit or components are improperly used or installed incorrectly.

The kit is not electrically isolated from the high-voltage supply AC/DC input. The evaluation board is directly linked to the mains voltage. No insulation is ensured between the accessible parts and the high voltage. All measuring equipment must be isolated from the mains before powering the board. When using an oscilloscope with the demo, it must be isolated from the AC line. This prevents shock from occurring as a result of touching any single point in the circuit, but does NOT prevent shock when touching two or more points in the circuit.

All operations involving transportation, installation and use, and maintenance must be performed by skilled technical personnel able to understand and implement national accident prevention regulations. For the purposes of these basic safety instructions, "skilled technical personnel" are suitably qualified people who are familiar with the installation, use and maintenance of power electronic systems.

1.2 Intended use of evaluation board

The evaluation board is designed for demonstration purposes only, and must not be used for electrical installations or machinery. Technical data and information concerning the power supply conditions are detailed in the documentation and should be strictly observed.

1.3 Installing the evaluation board

- The installation and cooling of the evaluation board must be in accordance with the specifications and target application.
- The motor drive converters must be protected against excessive strain. In particular, components should not be bent or isolating distances altered during transportation or handling.
- No contact must be made with other electronic components and contacts.
- The board contains electrostatically-sensitive components that are prone to damage if used incorrectly. Do not mechanically damage or destroy the electrical components (potential health risks).

1.4 Operating the evaluation board

To operate properly the board, follow these safety rules.

1. Work Area Safety:

- The work area must be clean and tidy.
- Do not work alone when boards are energized.
- Protect against inadvertent access to the area where the board is energized using suitable barriers and signs.
- A system architecture that supplies power to the evaluation board must be equipped with additional control and protective devices in accordance with the applicable safety requirements (i.e., compliance with technical equipment and accident prevention rules).
- Use non-conductive and stable work surface.
- Use adequately insulated clamps and wires to attach measurement probes and instruments.

2. Electrical Safety:

- Remove power supply from the board and electrical loads before performing any electrical measurement.
- Proceed with the arrangement of measurement setup, wiring or configuration paying attention to high voltage sections.
- Once the setup is complete, energize the board.

Danger:

Do not touch the evaluation board when it is energized or immediately after it has been disconnected from the voltage supply as several parts and power terminals containing potentially energized capacitors need time to discharge.

Do not touch the boards after disconnection from the voltage supply as several parts like heat sinks and transformers may still be very hot.

The kit is not electrically isolated from the AC/DC input. The USB interface of the board does not insulate host computer from high voltage. When the board is supplied at a voltage outside the ELV range, a proper insulation method such as a USB isolator must be used to operate the board.

3. Personal Safety

- Always wear suitable personal protective equipment such as, for example, insulating gloves and safety glasses.
- Take adequate precautions and install the board in such a way to prevent accidental touch. Use protective shields such as, for example, insulating box with interlocks if necessary.

2 Schematic diagram

Figure 1. EVSPIN32F0601S3 schematic – Driver output stages

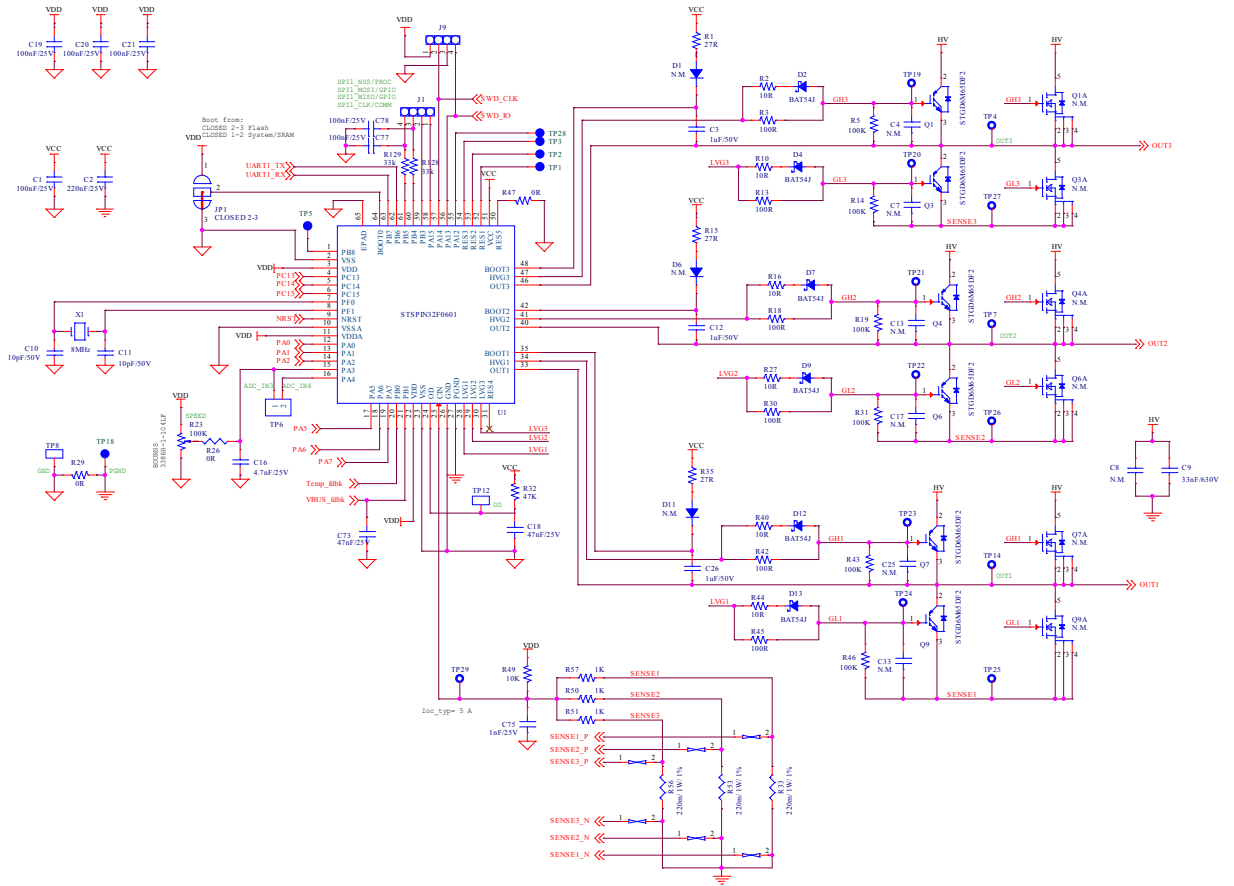

Figure 2. EVSPIN32F0601S3 schematic – Feedback network

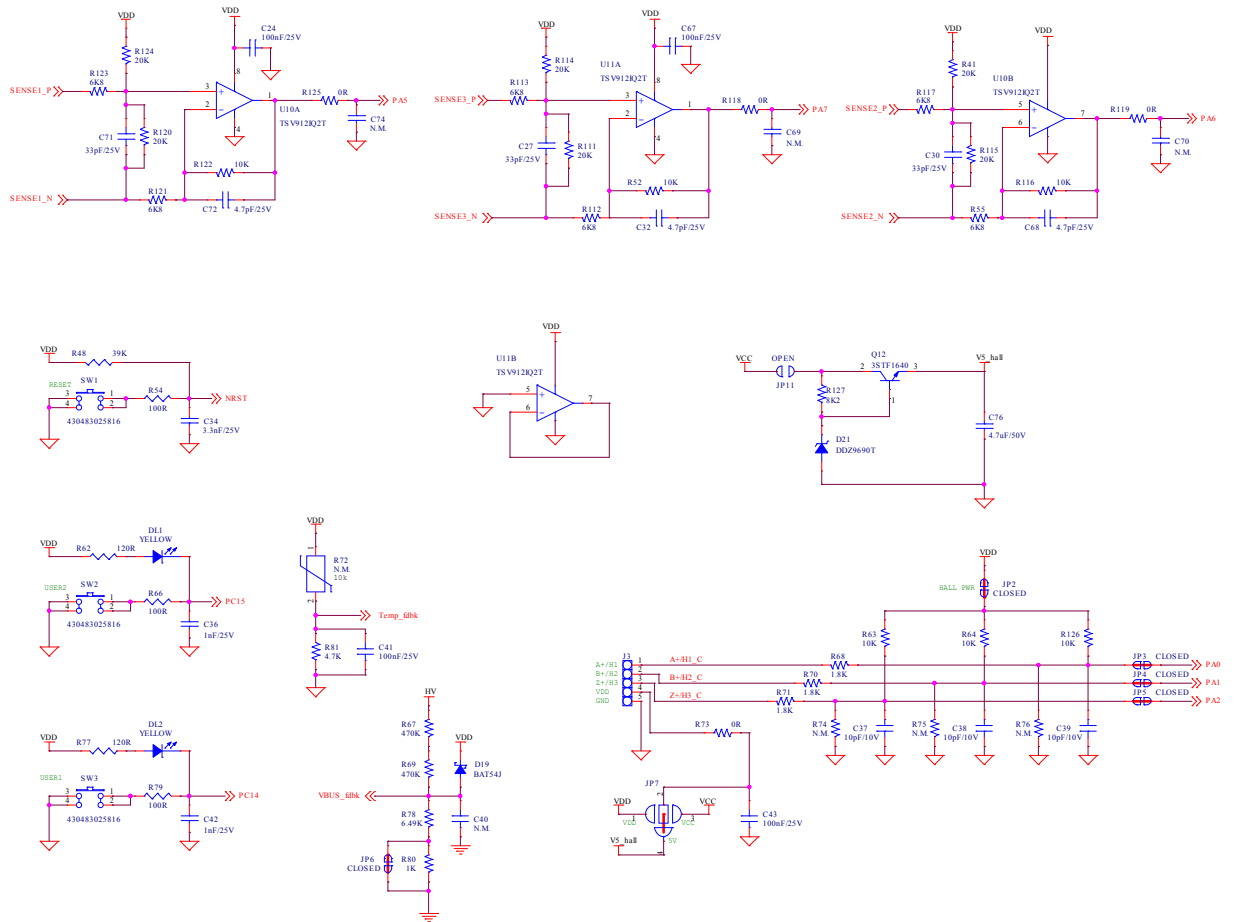
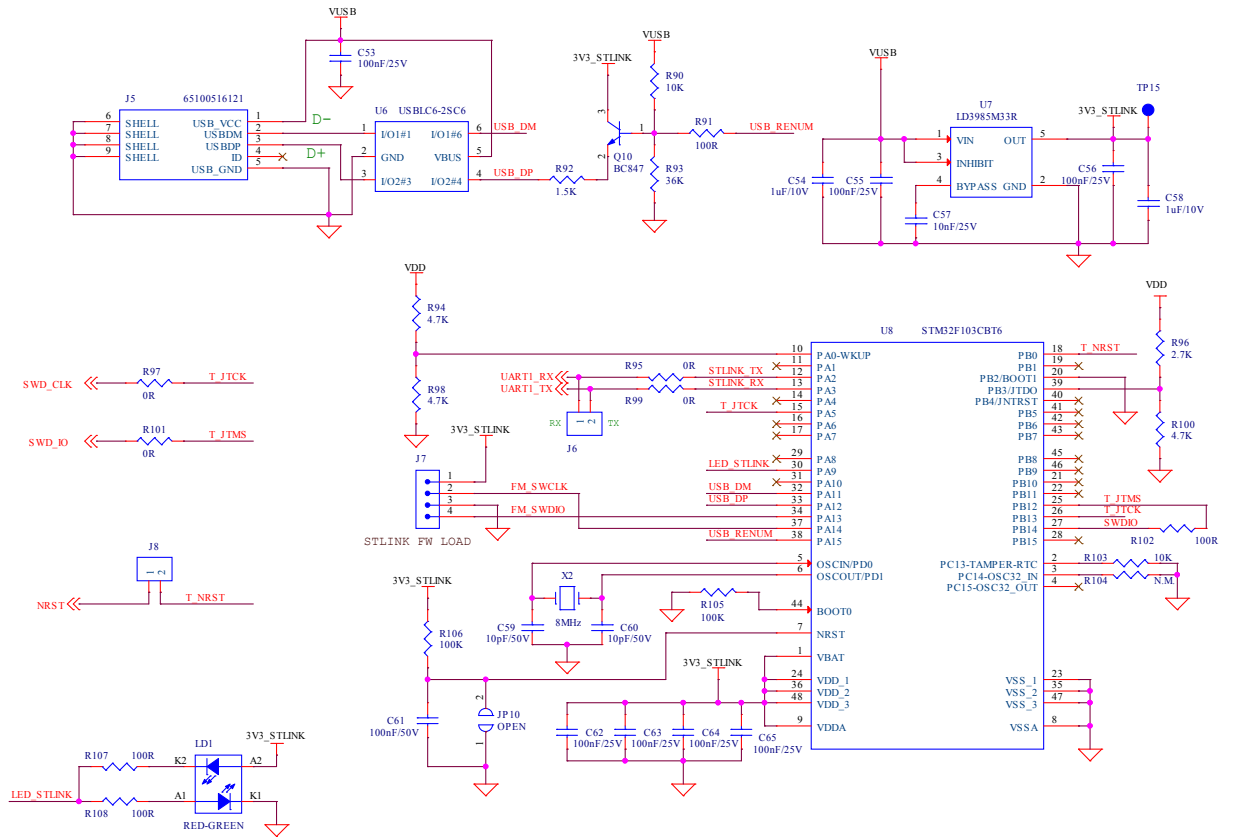

Figure 4. EVSPIN32F0601S3 schematic – STLINK debugger



3 Bill of Material

Table 1. Bill of Materials – Components common to all device variants

| Reference | Part Value | Description | Package | Manufacturer | Part Number |
|---|-------------|--|-----------------------|------------------|--------------------|
| C1 , C19, C20, C21, C24,C41, C43,C47,C53, C55, C56, C62, C63, C64, C65, C67, C77, C78 | 100nF/25V | SMT ceramic capacitor | Size 0603 | Würth Elektronik | 885012206071 |
| C2 | 220nF/25V | SMT ceramic capacitor | Size 0603 | Würth Elektronik | 885012106019 |
| C3, C12, C26 | 1uF/50V | SMT ceramic capacitor | Size 0805 | Würth Elektronik | 885012207103 |
| C4, C7, C13, C17, C25, C33, C40, C69, C70, C74 | N.M. | SMT ceramic capacitor | Size 0603 | | |
| C8 | N.M. | Film, metallized polypropylene | 5x13mm, Pitch 10mm | Würth Elektronik | 890283423001 |
| or C9 | 33nF/630V | SMT ceramic capacitor | Size 1210 | Würth Elektronik | 885342209004 |
| C10, C11, C59, C60 | 10pF/50V | SMT ceramic capacitor | Size 0603 | Würth Elektronik | 885012006051 |
| C16 | 4.7nF/25V | SMT ceramic capacitor | Size 0603 | Würth Elektronik | 885012206063 |
| C18,C73 | 47nF/25V | SMT ceramic capacitor | Size 0603 | Würth Elektronik | 885012206069 |
| C27, C30, C71 | 33pF/25V | SMT ceramic capacitor | Size 0603 | Würth Elektronik | 885012006035 |
| C32, C68, C72 | 4.7pF/25V | SMT ceramic capacitor | Size 0603 | Würth Elektronik | 885012006030 |
| C34 | 3.3nF/25V | SMT ceramic capacitor | Size 0603 | Würth Elektronik | 885012206062 |
| C36, C42, C75 | 1nF/25V | SMT ceramic capacitor | Size 0603 | Würth Elektronik | 885012206059 |
| C37, C38, C39 | 10pF/10V | SMT ceramic capacitor | Size 0603 | Würth Elektronik | 885012006002 |
| C44 | 150uF/420V | THT electrolytic capacitor, radial p10 d22h27 105C | Radial p10 d22h27.5mm | United Chemi-Con | EKMZ421VSN151MP25S |
| C44A | N.M. | THT electrolytic capacitor, radial p7.5 d18h25 | Radial p7.5 d18h25mm | Rubycon | 450BXW68MEFC18X25 |
| C45 | 22uF/25V | SMT aluminum elect. capacitor | 5x5.4mm | Würth Elektronik | 865090442004 |
| C46 | 470uF/10V | SMT aluminum elect. capacitor | 6.3x7.7mm | Panasonic | EEEFTA471XAP |
| C48 | 10uF/10V | SMT ceramic capacitor | Size 1206 | Würth Elektronik | 885012208018 |
| C49 | 47uF/25V | SMT aluminum elect. capacitor | 6.3x5.8mm | Würth Elektronik | 865060443004 |
| C50 | 10uF/35V | SMT aluminum elect. capacitor | 5x5.4mm | Würth Elektronik | 865230542002 |
| C51 | 820pF/25V | SMT ceramic capacitor | Size 0603 | | |
| C52 | 680nF/10V | SMT ceramic capacitor | Size 0603 | Würth Elektronik | 885012206025 |
| C54,C58 | 1uF/10V | SMT ceramic capacitor | Size 0603 | Würth Elektronik | 885012206026 |
| C57 | 10nF/25V | SMT ceramic capacitor | Size 0603 | Würth Elektronik | 885012206065 |
| C61 | 100nF/50V | SMT ceramic capacitor | Size 0603 | Würth Elektronik | 885012206095 |
| C66 | 220pF/ 630V | SMT ceramic capacitor | Size 1206 | Multicomp | MC1206N221J631CT |
| C76 | 4.7uF/50V | SMT ceramic capacitor | Size 1206 | Würth Elektronik | 885012208094 |
| DL1,DL2 | Yellow | Yellow LED | Size 0603 | Würth Elektronik | 150060YS75000 |
| DL3 | Red | Red LED | Size 0603 | Würth Elektronik | 150060RS75000 |

| Reference | Part Value | Description | Package | Manufacturer | Part Number |
|------------------------------------|---------------------|---|---------------------|---|------------------|
| D1,D6,D11 | N.M. | Turbo 2 ultrafast high-voltage rectifier | SMA | STMicroelectronics | STTH1L06A |
| D2, D4, D7, D9, D12, D13, D19, D27 | BAT54J | 40 V, 300 mA small signal Schottky SMT Diode | SOD-323 | STMicroelectronics | BAT54JFILM |
| D20 | GBU805 | 8A glass passivated single-phase bridge rectifier | GBU | Taiwan Semiconductor or Diodes Incorporated | GBU805 or GBU806 |
| D21 | DDZ9690T | Surface mount Zener diode | SOD523 | Diodes Incorporated | DDZ9690T-7 |
| D22 | 3V3 N.M. | Zener | SOD-123 | | |
| D25 | STPS0560Z | 60V, 0.5A Schottky rectifier | SOD-123 | STMicroelectronics | STPS0560Z |
| D26 | STPS1150A | 150V, 1A Power Schottky rectifier | SMA | STMicroelectronics | STPS1150A |
| D28 | STTH1L06A | Turbo 2 ultrafast high-voltage Rectifier | SMA | STMicroelectronics | STTH1L06A |
| F1A | N.M. | Time-lag radial lead micro fuse, 250Vac | RST-Bel Fuse | Bel Fuse | 0697-xx |
| F1 | 10A/277V slow | Surface mount fuse, time-lag T, 250Vac/125Vdc | UMT250-Shurter | Schurter | 3403.0176.24 |
| JP1 | Closed 2-3 | SMT jumper | Soldering pad | | |
| JP2, JP3, JP4, JP5, JP6 | Closed | SMT jumper | Soldering pad | | |
| JP7 | Closed 2-4 | Jumper to solder | Soldering pads | | |
| JP8,JP9 | Closed 1-2 | Strip connector 3 pos, 2.54mm | 1x3 pins | Würth Elektronik | 61300311121 |
| JP10 | Open | SMT jumper | Size 0805 | | |
| JP11 | Open | SMT jumper | | | |
| JP13,JP14,JP15 | N.M. | | | | |
| J1,J7,J9 | STRIP 1x4 | Strip connector 4 pos, 2.54mm | 1x4 pins | Würth Elektronik | 61300411121 |
| J2 | MORSV-508-3 P_screw | Connector terminal block T.H. 3 positions 5.08mm | 3 poles, pitch 5.08 | Würth Elektronik | 691213510003 |
| J3 | STRIP 1x5 | Strip connector 5 pos, 2.54mm | 1x5 pins | Würth Elektronik | 61300511121 |
| J4 | MORSV-508-2 P_screw | Connector terminal block T.H. 2 positions 5.08mm | 2 poles, pitch 5.08 | Würth Elektronik | 691213510002 |
| J5 | 65100516121 | Mini USB 2.0 Type B SMD | USB mini B | Würth Elektronik | 65100516121 |
| TP6, J6, J8 | STRIP 1x2 | Strip connector 2 pos, 2.54mm | 1x2 pins | Würth Elektronik | 61300211121 |
| LD1 | Red-green | LED indicators, PLCC-4 red / yellow green | PLCC 4 | Avago | HSMF-A201-A00J1 |
| LD2 | Green | Green LED | Size 0805 | Würth Elektronik | 150080GS75000 |
| NTC1 | 2R2 | NTC thermistor for inrush current limiting | | TDK | B57236S0229M000 |
| Q1A, Q3A, Q4A, Q6A, Q7A, Q9A | N.M. | N-channel 600V, 0.195 Ohm typ., 15A MDmesh DM2 Power MOSFET | PowerFLAT 8x8 | STMicroelectronics | STL24N60DM2 |
| Q1, Q3, Q4, Q6, Q7, Q9 | STGD6M65DF 2 | Trench gate field-stop IGBT, M series 650V, 6A low loss | DPAK | STMicroelectronics | STGD6M65DF2 |
| Q10 | BC847 | General Purpose_45V_100mA_225mW | SOT23 | ON Semiconductor | BC847BL |

| Reference | Part Value | Description | Package | Manufacturer | Part Number |
|---|------------|---|---------------------|--------------------|----------------|
| Q12 | 3STF1640 | Low voltage high performance NPN power transistor | SOT-89 | STMicroelectronics | 3STF1640 |
| RV1 | N.M. | Varistor | Pitch 2.3x7.5mm | | |
| R1, R15, R35 | 27R | SMT resistor | Size 0805 | | |
| R2, R10, R16, R27, R40, R44 | 10R | SMT resistor | Size 0805 | | |
| R3, R13, R18, R30, R42, R45 | 100R | SMT resistor | Size 0805 | | |
| R5, R14, R19, R31, R43, R46, R105, R106 | 100K | SMT resistor | Size 0603 | | |
| R23 | 100K | Square trimpot trimming potentiometer | 3386H | Bourns | 3386H-1-104-LF |
| R26, R29, R73, R95, R97, R99, R101, R118, R119, R125 | 0R | SMT resistor | Size 0603 | | |
| R32 | 47K | SMT resistor | Size 0603 | | |
| R33, R53, R56 | 220m/1W/1% | SMT resistor | Size 2512 / 1210 | | |
| R41, R111, R114, R115, R120, R124 | 20K | SMT resistor | Size 0603 | | |
| R47 | 0R | SMT resistor | Size 0603 | | |
| R48 | 39K | SMT resistor | Size 0603 | | |
| R49, R52, R63, R64, R89, R90, R103 ,R116, R122 ,R126 | 10K | SMT resistor | Size 0603 | | |
| R50, R51, R57 | 1K | SMT resistor | Size 0603 | | |
| R54, R66, R79, R91, R102, R107, R108 | 100R | SMT resistor | Size 0603 | | |
| R55, R112, R113, R117, R121, R123 | 6K8 | SMT resistor | Size 0603 | | |
| R62,R77 | 120R | SMT resistor | Size 0603 | | |
| R67,R69 | 470K | SMT resistor | Size 1206 | | |
| R68,R70, R71 | 1.8K | SMT resistor | Size 0603 | | |
| R72 | N.M. | NTC resistor | Hole 0.8mm | | |
| R74,R75, R76, R104 | N.M. | SMT resistor | Size 0603 | | |
| R78 | 6.49K | SMT resistor | Size 0805 | | |
| R80 | 1K | SMT resistor | Size 0805 | | |
| R81, R94, R98, R100 | 4.7K | SMT resistor | Size 0603 | | |
| R82 | 330R | SMT resistor | Size 0603 | | |
| R83 | 0R | SMT resistor | Size 1206 | | |
| R84,R93 | 36K | SMT resistor | Size 0603 | | |

| Reference | Part Value | Description | Package | Manufacturer | Part Number |
|---|----------------------|--|---------------------------|--------------------|-----------------------------|
| R85 | 10R | SMT resistor | Size 0603 | | |
| R86,R87 | 22K | SMT resistor | Size 0603 | | |
| R88 | 1.5K | SMT resistor | Size 1206 | | |
| R92 | 1.5K | SMT resistor | Size 0603 | | |
| R96 | 2.7K | SMT resistor | Size 0603 | | |
| R110 | 220K 1/3W | SMT resistor | Size 0805 | TE Connectivity | CRGH0805J220K |
| R127 | 8K2 | SMT resistor | Size 0603 | | |
| R128,R129 | 33K | SMT resistor | Size 0603 | | |
| SW1,SW2, SW3 | 430483025816 | CMS tactile switches - 6x6 J-bend | | Würth Elektronik | 430483025816 |
| TP1 | TPHIN1 | Test point, PCB 1mm diameter | Copper pad | | |
| TP2 | TPHIN2 | Test point, PCB 1mm diameter | Copper pad | | |
| TP3 | TPHIN3 | Test point, PCB 1mm diameter | Copper pad | | |
| TP4, TP7, TP14, TP19, TP20, TP21, TP22, TP23, TP24, TP25, TP26, TP27, TP29 | N.M. | TP for probe | Diam. 1.27, hole 0.8mm | | |
| TP5 | PB8 | Test point, PCB 1mm diameter | Copper pad | | |
| TP8,TP12 | TPTH- ANELLO-1mm | THT ring test point | | Keystone | 5003 |
| TP15 | NEEDLE- PAD-1.7mm | Test point - PCB 1.7mm diameter | Copper pad | | |
| TP18 | PGND | Test point, PCB 1mm diameter | Copper pad | | |
| TP28 | PA12 | Test point, PCB 1mm diameter | Copper pad | | |
| T1 | 750318434 | Switch mode transformer 2.3W 60kHz 3.15mH 7-15V | | Würth Elektronik | 750318434 |
| U1 | STSPIN32F06 01 | 600V 3-phase controller with ARM Cortex MCU | TQFP64-10x10 x1.0 | STMicroelectronics | STSPIN32F0601/TR |
| U4 | LD1117S33CT R | 800mA, 3.3V adjustable and fixed low drop positive Voltage Regulator | SOT-223 | STMicroelectronics | LD1117S33CTR |
| U5 | VIPER06XS | Fixed-frequency VIPer plus family | SSO10 | STMicroelectronics | VIPER06XS |
| U6 | USBLC6-2SC6 | Very low capacitance ESD protection | SOT23-6L | STMicroelectronics | USBLC6-2SC6 / Y |
| U7 | LD3985M33R | 3.3V_150mA_ultra low drop Voltage Regulator | SOT23-5L | STMicroelectronics | LD3985M33R |
| U8 | STM32F103C BT6 | 64/182 KB Flash_USB_72MHz_3.6V | LQFP48 - 7x7mm | STMicroelectronics | STM32F103CBT6 |
| U10,U11 | TSV912IQ2T | Dual rail-to rail input/output 8MHz operational amplifiers | DFN8 2x2 | STMicroelectronics | TSV912IQ2T |
| X1,X2 | 8MHz | Crystal 8.0000MHz 8PF SMD | 2.5x3.2mm | NDK | NX3225GD-8MHZ-STD- CRA-3 |
| | | Rubber feet | | Hammond | 1421T6CL |
| J8,JP8,JP9 | | Female jumper isolated, pitch 2.54mm | | Assman WSW | AKSCT/Z Black |



| Reference | Part Value | Description | Package | Manufacturer | Part Number |
|-----------|------------|-----------------------------------|---------|--------------------|-------------|
| | | P.C.B. EVSPIN32F0601S3 rev.2.0 | | STMicroelectronics | |

4 Layout and component placements

Figure 5. EVSPIN32F0601S3 – Board functions description

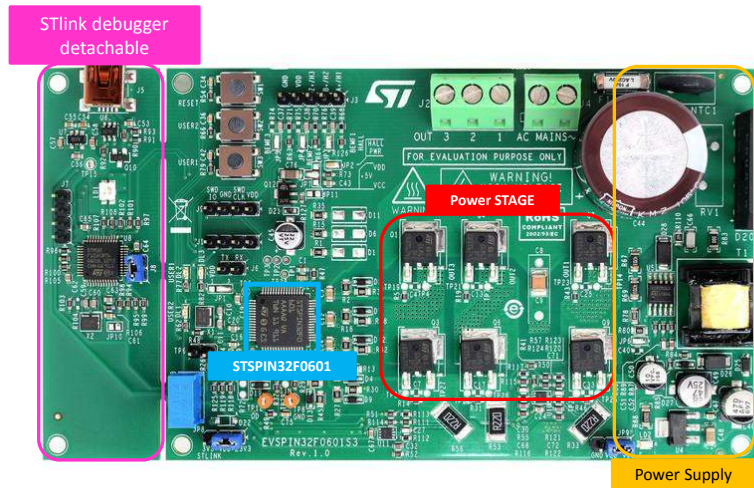

Warning:

The kit is not electrically isolated from the AC/DC input. The USB interface of the board does not insulate host computer from high voltage. When the board is supplied at a voltage outside the ELV range, a proper insulation method such as a USB isolator must be used to operate the board.

Figure 6. EVSPIN32F0601S3 – Layout (component placement top view)

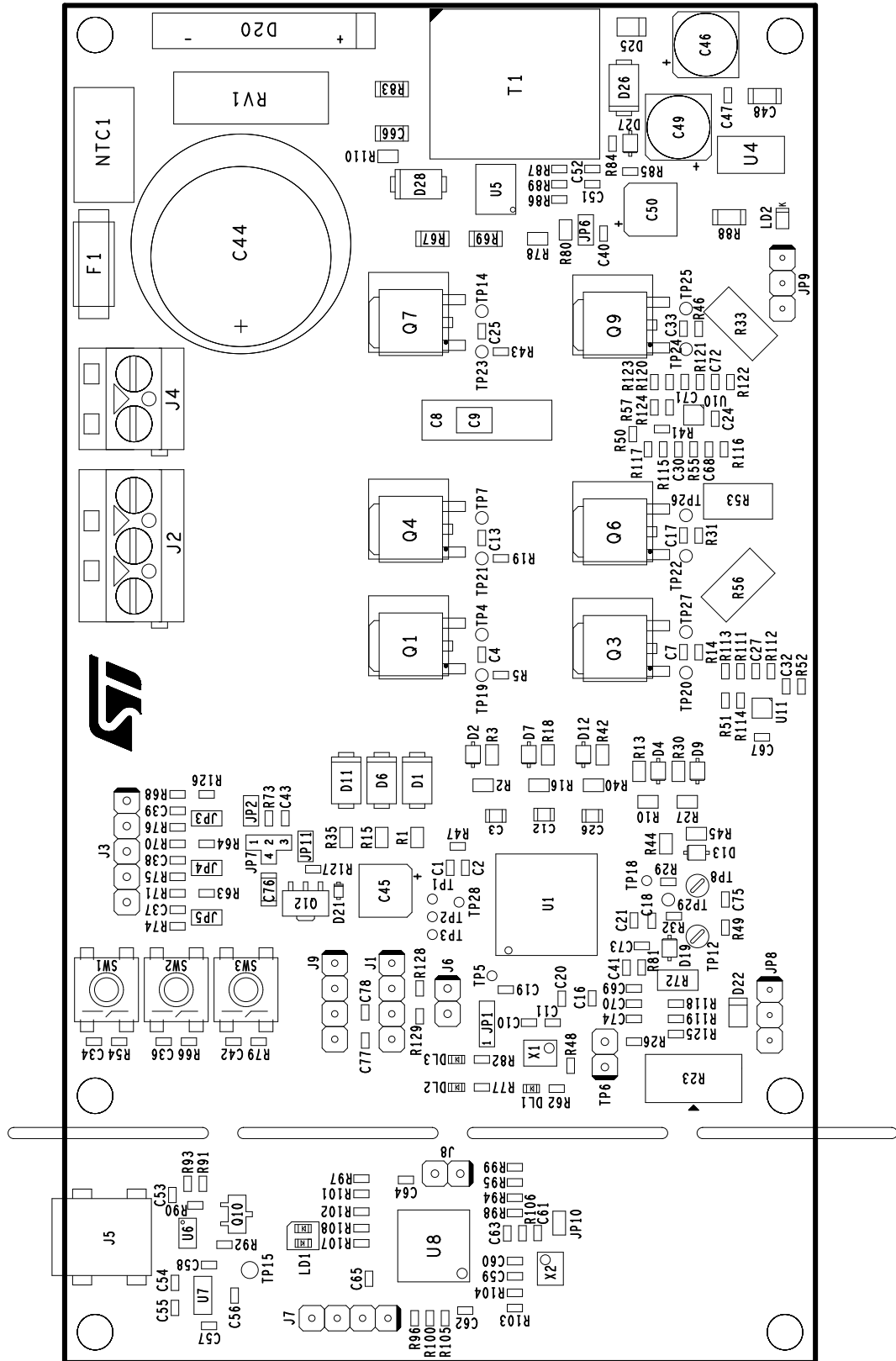

Figure 7. EVSPIN32F0601S3 – Layout (top layer)

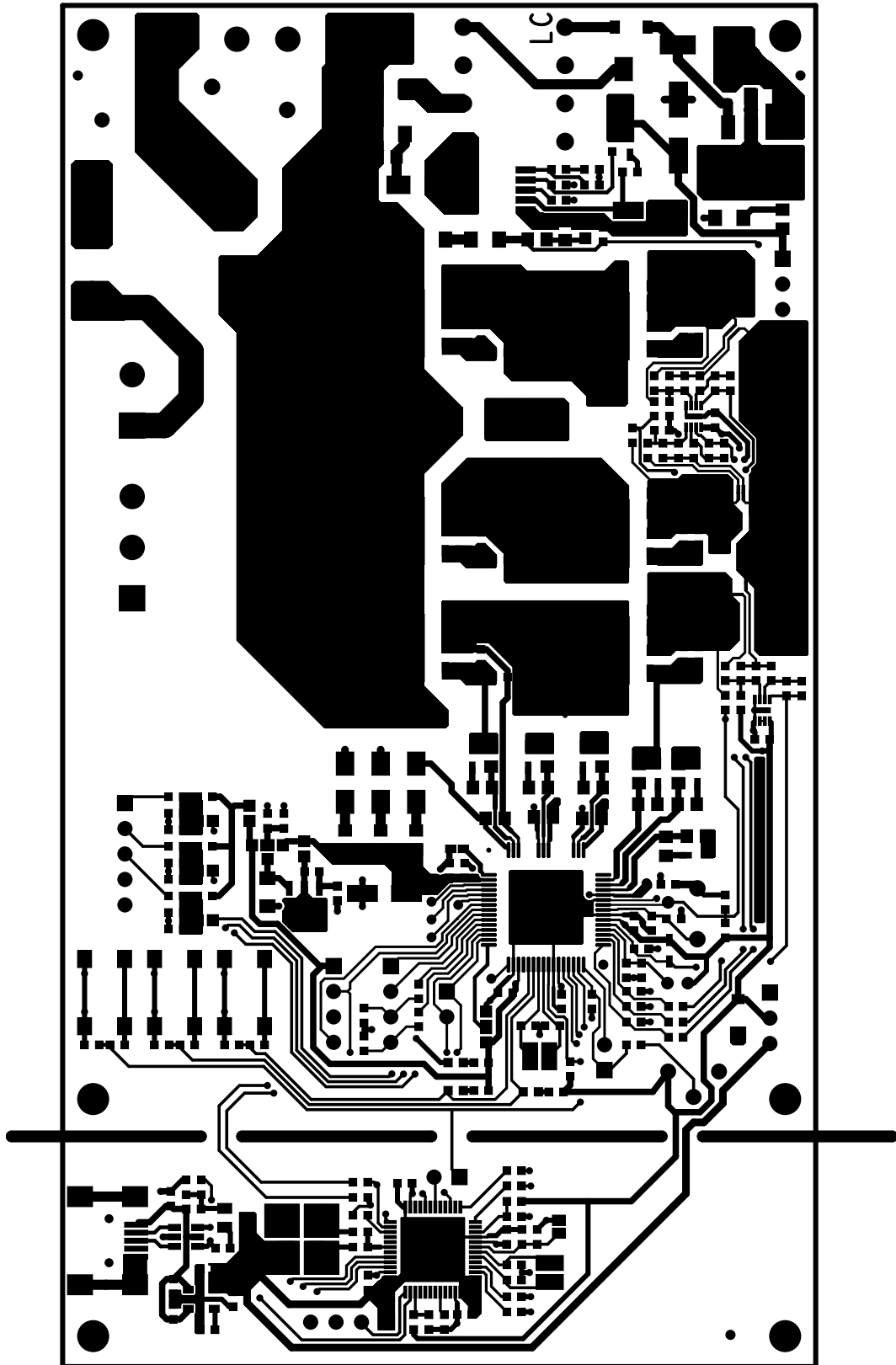
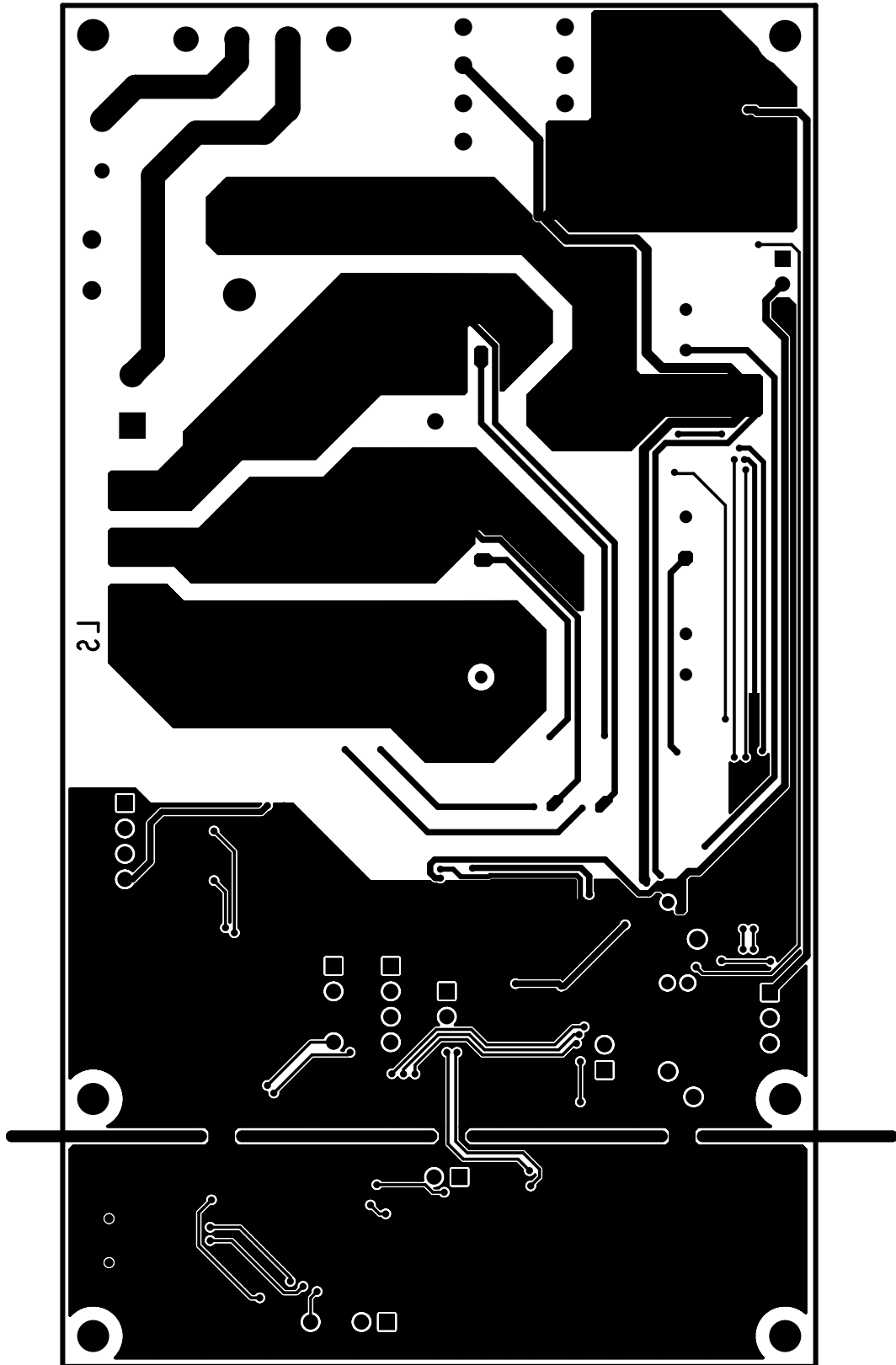

Figure 8. EVSPIN32F0601S3 – Layout (bottom layer)



Revision history

Table 2. Document revision history

| Date | Version | Changes |
|-------------|---------|------------------|
| 28-Oct-2019 | 1 | Initial release. |

Contents

| | | |
|----------|--|-----------|
| 1 | Safety and operating instructions | 3 |
| 1.1 | General terms | 3 |
| 1.2 | Intended use of evaluation board | 3 |
| 1.3 | Installing the evaluation board | 3 |
| 1.4 | Operating the evaluation board | 3 |
| 2 | Schematic diagram | 5 |
| 3 | Bill of Material | 9 |
| 4 | Layout and component placements | 14 |
| | Revision history | 18 |
| | Contents | 19 |
| | List of tables | 20 |
| | List of figures | 21 |

List of tables

| | | |
|-----------------|--|----|
| Table 1. | Bill of Materials – Components common to all device variants | 9 |
| Table 2. | Document revision history | 18 |

List of figures

| | | |
|------------------|--|----|
| Figure 1. | EVSPIN32F0601S3 schematic – Driver output stages | 5 |
| Figure 2. | EVSPIN32F0601S3 schematic – Feedback network | 6 |
| Figure 3. | EVSPIN32F0601S3 schematic – Power Supply | 7 |
| Figure 4. | EVSPIN32F0601S3 schematic – STLINK debugger | 8 |
| Figure 5. | EVSPIN32F0601S3 – Board functions description. | 14 |
| Figure 6. | EVSPIN32F0601S3 – Layout (component placement top view). | 15 |
| Figure 7. | EVSPIN32F0601S3 – Layout (top layer) | 16 |
| Figure 8. | EVSPIN32F0601S3 – Layout (bottom layer). | 17 |

IMPORTANT NOTICE – PLEASE READ CAREFULLY

STMicroelectronics NV and its subsidiaries (“ST”) reserve the right to make changes, corrections, enhancements, modifications, and improvements to ST products and/or to this document at any time without notice. Purchasers should obtain the latest relevant information on ST products before placing orders. ST products are sold pursuant to ST’s terms and conditions of sale in place at the time of order acknowledgement.

Purchasers are solely responsible for the choice, selection, and use of ST products and ST assumes no liability for application assistance or the design of Purchasers’ products.

No license, express or implied, to any intellectual property right is granted by ST herein.

Resale of ST products with provisions different from the information set forth herein shall void any warranty granted by ST for such product.

ST and the ST logo are trademarks of ST. For additional information about ST trademarks, please refer to www.st.com/trademarks. All other product or service names are the property of their respective owners.

Information in this document supersedes and replaces information previously supplied in any prior versions of this document.

© 2019 STMicroelectronics – All rights reserved