

PART NUMBER	REVISION	DESCRIPTION	FEED TYPE
2151060-1	J	FINE CRIMP HEIGHT ADJUST	MECHANICAL
2151060-2	K	FINE CRIMP HEIGHT ADJUST	PNEUMATIC
5-2151060-1	J	SEAL STRIPPER CRIMPER TERMINATING UNIT	MECHANICAL
5-2151060-2	K	SEAL STRIPPER CRIMPER TERMINATING UNIT	PNEUMATIC
7-2151060-1	J	MECHANICAL AND CRIMP TOOLING KIT	MECHANICAL
7-2151060-2	K	PNEUMATIC AND CRIMP TOOLING KIT	PNEUMATIC
7-2151060-7	G	CRIMP TOOLING KIT	-

ATLANTIC VERSION TERMINATOR INTERFACE ADAPTER

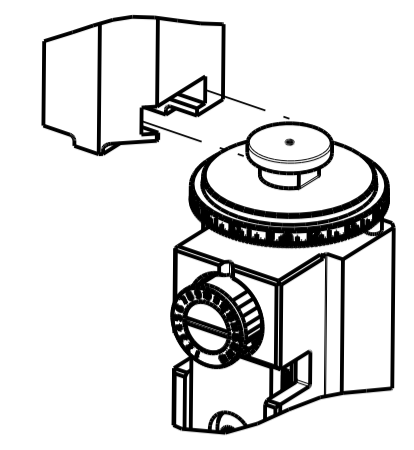

APPLICATOR DATA		
CRIMP	SIZE	TYPE
WIRE	2.03 mm [.080]	F
INSUL	4.06 mm [.160]	O

APPLICATOR INSTRUCTIONS 408-35042

TERMINAL DATA: TE TERMINAL		TE CRIMP SPECIFICATION	
TERMINAL NAME: AMP MCP 2.8K FLAT TYPE RECEPTACLE			
WIRE STRIP LENGTH		TERMINAL INSULATION DIAMETER RANGE	
3.70-4.30 mm [.146-.169 IN]		Ø1.40-2.70 mm [.055-.106 IN]	
TERMINAL APPLICATION SPECIFICATION	(C) 114-18387		

TERMINALS APPLIED				
TE TERMINAL	TE SEAL	BOSCH SEAL	SEAL INSULATION DIAMETER RANGE	
(C) 1241394-1	(C) 1241394-3	963294-1	(C)1928300599	Ø1.2-2.0mm
(C) 1241394-2		963293-1		Ø2.0-2.7mm
		1572276-1	1928300599	

TERMINAL DATA: TE TERMINAL		TE CRIMP SPECIFICATION	
TERMINAL NAME: JUNIOR-POWER-TIMER CONTACT			
WIRE STRIP LENGTH		TERMINAL INSULATION DIAMETER RANGE	
4.20-4.80 mm [.165-.189 IN]		Ø1.40-2.70 mm [.055-.106 IN]	
TERMINAL APPLICATION SPECIFICATION	(A) 114-18050	(C)114-18387	

TERMINALS APPLIED				
TE TERMINAL	TE SEAL	BOSCH SEAL	SEAL INSULATION DIAMETER RANGE	
(A) 964286-1	(A) 6-964286-6	963294-1		Ø1.2-2.0mm
(A) 964286-2	(B) 1-964300-3	963293-1		Ø2.0-2.7mm
(A) 1-964286-1	(B) 2-964300-1	1572276-1	1928300599	
(A) 2-964286-1	(B) 4-964300-1			
(A) 4-964286-1	(B) 2-964300-2			

WIRE SIZE	CRIMP HEIGHT mm [INCH]	CRIMP HEIGHT REFERENCE SETTING
1.00mm2	1.20+/-0.05 [.047+/- .002]	6.5
0.75mm2	1.18+/-0.05 [.046+/- .002]	6.9
0.50mm2	1.15+/-0.05 [.045+/- .002]	7.2

- 1 RECOMMENDED SPARE PARTS
 - 2 REFER TO SUPPLIED INSTRUCTION SHEET FOR CLEANING, LUBRICATION AND STORAGE OF APPLICATOR.
 - 3 APPLY PART NUMBER 1-23419-5 LOCTITE TO THREADS OF ITEM 180. APPLY PART NUMBER 2-23419-6 LOCTITE TO THREADS OF ITEM 242.
 - 4 CRIMP HEIGHT REFERENCE SETTING WAS THE SETTING USED WHEN THE APPLICATOR WAS QUALIFIED AT THE FACTORY. ADJUSTMENT MAY BE NECESSARY WHEN RUNNING APPLICATOR IN THE FIELD.
 - 5 APPLY TORQ-SEAL IN ALLEN SOCKET TO FILL HOLE AFTER FLAT HD HAS BEEN ADJUSTED TO CORRECT HEIGHT AT QUALIFICATION. APPLY #1-23419-5 LOC-TITE TO THREADS.
 - 6 TERMINAL LUBRICANT IS RECOMMENDED.
7. UNLESS SPECIFIED OTHERWISE TORQUE VALUES SHALL BE USED PER DOCUMENT, 101-35000.

***WARNING**
ON INSTALLATION, SET WIRE DISC TO CRIMP HEIGHT REFERENCE SETTING FOR LARGEST WIRE SIZE. CRIMP HEIGHT REFERENCE SETTINGS GREATER THAN THE VALUE SHOWN MAY CAUSE DAMAGE TO THE CRIMP TOOLING, REFER TO THE INSTRUCTION SHEET FOR PROPER SETUP AND ADJUSTMENTS.

LOC	DIST	REV	DATE	BY	CHKD	APPVD
A	66	H	29AUG2018	YY	CT	
		J	07DEC2018	FL	CT	
		K	02APR2019	LG	TE	
		K1	18JAN2021	FJ	YY	

-	-	-	1	1	-	-	1803515-3	RAM ASSEMBLY, SF ATLANTIC	293
-	-	-	1	1	-	-	2-1803583-1	APPLICATOR BASIC ASSEMBLY, SF	292
-	1	-	1	-	1	-	2119641-1	FEED CAM, AIR FEED	248
-	1	1	1	1	1	1	2119082-7	CAM, SNAIL, INSULATION ADJUSTMENT	244
-	1	1	1	1	1	1	2079764-1	WASHER, WAVE SPRING, CREST-TO-CREST	243
-	1	1	1	1	1	1	2119083-1	RETAINER, INSULATION DIAL	242
-	1	1	1	1	1	1	7-18023-7	SCR, SKT HD CAP M3 X 4.0	241
-	-	1	-	1	-	1	2119580-1	MECHANICAL FEED ASSEMBLY	239
-	1	-	1	-	1	-	2844940-1	AIR FEED MODULE	238
-	-	-	1	1	-	-	4-1722335-3	STRIPPER, SIDE FEED	182
-	-	-	1	1	-	-	1-5018030-0	NUT, HEX, REG, RoHS, M3.5	181
-	-	-	1	1	-	-	2-1752354-1	STANDOFF,HOLD-DOWN	180
-	-	-	1	1	-	-	9931111-1	PIN, SLOTTED SPRING 3.0 X 20.0	177
-	-	-	1	1	-	-	5-22280-0	SPRING, COMPRESSION	176
-	-	-	1	1	-	-	1752353-3	GUIDE PIN,HOLDDOWN	175
-	-	-	1	1	-	-	1901680-2	GUIDE PIN,HOLDDOWN	174
-	REF	REF	REF	REF	REF	REF	994970-2	COUNTER, MAGNETIC	164
-	1	1	1	1	1	1	2119955-1	ASSY, LUBRICATOR, SIDE FEED	113
-	1	1	1	1	1	1	2844908-1	SCREW, LOCKING	99
-	1	1	1	1	1	1	2844907-1	POST, LOCKING	98
-	1	1	1	1	1	1	455888-5	SPACER, CRIMPER	82
-	1	1	1	1	1	1	1803607-3	DOCUMENTATION PACKAGE	71
-	1	1	1	1	1	1	2119740-1	TAG, IDENTIFICATION	67
-	2	2	2	2	2	2	2168078-1	SCREW, DRIVE, RH, RoHS, 2 x .188	66
-	1	1	1	1	1	1	2168083-2	SCR, SKT HD CAP, RoHS, M4 X 8.0	60
-	1	1	1	1	1	1	5-18022-5	SCR, HEX HD CAP, M4 X 6.0	59
-	1	1	1	1	1	1	985575-3	SCR, FLT SKT HD CAP M3 X 10.0	57
-	1	1	1	1	1	1	1338685-1	PAWL, FEED	56
-	4	4	4	4	4	4	2168083-3	SCR, SKT HD CAP, RoHS, M4 X 12.0	54
-	2	2	2	2	2	2	2168083-3	SCR, SKT HD CAP, RoHS, M4 X 12.0	53
-	1	1	1	1	1	1	1803382-2	HOLD DOWN, SPRING LOADED	50
-	1	2	1	2	1	2	18023-9	SCR, SKT HD CAP M4 X 6.0	49
-	-	1	-	1	-	1	2119652-1	FEED CAM, PRE FEED	48
-	-	1	-	1	-	1	2119653-1	FEED CAM, POST FEED	47
-	1	1	-	1	1	1	1803583-9	APPLICATOR BASIC ASSEMBLY, SF	46
-	1	1	-	1	1	1	1803515-1	RAM ASSEMBLY, SF ATLANTIC	44
-	1	1	1	1	1	1	1803602-1	SCR, BHSC, RoHS (M8 X 25)	41
-	1	1	1	1	1	1	1-1752356-7	SUPPORT, TERMINAL	34
-	2	2	2	2	2	2	2079383-5	SCR, BHSC, RoHS (M4 X 20)	33
-	2	2	2	2	2	2	3-2844962-0	SPACER, CYLINDRICAL, STRIP GUIDE	30
-	1	1	1	1	1	1	2844992-2	ASSEMBLY, STRIP GUIDE	29
-	1	1	1	1	1	1	455888-4	SPACER, CRIMPER	28
-	1	1	1	1	1	1	1320928-6	STRIP GUIDE	24
-	1	1	-	-	1	1	2168083-2	SCR, SKT HD CAP, RoHS, M4 X 8.0	21
-	2	2	1	1	2	2	1-18028-2	WASHER, FLAT, REG M4	20
-	1	1	-	-	1	1	2119533-1	STRIPPER, SIDE FEED	19
-	1	1	1	1	1	1	2119806-1	INSERT, SHEAR	13
-	1	1	1	1	1	1	3-22280-3	SPRING, COMPRESSION	12
-	1	1	1	1	1	1	1-356885-4	STOP, SHEAR	11
-	1	1	1	1	1	1	2119805-1	SHEAR HOLDER, FRONT	10
-	1	1	1	1	1	1	318707-1	FLOATING SHEAR, FRONT	9
1	2	2	1	1	1	1	1333204-4	ANVIL, COMBINATION	8
-	1	1	1	1	1	1	5-240641-4	SPACER	7
-	1	1	1	1	1	1	2119781-1	DEPRESSOR, SHEAR	5
-	1	1	1	1	1	1	238011-9	BLOCK, CRIMPER SPACER	4
1	2	2	1	1	1	1	2-1803019-4	CRIMPER, INSULATION O	3
-	1	1	1	1	1	1	455888-5	SPACER, CRIMPER	2
1	2	2	1	1	1	1	1803125-9	CRIMPER, WIRE	1

ATLANTIC VERSION
Shown on sheets 1 of 4 & 2 of 4
(Pacific version shown on sheets 3 of 4 & 4 of 4)

DIMENSIONS:		TOLERANCES UNLESS OTHERWISE SPECIFIED:		DWG: HOFFNER 26AUG2011		CHK: T.ELBIN 29AUG2011		APPVD: T.ELBIN 29AUG2011		NAME: Ocean Side Feed Applicator	
mm	0 PLC ±	1 PLC ±	2 PLC ±	3 PLC ±	4 PLC ±	ANGLES ±	FINISH	WEIGHT	SCALE: 1:2	SHEET 1 OF 4	REV: K1
MATERIAL								Customer Accessible Production Drawing		RESTRICTED TO	

LOC	DIST	REV	DATE	BY	CHKD	APVD
A	66					

FEED TYPE MECHANICAL

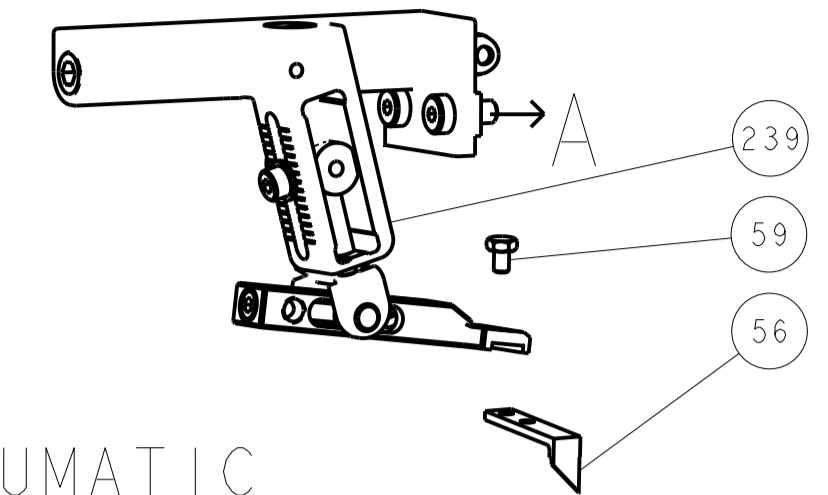

PNEUMATIC

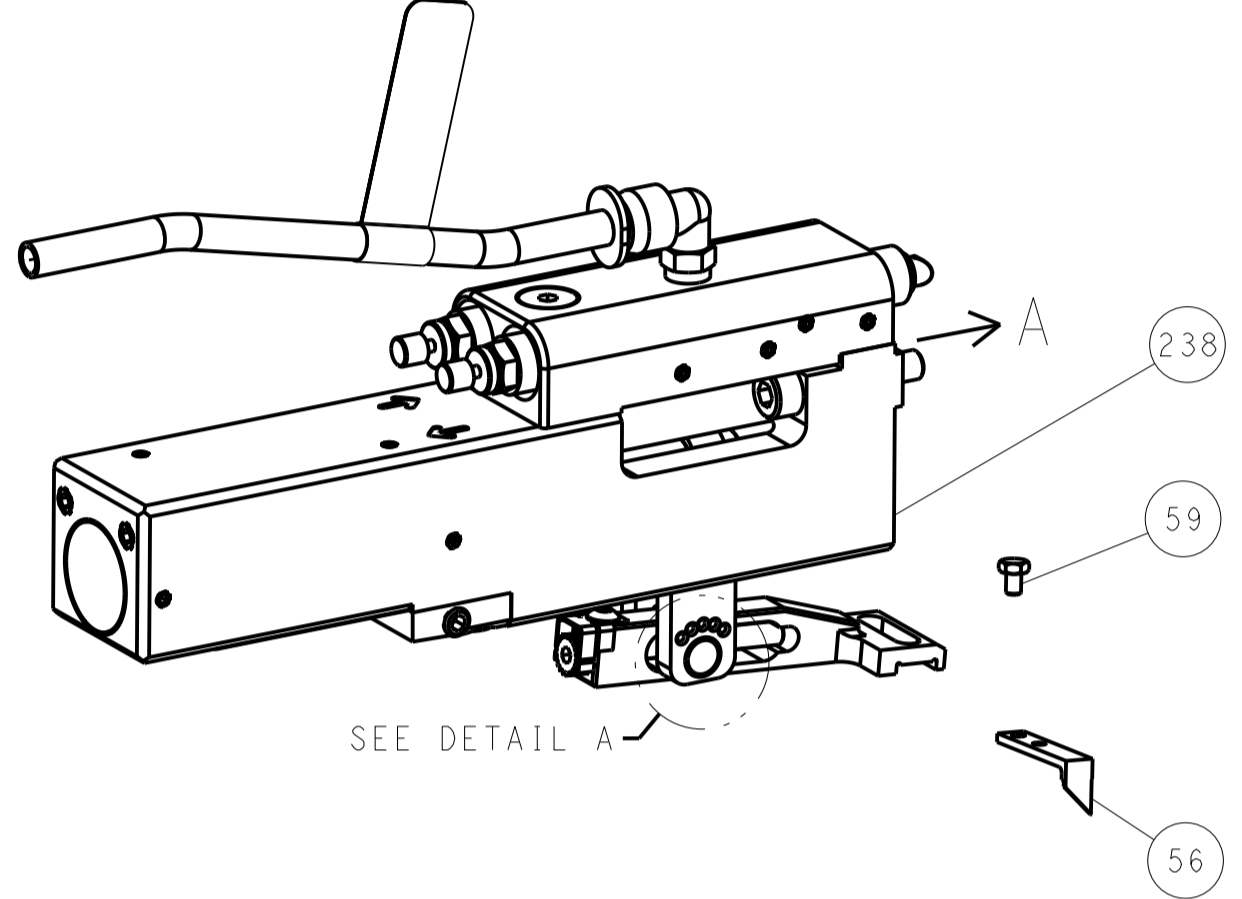

FEED SPRING SETTING POSITION (SHOWN FROM REAR SIDE)

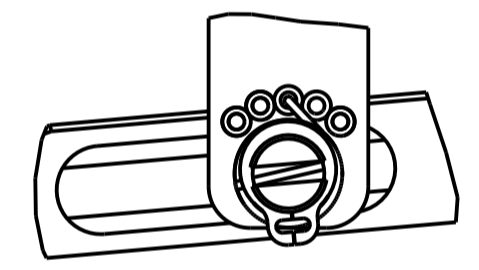

DETAIL A

CAM POSITIONS

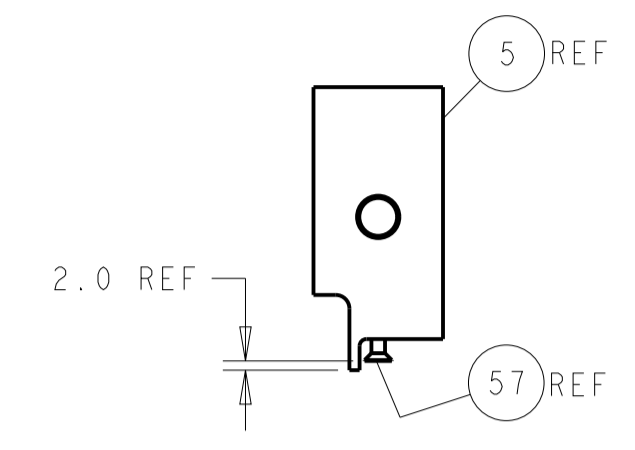
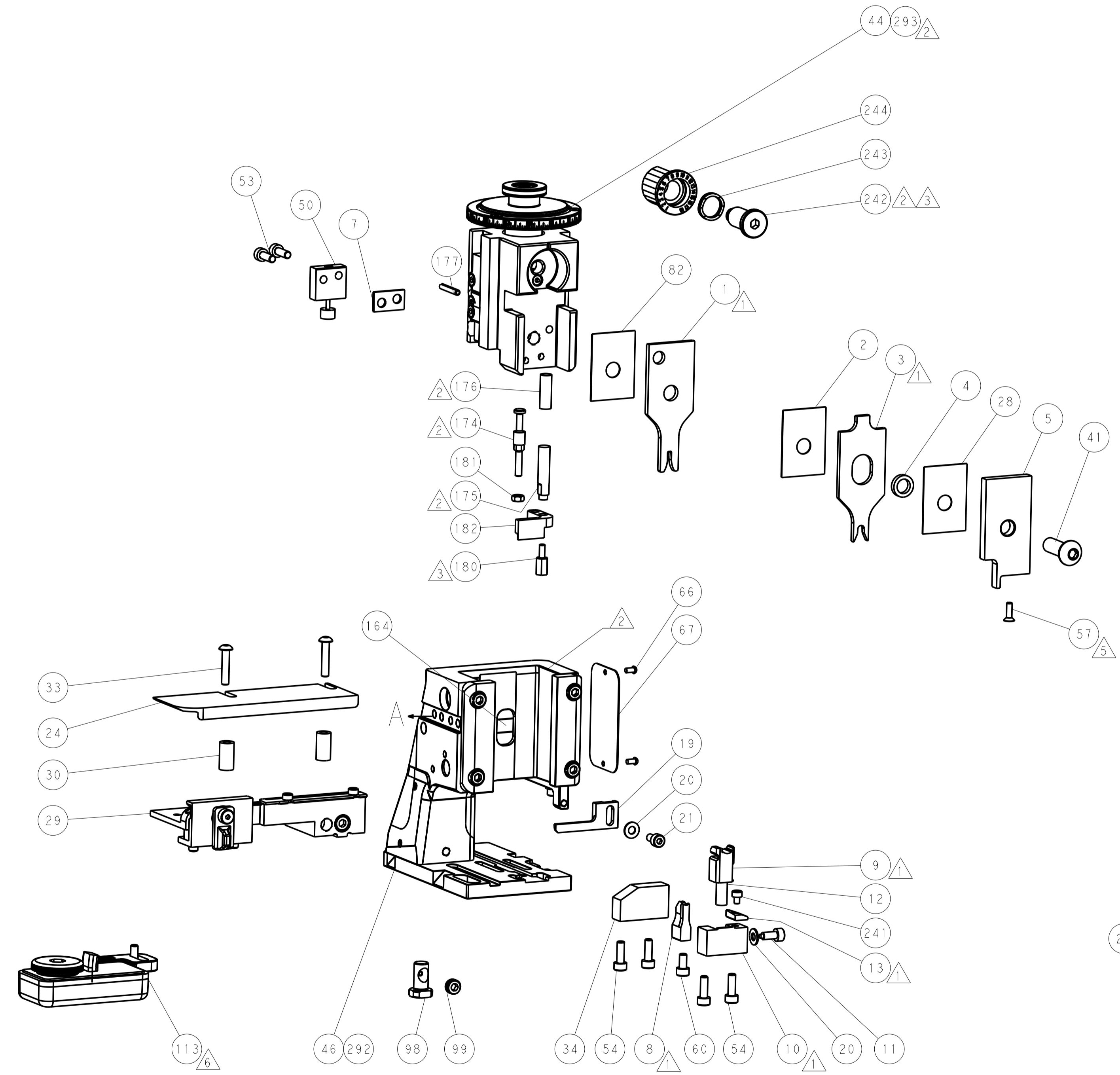
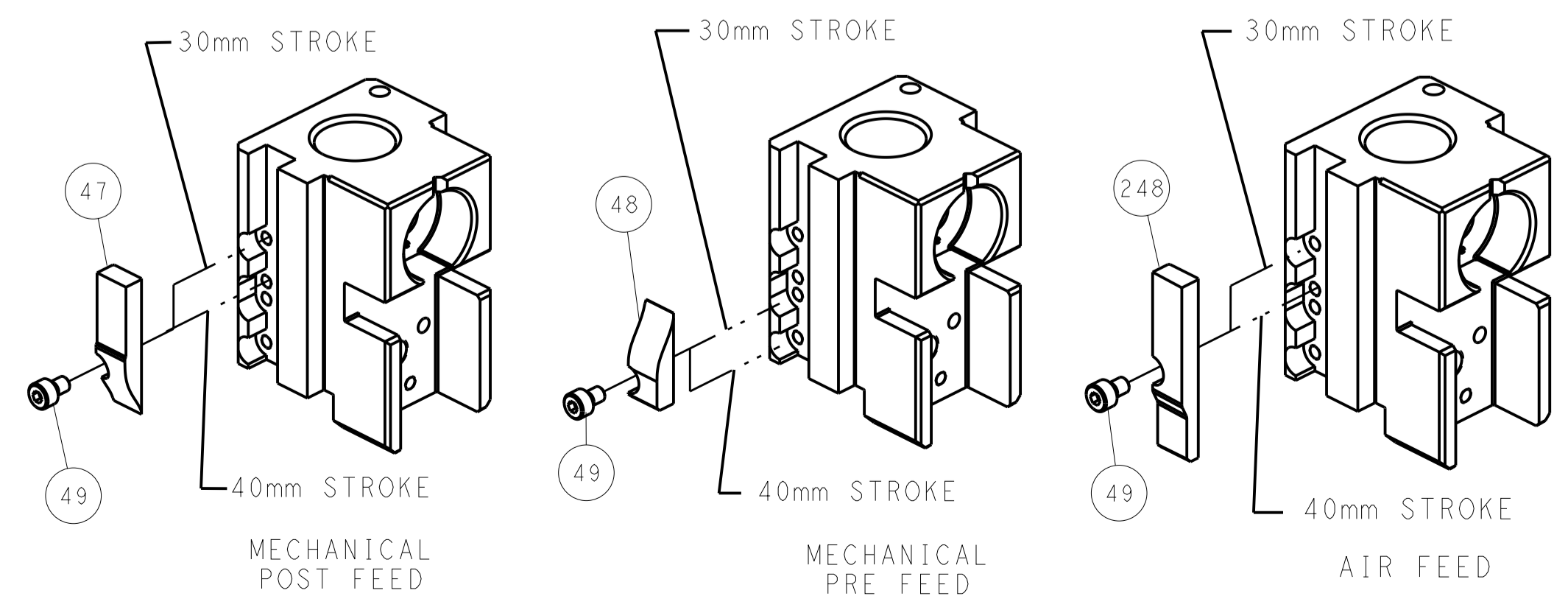

SHEAR DEPRESSOR DETAIL

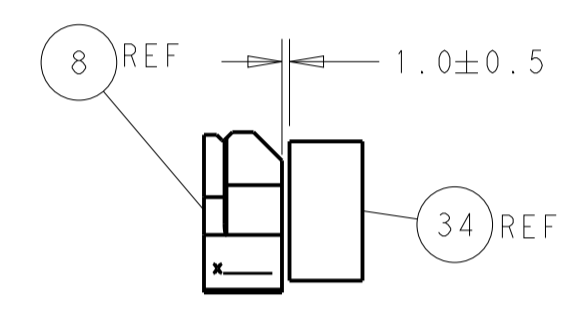

TERMINAL SUPPORT LOCATION

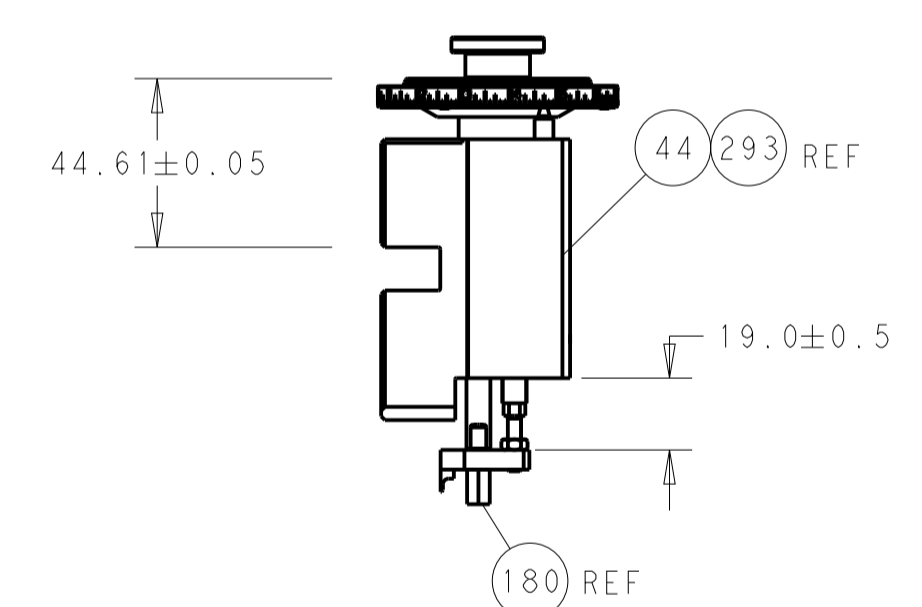

RAM AND HOLD DOWN SET-UP

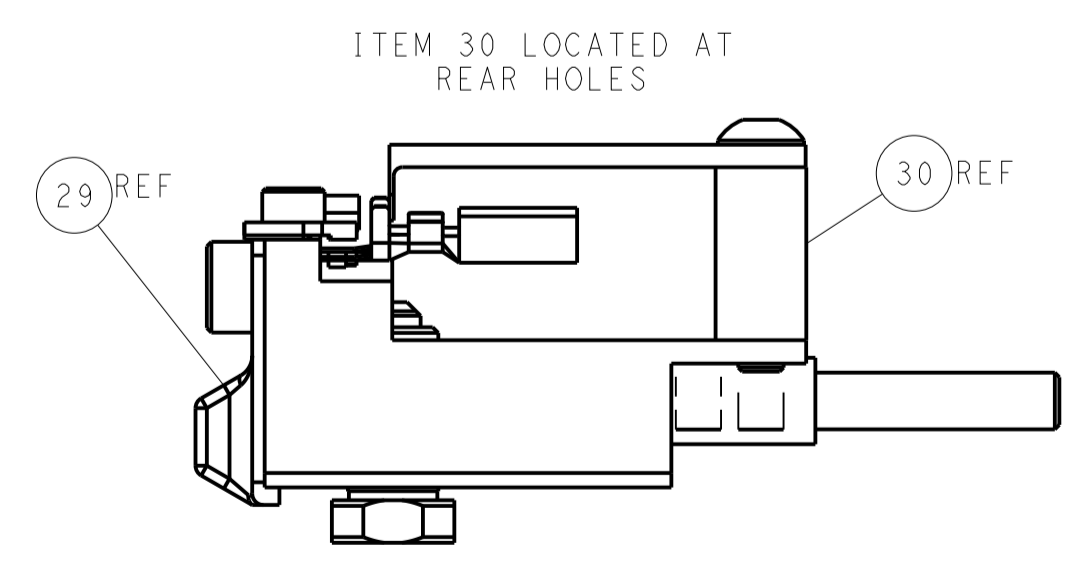

FEED TRACK POSITION GUIDE BY INSULATION BARREL

ATLANTIC VERSION
 Shown on sheets 1 of 4 & 2 of 4
 (Pacific version shown on sheets 3 of 4 & 4 of 4)

DIMENSIONS: mm TOLERANCES UNLESS OTHERWISE SPECIFIED: 0 PLC ± 1 PLC ± 2 PLC ± 3 PLC ± 4 PLC ± ANGLES ±		DWN: HOFFNER 26AUG2011 CHK: T. ELBIN 29AUG2011 APVD: T. ELBIN 29AUG2011		NAME: Ocean Side Feed Applicator SIZE: A1 CAGE CODE: 00779 DRAWING NO: 2151060 SCALE: 1:2 SHEET: 2 of 4 REV: K1	
MATERIAL: - FINISH: -		PRODUCT SPEC: - APPLICATION SPEC: - WEIGHT: -		RESTRICTED TO: - CUSTOMER ACCESSIBLE PRODUCTION DRAWING	

PART NUMBER	REVISION	DESCRIPTION	FEED TYPE
2-2151060-1	J	FINE CRIMP HEIGHT ADJUST	MECHANICAL
2-2151060-2	K	FINE CRIMP HEIGHT ADJUST	PNEUMATIC
7-2151060-7	G	CRIMP TOOLING KIT	-

PACIFIC VERSION TERMINATOR
 INTERFACE ADAPTER

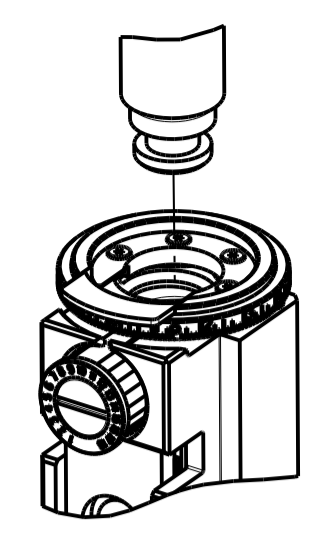

APPLICATOR DATA		
CRIMP	SIZE	TYPE
WIRE	2.03 mm [.080]	F
INSUL	4.06 mm [.160]	O

APPLICATOR INSTRUCTIONS
 408-35042

TERMINAL DATA: TE TERMINAL		TE CRIMP SPECIFICATION	
TERMINAL NAME: AMP MCP 2.8K FLAT TYPE RECEPTACLE			
WIRE STRIP LENGTH	3.70-4.30 mm [1.46-.169 IN]	TERMINAL INSULATION DIAMETER RANGE	∅1.40-2.70 mm [0.055-.106 IN]
TERMINAL APPLICATION SPECIFICATION	(C) 114-18387		

TERMINALS APPLIED				SEAL INSULATION DIAMETER RANGE
TE TERMINAL	TE TERMINAL	TE SEAL	BOSCH SEAL	
(C) 1241394-1	(C) 1241394-3	963294-1	(C)1928300599	∅1.2-2.0mm
(C) 1241394-2		963293-1		∅2.0-2.7mm
		1572276-1	1928300599	

TERMINAL DATA: TE TERMINAL		TE CRIMP SPECIFICATION	
TERMINAL NAME: JUNIOR-POWER-TIMER CONTACT			
WIRE STRIP LENGTH	4.20-4.80 mm [1.65-.189 IN]	TERMINAL INSULATION DIAMETER RANGE	∅1.40-2.70 mm [0.055-.106 IN]
TERMINAL APPLICATION SPECIFICATION	(A) 114-18050	(C)114-18387	
	(B) 114-18051		

TERMINALS APPLIED				SEAL INSULATION DIAMETER RANGE
TE TERMINAL	TE TERMINAL	TE SEAL	BOSCH SEAL	
(A) 964286-1	(A) 6-964286-6	963294-1		∅1.2-2.0mm
(A) 964286-2	(B) 1-964300-3	963293-1		∅2.0-2.7mm
(A) 1-964286-1	(B) 2-964300-1	1572276-1	1928300599	
(A) 2-964286-1	(B) 4-964300-1			
(A) 4-964286-1	(B) 2-964300-2			

WIRE SIZE	CRIMP HEIGHT mm [INCH]	CRIMP HEIGHT REFERENCE SETTING
1.00mm2	1.20 +/- 0.05 [0.047 +/- .002]	6.5
0.75mm2	1.18 +/- 0.05 [0.046 +/- .002]	6.9
0.50mm2	1.15 +/- 0.05 [0.045 +/- .002]	7.2

- 1. RECOMMENDED SPARE PARTS
- 2. REFER TO SUPPLIED INSTRUCTION SHEET FOR CLEANING, LUBRICATION AND STORAGE OF APPLICATOR.
- 3. APPLY PART NUMBER 2-23419-6 LOCTITE TO THREADS OF ITEM 242.
- 4. CRIMP HEIGHT REFERENCE SETTING WAS THE SETTING USED WHEN THE APPLICATOR WAS QUALIFIED AT THE FACTORY. ADJUSTMENT MAY BE NECESSARY WHEN RUNNING APPLICATOR IN THE FIELD.
- 5. APPLY TORQ-SEAL IN ALLEN SOCKET TO FILL HOLE AFTER FLAT HD HAS BEEN ADJUSTED TO CORRECT HEIGHT AT QUALIFICATION. APPLY #1-23419-5 LOC-TITE TO THREADS.
- 6. TERMINAL LUBRICANT IS RECOMMENDED.
- 7. UNLESS SPECIFIED OTHERWISE TORQUE VALUES SHALL BE USED PER DOCUMENT, 101-35000.

***WARNING**
 ON INSTALLATION, SET WIRE DISC TO CRIMP HEIGHT REFERENCE SETTING FOR LARGEST WIRE SIZE. CRIMP HEIGHT REFERENCE SETTINGS GREATER THAN THE VALUE SHOWN MAY CAUSE DAMAGE TO THE CRIMP TOOLING, REFER TO THE INSTRUCTION SHEET FOR PROPER SETUP AND ADJUSTMENTS.

ENTRY LEVEL APPLICATOR		ITEM SUBSTITUTION LIST		
PART NUMBER	SAME AS	ITEM	ITEM DESCRIPTION	SUBSTITUTE PART NUMBER
8-2151060-1	2151060-1	1	WIRE CRIMPER	1803531-9
8-2151060-2	2151060-2	3	INSULATION CRIMPER	2-1803627-4
9-2151060-1	2-2151060-1	46	BASIC SUB -ASSEMBLY	1803940-9
9-2151060-2	2-2151060-2	141	BASIC SUB -ASSEMBLY	1-1803940-0
			LUBRICATOR	DELETE

PACIFIC VERSION
 Shown on sheets 3 of 4 & 4 of 4
 (Atlantic version shown on sheets 1 of 4 & 2 of 4)

LOC	DIST	REV	DATE	BY	APPV
A	66				

REV	DATE	DESCRIPTION	DATE	BY	APPV
-	1	1	2119082-7	CAM, SNAIL, INSULATION ADJUSTMENT	244
-	1	1	2079764-1	WASHER, WAVE SPRING, CREST-TO-CREST	243
-	1	1	2119083-1	RETAINER, INSULATION DIAL	242
-	1	1	7-18023-7	SCR, SKT HD CAP M3 X 4.0	241
-	-	1	2119580-1	MECHANICAL FEED ASSEMBLY	239
-	1	-	2844940-1	AIR FEED MODULE	238
-	REF	REF	994970-2	COUNTER, MAGNETIC	164
-	1	-	2119641-2	FEED CAM, AIR FEED	151
-	1	1	2168083-8	SCR, SKT HD CAP, RoHS, M4 X 16	144
-	4	4	2168083-9	SCR, SKT HD CAP, RoHS, M4 X 20	143
-	-	1	2119653-2	FEED CAM, POST FEED	142
-	1	1	1-1803583-0	APPLICATOR BASIC ASSEMBLY, SF	141
-	1	1	1803516-1	RAM ASSEMBLY, SF PACIFIC	140
-	1	1	2119955-1	ASSY, LUBRICATOR, SIDE FEED	113
-	1	1	2844908-1	SCREW, LOCKING	99
-	1	1	2844907-1	POST, LOCKING	98
-	1	1	455888-5	SPACER, CRIMPER	82
-	1	1	1803607-3	DOCUMENTATION PACKAGE	71
-	1	1	2119740-1	TAG, IDENTIFICATION	67
-	2	2	2168078-1	SCREW, DRIVE, RH, RoHS, 2 x .188	66
-	1	1	5-18022-5	SCR, HEX HD CAP, M4 X 6.0	59
-	1	1	985575-3	SCR, FLT SKT HD CAP M3 X 10.0	57
-	1	1	1338685-1	PAWL, FEED	56
-	2	2	2168083-3	SCR, SKT HD CAP, RoHS, M4 X 12.0	53
-	1	1	1803382-2	HOLD DOWN, SPRING LOADED	50
-	1	2	18023-9	SCR, SKT HD CAP M4 X 6.0	49
-	-	1	2119652-1	FEED CAM, PRE FEED	48
-	1	1	1803602-1	SCR, BHSC, RoHS (M8 X 25)	41
-	1	1	1-1752356-7	SUPPORT, TERMINAL	34
-	2	2	2079383-5	SCR, BHSC, RoHS (M4 X 20)	33
-	2	2	3-2844962-0	SPACER, CYLINDRICAL, STRIP GUIDE	30
-	1	1	2844992-2	ASSEMBLY, STRIP GUIDE	29
-	1	1	455888-4	SPACER, CRIMPER	28
-	1	1	1320928-6	STRIP GUIDE	24
-	1	1	2168083-2	SCR, SKT HD CAP, RoHS, M4 X 8.0	21
-	2	2	1-18028-2	WASHER, FLAT, REG M4	20
-	1	1	2119533-1	STRIPPER, SIDE FEED	19
-	1	1	2119806-1	INSERT, SHEAR	13
-	1	1	3-22280-3	SPRING, COMPRESSION	12
-	1	1	1-356885-4	STOP, SHEAR	11
-	1	1	2119805-1	SHEAR HOLDER, FRONT	10
-	1	1	318707-1	FLOATING SHEAR, FRONT	9
1	1	1	1333204-4	ANVIL, COMBINATION	8
-	1	1	5-240641-4	SPACER	7
-	1	1	2119781-1	DEPRESSOR, SHEAR	5
-	1	1	238011-9	BLOCK, CRIMPER SPACER	4
1	1	1	2-1803019-4	CRIMPER, INSULATION O	3
-	1	1	455888-5	SPACER, CRIMPER	2
1	1	1	1803125-9	CRIMPER, WIRE	1

DIMENSIONS: mm		TOLERANCES UNLESS OTHERWISE SPECIFIED:		DWG: HOFFNER 26AUG2011		REV: T.ELBIN 29AUG2011	
0 PLC	±	0.00	±	NAME	Ocean Side Feed Applicator		
1 PLC	±	0.01	±	PRODUCT SPEC	-		
2 PLC	±	0.02	±	APPLICATION SPEC	-		
3 PLC	±	0.03	±	SIZE	A1		
4 PLC	±	0.04	±	CAGE CODE	00779		
ANGLES	±	0.05	±	DRAWING NO	C=2151060		
FINISH	±	0.06	±	RESTRICTED TO	-		
MATERIAL				WEIGHT	Customer Accessible Production Drawing		SCALE 1:2 SHEET 3 OF 4 REV K1

LOC	DIST	REV	DATE	BY	APPV
A	66				
REVISIONS			DESCRIPTION	DATE	BY
			SEE SHEET 1		

FEED TYPE MECHANICAL

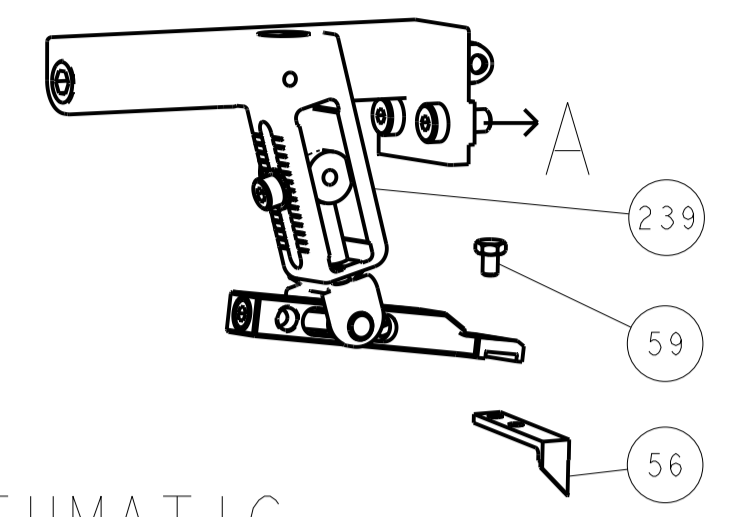

PNEUMATIC

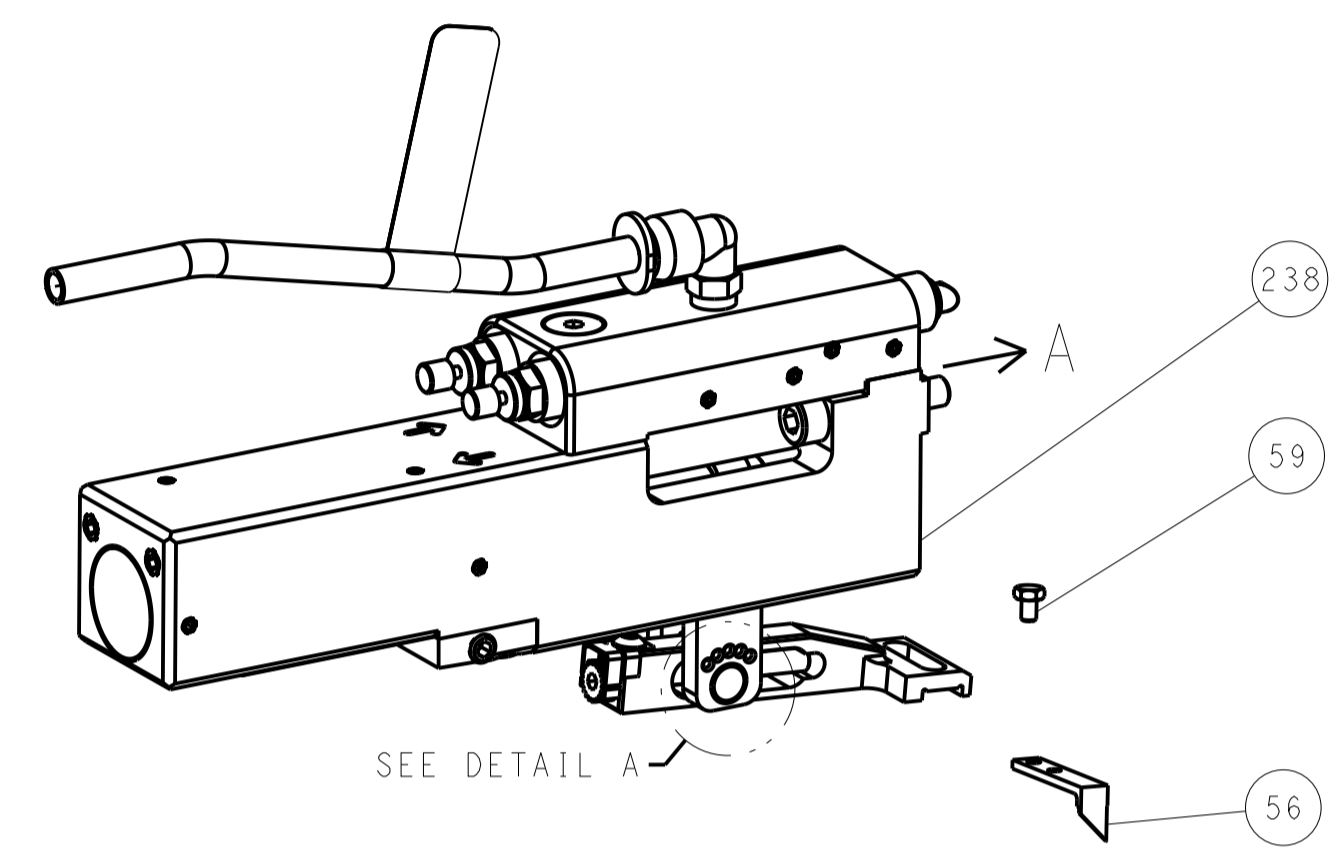

FEED SPRING SETTING POSITION (SHOWN FROM REAR SIDE)

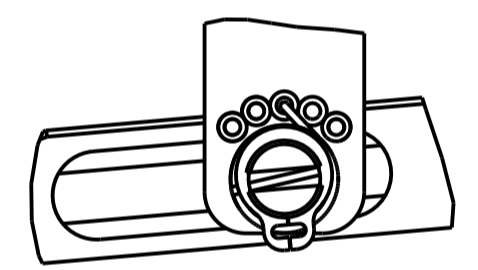

DETAIL A

CAM POSITIONS

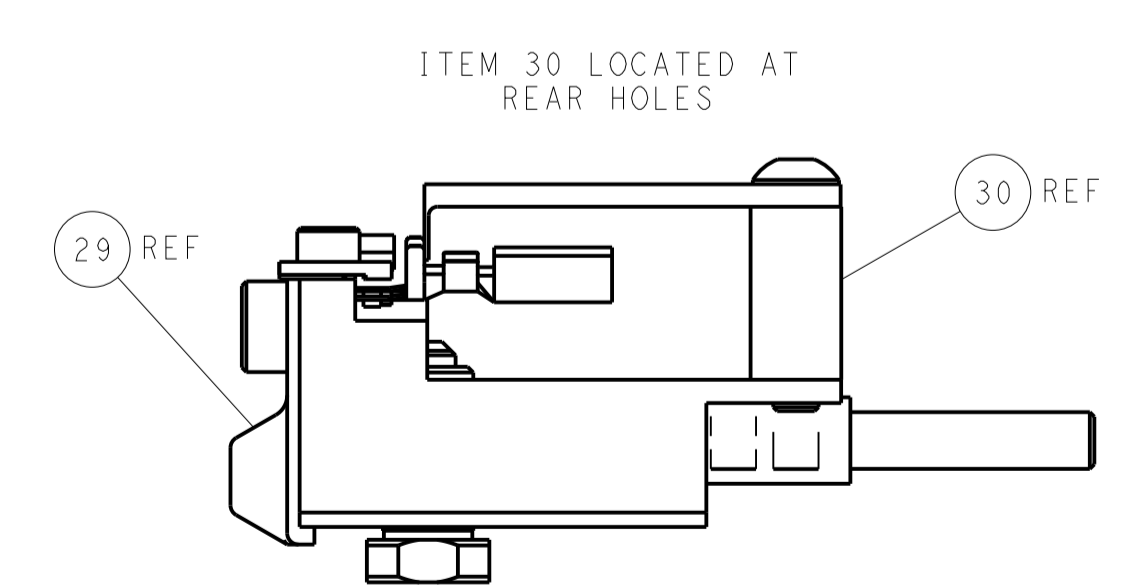
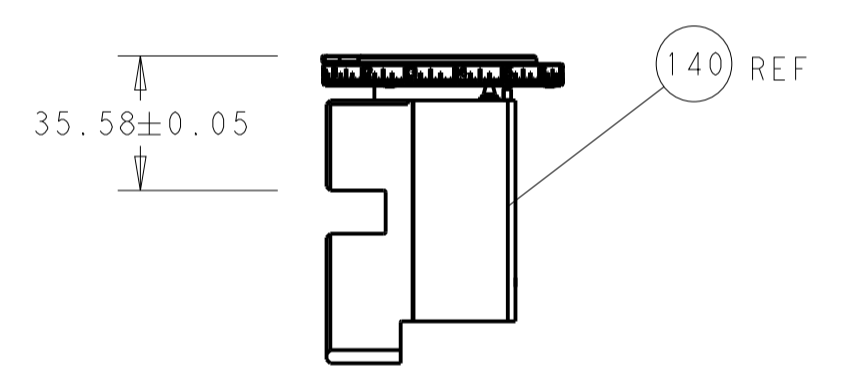
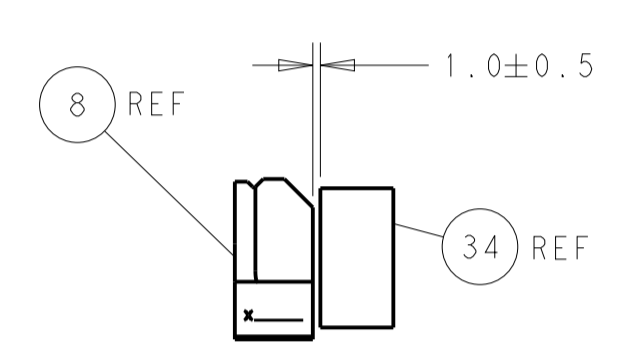
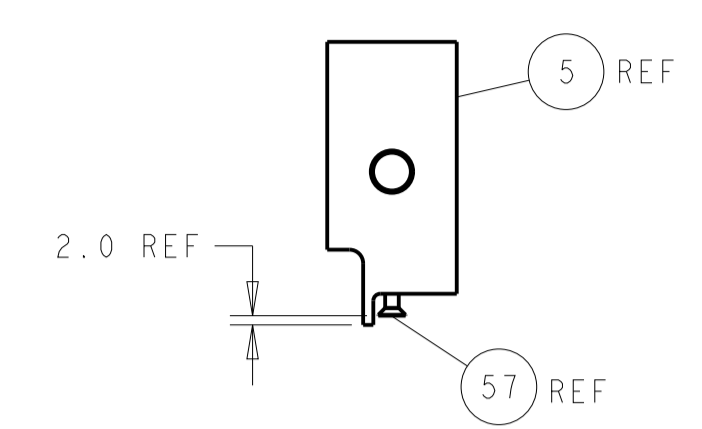
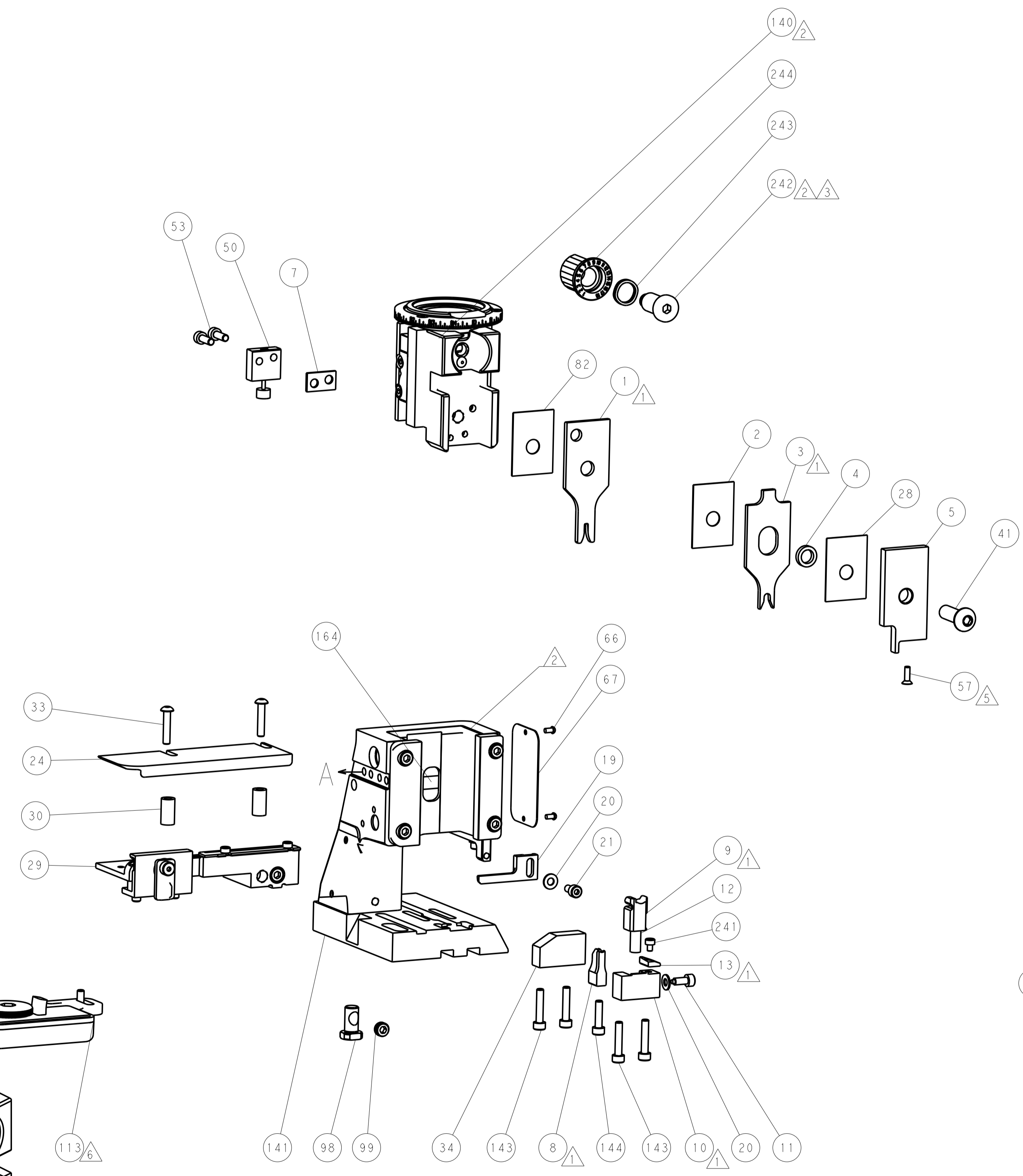
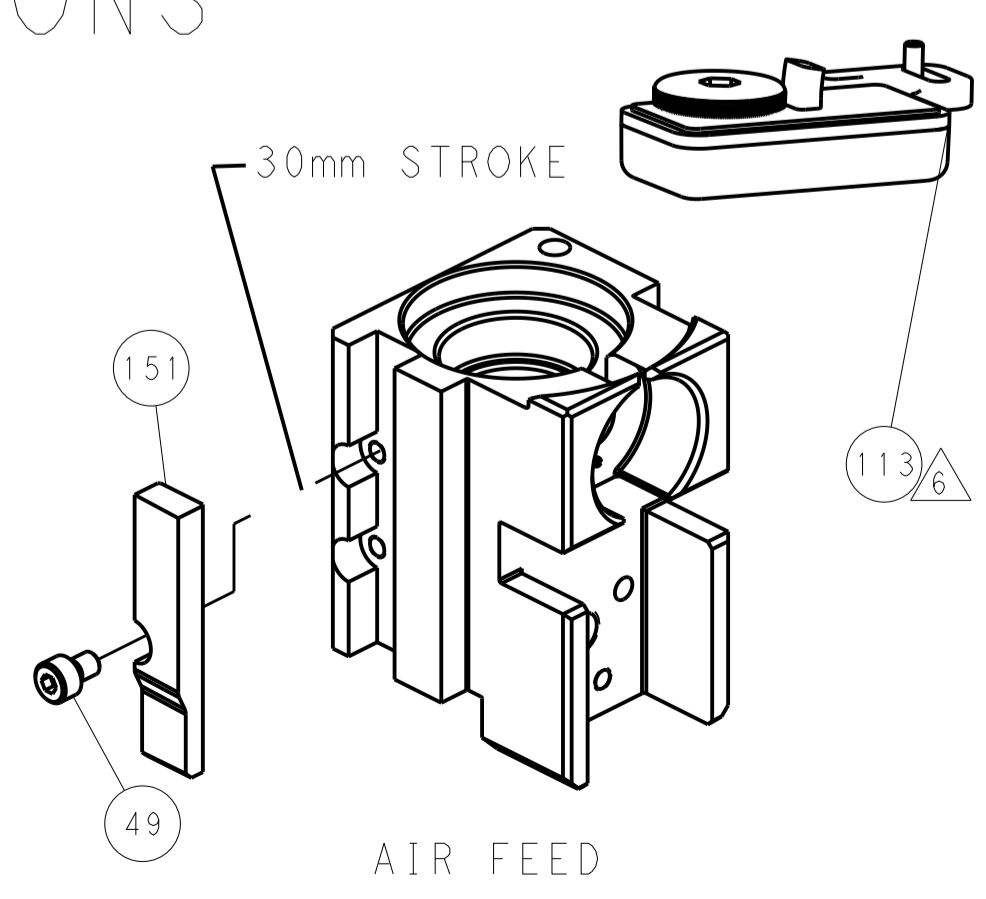
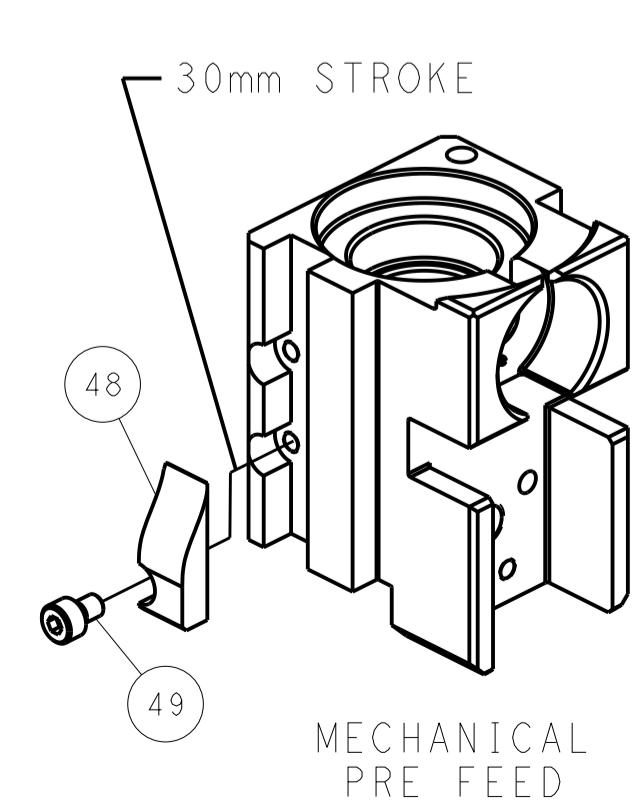
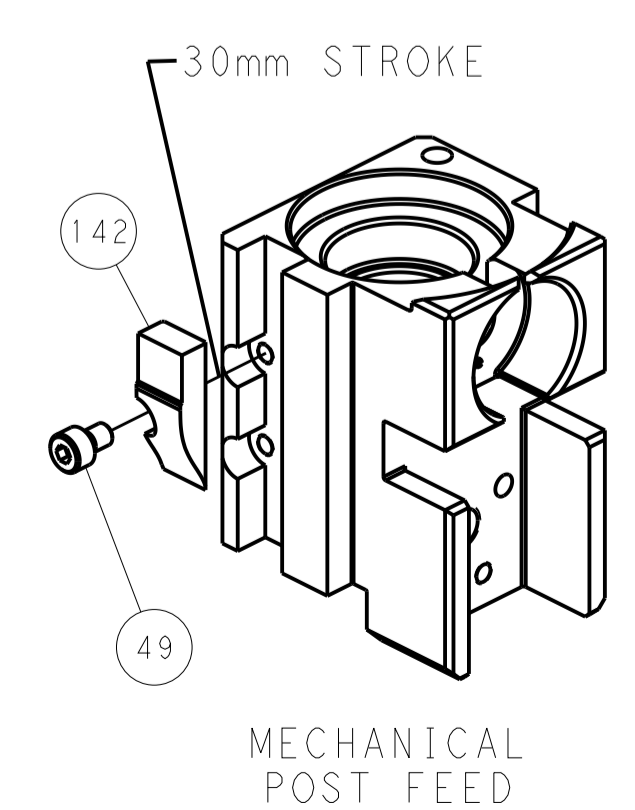

PACIFIC VERSION
 Shown on sheets 3 of 4 & 4 of 4
 (Atlantic version shown on sheets 1 of 4 & 2 of 4)

DIMENSIONS:		TOLERANCES UNLESS OTHERWISE SPECIFIED:		DWG: HOFFNER 26AUG2011		TE Connectivity	
mm	0 PLC	±		CHK: T. ELBIN 29AUG2011	NAME		Harrisburg, PA 17105-3608
	1 PLC	±		APPV: T. ELBIN 29AUG2011	PRODUCT SPEC		
	2 PLC	±			APPLICATION SPEC		
	3 PLC	±			MATERIAL		
	4 PLC	±			FINISH		
	ANGLES	±			WEIGHT		
				Customer Accessible Production Drawing		SCALE: 1:2 SHEET 4 OF 4 REV: K1	