

THIS DRAWING IS UNPUBLISHED. RELEASED FOR PUBLICATION  
 © COPYRIGHT - By - ALL RIGHTS RESERVED.

LOC	DIST	REVISIONS			
P	LTR	DESCRIPTION	DATE	DWN	APVD
GP	00	M	REVISED PER ECO-15-011825	14DEC2015	AP DG

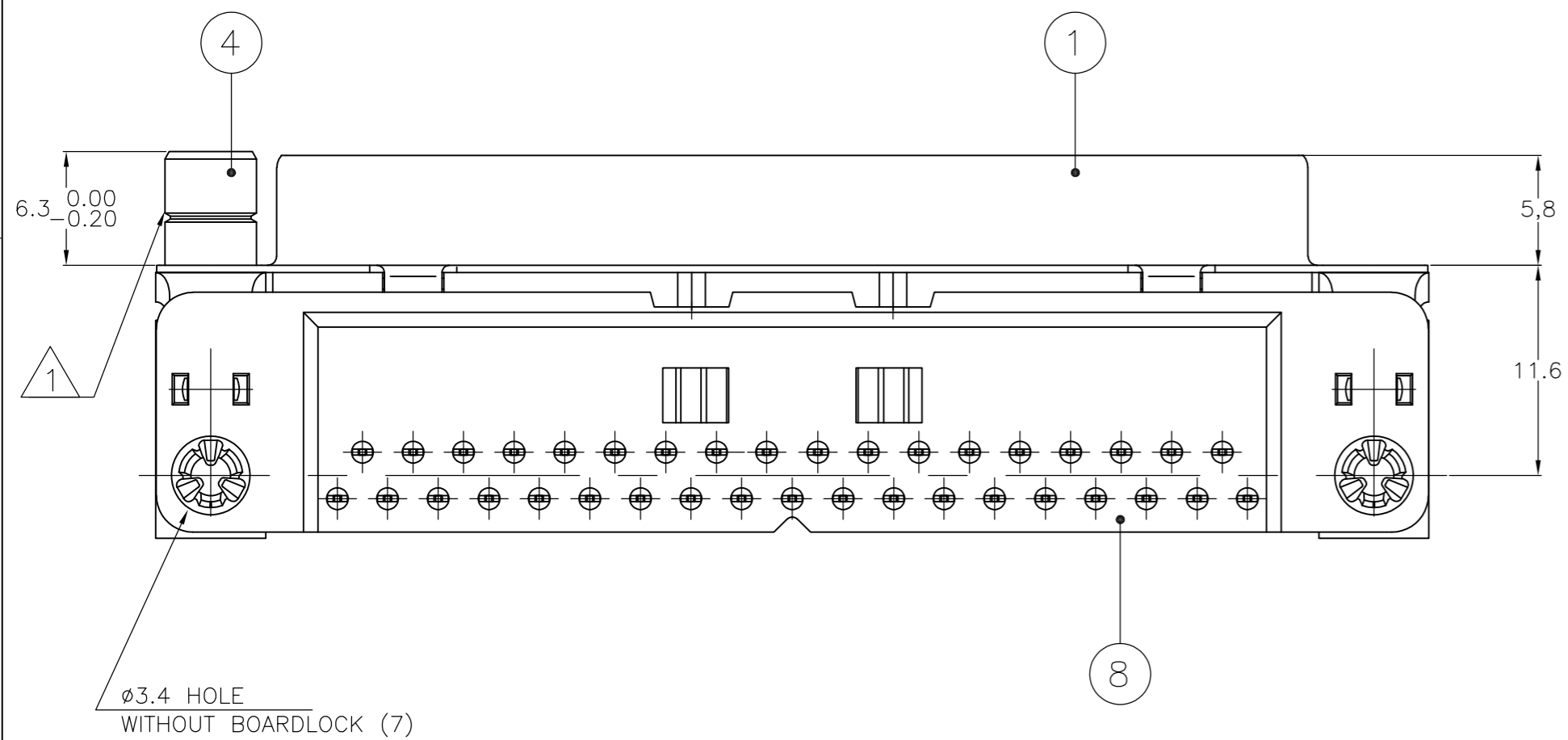
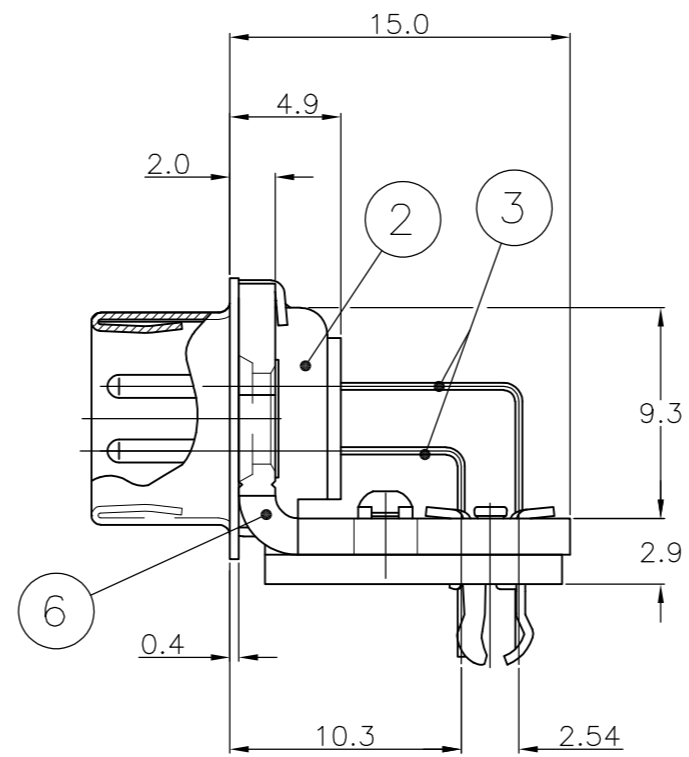
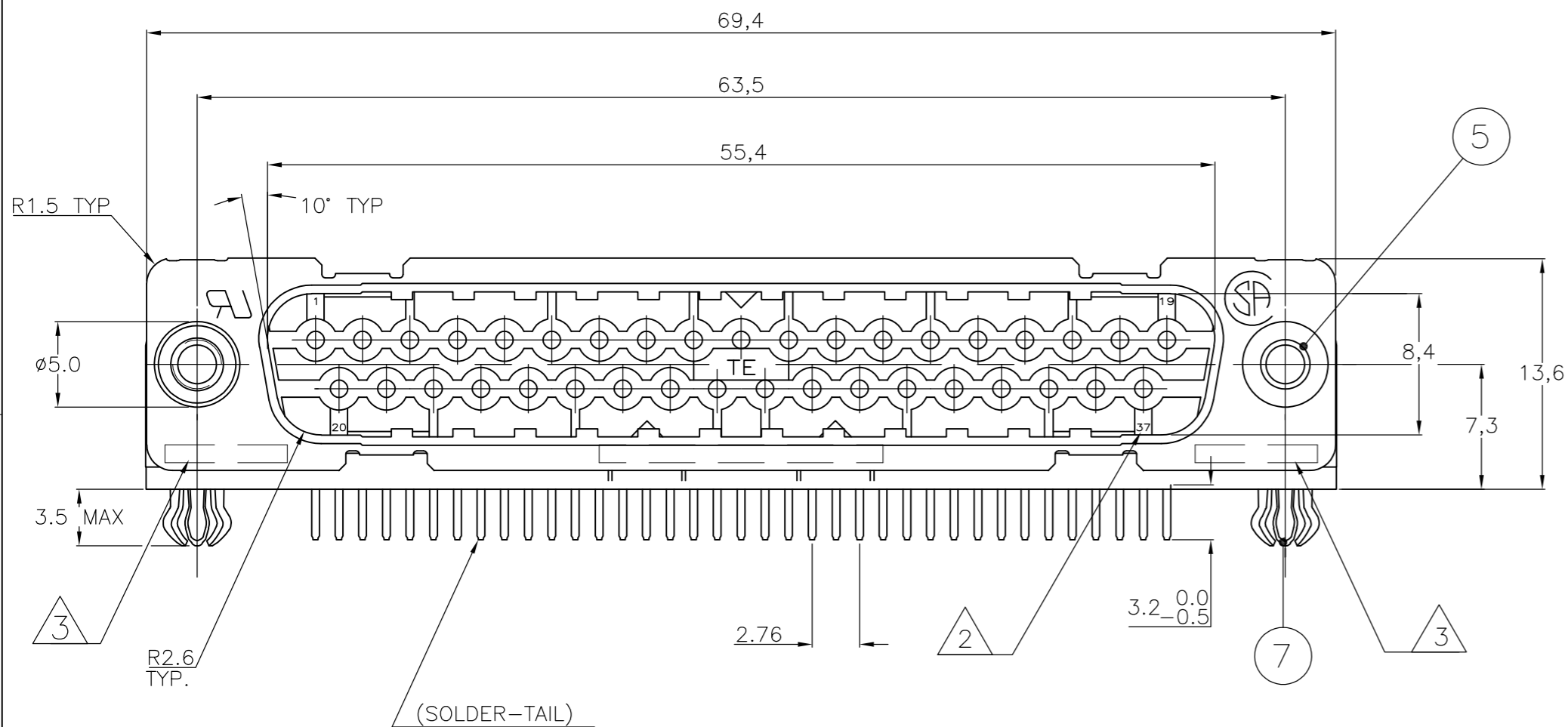

ACCESSORIES	ITEM NR.	DESCRIPTION OF ACCESSORY	2	2	2	2	2	2	2	2	2	2	2
	5	Ø3.1 INSERT	2										
	5	INSERT WITH INNER THREAD 4-40 UNC		2						2			
	5	INSERT WITH INNER THREAD M3			2						2		
	4	FEMALE SCREWLOCK WITH 4-40 UNC				2						2	
	4	FEMALE SCREWLOCK WITH M3					2						2
	7	BOARDLOCK	2	2	2	2	2	2					

1 GROOVE INDICATES VERSION WITH 4-40 UNC INNER THREAD; WITHOUT GROOVE INDICATES VERSION WITH M3 INNER THREAD.

2 CAVITY IDENTIFICATION AT FRONT SIDE ONLY.

3 PART NUMBER AND DATE CODE.

4 SHELL HAS 2x12 GROUNDING SPRINGS; PITCH IS 3.6.

5 AIR AND CREEPAGE DISTANCES ACCORDING TO DIN 41652.

6 CONTACT FINISH: GOLD FLASH OVER PALLADIUM-NICKEL PLATE OR GOLD PLATE ON THE MATING SURFACES, TIN PLATE ON THE SOLDER-TAILS, NICKEL UNDERPLATE ON THE ENTIRE CONTACT. MATING SURFACE FINISH MEETS PERFORMANCE LEVEL 2 PER DIN 41652.

RECOMMENDED P.C. BOARD HOLE-LAYOUT

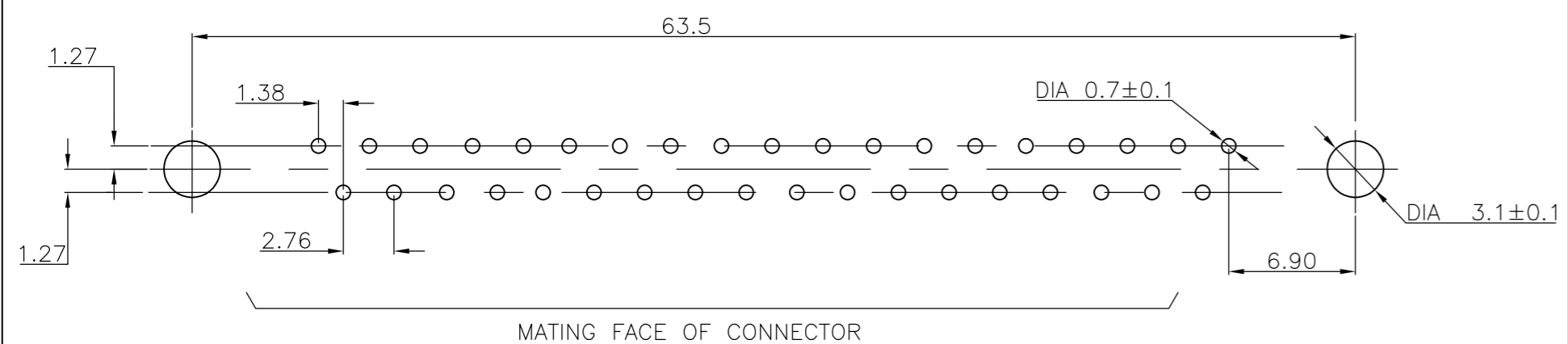

ITEM NO/MATERIAL :

- 1 SHELL : BRIGHT TIN PLATED STEEL
- 2 HOUSING : GLASS FILLED POLYESTER, COLOR : BLACK
- 3 CONTACTS : PHOSPHOR BRONZE (PLATING : SEE NOTES)
- 4 FEMALE SCREWLOCK : TIN PLATED STEEL (INNER THREAD 4-40 UNC OR M3)
- 5 INSERT : TIN PLATED STEEL (INNER THREAD 4-40 UNC OR M3 OR Ø3.1 THRU-HOLE)
- 6 BRACKET : TIN PLATED STEEL
- 7 BOARDLOCK : TIN PLATED PHOSPHOR BRONZE
- 8 SOLDER-TAIL ALIGNMENT PLATE : GLASS FILLED NYLON. COLOR : BLACK

THIS DRAWING IS A CONTROLLED DOCUMENT. DIMENSIONING AND TOLERANCING PER ASME Y14.5M-2009		DWN D. KESSLER 18JAN99		
DIMENSIONS: mm		CHK W. SOOMERS		
TOLERANCES UNLESS OTHERWISE SPECIFIED:		APVD -	NAME	
0 PLC ± -	1 PLC ± -	PRODUCT SPEC -	HD-20 SIZE 4	
2 PLC ± -	3 PLC ± -	APPLICATION SPEC -	RIGHT ANGLE PLUG HEADER; MARK II+	
4 PLC ± -	ANGLES ± -	WEIGHT -	SIZE A2	CAGE CODE 00779
MATERIAL -	FINISH -	CUSTOMER DRAWING	DRAWING NO C=338171	RESTRICTED TO -
			SCALE NTS	SHEET 1 OF 1