

LOC	DIST	REVISIONS					
AF	50	P	LTR	DESCRIPTION	DATE	DWN	APVD
		G		REVISED PER ECR-06-010423	13SEP06	HMR	KR

- 1 CONTINUOUS STRIP ON REELS WITH TERMINALS LOCATED ON 8.38±0.08 [.330±.003] CENTERS.
- 2 SLOT ACCEPTS 0.18-0.23mm [#33-#31] AWG COPPER MAGNET WIRE. TWO WIRES OF THE SAME SIZE MAX PER SLOT
- 3 IDENTIFICATION NUMBER 4 FOR THE MAGNET WIRE SLOT SIZE
- 4 0.25 [.010] MAX CARRIER CUT-OFF TABS
- 5 PRE-PRODUCTION - F.A.S.R. REQUIRED.

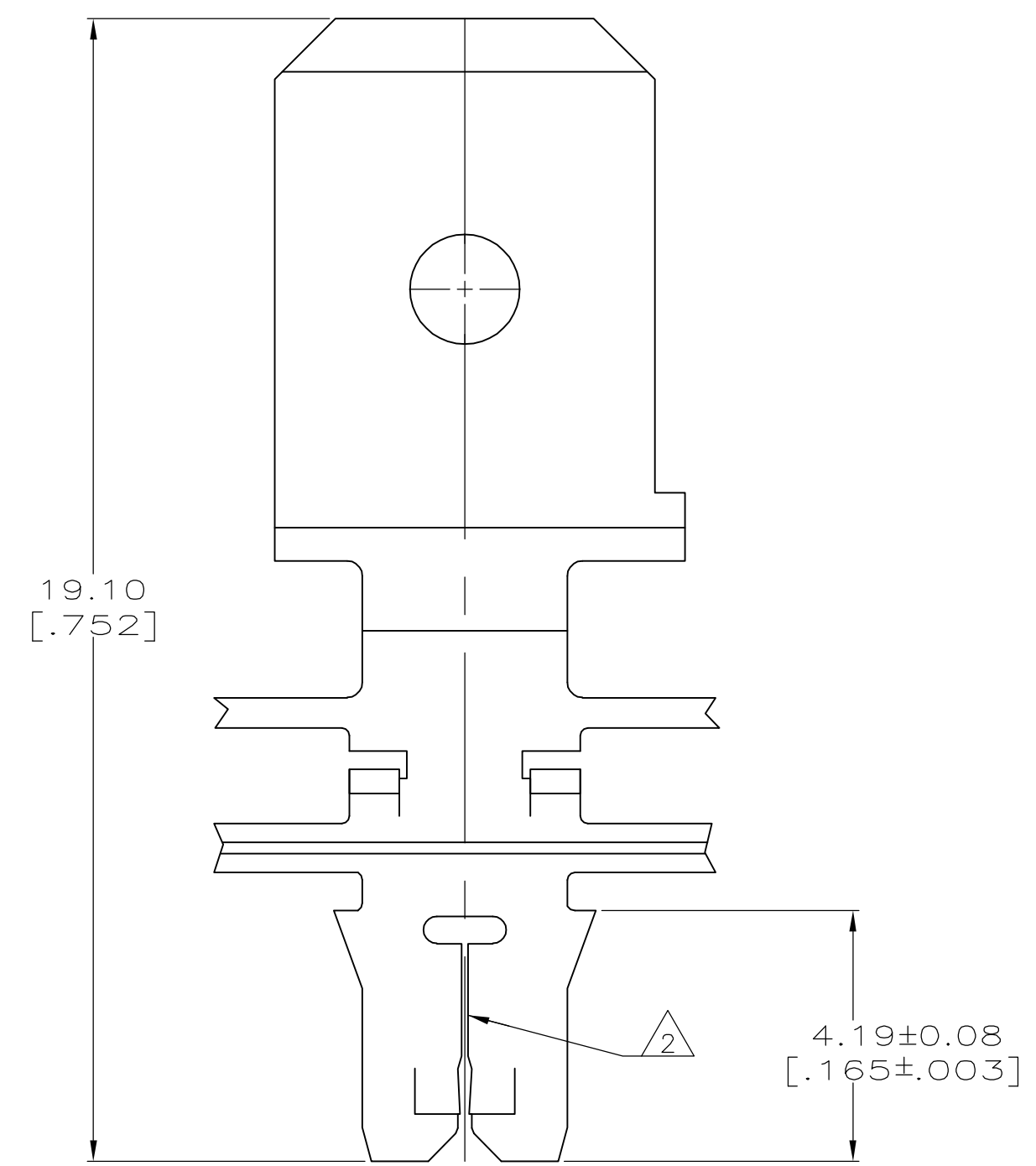
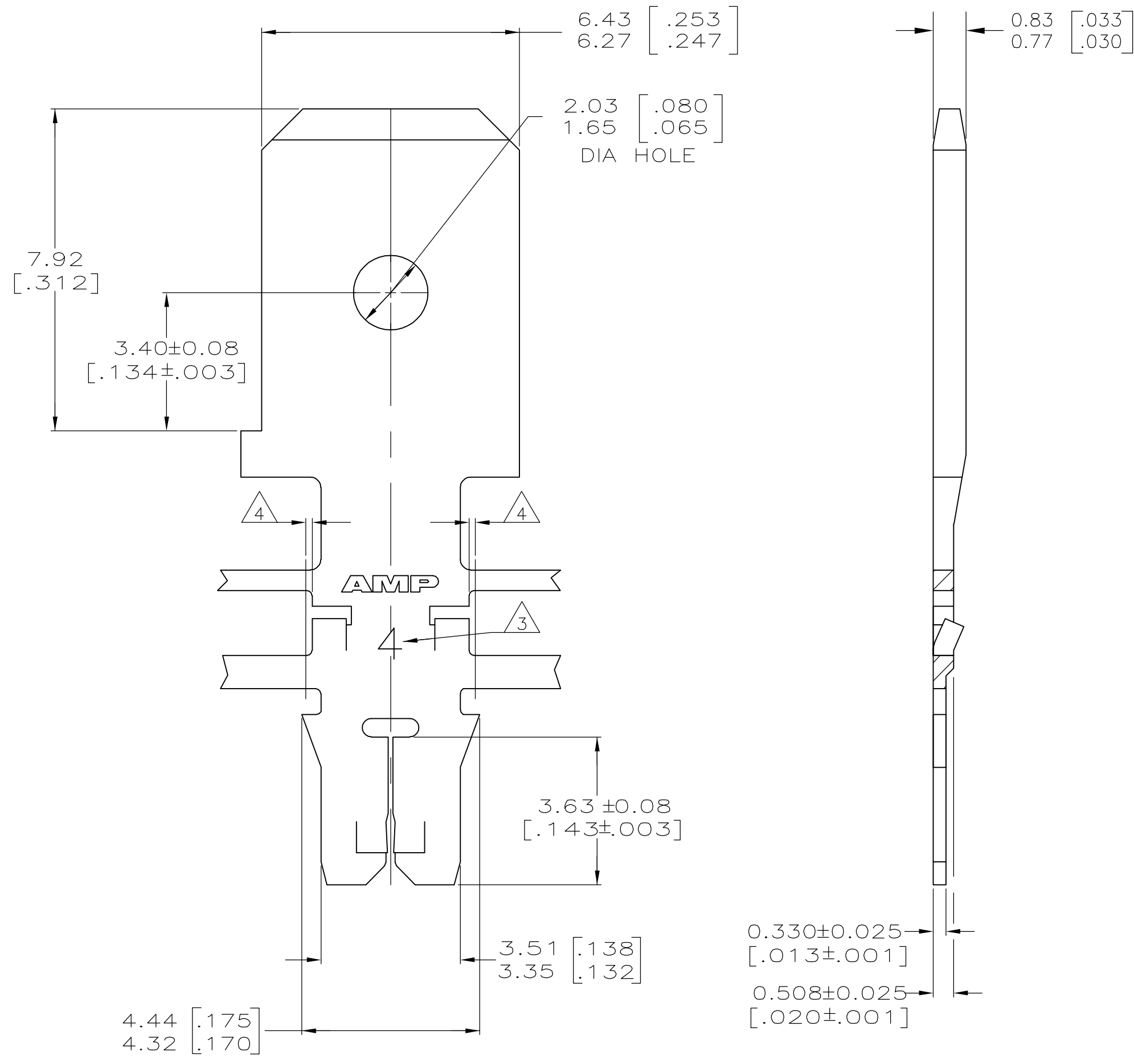

OBSOLETE	082 PRE-MILLED BRASS	5	63716-2
	4M PRE-MILLED BRASS		63716-1
MATERIAL		PART NUMBER	

THIS DRAWING IS A CONTROLLED DOCUMENT.		DWN	L.A.MAYER	9-27-93		Tyco Electronics Corporation	
DIMENSIONS: mm [INCHES]		CHK	M.S. FEHER	9-27-93		Harrisburg, PA 17105-3608	
TOLERANCES UNLESS OTHERWISE SPECIFIED:		APVD	A.HUNT III	9-27-93		NAME	
0 PLC ± -	1 PLC ± -	PRODUCT SPEC		108-1484		TAB, 6.35 [.250] FASTON™	
2 PLC ± 0.13 [.005]	3 PLC ± -	APPLICATION SPEC		114-2140		MAG-MATE™ Slim Line	
4 PLC ± -	ANGLES ± -	MATERIAL		SIZE	A2	CAGE CODE	00779
FINISH	0.002032 [.000080] MIN TIN PLATE	SEE TABLE		WEIGHT	-	DRAWING NO	G-63716
CUSTOMER DRAWING		SCALE		10:1	SHEET	1 of 1	REV
						G	