

REVISIONS				
P	LTR	DESCRIPTION	DATE	APVD
	H2	REVISED PER ECR-22-131479	18APR2022	LP DCS

AMP WIRE RANGE	Listed E13288	LR7189 Certified
22-16 AWG SOLID OR STRANDED	22-16 AWG SOLID OR STRANDED	22-16 AWG SOLID OR STRANDED

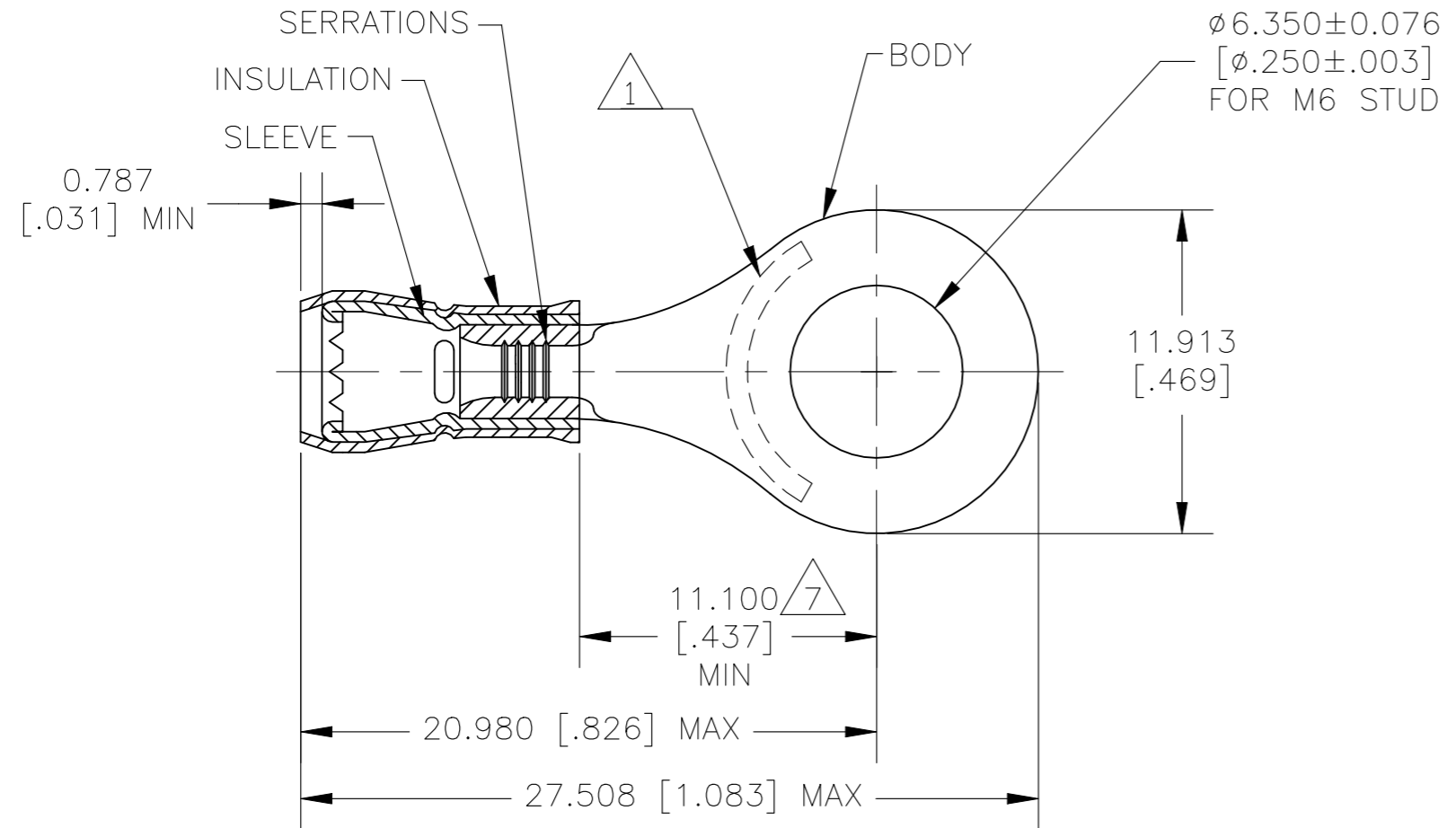

- 1 STAMP "AMP 22-18*" APPROX AS SHOWN, 22-16 TERMINALS ARE STAMPED 22-18 IN ACCORDANCE WITH MILITARY SPECIFICATION SAE AS7928, COMMERCIAL WIRE RANGE IS 22-16.
- 2 MATERIAL: BODY & SLEEVE- COPPER PER ASTM B152, ANNEALED. INSULATION - NYLON
- 3 FINISH: BODY & SLEEVE- 0.00254 [.000100] MIN TIN PLATE PER ASTM B545 INSULATION COLOR - RED
- 4 NOTE DELETED
- 5 WIRE INSULATION DIAMETER: Ø2.667[Ø.105] TO Ø3.556[Ø.140]
- 6 BODY MATERIAL THK: 0.787±0.051 [.031±.002]
- 7 DIMENSION APPLIES FROM EDGE OF WIRE BARREL TO CENTER OF STUD HOLE.
- 8 NOTE DELETED
- 9 NOTE DELETED
- 10 NOTE DELETED

1000	LOOSE PIECE	130046
QTY	PACKAGING TYPE	PART NO

AMP INCORPORATED CUSTOMER SERVICE SYSTEMS		MAX RECOMMENDED OPERATING TEMPERATURE: 105°C [221°F]	THIS DRAWING IS A CONTROLLED DOCUMENT.		DWN jr_ruth 28OCT09 CHK T MICHELUTTI 28OCT09 APVD T MICHELUTTI 28OCT09	TE Connectivity			
		VOLTAGE RATING: 300V MAX	DIMENSIONS: mm[INCHES]	TOLERANCES UNLESS OTHERWISE SPECIFIED: 0 PLC ± - 1 PLC ± - 2 PLC ± - 3 PLC ± 0.127[.005] 4 PLC ± - ANGLES ± -	PRODUCT SPEC UL 486A-B APPLICATION SPEC 114-2157				NAME TERMINAL, RING TONGUE, PIDG, WIRE SIZE: 22-16 AWG
FOR ADDITIONAL PRODUCT INFORMATION OR COPIES OF DRAWINGS AND TECHNICAL DOCUMENTS PRODUCT INFORMATION CENTER 1-800-522-6752	FOR APPLICATION TOOLING ASSISTANCE CENTER TOOLING INFORMATION 1-800-722-1111	CIRCULAR MIL AREA: 0.26mm² - 1.65mm² [509-3260] SOLID OR STRANDED	MATERIAL	FINISH	PRODUCT SPEC UL 486A-B APPLICATION SPEC 114-2157	SIZE A3	CAGE CODE 00779	DRAWING NO C-130046	RESTRICTED TO -
FOR ORDER ENTRY 1-800-526-5142			CUSTOMER DRAWING		WEIGHT -	SCALE 4:1	SHEET 1 OF 1	REV H2	