

# NCV7424

## Four Channel LIN Transceiver

NCV7424 is a four channel physical layer device using the Local Interconnect Network (LIN) protocol. It allows interfacing of four independent LIN physical buses and the LIN protocol controllers. The device is compliant to LIN 2.x Protocol Specification package and the SAE J2602 standard.

The NCV7424 LIN device is a member of the in-vehicle networking (IVN) transceiver family. The device is a monolithic solution incorporating 4 times the NCV7321-1 transceiver.

### Features

- TSSOP-16 Package. Pin-out Compatible with One Single LIN NCV7321 Transceiver (Pin Numbers 4 to 7, and 10 to 13)
- Compliant with LIN2.x, Backwards Compatible to Version 1.3 and J2602
- Transmission Rate 1 kbps to 20 kbps
- Indefinite Short-Circuit Protection on LIN towards Supply and Ground
- Bus Pins Protected Against Transients in an Automotive Environment
- Thermal Shutdown
- System ESD on LIN Pin Exceeding 10 kV, No Need for External ESD Protections
- Load Dump Protection (45 V)
- Integrated Slope Control Resulting into Excellent EME Performance also without any Capacitor on LIN Pin
- Excellent EMI Performance
- Remote Wake-up via LIN Bus on all Four Channels
- 3.3 V and 5 V Compatible Digital Inputs

### Quality

- NCV Prefix for Automotive and Other Applications Requiring Unique Site and Control Change Requirements; AEC-Q100 Qualified and PPAP Capable
- These Devices are Pb-Free, Halogen Free/BFR Free and are RoHS Compliant



ON Semiconductor®

[www.onsemi.com](http://www.onsemi.com)

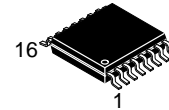

TSSOP-16  
CASE 948F

### PACKAGE PICTURE

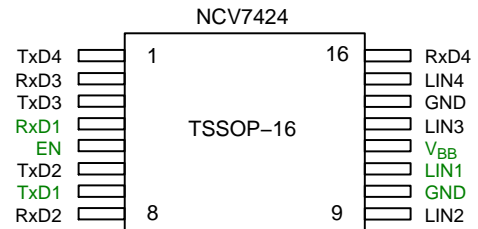

### MARKING DIAGRAM

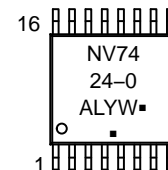

NV7424-0 = Specific Device Code  
A = Assembly Location  
L = Wafer Lot  
Y = Year  
W = Work Week  
▪ = Pb-Free Package

(Note: Microdot may be in either location)

### ORDERING INFORMATION

See detailed ordering, marking and shipping information in the package dimensions section on page 11 of this data sheet.

# NCV7424

## BLOCK DIAGRAM

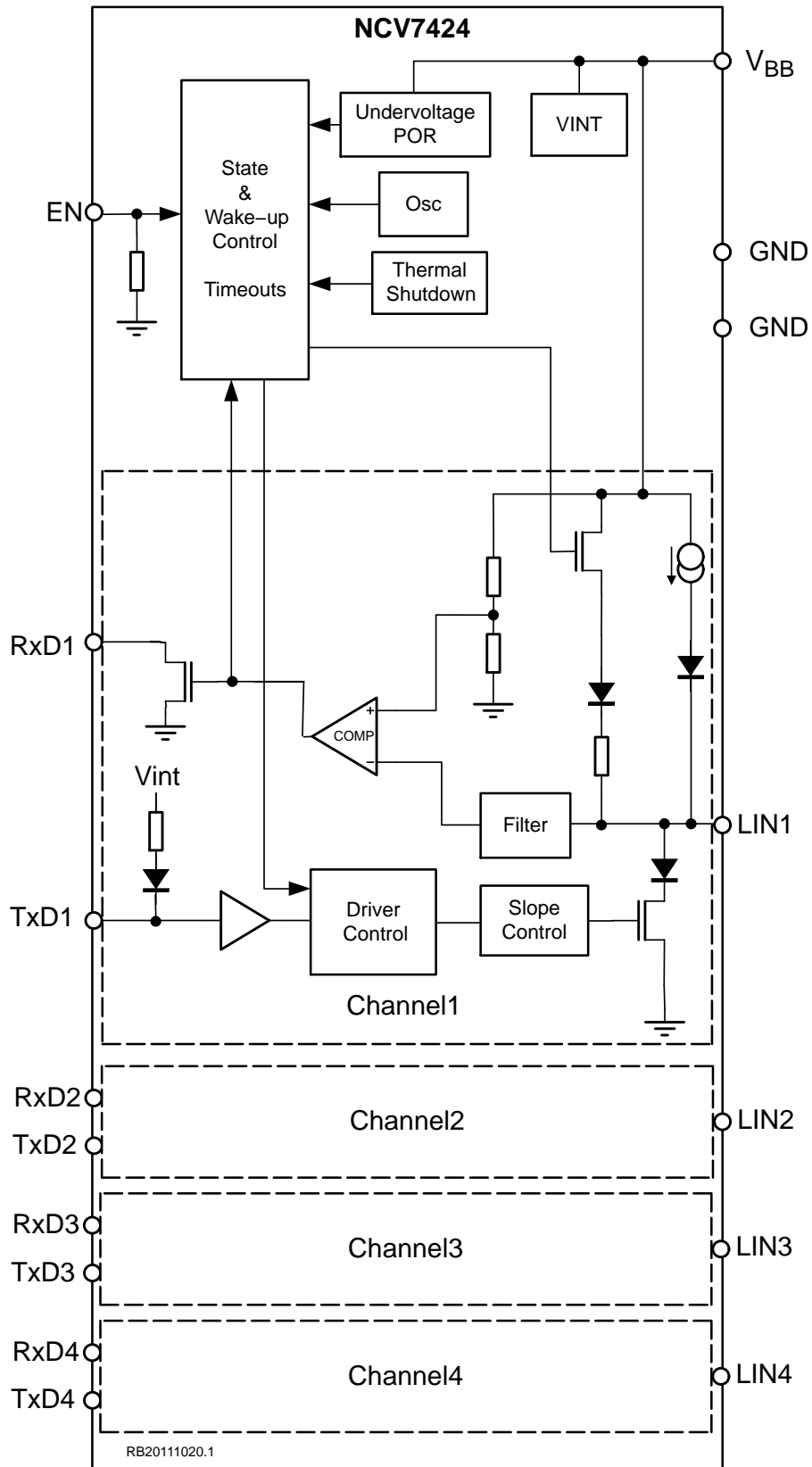

Figure 1. Block Diagram

# NCV7424

**Table 1. KEY TECHNICAL CHARACTERISTICS AND OPERATING RANGES**

Symbol	Parameter	Min	Typ	Max	Unit
V <sub>BB</sub>	Nominal Battery Operating Voltage (Note 1)	5	12	27	V
	Load Dump Protection			45	
I <sub>BB_SLP</sub>	Supply Current in Sleep Mode, V <sub>BB</sub> = 12 V, T <sub>J</sub> < 85°C V <sub>LINx</sub> = V <sub>BB</sub>		10	30	μA
V <sub>LIN</sub>	LIN Bus Voltage	-45		45	V
V <sub>Dig_IO</sub>	Operating DC Voltage on Digital IO Pins (EN, RxD1-4, TxD1-4)	0		5.5	V
T <sub>J</sub>	Junction Thermal Shutdown Temperature	150	165	185	°C
T <sub>amb</sub>	Operating Ambient Temperature	-40		125	°C
V <sub>ESD</sub>	Electrostatic Discharge Voltage (all pins) Human Body Model (Note 2) Conform to EIA-JESD22-A114-B	-4		4	kV
	Electrostatic Discharge Voltage (LIN) System Human Body Model (Note 3) Conform to EIC 61000-4-2	-10		10	kV

- Below 5 V on V<sub>BB</sub> in normal mode, the bus will either stay recessive or comply with the voltage level specifications and transition time specifications as required by SAE J2602. It is ensured by the battery monitoring circuit. Above 27 V on V<sub>BB</sub>, LIN communication is operational (LIN pin toggling) but parameters cannot be guaranteed. For higher battery voltage operation above 27 V, LIN pull-up resistor must be selected large enough to avoid clamping of LIN pin by voltage drop over external pull-up resistor and LIN pin min current limitation.
- Equivalent to discharging a 100 pF capacitor through a 1.5 kΩ resistor.
- Equivalent to discharging a 150 pF capacitor through a 330 Ω resistor. System HBM levels are verified by an external test-house.

**Table 2. PIN FUNCTION DESCRIPTION**

Pin	Name	Description
1	TxD4	Transmit Data Input, Low for Dominant State; Pull-up to internal supply guaranteed above pin input threshold
2	RxD3	Receive Data Output; Low in Dominant State
3	TxD3	Transmit Data Input, Low for Dominant State; Pull-up to internal supply guaranteed above pin input threshold
4	RxD1	Receive Data Output; Low in Dominant State
5	EN	Enable Input, Transceiver in Normal Operation Mode when High, Pull-down Resistor to GND
6	TxD2	Transmit Data Input, Low for Dominant State; Pull-up to internal supply guaranteed above pin input threshold
7	TxD1	Transmit Data Input, Low for Dominant State; Pull-up to internal supply guaranteed above pin input threshold
8	RxD2	Receive Data Output; Low in Dominant State
9	LIN2	LIN Bus Output/Input
10	GND	Ground
11	LIN1	LIN Bus Output/Input
12	V <sub>BB</sub>	Battery Supply Input
13	LIN3	LIN Bus Output/Input
14	GND	Ground
15	LIN4	LIN Bus Output/Input
16	RxD4	Receive Data Output; Low in Dominant State

# NCV7424

## TYPICAL APPLICATION

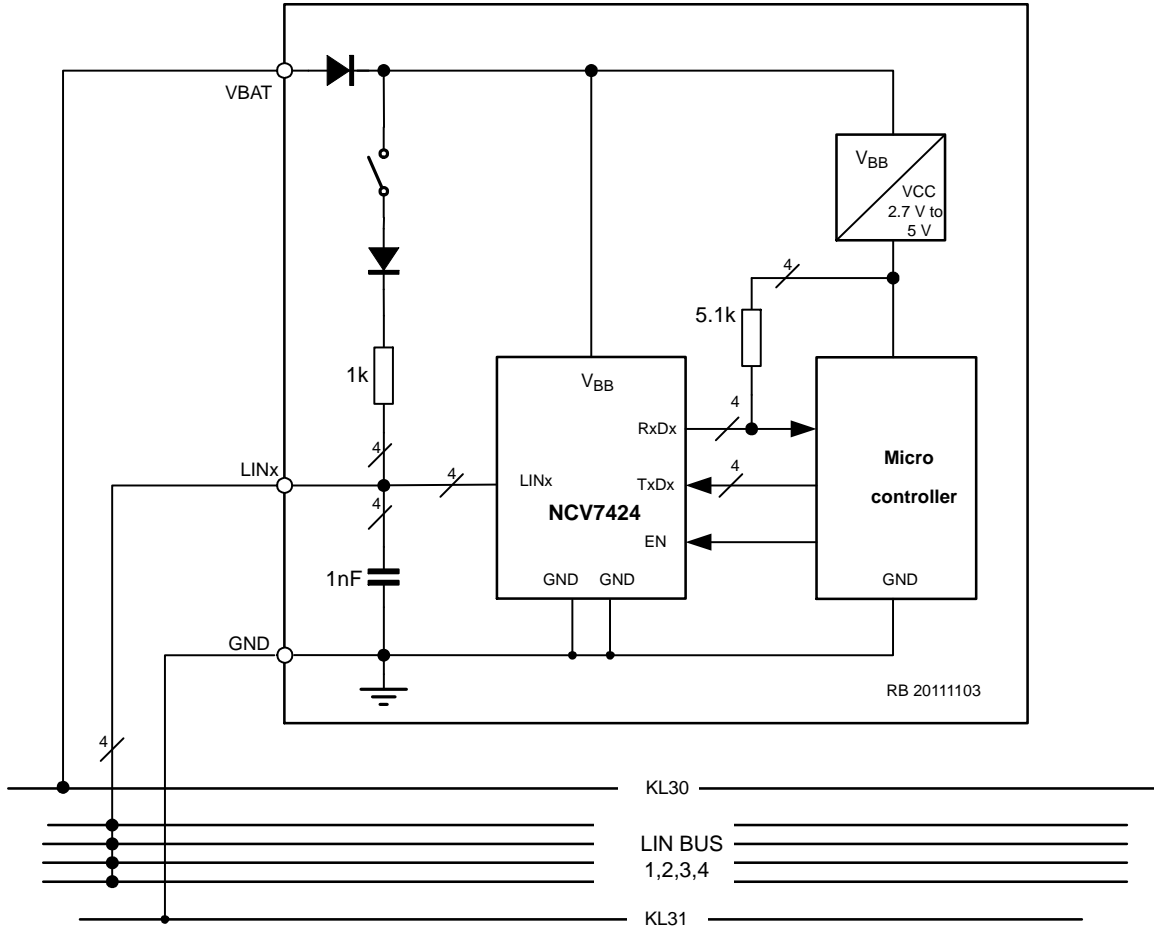

Figure 2. Application Diagram, Four LIN Master Nodes

Table 3. ABSOLUTE MAXIMUM RATINGS

Symbol	Parameter	Min	Typ	Max	Unit
$V_{BB}$	Voltage on Pin $V_{BB}$	-0.3		45	V
$V_{LINx}$	LINx Bus Voltage (LIN1-4)	-45		45	V
$V_{Dig\_IO}$	DC Input Voltage on Pins (EN, RxD1-4, TxD1-4)	-0.3		7	V
$T_J$	Maximum Junction Temperature	-40		150	°C
$V_{ESD}$	HBM (All Pins) (Note 4) Conform to EIA-JESD22-A114-B	-4		4	kV
	CDM (All Pins) According to ESD STM 5.3.1-1999	-750		750	V
	HBM (LINx and $V_{BB}$ ) (Note 4)	-8		8	kV
	System HBM (LINx and $V_{BB}$ ) (Note 5) Conform to EIC 61000-4-2	-10		10	kV

Stresses exceeding those listed in the Maximum Ratings table may damage the device. If any of these limits are exceeded, device functionality should not be assumed, damage may occur and reliability may be affected.

4. Equivalent to discharging a 100 pF capacitor through a 1.5 kΩ resistor.

5. Equivalent to discharging a 150 pF capacitor through a 330 Ω resistor. System HBM levels are verified by an external test-house.

Table 4. THERMAL CHARACTERISTICS

Symbol	Parameter	Conditions	Value	Unit
R <sub>θJA_1</sub>	Thermal Resistance Junction-to-Air, JESD51-3 1S0P PCB	Free air	128	K/W
R <sub>θJA_2</sub>	Thermal Resistance Junction-to-Air, JESD51-7 2S2P PCB	Free air	72	K/W

FUNCTIONAL DESCRIPTION

Overall Functional Description

LIN is a serial communication protocol that efficiently supports the control of mechatronic nodes in distributed automotive applications. The domain is class-A multiplex buses with a single master node and a set of slave nodes.

The NCV7424 contains four independent LIN transmitters, LIN receivers plus common battery monitoring, power-on-reset (POR) circuits and thermal shutdown (TSD). The used LIN transmitter is optimized for the maximum specified transmission speed of 20 kbps with

excellent EMC performance due to reduced slew rate of the LIN outputs.

The junction temperature is monitored via a thermal shutdown circuit that switches the LIN transmitters off when temperature exceeds the TSD trigger level.

The NCV7424 has four operating states (unpowered mode, standby mode, normal mode and sleep mode) that are determined by the supply voltage V<sub>BB</sub>, input signals EN and activity on the LIN bus. The operating states and principal transitions between them are depicted in Figure 3.

OPERATING STATES

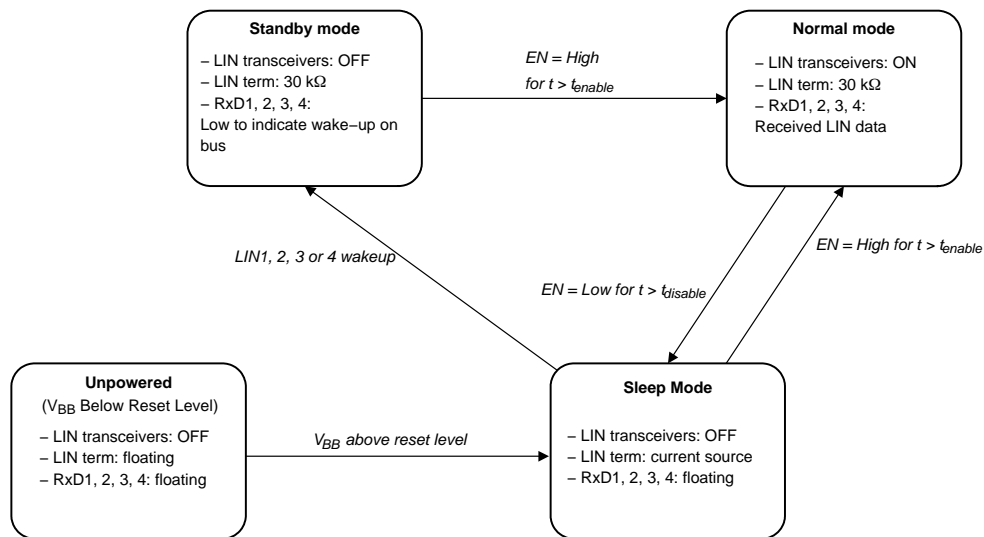

Figure 3. State Diagram

Unpowered Mode

As long as V<sub>BB</sub> remains below its power-on-reset level, the chip is kept in a safe unpowered state. LIN transmitters are inactive, LINx pins are left floating. Pins RxDx remain floating.

The unpowered state will be entered from any other state when V<sub>BB</sub> falls below its power-on-reset level.

Standby Mode

Standby mode is a low-power mode, where the LIN transceivers remain inactive. A 30 kΩ resistor in series with a reverse-protection diode is internally connected between individual LIN pins and pin V<sub>BB</sub>. Standby mode is entered after a wake-up event is recognized while the chip was in the

sleep mode, the RxD1,2,3 or 4 pin is pulled low depending on which of the respective pins LIN1,2,3 or 4 the valid LIN wake-up occurred. While staying in standby mode, wake-up signaling by RxDx pins on each LIN channel is fully functional. This is also in case if wake event(s) started in sleep mode but actual transition from sleep to standby was caused by preceding wake-up event on other LIN channel.

Normal Mode

In normal mode, the full functionality of the LIN transceivers is available. Data are sent to the LINx bus according to the state of TxDx inputs and RxDx pins reflect the logical symbol received on the LINx bus – high-impedant for recessive and Low level for dominant.

A 30 kΩ resistor in series with a reverse-protection diode is internally connected between LIN and V<sub>BB</sub> pins.

To avoid that, due to a failure of the application (e.g. software error, a short to ground, etc.), the LIN bus is permanently driven dominant and thus blocking all subsequent communication, the signal on each TxDx pin passes through an independent timer per LIN channel, which releases the bus in case TxDx remains

Low for longer than t<sub>TxD\_timeout</sub>. The transmission can continue once the TxDx returns to High logical level. This is independent on each channel, means permanent dominant on one channel is not blocking the other channels from communication.

In case the junction temperature increases above the thermal shutdown threshold, e.g. due to a short of the LIN wiring to the battery and high ambient temperature, all four transmitters are disabled and LIN buses are kept in recessive state independently of TxDx inputs. RxTx pins are kept Low during thermal shutdown.

Once the junction temperature decreases below the thermal shutdown release level, the transmission is enabled again. RxTx pins are released from asserted thermal shutdown low level immediately when chip is below thermal shutdown threshold.

As required by SAE J2602, the transceiver behaves safely below its operating range – it either continues to transmit correctly (according to its specification) or remains silent (transmits a recessive state regardless of the TxTx signal). A battery monitoring circuit in NCV7424 deactivates the transmitter in normal mode if the V<sub>BB</sub> level drops below MONL\_VBB. Transmission is enabled again when V<sub>BB</sub> reaches MONH\_VBB. The internal logic remains in normal mode and the reception from the LIN line is still possible even if the battery monitor disables the transmission. Although the specifications of the monitoring and power-on-reset levels are overlapping, it is ensured by the implementation that the monitoring level never falls below the power-on-reset level.

Normal mode can be entered from either standby or sleep mode when EN Pin is High for longer than t<sub>enable</sub>. When the transition is made from standby mode, RxTx is put high-impedant immediately after EN becomes High (before the expiration of t<sub>enable</sub> filtering time). Transmission on each LINx channel is only possible for particular TxTx pin starting from High to Low level (if TxTx pin is Low when entering Normal mode, transmission is not enabled).

**Sleep Mode**

Sleep mode provides extremely low current consumption. The LIN transceiver is inactive and the battery consumption is minimized. Only a weak pull-up current source is internally connected between LIN and V<sub>BB</sub> pins, in order to minimize current consumption even in case of LIN short to GND.

Sleep mode can be entered:

- After the voltage level at V<sub>BB</sub> pin rises above its power-on-reset level. RxTx pins are set high-impedant after start-up
- From normal mode by assigning a Low logical level to pin EN for longer than t<sub>disable</sub>. The sleep mode can be entered even if a permanent short occurs on the LINx Pin.

If a wake-up event occurs during the transition between normal and sleep mode (during the t<sub>disable</sub> filtering time), it will be regarded as a valid wake-up and the chip will enter standby mode with the appropriate setting of pins RxTx.

**LIN Wake-up**

Remote (or LIN) wake-up can be recognized on all LINx pins on NCV7424 when LINx bus is externally driven dominant for longer than t<sub>LIN\_wake</sub> and a rising edge on LIN occurs afterwards – see Figure 4. Wake-up events can be exclusively detected in sleep mode or during the transition from normal mode to sleep mode. Due to timing tolerances, valid wake-up events beginning shortly before normal-to-sleep mode transition can be also sometimes regarded as valid wake-ups.

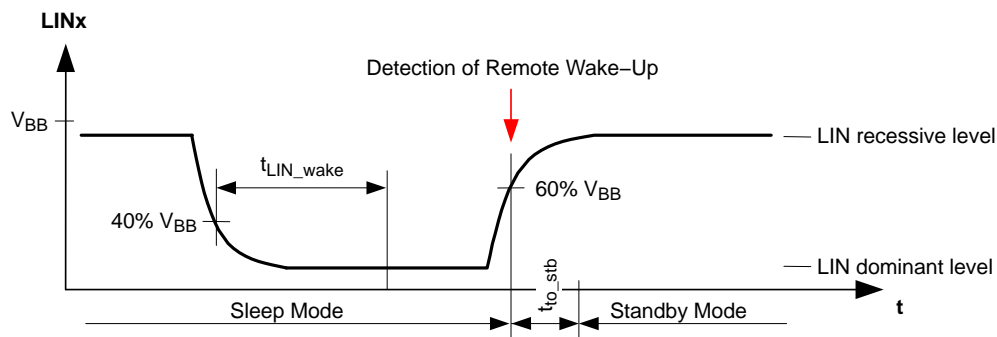

Figure 4. LIN Bus Wake-up Detection

ELECTRICAL CHARACTERISTICS

Definitions

All voltages are referenced to GND (Pins 10, 14. These pins are electrically connected inside of the package). Positive currents flow into the IC.

**Table 5. DC CHARACTERISTICS** ( $V_{BB} = 5\text{ V to }27\text{ V}$ ;  $T_J = -40^\circ\text{C to }+150^\circ\text{C}$ ;  $R_{L(LIN-V_{BB})} = 500\ \Omega$ , unless otherwise specified. Typical values are given at  $V(V_{BB}) = 12\text{ V}$  and  $T_J = 25^\circ\text{C}$ , unless otherwise specified.)

Symbol	Parameter	Conditions	Min	Typ	Max	Unit
--------	-----------	------------	-----	-----	-----	------

**CURRENT CONSUMPTION**

$I_{BB\_ON\_rec}$	$V_{BB}$ Consumption	Normal Mode; LIN Recessive $V_{LINx} = V_{BB}$		2.3	4.7	mA
$I_{BB\_ON\_dom}$	$V_{BB}$ Consumption	Normal Mode; LIN Dominant TxDx = Low		16.5	28	mA
$I_{BB\_STB}$	$V_{BB}$ Consumption	Standby Mode $V_{LINx} = V_{BB}$		0.22	0.45	mA
$I_{BB\_SLP}$	$V_{BB}$ Consumption	Sleep Mode $V_{LINx} = V_{BB}$		11	35	$\mu\text{A}$
$I_{BB\_SLP\_18V}$	$V_{BB}$ Consumption	Sleep Mode, $V_{BB} < 18\text{ V}$ $V_{LINx} = V_{BB}$		10	33	$\mu\text{A}$
$I_{BB\_SLP\_12V}$	$V_{BB}$ Consumption	Sleep Mode, $V_{BB} = 12\text{ V}$ , $T_J < 85^\circ\text{C}$ $V_{LINx} = V_{BB}$		9	30	$\mu\text{A}$

**POR AND  $V_{BB}$  MONITOR**

PORH_ $V_{BB}$	Power-on Reset High Level on $V_{BB}$	$V_{BB}$ Rising	2	3.3	4.5	V
PORL_ $V_{BB}$	Power-on Reset Low Level on $V_{BB}$	$V_{BB}$ Falling	1.7	2.9	4	V
MONH_ $V_{BB}$	Battery Monitoring High Level	$V_{BB}$ Rising		4.1	4.5	V
MONL_ $V_{BB}$	Battery Monitoring Low Level	$V_{BB}$ Falling	3	4		V

**LIN TRANSMITTERS**

$V_{LINx\_dom\_LoSup}$	LINx Dominant Output Voltage	TxDx = Low; $V_{BB} = 7.3\text{ V}$		1	1.2	V
$V_{LINx\_dom\_HiSup}$	LINx Dominant Output Voltage	TxDx = Low; $V_{BB} = 18\text{ V}$		1.4	2.0	V
$V_{LINx\_REC}$	LIN Recessive Output Voltage	TxDx = High; $I_{LIN} = 10\ \mu\text{A}$ (Note 6)	$V_{BB} - 1.5$		$V_{BB}$	V
$I_{LINx\_lim}$	Short Circuit Current Limitation	$V_{LINx} = V_{BB} = 18\text{ V}$ ; TxDx = Low	70	140	200	mA
$R_{LINx\_slave}$	Internal Pull-up Resistance		20	33	47	$\text{k}\Omega$

**LIN RECEIVERS**

$V_{LINx\_bus\_dom}$	Bus Voltage for Dominant State				0.4	$V_{BB}$
$V_{LINx\_bus\_rec}$	Bus Voltage for Recessive State		0.6			$V_{BB}$
$V_{LINx\_rec\_dom}$	Receiver Threshold	LIN Bus Recessive – Dominant	0.4	0.45	0.6	$V_{BB}$
$V_{LINx\_rec\_rec}$	Receiver Threshold	LIN Bus Dominant – Recessive	0.4	0.55	0.6	$V_{BB}$

6. The voltage drop in Normal mode between LIN and  $V_{BB}$  pin is the sum of the diode drop and the drop at serial pull-up resistor. The drop at the switch is negligible. See Figure 1.

# NCV7424

**Table 5. DC CHARACTERISTICS** ( $V_{BB} = 5\text{ V to }27\text{ V}$ ;  $T_J = -40^\circ\text{C to }+150^\circ\text{C}$ ;  $R_{L(LIN-V_{BB})} = 500\ \Omega$ , unless otherwise specified. Typical values are given at  $V(V_{BB}) = 12\text{ V}$  and  $T_J = 25^\circ\text{C}$ , unless otherwise specified.)

Symbol	Parameter	Conditions	Min	Typ	Max	Unit
<b>LIN RECEIVERS</b>						
V <sub>LINx_rec_cnt</sub>	Receiver Centre Voltage	$(V_{LINx\_rec\_dom} + V_{LINx\_rec\_rec}) / 2$	0.475	0.5	0.525	V <sub>BB</sub>
V <sub>LINx_rec_hys</sub>	Receiver Hysteresis	$(V_{LINx\_rec\_rec} - V_{LINx\_rec\_dom})$	0.05	0.1	0.175	V <sub>BB</sub>
I <sub>LINx_off_dom</sub>	LIN Output Current, Bus externally driven to dominant state	Normal Mode, Driver Off; V <sub>BB</sub> = 12 V; TxDx = High; V <sub>LINx</sub> = 0 V	-1	-0.37	-0.2	mA
I <sub>LINx_off_dom_slp</sub>	LIN Output Current, Bus externally driven to dominant state	Sleep Mode, Driver Off; V <sub>BB</sub> = 12 V; TxDx = High; V <sub>LINx</sub> = 0 V	-20	-8	-2	μA
I <sub>LINx_off_rec</sub>	LIN Output Current, Bus in Recessive State	Driver Off; V <sub>BB</sub> < 18 V; V <sub>BB</sub> < V <sub>LINx</sub> < 18 V			2	μA
I <sub>LINx_no_GND</sub>	Communication not Affected	V <sub>BB</sub> = GND = 12 V; 0 < V <sub>LINx</sub> < 18 V	-1		1	mA
I <sub>LINx_no_V<sub>BB</sub></sub>	LIN Bus Remains Operational	V <sub>BB</sub> = GND = 0 V; 0 < V <sub>LINx</sub> < 18 V		0	5	μA
C <sub>LINx</sub>	Capacitance on LINx pin	Not tested in production, guaranteed by design		20	30	pF
<b>PIN EN</b>						
V <sub>il_EN</sub>	Low Level Input Voltage		-0.3		0.8	V
V <sub>ih_EN</sub>	High Level Input Voltage		2.0		5.5	V
R <sub>pd_EN</sub>	Pull-down Resistance to Ground		150	350	650	kΩ
<b>PIN RxDx</b>						
I <sub>ol_RxDx</sub>	Low Level Output Current	V <sub>RxD</sub> = 0.4 V, Normal Mode, V <sub>LINx</sub> = 0 V	1.5	4.3		mA
I <sub>oh_RxDx</sub>	High Level Output Current	V <sub>RxD</sub> = 5 V, Normal Mode, V <sub>LINx</sub> = V <sub>BB</sub>	-5	0	5	μA
<b>PIN TxDx</b>						
V <sub>il_TxDx</sub>	Low Level Input Voltage		-0.3		0.8	V
V <sub>ih_TxDx</sub>	High Level Input Voltage		2.0		5.5	V
R <sub>pd_TxDx</sub>	Pull-up on TxDx Pins		60	100	150	kΩ
<b>THERMAL SHUTDOWN</b>						
T <sub>JSD</sub>	Thermal Shutdown Junction Temperature	Temperature Rising	150	165	185	°C
T <sub>JSD_HYST</sub>	Thermal Shutdown Hysteresis			5		°C

6. The voltage drop in Normal mode between LIN and V<sub>BB</sub> pin is the sum of the diode drop and the drop at serial pull-up resistor. The drop at the switch is negligible. See Figure 1.



# NCV7424

**Table 6. AC CHARACTERISTICS** ( $V_{BB} = 5\text{ V to }27\text{ V}$ ;  $T_J = -40^\circ\text{C to }+150^\circ\text{C}$ ;  $R_{L(LIN-V_{BB})} = 500\ \Omega$ , unless otherwise specified. For the transmitter parameters, the following bus loads are considered:  $L1 = 1\text{ k}\Omega / 1\text{ nF}$ ;  $L2 = 660\ \Omega / 6.8\text{ nF}$ ;  $L3 = 500\ \Omega / 10\text{ nF}$ )

Symbol	Parameter	Conditions	Min	Typ	Max	Unit
<b>LIN TRANSMITTER</b>						
D1	Duty Cycle 1 = $t_{BUS\_REC(min)} / (2 \times t_{BIT})$	$TH_{REC(max)} = 0.744 \times V_{BB}$ $TH_{DOM(max)} = 0.581 \times V_{BB}$ $t_{BIT} = 50\ \mu\text{s}$ $V(V_{BB}) = 7\text{ V to }18\text{ V}$	0.396		0.5	
D2	Duty Cycle 2 = $t_{BUS\_REC(max)} / (2 \times t_{BIT})$	$TH_{REC(min)} = 0.422 \times V_{BB}$ $TH_{DOM(min)} = 0.284 \times V_{BB}$ $t_{BIT} = 50\ \mu\text{s}$ $V(V_{BB}) = 7.6\text{ V to }18\text{ V}$	0.5		0.581	
D3	Duty Cycle 3 = $t_{BUS\_REC(min)} / (2 \times t_{BIT})$	$TH_{REC(max)} = 0.778 \times V_{BB}$ $TH_{DOM(max)} = 0.616 \times V_{BB}$ $t_{BIT} = 96\ \mu\text{s}$ $V(V_{BB}) = 7\text{ V to }18\text{ V}$	0.417		0.5	
D4	Duty Cycle 4 = $t_{BUS\_REC(max)} / (2 \times t_{BIT})$	$TH_{REC(min)} = 0.389 \times V_{BB}$ $TH_{DOM(min)} = 0.251 \times V_{BB}$ $t_{BIT} = 96\ \mu\text{s}$ $V(V_{BB}) = 7.6\text{ V to }18\text{ V}$	0.5		0.590	
D1e	Duty Cycle 1 = $t_{BUS\_REC(min)} / (2 \times t_{BIT})$	$TH_{REC(max)} = 0.744 \times V_{BB}$ $TH_{DOM(max)} = 0.581 \times V_{BB}$ $t_{BIT} = 50\ \mu\text{s}$ $V(V_{BB}) = 5\text{ V to }40\text{ V}$ , (Notes 7 and 8)	0.39		0.5	
D2e	Duty Cycle 2 = $t_{BUS\_REC(max)} / (2 \times t_{BIT})$	$TH_{REC(min)} = 0.422 \times V_{BB}$ $TH_{DOM(min)} = 0.284 \times V_{BB}$ $t_{BIT} = 50\ \mu\text{s}$ $V(V_{BB}) = 5\text{ V to }40\text{ V}$ , (Notes 7 and 8)	0.5		0.59	
D3e	Duty Cycle 3 = $t_{BUS\_REC(min)} / (2 \times t_{BIT})$	$TH_{REC(max)} = 0.778 \times V_{BB}$ $TH_{DOM(max)} = 0.616 \times V_{BB}$ $t_{BIT} = 96\ \mu\text{s}$ $V(V_{BB}) = 5\text{ V to }40\text{ V}$ , (Notes 7 and 8)	0.41		0.5	
D4e	Duty Cycle 4 = $t_{BUS\_REC(max)} / (2 \times t_{BIT})$	$TH_{REC(min)} = 0.389 \times V_{BB}$ $TH_{DOM(min)} = 0.251 \times V_{BB}$ $t_{BIT} = 96\ \mu\text{s}$ $V(V_{BB}) = 5\text{ V to }40\text{ V}$ , (Notes 7 and 8)	0.5		0.6	
$t_{tx\_prop\_down\_x}$	Propagation Delay of TxDx to LINx. TxD High to Low		1.3	4.2	10	$\mu\text{s}$
$t_{tx\_prop\_up\_x}$	Propagation Delay of TxDx to LINx. TxD Low to High		1.3	4.6	10	$\mu\text{s}$
$t_{tx\_sym\_x}$	Propagation Delay Symmetry	$t_{tx\_prop\_down\_x} - t_{tx\_prop\_up\_x}$	-2.5	-0.4	2.5	$\mu\text{s}$
$t_{fall}$	LINx Falling Edge	Normal Mode; $V_{BB} = 12\text{ V}$		9	22.5	$\mu\text{s}$
$t_{rise}$	LINx Rising Edge	Normal Mode; $V_{BB} = 12\text{ V}$		10	22.5	$\mu\text{s}$
$t_{sym}$	LINx Slope Symmetry	Normal Mode; $V_{BB} = 12\text{ V}$	-4	0	4	$\mu\text{s}$
<b>LIN RECEIVERS</b>						
$t_{rec\_prop\_down\_x}$	Propagation Delay of LINx to RxDx Receiver Falling Edge		0.1	1.6	6	$\mu\text{s}$
$t_{rec\_prop\_up\_x}$	Propagation Delay of LINx to RxDx Receiver Rising Edge		0.1	1.35	6	$\mu\text{s}$
$t_{rec\_sym\_x}$	Propagation Delay Symmetry	$t_{rec\_prop\_down\_x} - t_{rec\_prop\_up\_x}$	-2	0.25	2	$\mu\text{s}$

7. The external pull-up resistor for duty cycles on  $V(V_{BB}) = 40\text{ V}$  is  $1\text{ k}\Omega$

8. Not tested in production Extended battery range (5 V; 40 V) is tested on limited sample base only

# NCV7424

**Table 6. AC CHARACTERISTICS** ( $V_{BB} = 5\text{ V to }27\text{ V}$ ;  $T_J = -40^\circ\text{C to }+150^\circ\text{C}$ ;  $R_{L(LIN-V_{BB})} = 500\ \Omega$ , unless otherwise specified. For the transmitter parameters, the following bus loads are considered:  $L1 = 1\text{ k}\Omega / 1\text{ nF}$ ;  $L2 = 660\ \Omega / 6.8\text{ nF}$ ;  $L3 = 500\ \Omega / 10\text{ nF}$ )

Symbol	Parameter	Conditions	Min	Typ	Max	Unit
<b>MODE TRANSITIONS AND TIMEOUTS</b>						
$t_{LINx\_wake}$	Duration of LINx Dominant for Detection of Wake-up via LINx bus	Sleep Mode	30	90	150	$\mu\text{s}$
$t_{to\_stb}$	Delay from LIN Bus Dominant to Recessive Edge to Entering of Standby Mode after Valid LIN Wake-up	See Figure 4	2	2.8	18.5	$\mu\text{s}$
$t_{enable}$	Duration of High Level on EN Pin for Transition to Normal Mode		2	18	47	$\mu\text{s}$
$t_{disable}$	Duration of Low Level on EN Pin for Transition to Sleep Mode		2	7.5	18.5	$\mu\text{s}$
$t_{TxD\_timeout}$	TxD Dominant Timeout	Normal Mode, TxD = Low, Guarantees Baudrate as Low as 1 kbps	15	28	50	ms

7. The external pull-up resistor for duty cycles on  $V(V_{BB}) = 40\text{ V}$  is  $1\text{ k}\Omega$
8. Not tested in production Extended battery range ( $5\text{ V}$ ;  $40\text{ V}$ ) is tested on limited sample base only

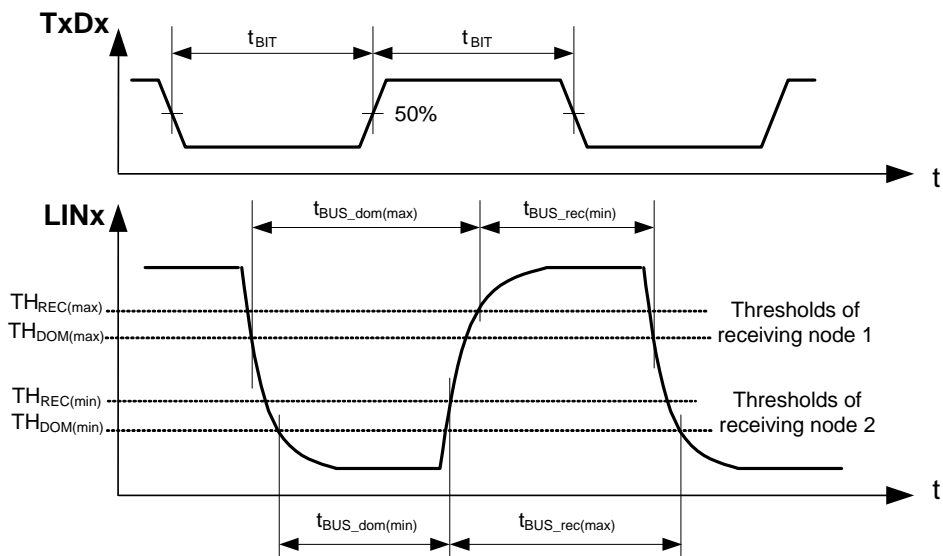

**Figure 5. LINx Bus Transmitter Duty Cycle**

# NCV7424

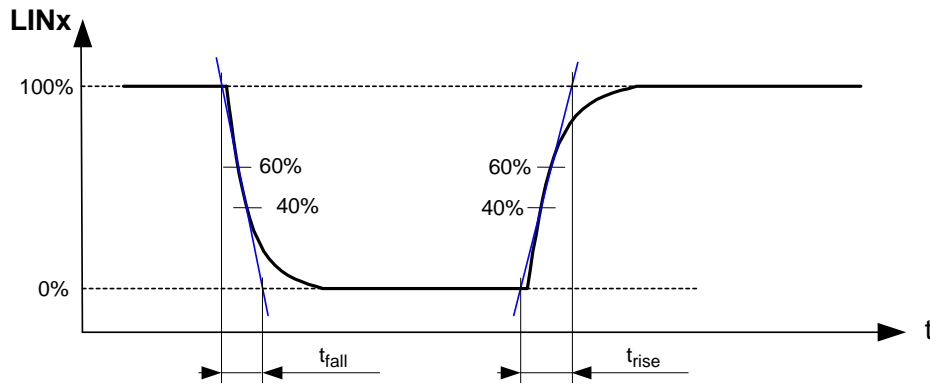

Figure 6. LINx Bus Transmitter Rising and Falling Times

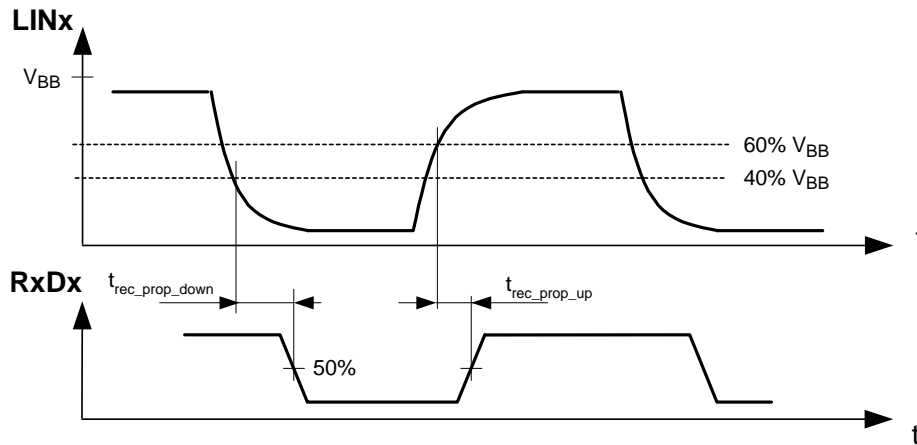

Figure 7. LINx Bus Receiver Timing

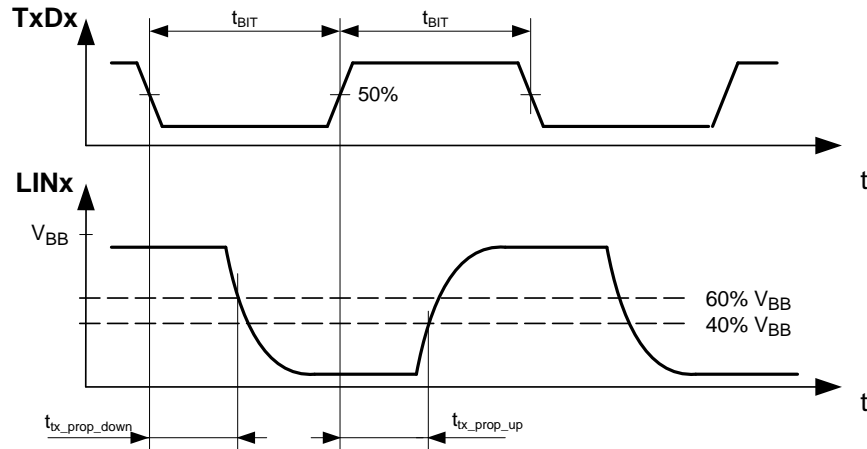

Figure 8. LINx Transmitter Timing

## ORDERING INFORMATION

Part Number	Description	Temperature Range	Package	Shipping†
NCV7424DB0R2G	Quad LIN Transceiver	-40°C to +125°C	TSSOP-16 (Pb-Free)	2500 / Tape & Reel

†For information on tape and reel specifications, including part orientation and tape sizes, please refer to our Tape and Reel Packaging Specifications Brochure, BRD8011/D.

# MECHANICAL CASE OUTLINE

## PACKAGE DIMENSIONS

ON Semiconductor®

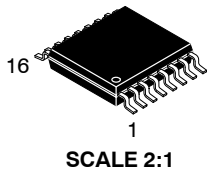

TSSOP-16  
CASE 948F-01  
ISSUE B

DATE 19 OCT 2006

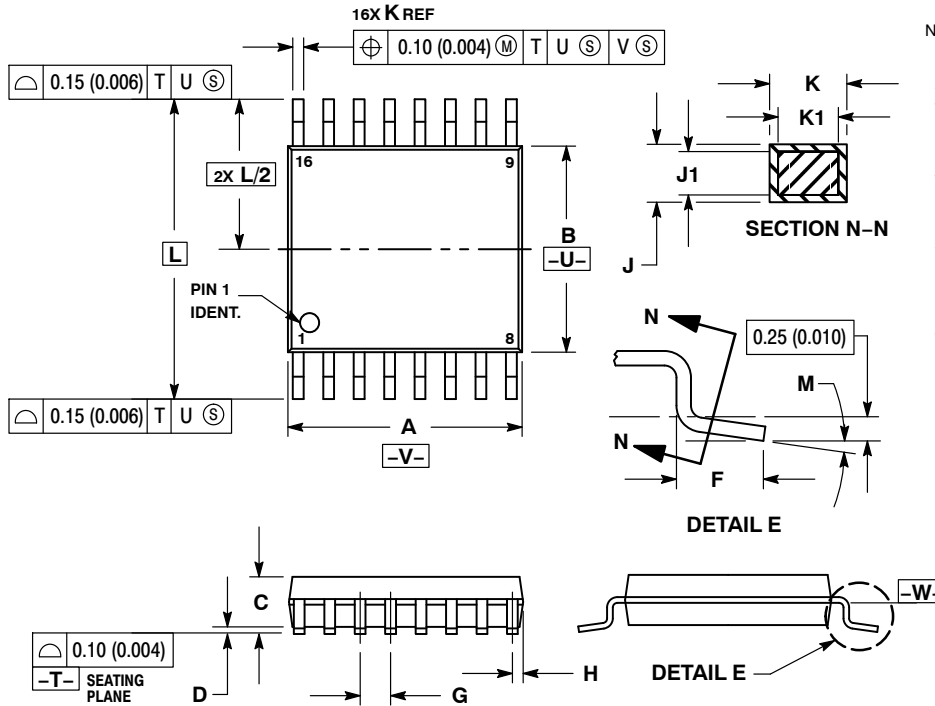

NOTES:

1. DIMENSIONING AND TOLERANCING PER ANSI Y14.5M, 1982.
2. CONTROLLING DIMENSION: MILLIMETER.
3. DIMENSION A DOES NOT INCLUDE MOLD FLASH. PROTRUSIONS OR GATE BURRS. MOLD FLASH OR GATE BURRS SHALL NOT EXCEED 0.15 (0.006) PER SIDE.
4. DIMENSION B DOES NOT INCLUDE INTERLEAD FLASH OR PROTRUSION. INTERLEAD FLASH OR PROTRUSION SHALL NOT EXCEED 0.25 (0.010) PER SIDE.
5. DIMENSION K DOES NOT INCLUDE DAMBAR PROTRUSION. ALLOWABLE DAMBAR PROTRUSION SHALL BE 0.08 (0.003) TOTAL IN EXCESS OF THE K DIMENSION AT MAXIMUM MATERIAL CONDITION.
6. TERMINAL NUMBERS ARE SHOWN FOR REFERENCE ONLY.
7. DIMENSION A AND B ARE TO BE DETERMINED AT DATUM PLANE -W-.

DIM	MILLIMETERS		INCHES	
	MIN	MAX	MIN	MAX
A	4.90	5.10	0.193	0.200
B	4.30	4.50	0.169	0.177
C	---	1.20	---	0.047
D	0.05	0.15	0.002	0.006
F	0.50	0.75	0.020	0.030
G	0.65 BSC		0.026 BSC	
H	0.18	0.28	0.007	0.011
J	0.09	0.20	0.004	0.008
J1	0.09	0.16	0.004	0.006
K	0.19	0.30	0.007	0.012
K1	0.19	0.25	0.007	0.010
L	6.40 BSC		0.252 BSC	
M	0°	8°	0°	8°

SOLDERING FOOTPRINT

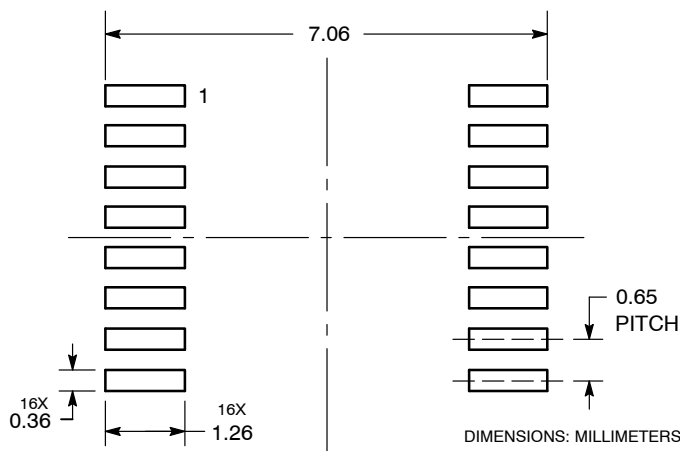

GENERIC MARKING DIAGRAM\*

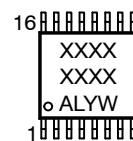

- XXXX = Specific Device Code
- A = Assembly Location
- L = Wafer Lot
- Y = Year
- W = Work Week
- G or ■ = Pb-Free Package

\*This information is generic. Please refer to device data sheet for actual part marking. Pb-Free indicator, "G" or microdot "■", may or may not be present.

DOCUMENT NUMBER:	98ASH70247A	Electronic versions are uncontrolled except when accessed directly from the Document Repository. Printed versions are uncontrolled except when stamped "CONTROLLED COPY" in red.
DESCRIPTION:	TSSOP-16	PAGE 1 OF 1

ON Semiconductor and ON are trademarks of Semiconductor Components Industries, LLC dba ON Semiconductor or its subsidiaries in the United States and/or other countries. ON Semiconductor reserves the right to make changes without further notice to any products herein. ON Semiconductor makes no warranty, representation or guarantee regarding the suitability of its products for any particular purpose, nor does ON Semiconductor assume any liability arising out of the application or use of any product or circuit, and specifically disclaims any and all liability, including without limitation special, consequential or incidental damages. ON Semiconductor does not convey any license under its patent rights nor the rights of others.

**onsemi**, **Onsemi**, and other names, marks, and brands are registered and/or common law trademarks of Semiconductor Components Industries, LLC dba "**onsemi**" or its affiliates and/or subsidiaries in the United States and/or other countries. **onsemi** owns the rights to a number of patents, trademarks, copyrights, trade secrets, and other intellectual property. A listing of **onsemi**'s product/patent coverage may be accessed at [www.onsemi.com/site/pdf/Patent-Marking.pdf](http://www.onsemi.com/site/pdf/Patent-Marking.pdf). **onsemi** reserves the right to make changes at any time to any products or information herein, without notice. The information herein is provided "as-is" and **onsemi** makes no warranty, representation or guarantee regarding the accuracy of the information, product features, availability, functionality, or suitability of its products for any particular purpose, nor does **onsemi** assume any liability arising out of the application or use of any product or circuit, and specifically disclaims any and all liability, including without limitation special, consequential or incidental damages. Buyer is responsible for its products and applications using **onsemi** products, including compliance with all laws, regulations and safety requirements or standards, regardless of any support or applications information provided by **onsemi**. "Typical" parameters which may be provided in **onsemi** data sheets and/or specifications can and do vary in different applications and actual performance may vary over time. All operating parameters, including "Typicals" must be validated for each customer application by customer's technical experts. **onsemi** does not convey any license under any of its intellectual property rights nor the rights of others. **onsemi** products are not designed, intended, or authorized for use as a critical component in life support systems or any FDA Class 3 medical devices or medical devices with a same or similar classification in a foreign jurisdiction or any devices intended for implantation in the human body. Should Buyer purchase or use **onsemi** products for any such unintended or unauthorized application, Buyer shall indemnify and hold **onsemi** and its officers, employees, subsidiaries, affiliates, and distributors harmless against all claims, costs, damages, and expenses, and reasonable attorney fees arising out of, directly or indirectly, any claim of personal injury or death associated with such unintended or unauthorized use, even if such claim alleges that **onsemi** was negligent regarding the design or manufacture of the part. **onsemi** is an Equal Opportunity/Affirmative Action Employer. This literature is subject to all applicable copyright laws and is not for resale in any manner.

## ADDITIONAL INFORMATION

### TECHNICAL PUBLICATIONS:

Technical Library: [www.onsemi.com/design/resources/technical-documentation](http://www.onsemi.com/design/resources/technical-documentation)  
onsemi Website: [www.onsemi.com](http://www.onsemi.com)

### ONLINE SUPPORT: [www.onsemi.com/support](http://www.onsemi.com/support)

For additional information, please contact your local Sales Representative at [www.onsemi.com/support/sales](http://www.onsemi.com/support/sales)