

AFBR-59F3Z

Compact 650 nm Transceiver for 1 Gbps Data communication
MLCC (Multilevel Coset Coded) over POF (Polymer Optical Fiber)



Data Sheet



Description

The Avago Technologies' AFBR-59F3Z transceiver provides system designers with the ability to support serial communication to data rates of one Gigabit over 2.2 mm jacketed standard Polymer Optical Fiber (POF).

The innovative bare fiber locking mechanism of the transceiver allows connection of POF cable with a simple insert-and-lock system; no connectors are required. This enables very fast installation and maintenance. This very compact designed Laser Class 1 product is UL listed, lead free and compliant with RoHS. The form factor is similar to the well known RJ-45 connector.

Transmitter

The transmitter contains a 650 nm LED, which is driven by a fully integrated driver IC. The LED driver operates at 3.3 V. The IC is a linear integrated LED driver with differential input signals. It converts the input voltage linear in an output current for the LED. The driver needs an active Power-Enable signal for active current output. With a Low signal on the PowerEnable pin, the driver is set to power-saving state. LED and IC are packaged in an optical subassembly.

The optical subassembly couples the optical output power over a optic lens efficiently into the POF fiber.

Receiver

The receiver device utilizes an integrated fiber optical receiver offering an integrated PIN photodiode together with the necessary amplifiers, which provide direct conversion of light to differential analog output signal.

Receiver circuitry provides an analog receive power monitor output proportional to the amount of optical light at the receiver.

The integrated receiver is packaged in an optical subassembly. This optical subassembly couples the optical power efficiently from POF fiber to the receiving PIN. The integrated IC operates at 3.3V.

The receiver can be set into a power-saving state by externally forcing the monitoring pin to a voltage above a threshold.

Features

- Easy bare fiber termination solution for 2.2 mm jacketed standard POF
- EMI/EMC robust
- Link lengths 50 m for 1 Gbps transmission with 1 mm core diameter POF (attenuation smaller than 0.19 dB/m and NA = 0.5)
- Operating temperature range 0 °C to 70 °C
- 3.3 V power supply operation
- Integrated optics to efficiently focus light for fiber coupling
- Analog receive power monitor (MON)

Applications

- Home/Office Networking
- Factory automation
- Industrial vision system

Package

The transceiver package contains the two optical subassemblies, which are mounted in the housing for bare fiber connection.

The metal shield on the bare fiber clamp transceiver provides excellent immunity to EMI/EMC.

Pin description and recommended PCB footprint

AFBR-597F3Z has ten active signal pins (including supply voltage and ground pins), two EMI shield solder posts, two additional ground pins and two mounting posts, which exit at the bottom of the housing.

The EMI shield and the additional ground pins (11,12,13 & 14) are isolated from the internal circuit of the transceiver and are to be connected to equipment chassis ground.

The mounting posts are to provide additional mechanical strength to hold the transceiver module on the application board.

Figure 1 shows the top view of the PCB footprint and Pin-out diagram.

Pin Descriptions

Pin No.	Name	Symbol	Pin No.	Name	Symbol
1	Data Input (Negative)	TDN	8	Imon/Rx_En	IMON/ Rx_EN
2	Data Input (Positive)	TDP	9	Data Output (Negative)	RDN
3	Ground Tx	GND	10	Data Output (Positive)	RDP
4	Supply Voltage Tx	Vdd	11	Chassis GND	
5	Tx_Enable	Tx_En	12	Chassis GND	
6	Supply Voltage Rx	Vdd	13	Chassis GND	
7	Ground Rx	GND	14	Chassis GND	

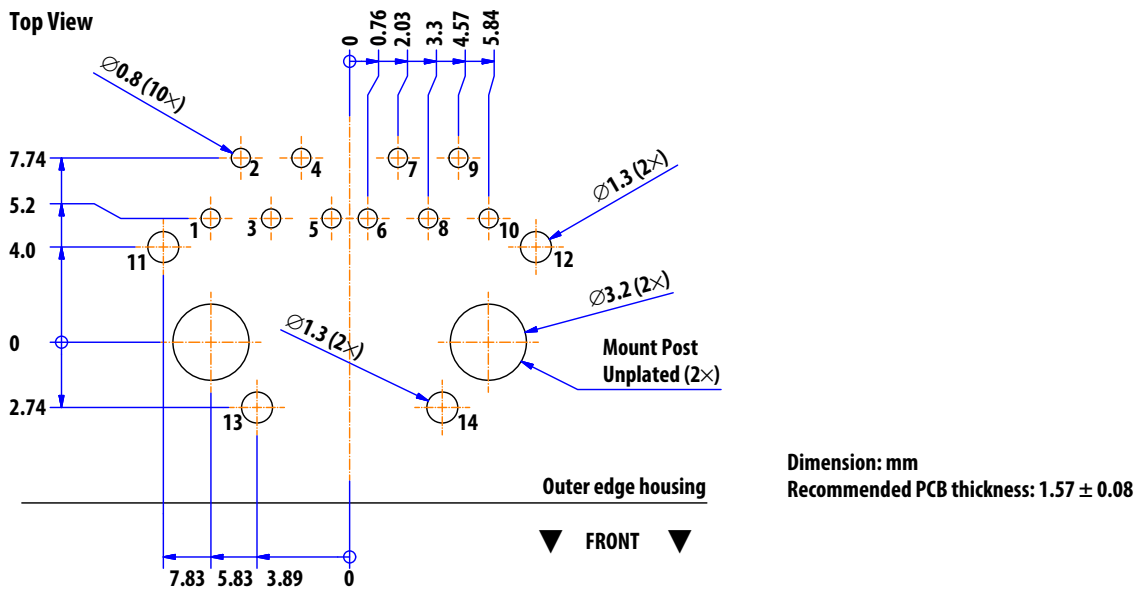

Figure 1. PCB footprint and Pin-out diagram

Recommended compliance table

Feature	Test Method	Performance
Electrostatic discharge (ESD) to the electrical Pins	JESD22-A114	Withstands up to 2 kV HBM applied between the electrical pins.
Eye safety	EN 60825-1:52007	Laser Class 1 product (LED radiation only).

Absolute Maximum Ratings

Stresses in excess of the absolute maximum ratings can cause catastrophic damage to the device. Limits apply to each parameter in isolation, all other parameters having values within the recommended operation conditions. It should not be assumed that limiting values of more than one parameter can be applied to the products at the same time. Exposure to the absolute maximum ratings for extended periods can adversely affect device reliability.

Parameter	Symbol	Min.	Max.	Units
Supply Voltage	$V_{dd\ Max}$	-0.5	4.5	V
Storage Temperature	T_{STG}	-40	85	°C
Lead Soldering Temperature ^[1]	T_{sold}		260	°C
Lead Soldering Time ^[1]	t_{sold}		10	s
Electrostatic Voltage Capability ^[2]	ESD		2.0	kV
Installation temperature ^[3]	T_I	0	50	°C

Notes:

1. The transceiver is Pb-free wave solderable. According to JEDEC J-STD-020D, the moisture sensitivity classification is MSL2a.
2. ESD Capability for all Pins HBM (human body model) according JESD22-A114B.
3. Temperature range over which fibers can be connected or disconnected to or from the bare fiber clamp.

Recommended Operating Conditions

Parameter	Symbol	Min.	Typ.	Max.	Units
Operating temperature	T_A	0	25	70	°C
DC Supply Voltage	V_{DD}	3.14	3.30	3.47	V

All the data in this specification refers to the operating conditions above and over lifetime, unless otherwise stated.

Mechanical Characteristics

Parameter	Min.	Typ.	Max.	Units	Temp. [°C]
Fiber/Cable Retention Force ^[5]		30		N	25
	15		50	N	0...70
Clamp opening force		20		N	25
	10		30	N	0...50 ^[4]
Clamp closing force		13		N	25
	5		20	N	0...50 ^[4]

Notes:

4. Temperature range over which fibers can be connected or disconnected to or from the bare fiber clamp.
5. Measured with Avago's AFBR-HUDxxxZ (2.2mm duplex-fiber, PE-jacket, without connector) with 100mm/ min traction speed.

Transmitter Electrical Characteristics

Parameter	Symbol	Min.	Typ.	Max.	Units
Current Consumption	I_{dd}		47	55	mA
Current Consumption – disabled	$I_{dd, Dis}$	0.4	0.6	0.8	mA
Symbol Rate	S_R			312.5	MSps
Input Impedance to GND	$Z_{IN, SE}$		64		Ω
Common Mode input voltage	$V_{IN, CM}$	190	240	300	mV
Differential Input Voltage Swing ^[1]	$V_{IN, DIFF}$		960	1200	mVpk-pk
Transmitter Enable Input Low Voltage ^[2]	V_{IL}	-0.3		0.8	V
Transmitter Enable Input High Voltage ^[2]	V_{IH}	2.0		$V_{DD}+0.3$	V

Notes:

1. To avoid clipping, the differential input amplitude swing must not exceed $4 \times V_{CM}$.
2. The transmitter enable PIN has an internal pull-up resistor.

Transmitter Optical Characteristics

Parameter	Symbol	Min.	Typ.	Max.	Units
Central wavelength	λ_C	635	650	675	nm
Spectral Bandwidth (RMS)	$\Delta\lambda$			17	nm
Average Output Power ^[3]	P	-6.0	-2.1	0.5	dBm
Extinction Ratio ^[3]	ER	8	10		dB
Optical Rise Time (10% - 90%) ^[3, 4]	t_R		2.3	4.0	ns
Optical Fall Time (90% - 10%) ^[3, 4]	t_F		2.6	4.0	ns

Notes:

3. Measured with binary modulation at a data rate of 125 MBd and with typical $V_{IN, CM}$ and $V_{IN, DIFF}$. The output power coupled into the POF is measured with a large area detector at the end of 1 m POF with NA = 0.5, which is ideally coupled to the transmitter.
4. Measured with 62.5 MHz square signal.

Receiver Electrical Characteristics

Parameter	Symbol	Min.	Typ.	Max.	Units
Current Consumption	I_{dd}	12	14	20	mA
Current Consumption – disabled	$I_{dd, Dis}$	0.5	0.7	0.9	mA
Output Common Mode Voltage	$V_{OUT, CM}$	1.18	1.23	1.28	V
Differential Output Voltage Swing ^[5]	$V_{OUT, DIFF}$	180	240	300	mVpk-pk
Single-Ended Output Resistance	$Z_{OUT, SE}$		75		Ω
Differential Output Resistance	$Z_{OUT, DIFF}$		150		Ω
Startup Time from Powersaving	t_{ON}		300		ns
Shutdown Time to Powersaving	t_{OFF}		125		ns
Monitoring Output/Optical Input	$I_{MON/ Pin}$		0.23		A/W
Max. Monitor Voltage ^[6]	$V_{MON, MAX}$			1.3	V
Input voltage for power save mode	$V_{MON, PS-TH}$	1.8			V

Notes:

5. Conditions: Extinction ratio of optical input signal equal to 10 dB, differential load=150 Ω .
6. Monitor current is limited by $V_{MON, MAX}$ /Load resistance

Receiver Optical Characteristics

Parameter	Symbol	Min.	Typ.	Max.	Units
Central wavelength	λ_C	635	650	675	nm

Informative section

Avago cannot guarantee the following parameters and values because they also depend on the performance of the PHY chips. However, you can use them to calculate the 1 Gbps link budget. Furthermore, you can use them to gauge link performance.

Transmitter Optical Characteristics

Parameter	Symbol	Min.	Typ.	Max.	Units
Average Output Power for 1 Gbps ^[1]	P _{OUT 1Gbps}	-5.8	-1.9	0.7	dBm

Unstressed Receiver Optical Characteristics

Parameter	Symbol	Min.	Typ.	Max.	Units
Receiver Input Power for 1 Gbps ^[1, 2]	P _{in 1Gbps Min}	-17.5		3	dBm

Link Performance

Parameter	Symbol	Min.	Typ.	Max.	Units
Link distance ^[1, 3]	l	50			m

Notes:

1. 1 Gbps transmission based on PAM16 modulation. Tested with KDPOF KD1001 PHY-IC.
2. Only optical attenuator is used to degrade the optical input test signal to the receiver.
3. POF parameters: attenuation smaller than 0.19 dB/m, 1 mm core diameter and NA of 0.5. Direct connection between Tx and Rx without inline connector or any additional attenuation.

Mechanical Data - Package Outline

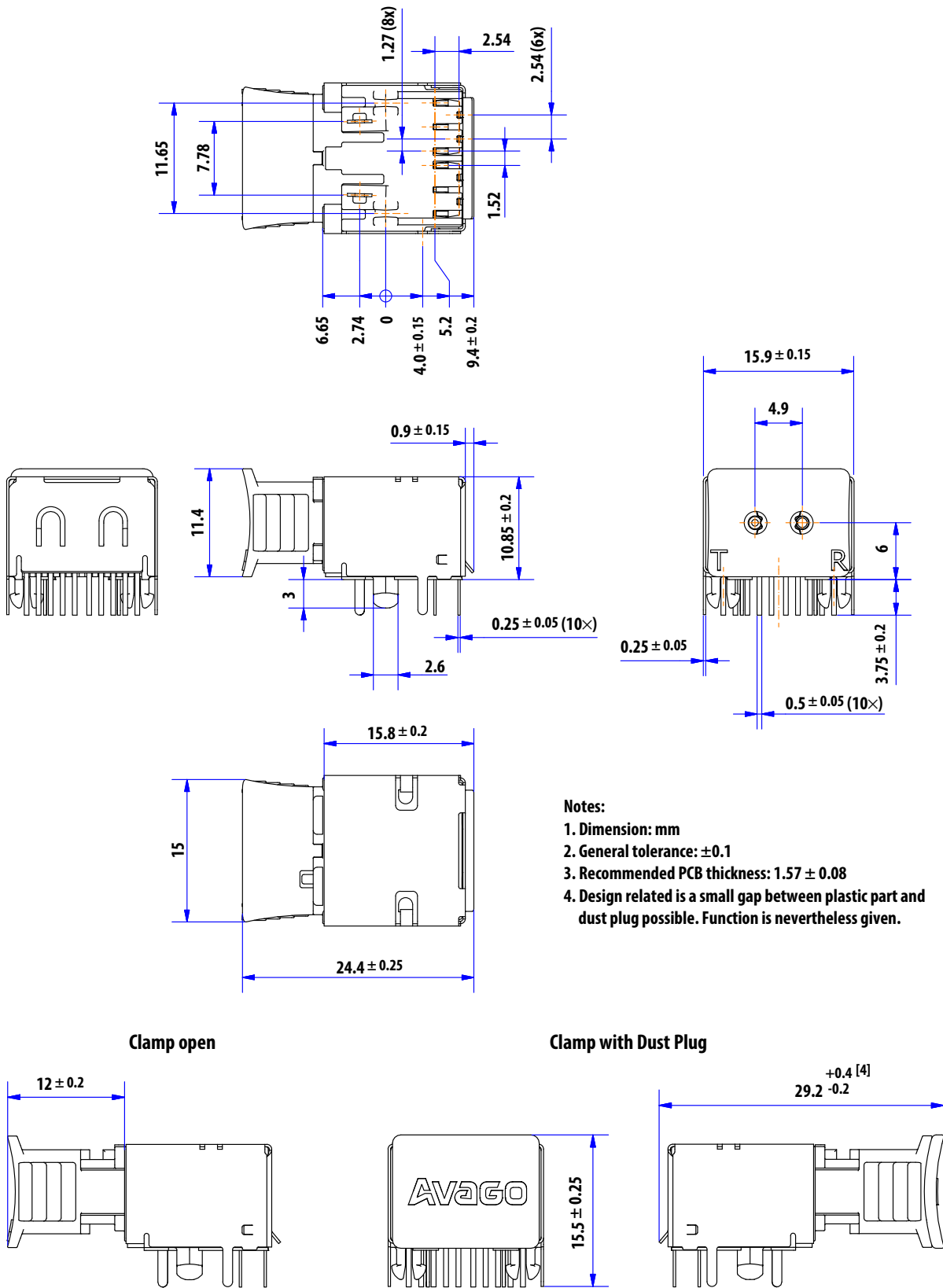
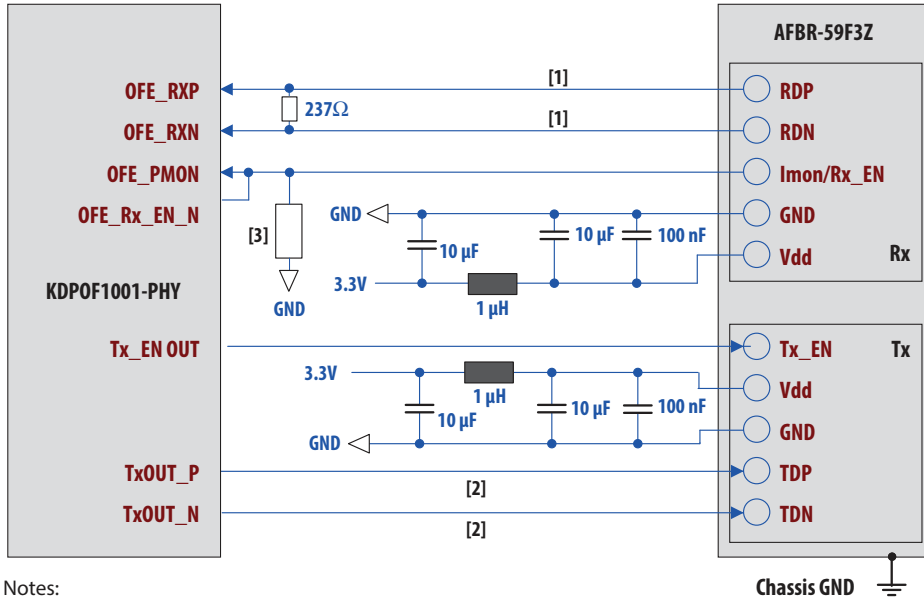

Figure 2. Package Outline Drawing

Application Circuit

The recommended application circuit is shown in Figure 3. It shows the minimum external circuitry at DC-coupling for the connection of the AFBR-59F3Z to the KDPOF 1001-PHY.



Notes:

1. Single-ended output impedance, $Z_{OUT,SE} = 75 \Omega$.
2. Single-ended input impedance, $Z_{IN,SE} = 64 \Omega$.
3. Choose a suitable resistor value such that the output monitor voltage is not saturated. Refer to Figure 4.

Figure 3. Application Circuit with KDPOF KD1001 PHY-IC configuration

Figure 4 depicts the relationship between monitor voltage and POF length with 10 k Ω , 20 k Ω and 47 k Ω .

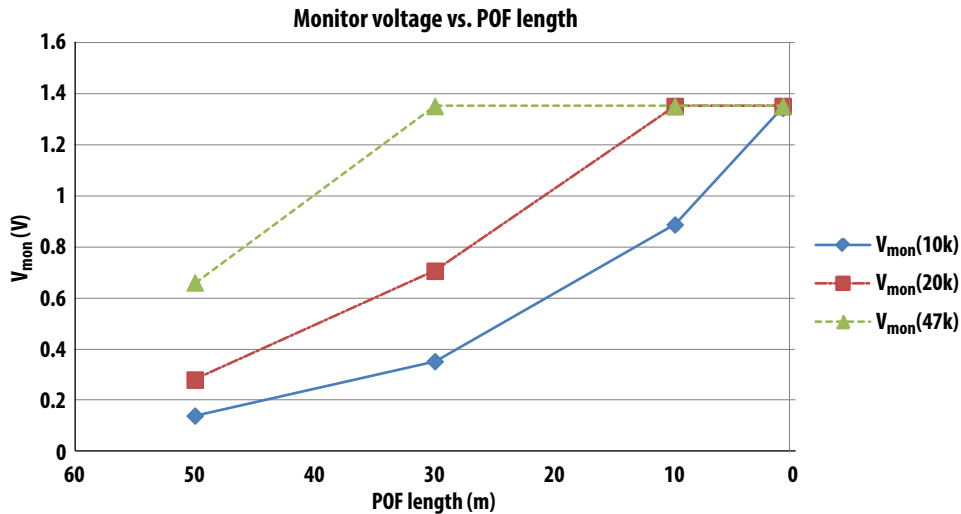
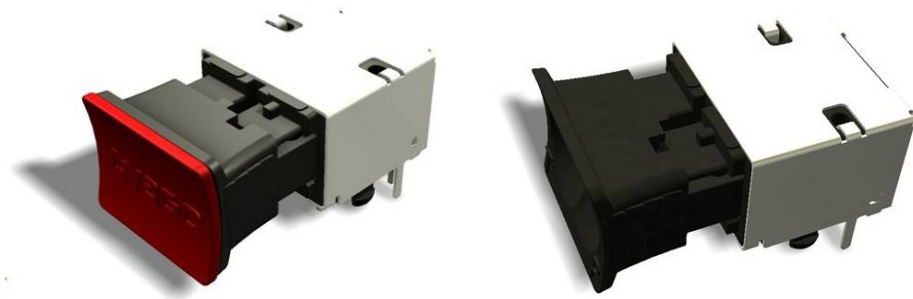

Figure 4. Typical V_{mon} vs. POF length



For product information and a complete list of distributors, please go to our web site: www.avagotech.com

Avago, Avago Technologies, and the A logo are trademarks of Avago Technologies in the United States and other countries.
Data subject to change. Copyright © 2005-2014 Avago Technologies. All rights reserved.
AV02-4655EN - December 17, 2014

Avago
TECHNOLOGIES