

Figure 1. The Physical Photo of ATH10KR8B3404K

MAIN FEATURES

- Glass Encapsulated for Long Term Stability & Reliability
- Small Size: $\phi 0.8\text{mm} \times 1.65\text{mm}$
- High Resistance Accuracy: 1%
- Quick Response Time: 4s
- Wide Temp. Range: -40°C to 200°C
- Leads: Dumet Wires (Copper-Clad FeNi)
- 100% Lead (Pb)-free and RoHS Compliant

APPLICATIONS

The ATH10KR8B3404K thermistor is ideal for temperature sensing in high-precision devices such as laser diodes and optical components that require accurate temperature monitoring. In addition, due to its low cost, it is also suitable for use in automotive electronics, industrial electronics, and home appliances where cost-effective temperature sensing is required.

DESCRIPTION

Figure 1 displays the ATH10KR8B3404K thermistor, which boasts high precision and a glass encapsulation design. In contrast to conventional epoxy-encapsulated thermistors, the ATH10KR8B3404K offers superior long-term stability and a wider temperature range. Moreover, it has a compact size and a quick response time.

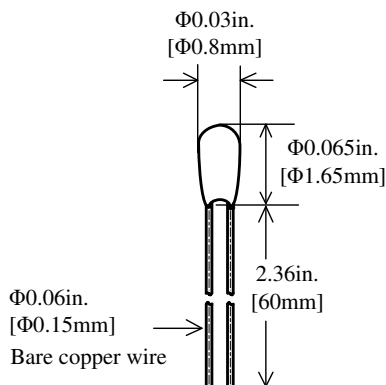

Figure 2. Side View of ATH10KR8B3404K

SPECIFICATIONS

Parameters	Symbol	Value
Nominal Resistance @ 25°C	R ₂₅	10K ± 1%
B Value @ 25°C /50°C	B _{25/50}	3404K ± 1%
B Value @ 25°C /100°C	B _{25/100}	3450K ± 1%
Thermistor Diameter	D _T	0.8 ± 0.15mm
Thermistor Length	L _T	1.65mm
Lead Diameter	D _L	0.15± 0.05mm
Lead Length	L _L	60 ± 5mm
Dissipation Factor	δ _{th}	1.2mW/°C
Insulation Resistance	R _{is}	<10MΩ
Time Constant	τ _c	4s (in still air @5~25°C)

APPLICATION

One common issue encountered when potting the thermistor into a solid object to sense its temperature is the formation of air bubbles within the epoxy between the thermistor bead and the target object. These air bubbles can significantly delay the thermistor's response time. To address this problem, it is recommended to drill a deep counterbore hole and use thermal conductive epoxy to pot the thermistor at the bottom of the hole, as illustrated in Figure 3. This method effectively reduces the formation of air bubbles and enhances the thermistor's overall performance.

To prevent the formation of air bubbles during the potting process, it is recommended to cure the epoxy at the temperature specified by the manufacturer. For optimal results, curing should be conducted in a vacuum environment and/or on top of a vibration platform to eliminate any remaining air pockets. By taking these measures, the potting process can be optimized, resulting in accurate temperature sensing with the shortest possible response time.

The ATH10KR8B3404K thermistor is terminated with leaded bare copper wires. For applications that require

insulated lead wires, we offer insulation tubing. For more information, please click [HERE](#).

The radial glass bead encapsulation NTC thermistor exhibits superior resistance to heat and climatic conditions and have a long lifetime compared to resin-coated thermistors. It is made of bonding lead wire, gold/silver electrodes and qualified ceramic thermistor chip, which makes it keep stable characteristics. It features long-term stability, reliability, wide temperature range and fast thermal response time. Multiple

bead diameters and sensor spec. are available. And they can be easily incorporated into various housing options because of their small size.

Please note that the ATH10KR8B3404K thermistor is not designed for direct immersion in water or other electrically conductive or corrosive liquids, due to the non-isolated nature of its leads. Doing so may result in inaccurate resistance readings, damage to the thermistor's leads, or pose a safety hazard.

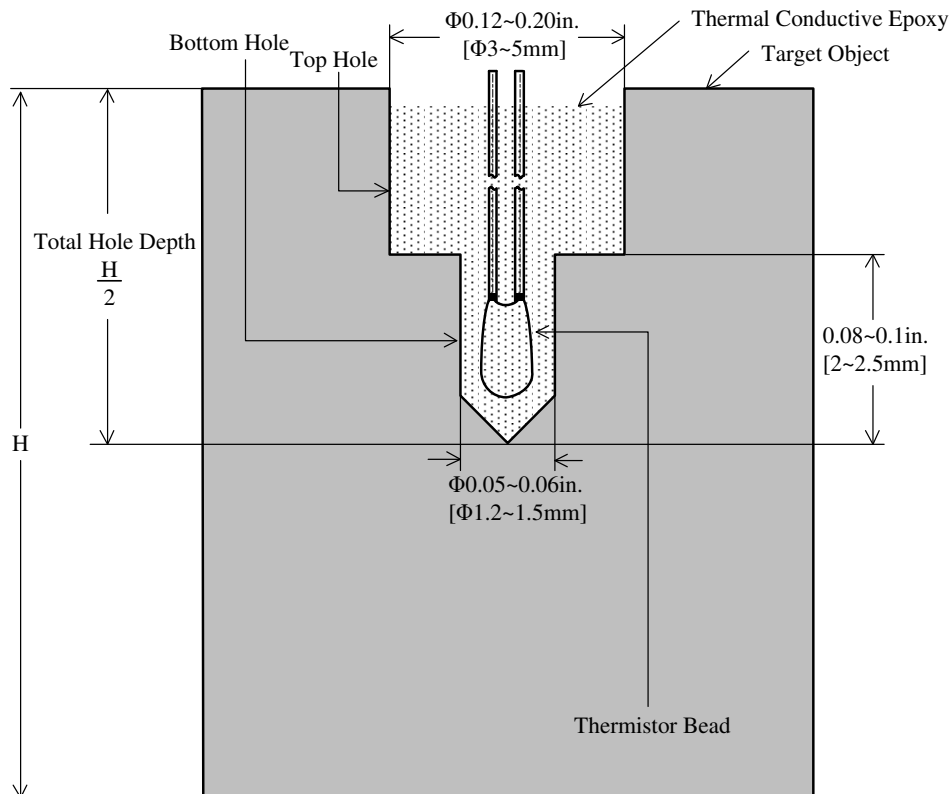

Figure 3. Section View of Recommended Counterbore Hole

PART NUMBER CONVENTION

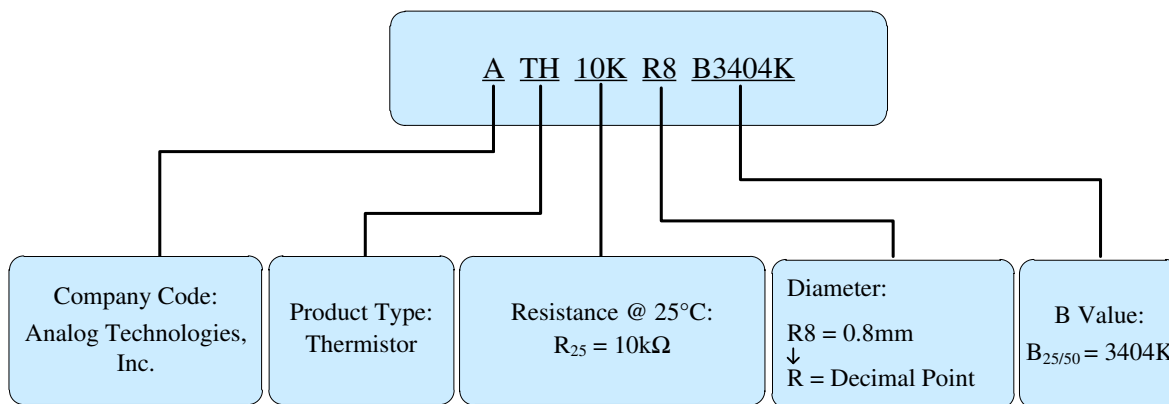

Figure 4. Part Number Convention of ATH10KR8B3404K



RELIABILITY DATA

TEST	TEST CONDITIONS	$\Delta R_{25}/R_{25}$ (typical)	Remarks
Storage in dry heat	Storage at upper category temperature T: 100°C, t: 1000h	$\leq \pm 3\%$	No visible damage
Storage in damp heat, steady state	Temperature of air: $40 \pm 2^\circ\text{C}$ Relative humidity of air: 95% Duration: 1000h	$\leq \pm 3\%$	No visible damage
Storage in cold	Temperature of air: $-20 \pm 2^\circ\text{C}$ Duration: 1000h	$\leq \pm 3\%$	No visible damage
Temperature cycling	Lower test temperature: $-20 \pm 2^\circ\text{C}$ Upper test temperature: $100 - 3^\circ\text{C}$ 1000 cycles Dwell time: 30 min at each temperature	$\leq \pm 3\%$	No visible damage
Long-term stability (empirical value)	Temperature: 70°C t: 10000 h	$\leq \pm 1\%$	No visible damage

RESISTANCE TEMPERATURE CHARACTERISTICS

$B_{25/50} = 3404\text{K}, R_{25} = 10\text{k}\Omega, T_R = 25^\circ\text{C}, \frac{\Delta R_T}{R_T}: \pm 1\%,$						
T (°C)	Resistance (kΩ)			Relative Resistance Variation at a Specific Temperature ($\pm\%$)	Temperature Measurement Error at a Specific Temperature ($\pm^\circ\text{C}$)	Temperature Coefficient ($\%/^\circ\text{C}$)
	Minimum	Nominal	Maximum	$\frac{\Delta R_T}{R_T}$	$\Delta T_N = \frac{\Delta R_N}{R_{N+1} - R_{N-1}}$	$\alpha = \frac{R_{N-1} - R_{N+1}}{2 \times R_N}$
-40	201.119	209.585	218.051	4.04	0.35	5.81
-39	189.880	197.754	205.631	3.98	0.34	5.79
-38	179.358	186.683	194.011	3.92	0.34	5.74
-37	169.500	176.318	183.141	3.87	0.34	5.69
-36	160.260	166.609	172.961	3.81	0.34	5.64
-35	151.596	157.509	163.421	3.75	0.34	5.60
-34	143.466	148.977	154.491	3.70	0.33	5.55
-33	135.835	140.972	146.111	3.64	0.33	5.50
-32	128.668	133.458	138.251	3.59	0.33	5.46
-31	121.934	126.402	130.871	3.53	0.33	5.41
-30	115.603	119.773	123.941	3.48	0.32	5.38
-29	109.630	113.521	117.411	3.43	0.32	5.34
-28	104.011	107.643	111.271	3.37	0.32	5.30
-27	98.722	102.114	105.501	3.32	0.32	5.26
-26	93.741	96.910	100.081	3.27	0.31	5.21



$B_{25/50} = 3404K, R_{25} = 10k\Omega, T_R = 25^\circ C, \frac{\Delta R_T}{R_T}: \pm 1\%$,

T (°C)	Resistance (kΩ)			Relative Resistance Variation at a Specific Temperature (±%)	Temperature Measurement Error at a Specific Temperature (±°C)	Temperature Coefficient (%/°C)
	Minimum	Nominal	Maximum	$\frac{\Delta R_T}{R_T}$	$\Delta T_N = \frac{\Delta R_N}{R_{N+1} - R_{N-1}}$	$\alpha = \frac{R_{N-1} - R_{N+1}}{2 \times R_N}$
-25	89.049	92.010	94.971	3.22	0.31	5.17
-24	84.627	87.394	90.161	3.17	0.31	5.13
-23	80.457	83.044	85.631	3.12	0.31	5.09
-22	76.523	78.943	81.361	3.06	0.30	5.05
-21	72.811	75.074	77.341	3.01	0.30	5.01
-20	69.306	71.423	73.541	2.96	0.30	5.01
-19	65.935	67.914	69.894	2.91	0.29	5.02
-18	62.753	64.603	66.454	2.86	0.29	4.98
-17	59.747	61.478	63.208	2.82	0.28	4.94
-16	56.907	58.526	60.145	2.77	0.28	4.90
-15	54.223	55.737	57.252	2.72	0.28	4.87
-14	51.684	53.101	54.518	2.67	0.28	4.83
-13	49.283	50.609	51.935	2.62	0.27	4.79
-12	47.010	48.251	49.493	2.57	0.27	4.76
-11	44.858	46.020	47.183	2.53	0.27	4.72
-10	42.820	43.908	44.997	2.48	0.26	4.69
-9	40.879	41.898	42.917	2.43	0.26	4.67
-8	39.039	39.993	40.947	2.39	0.26	4.64
-7	37.295	38.188	39.082	2.34	0.25	4.60
-6	35.641	36.478	37.315	2.29	0.25	4.57
-5	34.072	34.856	35.639	2.25	0.25	4.55
-4	32.571	33.305	34.038	2.20	0.24	4.54
-3	31.147	31.833	32.520	2.16	0.24	4.50
-2	29.794	30.437	31.080	2.11	0.24	4.47
-1	28.510	29.112	29.714	2.07	0.23	4.44
0	27.290	27.853	28.417	2.02	0.23	4.41
1	26.125	26.653	27.181	1.98	0.23	4.39
2	25.019	25.513	26.007	1.94	0.22	4.36
3	23.967	24.429	24.891	1.89	0.22	4.33
4	22.966	23.399	23.831	1.85	0.22	4.30
5	22.013	22.419	22.824	1.81	0.21	4.30



$B_{25/50} = 3404K, R_{25} = 10k\Omega, T_R = 25^\circ C, \frac{\Delta R_T}{R_T}: \pm 1\%$,

T (°C)	Resistance (kΩ)			Relative Resistance Variation at a Specific Temperature (±%)	Temperature Measurement Error at a Specific Temperature (±°C)	Temperature Coefficient (%/°C)
	Minimum	Nominal	Maximum	$\frac{\Delta R_T}{R_T}$	$\Delta T_N = \frac{\Delta R_N}{R_{N+1} - R_{N-1}}$	$\alpha = \frac{R_{N-1} - R_{N+1}}{2 \times R_N}$
6	21.093	21.472	21.851	1.76	0.21	4.30
7	20.218	20.572	20.926	1.72	0.20	4.27
8	19.384	19.715	20.046	1.68	0.20	4.24
9	18.591	18.900	19.209	1.64	0.19	4.21
10	17.835	18.124	18.413	1.59	0.19	4.16
11	17.123	17.393	17.663	1.55	0.19	4.11
12	16.443	16.696	16.948	1.51	0.19	4.08
13	15.795	16.031	16.267	1.47	0.18	4.05
14	15.177	15.398	15.618	1.43	0.18	4.02
15	14.587	14.793	14.999	1.39	0.17	4.02
16	14.017	14.209	14.401	1.35	0.17	4.02
17	13.473	13.651	13.830	1.31	0.16	3.99
18	12.953	13.120	13.286	1.27	0.16	3.96
19	12.456	12.612	12.767	1.23	0.16	3.94
20	11.982	12.127	12.272	1.19	0.15	3.92
21	11.528	11.662	11.797	1.15	0.15	3.90
22	11.093	11.218	11.343	1.11	0.14	3.87
23	10.678	10.794	10.910	1.08	0.14	3.84
24	10.281	10.389	10.496	1.04	0.14	3.82
25	9.901	10.001	10.101	1.00	0.13	3.78
26	9.533	9.633	9.733	1.04	0.14	3.74
27	9.181	9.281	9.380	1.07	0.14	3.72
28	8.844	8.943	9.043	1.11	0.15	3.69
29	8.522	8.621	8.720	1.15	0.16	3.66
30	8.213	8.312	8.410	1.19	0.16	3.68
31	7.912	8.010	8.108	1.22	0.17	3.69
32	7.624	7.721	7.818	1.26	0.17	3.67
33	7.347	7.444	7.540	1.30	0.18	3.64
34	7.083	7.179	7.274	1.33	0.18	3.61
35	6.830	6.925	7.019	1.37	0.19	3.58
36	6.590	6.683	6.777	1.40	0.20	3.54



$B_{25/50} = 3404K, R_{25} = 10k\Omega, T_R = 25^\circ C, \frac{\Delta R_T}{R_T}: \pm 1\%$,

T (°C)	Resistance (kΩ)			Relative Resistance Variation at a Specific Temperature (±%)	Temperature Measurement Error at a Specific Temperature (±°C)	Temperature Coefficient (%/°C)
	Minimum	Nominal	Maximum	$\frac{\Delta R_T}{R_T}$	$\Delta T_N = \frac{\Delta R_N}{R_{N+1} - R_{N-1}}$	$\alpha = \frac{R_{N-1} - R_{N+1}}{2 \times R_N}$
37	6.359	6.452	6.545	1.44	0.21	3.51
38	6.138	6.230	6.322	1.47	0.21	3.49
39	5.926	6.017	6.108	1.51	0.22	3.47
40	5.723	5.813	5.902	1.54	0.22	3.47
41	5.525	5.614	5.702	1.58	0.23	3.47
42	5.335	5.423	5.510	1.61	0.23	3.46
43	5.153	5.239	5.326	1.65	0.24	3.44
44	4.978	5.063	5.149	1.68	0.25	3.41
45	4.811	4.894	4.978	1.71	0.25	3.40
46	4.647	4.730	4.813	1.75	0.26	3.40
47	4.491	4.572	4.654	1.78	0.26	3.38
48	4.340	4.421	4.501	1.82	0.27	3.36
49	4.196	4.275	4.354	1.85	0.28	3.35
50	4.057	4.135	4.213	1.88	0.28	3.31
51	3.925	4.001	4.078	1.92	0.29	3.27
52	3.797	3.873	3.948	1.95	0.30	3.25
53	3.675	3.749	3.823	1.98	0.30	3.24
54	3.557	3.630	3.703	2.01	0.31	3.22
55	3.444	3.515	3.587	2.05	0.32	3.20
56	3.334	3.405	3.476	2.08	0.33	3.17
57	3.229	3.299	3.368	2.11	0.33	3.15
58	3.128	3.197	3.265	2.14	0.34	3.14
59	3.031	3.098	3.165	2.17	0.35	3.13
60	2.937	3.003	3.069	2.20	0.35	3.10
61	2.847	2.912	2.977	2.23	0.36	3.07
62	2.761	2.824	2.888	2.26	0.37	3.05
63	2.677	2.740	2.803	2.29	0.38	3.01
64	2.597	2.659	2.720	2.33	0.38	3.01
65	2.519	2.580	2.641	2.36	0.39	3.02
66	2.444	2.503	2.563	2.39	0.39	3.02
67	2.371	2.429	2.488	2.42	0.40	2.98



$B_{25/50} = 3404K, R_{25} = 10k\Omega, T_R = 25^\circ C, \frac{\Delta R_T}{R_T}: \pm 1\%$,

T (°C)	Resistance (kΩ)			Relative Resistance Variation at a Specific Temperature (±%)	Temperature Measurement Error at a Specific Temperature (±°C)	Temperature Coefficient (%/°C)
	Minimum	Nominal	Maximum	$\frac{\Delta R_T}{R_T}$	$\Delta T_N = \frac{\Delta R_N}{R_{N+1} - R_{N-1}}$	$\alpha = \frac{R_{N-1} - R_{N+1}}{2 \times R_N}$
68	2.300	2.358	2.415	2.45	0.41	2.97
69	2.232	2.289	2.345	2.47	0.42	2.97
70	2.167	2.222	2.278	2.50	0.43	2.93
71	2.105	2.159	2.214	2.53	0.44	2.87
72	2.045	2.098	2.152	2.56	0.45	2.84
73	1.987	2.040	2.092	2.59	0.46	2.82
74	1.931	1.983	2.035	2.62	0.46	2.82
75	1.877	1.928	1.979	2.65	0.46	2.88
76	1.822	1.872	1.922	2.68	0.45	2.94
77	1.769	1.818	1.867	2.70	0.46	2.92
78	1.718	1.766	1.815	2.73	0.48	2.89
79	1.669	1.716	1.763	2.76	0.48	2.86
80	1.621	1.668	1.714	2.79	0.49	2.85
81	1.575	1.621	1.667	2.82	0.50	2.84
82	1.531	1.576	1.621	2.85	0.51	2.82
83	1.488	1.532	1.576	2.88	0.51	2.81
84	1.447	1.490	1.534	2.90	0.54	2.68
85	1.410	1.452	1.495	2.94	0.54	2.72
86	1.369	1.411	1.453	2.96	0.53	2.80
87	1.332	1.373	1.414	2.99	0.55	2.69
88	1.297	1.337	1.377	3.01	0.56	2.66
89	1.262	1.302	1.341	3.04	0.56	2.69
90	1.229	1.267	1.306	3.07	0.57	2.68
91	1.196	1.234	1.272	3.09	0.58	2.67
92	1.164	1.201	1.238	3.12	0.57	2.71
93	1.133	1.169	1.206	3.15	0.59	2.65
94	1.103	1.139	1.175	3.17	0.60	2.63
95	1.074	1.109	1.144	3.20	0.60	2.61
96	1.046	1.081	1.116	3.23	0.64	2.54
97	1.019	1.054	1.088	3.25	0.64	2.56
98	0.994	1.027	1.061	3.28	0.64	2.53



$B_{25/50} = 3404K, R_{25} = 10k\Omega, T_R = 25^\circ C, \frac{\Delta R_T}{R_T}: \pm 1\%$,

T (°C)	Resistance (kΩ)			Relative Resistance Variation at a Specific Temperature (±%)	Temperature Measurement Error at a Specific Temperature (±°C)	Temperature Coefficient (%/°C)
	Minimum	Nominal	Maximum	$\frac{\Delta R_T}{R_T}$	$\Delta T_N = \frac{\Delta R_N}{R_{N+1} - R_{N-1}}$	$\alpha = \frac{R_{N-1} - R_{N+1}}{2 \times R_N}$
99	0.969	1.002	1.035	3.30	0.66	2.50
100	0.944	0.977	1.009	3.33	0.65	2.56
101	0.920	0.952	0.984	3.35	0.65	2.57
102	0.897	0.928	0.959	3.38	0.66	2.53
103	0.874	0.905	0.936	3.40	0.67	2.54
104	0.852	0.882	0.912	3.43	0.67	2.55
105	0.831	0.860	0.890	3.45	0.67	2.56
106	0.809	0.838	0.867	3.48	0.67	2.57
107	0.788	0.817	0.845	3.51	0.68	2.57
108	0.768	0.796	0.824	3.53	0.67	2.64
109	0.748	0.775	0.803	3.56	0.69	2.58
110	0.729	0.756	0.783	3.58	0.73	2.45
111	0.712	0.738	0.765	3.61	0.76	2.37
112	0.695	0.721	0.747	3.63	0.76	2.36
113	0.679	0.704	0.730	3.65	0.77	2.34
114	0.663	0.688	0.713	3.68	0.78	2.33
115	0.648	0.672	0.697	3.70	0.79	2.31
116	0.633	0.657	0.682	3.72	0.82	2.28
117	0.618	0.642	0.666	3.75	0.83	2.26
118	0.604	0.628	0.651	3.77	0.84	2.23
119	0.590	0.614	0.637	3.79	0.84	2.28
120	0.577	0.600	0.623	3.81	0.82	2.33
121	0.563	0.586	0.608	3.84	0.80	2.39
122	0.550	0.572	0.594	3.86	0.79	2.45
123	0.537	0.558	0.580	3.89	0.80	2.42
124	0.524	0.545	0.566	3.91	0.81	2.39
125	0.512	0.532	0.553	3.93	0.82	2.35
126	0.499	0.520	0.541	3.96	0.88	2.31
127	0.488	0.508	0.528	3.98	0.83	2.36
128	0.476	0.496	0.516	4.00	0.87	2.32
129	0.465	0.485	0.504	4.03	0.89	2.27



$B_{25/50} = 3404K, R_{25} = 10k\Omega, T_R = 25^\circ C, \frac{\Delta R_T}{R_T}: \pm 1\%$,

T (°C)	Resistance (kΩ)			Relative Resistance Variation at a Specific Temperature (±%)	Temperature Measurement Error at a Specific Temperature (±°C)	Temperature Coefficient (%/°C)
	Minimum	Nominal	Maximum	$\frac{\Delta R_T}{R_T}$	$\Delta T_N = \frac{\Delta R_N}{R_{N+1} - R_{N-1}}$	$\alpha = \frac{R_{N-1} - R_{N+1}}{2 \times R_N}$
130	0.455	0.474	0.493	4.05	0.90	2.22
131	0.445	0.464	0.483	4.07	0.95	2.16
132	0.436	0.454	0.473	4.09	0.97	2.09
133	0.427	0.445	0.463	4.11	1.00	2.02
134	0.418	0.436	0.454	4.13	1.00	2.06
135	0.409	0.427	0.444	4.16	0.97	2.11
136	0.401	0.418	0.435	4.18	0.94	2.15
137	0.392	0.409	0.427	4.20	1.03	2.08
138	0.384	0.401	0.418	4.22	1.06	2.00
139	0.376	0.393	0.410	4.24	1.06	2.04
140	0.369	0.385	0.402	4.26	1.03	2.08
141	0.361	0.377	0.393	4.28	1.00	2.12
142	0.353	0.369	0.385	4.30	1.00	2.17
143	0.346	0.361	0.377	4.32	1.03	2.08
144	0.339	0.354	0.369	4.34	1.07	1.98
145	0.332	0.347	0.362	4.36	1.07	2.02
146	0.325	0.340	0.354	4.38	1.04	2.06
147	0.318	0.333	0.347	4.40	1.04	2.10
148	0.311	0.326	0.340	4.43	1.04	2.15
149	0.305	0.319	0.333	4.45	1.08	2.04
150	0.299	0.313	0.327	4.47	1.08	2.08
151	0.293	0.306	0.320	4.49	1.04	2.12
152	0.287	0.300	0.314	4.51	1.13	2.00
153	0.281	0.294	0.307	4.53	1.08	2.04
154	0.275	0.288	0.301	4.55	1.08	2.08
155	0.269	0.282	0.295	4.57	1.08	2.13
156	0.264	0.276	0.289	4.59	1.14	1.99
157	0.258	0.271	0.283	4.61	1.14	2.03
158	0.253	0.265	0.278	4.63	1.14	2.08
159	0.248	0.260	0.272	4.65	1.20	1.92
160	0.243	0.255	0.267	4.67	1.20	1.96



$B_{25/50} = 3404K, R_{25} = 10k\Omega, T_R = 25^\circ C, \frac{\Delta R_T}{R_T}: \pm 1\%$,

T (°C)	Resistance (kΩ)			Relative Resistance Variation at a Specific Temperature (±%)	Temperature Measurement Error at a Specific Temperature (±°C)	Temperature Coefficient (%/°C)
	Minimum	Nominal	Maximum	$\frac{\Delta R_T}{R_T}$	$\Delta T_N = \frac{\Delta R_N}{R_{N+1} - R_{N-1}}$	$\alpha = \frac{R_{N-1} - R_{N+1}}{2 \times R_N}$
161	0.238	0.250	0.262	4.69	1.20	2.00
162	0.234	0.245	0.257	4.71	1.15	2.04
163	0.229	0.240	0.252	4.73	1.28	1.88
164	0.224	0.236	0.247	4.75	1.28	1.91
165	0.220	0.231	0.242	4.77	1.22	1.95
166	0.216	0.227	0.237	4.79	1.17	1.98
167	0.212	0.222	0.233	4.81	1.17	2.03
168	0.207	0.218	0.228	4.83	1.31	1.83
169	0.203	0.214	0.224	4.85	1.31	1.87
170	0.199	0.210	0.220	4.87	1.31	1.90
171	0.196	0.206	0.216	4.89	1.25	1.94
172	0.192	0.202	0.212	4.91	1.25	1.98
173	0.188	0.198	0.208	4.92	1.25	2.02
174	0.185	0.194	0.204	4.94	1.36	1.80
175	0.181	0.191	0.200	4.96	1.36	1.83
176	0.178	0.187	0.196	4.98	1.29	1.87
177	0.175	0.184	0.193	5.00	1.29	1.90
178	0.171	0.180	0.189	5.02	1.29	1.94
179	0.168	0.177	0.186	5.04	1.50	1.69
180	0.165	0.174	0.183	5.06	1.50	1.72
181	0.162	0.171	0.179	5.07	1.21	2.05
182	0.159	0.167	0.176	5.09	1.21	2.10
183	0.156	0.164	0.173	5.11	1.42	1.83
184	0.153	0.161	0.170	5.13	1.42	1.86
185	0.150	0.158	0.167	5.15	1.70	1.58
186	0.148	0.156	0.164	5.17	1.60	1.60
187	0.145	0.153	0.161	5.18	1.33	1.96
188	0.142	0.150	0.158	5.20	1.33	2.00
189	0.140	0.147	0.155	5.22	1.50	1.70
190	0.137	0.145	0.152	5.24	1.50	1.72
191	0.135	0.142	0.150	5.26	1.50	1.76



$B_{25/50} = 3404K, R_{25} = 10k\Omega, T_R = 25^\circ C, \frac{\Delta R_T}{R_T}: \pm 1\%$						
T (°C)	Resistance (kΩ)			Relative Resistance Variation at a Specific Temperature (±%)	Temperature Measurement Error at a Specific Temperature (±°C)	Temperature Coefficient (%/°C)
	Minimum	Nominal	Maximum	$\frac{\Delta R_T}{R_T}$	$\Delta T_N = \frac{\Delta R_N}{R_{N+1} - R_{N-1}}$	$\alpha = \frac{R_{N-1} - R_{N+1}}{2 \times R_N}$
192	0.132	0.140	0.147	5.28	1.50	1.79
193	0.130	0.137	0.144	5.29	1.40	1.82
194	0.128	0.135	0.142	5.31	1.40	1.85
195	0.125	0.132	0.139	5.33	1.40	1.89
196	0.123	0.130	0.137	5.35	1.75	1.54
197	0.121	0.128	0.135	5.36	1.75	1.56
198	0.119	0.126	0.132	5.38	1.63	1.59
199	0.117	0.124	0.130	5.40	1.30	2.02
200	0.115	0.121	0.128	5.42	1.30	1.80

To ensure optimal performance and reliability, it is recommended to follow proper storage procedures for the ATH10KR8B3404K thermistor. Here are some guidelines:

1. Store the thermistors only in their original packaging and do not open the package before storage.
2. The recommended storage temperature is between $-25^\circ C$ to $+45^\circ C$, with a relative humidity of less than 75% on average and a maximum of 95%. Dew precipitation is not allowed.
3. Do not expose the thermistors to heat or direct sunlight during storage as this may cause deformation of the packing material or sticking of the thermistors, leading to difficulties during mounting.
4. Avoid contamination of the thermistor’s surface during storage, handling, and processing.
5. Do not store the thermistor in harmful environments containing corrosive gases like SOx, Cl, etc.
6. After opening the factory seals, such as polyvinyl-sealed packages, it is recommended to use the thermistors as soon as possible.
7. For optimal soldering performance, it is recommended to solder the thermistors within 12 months for SMDs and 24 months for leaded components after shipment from the manufacturer, ATI.

When handling NTC thermistors, it is important to prevent them from being dropped, as this could cause chip-offs and damage to the components. To avoid any damage, components should not be touched with bare hands, and gloves are recommended. It is also important to prevent any contamination of the thermistor surface during handling to ensure accurate readings.

When soldering the ATH10KR8B3404K thermistor, it is important to use a resin-type or non-activated flux. Insufficient preheating can cause ceramic cracks, so proper preheating is recommended. Rapid cooling by dipping in solvent is not recommended. It is also recommended to completely remove any flux residue after soldering to prevent contamination or damage to the thermistor.

ORDERING INFORMATION

Part Number	Buy Now
ATH10KR8B3404K	



NOTICE

1. It is important to carefully read and follow the warnings, cautions, and product-specific notes provided with electronic components. These instructions are designed to ensure the safe and proper use of the component and to prevent damage to the component or surrounding equipment. Failure to follow these instructions could result in malfunction or failure of the component, damage to surrounding equipment, or even injury or harm to individuals. Always take the necessary precautions and seek professional assistance if unsure about proper use or handling of electronic components.
2. Please note that the products and specifications described in this publication are subject to change without prior notice as we continuously improve our products. Therefore, we recommend checking the product descriptions and specifications before placing an order to ensure that they are still applicable. We also reserve the right to discontinue the production and delivery of certain products, which means that not all products named in this publication may always be available.
3. This means that while ATI may provide information about the typical requirements and applications of their products, they cannot guarantee that their products will be suitable for all customer applications. It is the responsibility of the customer to evaluate whether an ATI product with the specified properties is appropriate for their particular application.
4. ATI warrants its products to perform according to specifications for one year from the date of sale, except when damaged due to excessive abuse. If a product fails to meet specifications within one year of the sale, it can be exchanged free of charge.
5. ATI reserves the right to make changes or discontinue products or services without notice. Customers are advised to obtain the latest information before placing orders.
6. All products are sold subject to terms and conditions of sale, including those pertaining to warranty, patent infringement, and limitation of liability. Customers are responsible for their applications using ATI products, and ATI assumes no liability for applications assistance or customer product design.
7. ATI does not grant any license, either express or implied, under any patent right, copyright, mask work right, or other intellectual property right of ATI.
8. ATI's publication of information regarding third-party products or services does not constitute approval, warranty, or endorsement.
9. ATI retains ownership of all rights for special technologies, techniques, and designs for its products and projects, as well as any modifications, improvements, and inventions made by ATI.
10. Please note that despite operating the passive electronic components as specified, malfunctions or failures before the end of their usual service life may still occur in individual cases due to the current state of the art. Therefore, in customer applications that require a high level of operational safety, especially those in which the malfunction or failure of a passive electronic component could pose a threat to human life or health (such as in accident prevention or life-saving systems), it is essential to ensure through suitable design of the customer application or other measures taken by the customer (such as the installation of protective circuitry or redundancy) that no injury or damage is sustained by third parties in the event of a passive electronic component malfunction or failure.